

Bourdon Tube Pressure Gauge Compressed Specialty Gas Gauge Type 131.15 - Stainless Steel Wetted Parts Type 161.15 - Monel Wetted Parts

WIKA Datasheet 1X1.15

Applications

- Compressed specialty gas regulators
- Applications requiring stainless steel or Monel wetted parts
- Suitable for all media that will not obstruct the pressure system or attack 316SS or Monel parts

Special features

- 316L or Monel wetted parts
- Twist-lock polycarbonate window
- Ranges to 10,000 psi

Standard Features

Design

ASME B40.100

Sizes

2" & 2½" (53 & 68 mm)

Accuracy class

± 3/2/3% of span (ASME B40.100 Grade B)

Ranges

Vacuum / Compound to 200 psi
Pressure from 15 psi to 10,000 psi
or other equivalent units of pressure or vacuum

Working pressure

Steady: 3/4 of full scale value
Fluctuating: 2/3 of full scale value
Short time: full scale value

Operating temperature

Ambient: -40°F to 140°F (-40°C to 60°C)
Media: 140°F (+60°C) maximum

Temperature error

Additional error when temperature changes from reference temperature of 68°F (20°C) ±0.4% for every 18°F (10°C) rising or falling. Percentage of span.



Bourdon Tube Pressure Gauge Type 131.15

Pressure connection

Material: 316L SS - Type 131.15
Monel - Type 161.15
1/8" or 1/4" NPT lower mount (LM)

Bourdon Tube

Material: 316L SS - Type 131.15
Monel - Type 161.15
15 psi to 600 psi: C-type
800 psi to 6,000 psi: helical

Movement

Copper alloy

Dial

White aluminum with stop pin and black lettering
"USE NO OIL" in red

Pointer

Black aluminum

Case

Chrome-plated steel

Window

Twist-lock clear polycarbonate

Optional Extras

- SS or Monel restrictor
- Painted steel case
- Polished brass case
- Nickel-plated socket
- Cleaned for oxygen service
- Stainless steel case (2" only)
- Helium leak test
- Special threaded connection
- Custom dial layout
- Other pressure scales available:
bar, kPa, MPa, kg/cm² and dual scales

Dimensions

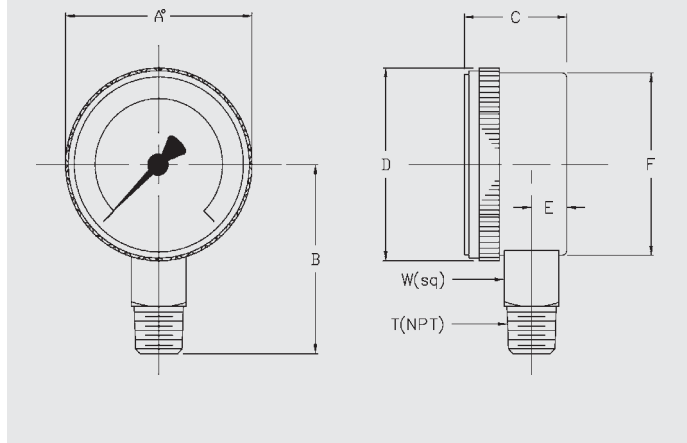

Size		A	B	C ¹	D	E ¹	F	T	W	Weight
2"	mm	53	54	29	58	10.5	50.8	-	14	
	in	2.0	2.12	1.14	2.28	0.42	2.0	1/4"	0.55	0.24 lb
2.5"	mm	68	60	31	72.4	12	67.6	-	14	
	in	2.5	2.36	1.22	2.85	0.47	2.66	1/4"	0.55	0.33 lb

¹ For 2½" painted steel case, C dimension changes to 1.14" (29 mm), and E dimension changes to 0.35" (9 mm)

Ordering information

Pressure gauge model / Nominal size / Scale range / Size of connection / Optional extras required
 Specifications and dimensions given in this leaflet represent the state of engineering at the time of printing.
 Modifications may take place and materials specified may be replaced by others without prior notice.



WIKAL Instrument Corporation
 1000 Wiegand Boulevard
 Lawrenceville, GA 30045
 Tel (770) 513-8200 Toll-free 1-888-WIKA-USA
 Fax (770) 338-5118
 E-Mail info@wika.com
 www.wika.com