

Remove Dirt, Water and Acids From Oils and Fuels

FEATURES

- No tools required for changeout
- 150 psi design pressure
- Epoxy coated interior and exterior
- Positive O-ring closure

CARTRIDGE SELECTION

Water and Dirt Removal – AC-718 Series *Aquacon*® Cartridges remove both water and dirt from all oils and fuels. SD-718 *Superdri*® Cartridges remove dissolved water from insulating oils.

Acid Removal – LA-71801B Cartridges contain the most effective form of fuller's earth available. LB-71801 Cartridges contain activated alumina. Field proven in vacuum pump oil applications.

Solids Removal – FO-718PL Series high surface area pleated cartridges are the most cost effective for particulate contaminant removal. FOS-618/718PL Series all synthetic media cartridges are also available for particle removal. For removing amorphous, soft contaminants, FO-618FGA Series Cartridges with fiberglass depth media are often the most cost effective.

APPLICATIONS

- | | | |
|------------------|-----------------|-------------------|
| • Insulating Oil | • Kerosene | • Turbine Oil |
| • Hydraulic Oil | • Gasoline | • Lube Oil |
| • Cutting Oil | • Synthetic Oil | • Water/Glycol |
| • Diesel Fuel | • Biodiesel | • Vacuum Pump Oil |



DIMENSIONS

Housing	VF81C	VF82C	VF82B
Inlet/Outlet	2" NPT	2" NPT	2" NPT
A	31.5" (80 cm)	48.5" (123.1 cm)	44" (111.8 cm)
B	8.6" (21.9 cm)	8.6" (21.9 cm)	8.6" (21.9 cm)
C	3" (7.6 cm)	3" (7.6 cm)	7.5" (19 cm)
D	3" (7.6 cm)	3" (7.6 cm)	2.5" (6.3 cm)
Volume	6 gal (22.7 l)	10 gal (37.9 l)	9 gal (34 l)
Vessel Weight – Empty	90 lbs (40.8 kg)	118 lbs (53.5 kg)	86 lbs (39 kg)
Shipping Weight	110 lbs (49.9 kg)	138 lbs (62.6 kg)	106 lbs (48 kg)
Number of Standard Cartridges	1	2	2
Lid Gasket – Buna-N	G-1045	G-1045	G-1045

VF81C and VF82C

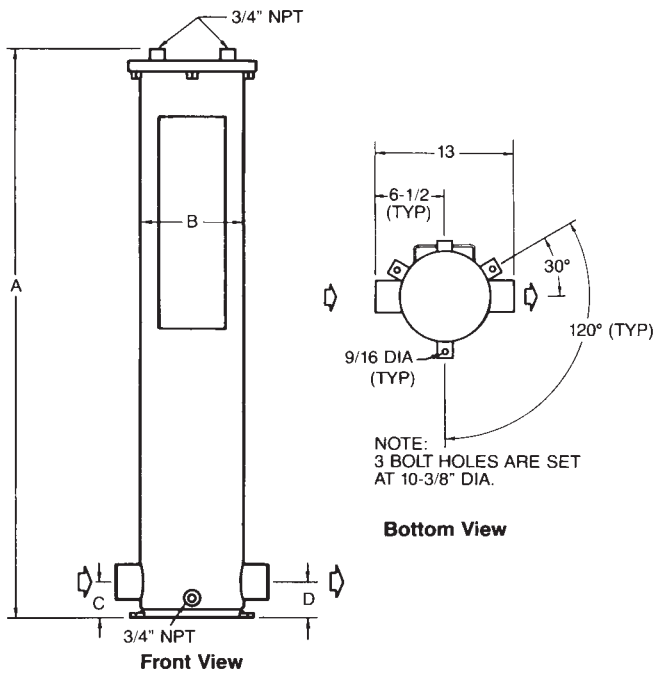

VF82B

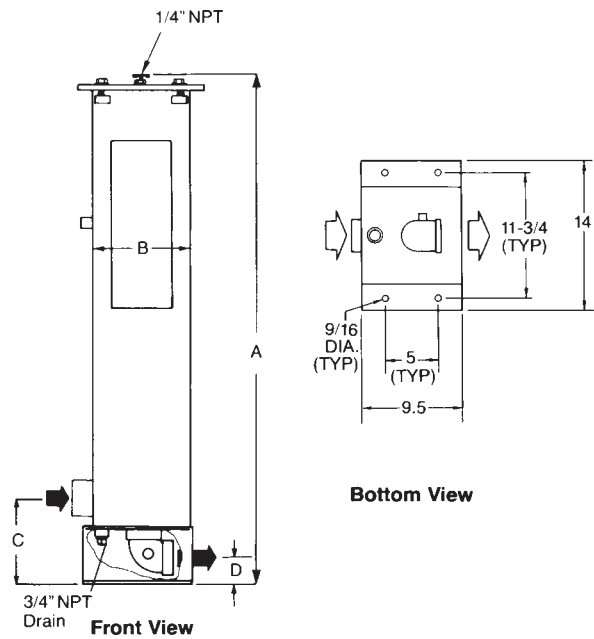

ORDERING INFORMATION (Specify)

Housing (Add -EPX for Internal Epoxy Coating)	VF81C150 (ASME Code Design)	Recommended Spares	6 Spare Filter Cartridges	
	VF82C150 (ASME Code Design)		1 Lid Gasket	
	VF82B150 (Non-ASME Code Design)		Accessories	#120-A Direct Reading Gammon Gauge, piston type
	ASME Code Stamp – Specify if Required			#120-F Differential Pressure Gauge
	G-1045A Viton Lid Gasket			
Cartridge Types (not included with housing)	FO-718PL Series Pleated Synthetic Media			
	FOS-618PL Series Pleated Media			
	FO-618FGA Series Fiberglass Depth Media			
	LA-61801B Fuller's Earth Media			
	AC-718 Series Aquacon [®] Free Water-Absorbing Media			
	SD-718 Superdri [®] Dissolved Water Removal Media			



Velcon products are sold and serviced by a world-wide representative network. To order, contact Headquarters or your **LOCAL REPRESENTATIVE**:

COMPANY HEADQUARTERS:
 Velcon Filters, LLC
 1210 Garden of the Gods Road
 Colorado Springs, CO 80907-3410
 Phone: 1.800.531.0180 / 1.719.531.5855
 Fax: 719.531.5690
 e-mail: vfsales@velcon.com
 www.velcon.com

MANUFACTURING PLANTS LOCATED AT:
 Colorado Springs, Colorado
 Sylacauga, Alabama
 Henryetta, Oklahoma

OFFICES & AFFILIATES IN:
 Canada, Germany, Singapore & Spain



Liquid Filtration and Separation Specialists

Due to Velcon Filters' continuing product improvement, drawings, specifications and pictures are subject to change without notice.

Buy: www.ValinOnline.com | Phone 844-385-3099 | Email: CustomerService@valin.com

DIMENSIONS

Housing	VF166C	VF2012C
Inlet/Outlet	3" NPT	4" NPT
A	47 1/4" (120 cm)	52 3/4" (134 cm)
B	16" (40.6 cm)	20" (50.8 cm)
C	11" (27.9 cm)	14" (35.6 cm)
D	4" (10.2cm)	5" (12.7 cm)
E	13" (33 cm)	16" (40.6 cm)
F	20" (50.8 cm)	25" (63.5 cm)
Volume	38 gal (144 L)	65 gal (246 L)
Vessel Weight – empty	355 lbs (140 kg)	592 lbs (270 kg)
Shipping Weight	405 lbs (160 kg)	642 lbs (292 kg)
Number of Standard Cartridges	6	12
Lid Gasket – Buna-N	G-2033	G-2027

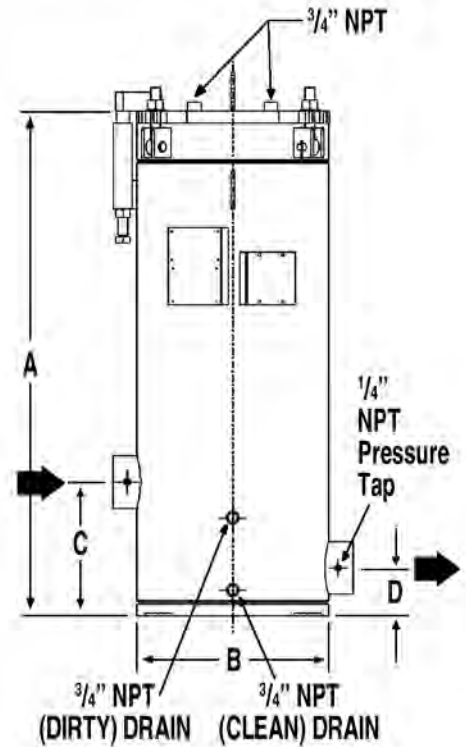

ORDERING INFORMATION (Specify)

Housing	VF166C150
	VF2012C150
	ASME Code Stamp – Specify if Required
Cartridge Types (not included with housing)	FO-718PL Series Pleated Media
	FO-618 FGA Series Fiberglass Depth Media
	FOS-618/718 Series Synthetic Media Pleated Cartridges
	LA-61801B Fullers Earth Media
	AC-718 Series Aquacon ® Water Absorbing Media Cartridge
	SD-718 Series Superdri ® dissolved water removal cartridges
Recommended Spares	1 Set of Spare Filter Cartridges
	1 Lid Gasket
Accessories	#120-H Differential Pressure Gauge
	VF166CI50EPX Internal Epoxy Coating
	G-2033A (VF166C150) Viton Lid Gaskets
	G-2027A (VF2012C150)

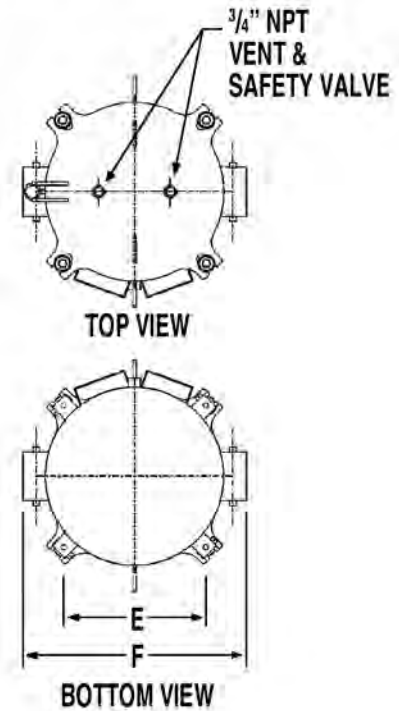

Obtain Certified Drawing
before pouring slab



Velcon products are sold and serviced by a world-wide representative network. To order, contact Headquarters or your LOCAL REPRESENTATIVE:

COMPANY HEADQUARTERS:
Velcon Filters, LLC
1210 Garden of the Gods Road
Colorado Springs, CO 80907-3410
Phone: 1.800.531.0180 / 1.719.531.5855
Fax: 719.531.5690
e-mail: vfsales@velcon.com
www.velcon.com

MANUFACTURING PLANTS LOCATED AT:
Colorado Springs, Colorado
Sylacauga, Alabama
Henryetta, Oklahoma

OFFICES AND AFFILIATES IN:
Canada, Germany, Singapore & Spain



Liquid Filtration
and Separation
Specialists

Due to Velcon Filters' continuing product improvement, drawings, specifications and pictures are subject to change without notice.

Buy: www.ValinOnline.com | Phone 844-385-3099 | Email: CustomerService@valin.com

MP5 SPECIFICATIONS

Standard features, all MP5 Models

- 5 gpm flow rate
- Powder coated interior and exterior
- 100 psi design pressure
- Welded steel construction
- 10" semi-pneumatic wheels
- Self-priming positive displacement pump with built-in pressure relief valve
- Static pressure gauge – indicates need for cartridge change
- ½ hp, 115V, 1-phase, 60 Hz, 10 Amp TEFC motor
- 10 ft. 3-wire power cord
- 10 ft. inlet and discharge hose, ¾" I.D.
- ¾" NPT male fittings on hose ends
- Suction Y-strainer mounted at pump inlet
- Weight: 116 lbs.
- Shipping weight: 139 lbs.
- Height: 38"; Width: 13¼"; Length: 26"

FILTER CARTRIDGES

The MP5 portable filter accepts all Velcon standard 618/718 size cartridges. Contact your local Velcon representative for a complete listing of available cartridges and their applications.

Dirt Removal: For particulate solids, use FO-718PL Series large surface area pleated media cartridges, available in micron ratings from 0.3 to 50. For colloidal contaminants, FO-618FGA Series Fiberglass depth cartridges, available in micron ratings from 5 to 25, are recommended.

Dirt and Free Water Removal: Use *Aquacon*® AC-718 super absorbent cartridges to remove up to two quarts of free water and also filter particulate solids. Available in micron ratings from 0.3 to 5.

Dissolved Water Removal: Use *Superdri*® cartridge model SD-718 to remove dissolved water from insulating oil. Specify Flow Control Bypass option to reduce 5 gpm flow rate to 3 gpm recommended flow rate for SD-718 cartridge.



ORDERING INFORMATION

Specify Model numbers as shown below. Units are shipped without cartridge.

MP5-1	115 vac, 1 phase, 60 Hz (basic unit)
MP5XP-1	115 vac, 1 phase, 60 Hz, explosion proof*
MP5-2	230 vac, 1 phase, 60 Hz
MP5XP-2	230 vac, 1 phase, 60 Hz, explosion proof*
MP5-7	230 vac, 1 phase, 50 Hz
MP5-10	Air Motor

For stationary base mounted unit, substitute "S" in the model number in place of the "P", e.g., MS5-1.

*Note: Explosion proof units shipped without power cord, switch or plug.

OPTIONS & ACCESSORIES

- 550Y020 Flow Control Bypass** – Allows manual adjustment of flow rate, controls pump cavitation
- 552Y030 Filter Bypass** – Transfer oil without filtration
- 703Y004 Delta P Gauge** – Direct reading 0 - 50 psid differential pressure gauge
- 722Y006 Digital Flowmeter** – Direct Reading, displays flow rate, total flow volume, total resettable batch flow volume

RECOMMENDED SPARES

Filter Cartridge, box of 6

G-1045 Std Buna-N Filter Housing Lid Gasket, 1 ea (or)

G-1045A Viton-A Filter Housing Lid Gasket, 1 ea



Velcon products are sold and serviced by a world-wide representative network. To order, contact Headquarters or your **LOCAL REPRESENTATIVE**:

COMPANY HEADQUARTERS:
Velcon Filters, Inc.
1210 Garden of the Gods Road
Colorado Springs, CO 80907-3410
Phone: 1.800.531.0180 / 1.719.531.5855
Fax: 719.531.5690
e-mail: vfsales@velcon.com
www.velcon.com

MANUFACTURING PLANTS LOCATED AT:
Colorado Springs, Colorado
Sylacauga, Alabama
Henryetta, Oklahoma

OVERSEAS AFFILIATES:
Frankfurt, Germany & Singapore

**Liquid Filtration
and Separation
Specialists**