



# Small Filter Housings

## VF-31E, VF-61, VF-609

### Clean Dry Fuels and Oils with High Performance

#### FEATURES

- Wide variety of applications
- Free and emulsified water to less than 5 ppm
- 1/2 micron particulate removal
- Provides protection against “slugs” of water
- Pressure increase signals cartridge change

These filter housings are versatile housings designed for use with several different high performance **Aquacon**® and other filter cartridges. Refer to the cartridge selection table on page 3 for application and other details.

**Aquacon**® cartridges filter out water by chemically locking it into layers of super-absorbent media. Water capacity is as much as 1½ quarts, depending on the specific vessel and cartridge. These cartridges also effectively filter out dirt, rust and other particulates. (See caution, back cover.)

As an **Aquacon**® cartridge reaches its water-holding limit, the media expands very rapidly and restricts the flow. The pressure drop will rapidly increase, signaling the need to change cartridges.

The VF-61, with **Aquacon**® ACO series cartridges installed, has become the standard for low flow rate full flow aviation fuel monitor applications.

#### APPLICATIONS

- |                     |                    |
|---------------------|--------------------|
| • Jet Fuel          | • Oils: Insulating |
| • Avgas             | Hydraulic          |
| • Motor Gasoline    | Lubricating        |
| • Diesel Fuel       | • Compressed Air   |
| • Biodiesel         | • Other Gasses     |
| • Selected Solvents |                    |



VF-31E



VF-61\*



VF-609



VF-61 connected to a diesel fuel dispenser

**\*Also available: VF-61UL Filter Housing, for diesel fuels. Recognized under the Component Recognition Program of Underwriters Laboratories Inc.**

## ORDERING INFORMATION

(Please note: Cartridges are NOT supplied. They must be ordered separately)

HOUSING P/N:	VF-31E	VF-61	VF-609
<b>SUPPLIED WITH:</b>	<ul style="list-style-type: none"> <li>1 ea P/N G-0995 Buna-N O-ring</li> <li>Mounting holes in head - 4 ea 1/4-20 NC</li> <li>1 ea plug (for fuel &amp; oil applications)</li> <li>1 ea 1/8" petcock drain (for air, gas, &amp; aviation fuel applications)</li> </ul>	<ul style="list-style-type: none"> <li>1 ea P/N G-0986 Buna-N O-ring</li> <li>1/8" brass petcock vent valve, installed</li> <li>1/2" drain plug, installed</li> <li>1 ea 1/2" petcock drain, shipped loose</li> </ul>	<ul style="list-style-type: none"> <li>1 ea P/N G-0565 Buna-N O-ring</li> <li>1/4" brass petcock vent valve</li> <li>1/2" drain valve</li> </ul>
<b>RECOMMENDED SPARES</b>	<ul style="list-style-type: none"> <li>1 ea P/N G-0995 Buna-N O-ring</li> <li>4 ea replacement filter cartridges</li> </ul>	<ul style="list-style-type: none"> <li>1 ea P/N G-0986 Buna-N O-ring</li> <li>6 ea replacement filter cartridges</li> </ul>	<ul style="list-style-type: none"> <li>1 ea P/N G-0565 Buna-N O-ring</li> <li>6 ea replacement filter cartridges</li> </ul>
<b>If using with gasoline/solvent applications:</b>		<ul style="list-style-type: none"> <li>2 ea P/N G-0986A Viton O-rings</li> </ul>	<ul style="list-style-type: none"> <li>2 ea P/N G-0565A Viton O-rings</li> </ul>
<b>OPTIONS</b>	N/A	<ul style="list-style-type: none"> <li>P/N 554Y020 - (carbon steel 1/2" NPT ball valve, with mounting nipple)</li> <li>P/N 10678 - (differential pressure gauge assembly)</li> <li>P/N CK-1488 (quick release hand bolts)</li> </ul>	<ul style="list-style-type: none"> <li>P/N 554Y020 - (carbon steel 1/2" NPT ball valve, with mounting nipple)</li> <li>P/N 07-224 - (differential pressure gauge assembly)</li> <li>PN 07-224AMB (mounting block)</li> </ul>
<b>SPECIFICATIONS</b>			
<b>Weight</b>	3 lbs, 15 oz	8 lbs	8 lbs
<b>Shipping Weight</b>	4 lbs, 15 oz	10 lbs	10 lbs
<b>Inlet/Outlet Connection</b>	1" NPT	1 1/2" NPT	1 1/2" NPT
<b>Cover</b>	Bolted	Bolted, 4 bolts	Bolted, 4 bolts
<b>Maximum Operating Pressure: 150 psi</b>			
<b>Material: Cast aluminum head, carbon steel shell with epoxy powder coated exterior &amp; interior</b>			

### OVER PRESSURE PROTECTION

When exposed to a high concentration of water, the differential pressure across an absorbent cartridge (AC, ACO, AD, or ASL Series cartridges) will immediately increase. Pressure bypasses or other means to limit the inlet pressure to 75 psi (5 bar) should be installed to prevent cartridge from collapsing.

### CAUTION

To protect the fuel system, including the VF-609 & other components, be sure to install pressure relief valve(s).

### CAUTION

Do not use **Aquacon**<sup>®</sup> absorbent cartridges (AC, ACO, AD or ASL Series) with pre-mixed jet fuel containing anti-coring additives, or with gasoline/alcohol blends.



Velcon products are sold and serviced by a world-wide representative network. To order, contact Headquarters or your LOCAL REPRESENTATIVE:

**COMPANY HEADQUARTERS:**  
 Velcon Filters, Inc.  
 1210 Garden of the Gods Road  
 Colorado Springs, CO 80907-3410  
 Phone: 1.800.531.0180 / 1.719.531.5855  
 Fax: 719.531.5690  
 e-mail: vfsales@velcon.com  
 www.velcon.com

**MANUFACTURING PLANTS LOCATED AT:**  
 Colorado Springs, Colorado  
 Sylacauga, Alabama  
 Henryetta, Oklahoma

**OVERSEAS AFFILIATES:**

**Liquid Filtration  
and Separation  
Specialists**



# Filter Housing VF-62

## Clean Dry Fuels and Oils with High Performance Aquacon® Filter Cartridges

### FEATURES

- Free and emulsified water to less than 5 ppm
- 1/2 micrometer particle removal
- Provides protection against “slugs” of water
- Pressure increase signals cartridge change

### DESCRIPTION

The VF-62 is a versatile filter housing designed for use with several different high performance **Aquacon** filter cartridges. Refer to the cartridge selection table on the reverse side.

**Aquacon** cartridges filter out water by chemically locking it into layers of super-absorbent media. Water removal efficiency is not affected by common surfactants or additives. Water capacity is as much as 3 quarts, depending on the flow rate. These cartridges also effectively filter out dirt, rust and other particles. (See caution below, right.)

As a cartridge reaches its water-holding limit, the media expands very rapidly and restricts the flow. The pressure drop will rapidly increase, signaling the need to change cartridges.

The VF-62, with ACO series cartridges installed, will soon become the standard for low flow rate full flow aviation fuel monitor applications.



VF-62 shown with optional quick release hand bolts.

### APPLICATIONS

- |                |                   |
|----------------|-------------------|
| Jet Fuel       | Insulating Oil    |
| Avgas          | Hydraulic Oil     |
| Motor Gasoline | Lubricating Oil   |
| Diesel Fuel    | Selected Solvents |
| Biodiesel Fuel |                   |

### \*\*\*\*\*CAUTION\*\*\*\*\*

DO NOT USE WITH PRE-MIXED JET FUEL  
CONTAINING ANTI-ICING ADDITIVES.

**WARNING:** Absorbent-type monitor cartridges will not remove water from fuel containing alcohol-blending agents (commonly called gasohol). For removal of solids, please use Velcon particle removal filters specifically made for gasohol. Consult your Velcon representative.

## SPECIFICATIONS

### Filter Housing VF-62

- Maximum Operating Pressure: 150 psi
- Material: die cast aluminum head and closure clamp assembly; carbon steel shell with epoxy coated exterior and interior.
- Inlet/Outlet Connection: 1 1/2" NPT
- Closure Seal: Buna-N O-Ring (P/N G-0986)
- Weight: 16 lbs., Shipping Weight: 18 lbs.
- 1/8" brass petcock vent valve and 1/2" drain valve

### Cartridges

- Maximum Operating Temperature: 200°F
- Collapse Strength: 75 psi (5 bar)
- pH Range: 5 - 9
- Nominal Filtration Efficiency: 98%

### Over Pressure Protection

- When exposed to a high concentration of water, the differential pressure across an **Aquacon**® cartridge will immediately increase. Pressure bypasses or other means to limit the inlet pressure to 75 psi (5 bar) should be installed to prevent the cartridge from collapsing.

## FILTER CARTRIDGE SELECTION TABLE

Application	Cartridge	Rating	Typical Free Water in Effluent (Maximum)	Recommended Flow Rates
Jet Fuel (1) Avgas (1)	ACO-52401L	1/2	2 ppm	10-100 USGPM (2)
Motor Gasoline	AC-52405	5	5 ppm	10-100 USGPM
Diesel Fuel	AD-52425	25	50 ppm	30-100 USGPM
Oils	AC-52405	5	See Note (3)	Varies with viscosity See Form #1709
	AD-52425	25		
Solvents	ASL-52401	1	5 ppm	10-100 USGPM
Dirt Removal Only	FO-524PL05	5	N/A	2-100 USGPM
	FO-524PL1/2	1/2		
	FO-524PL25	25		

### NOTES:

- (1) For Aviation Fuels, if system pressure can exceed 25 psi, and for Diesel Fuel Systems, always install pressure gauge or other means of determining differential pressure.
- (2) For Full Flow Fuel Monitor applications, the flow rate can be increased to 100 USGPM. This will result in a somewhat reduced cartridge life and higher initial pressure drop. In jet fuel with an ACO-52401L installed, the initial pressure drop is 6 psi at 50 USGPM, 10 psi at 75 USGPM.
- (3) For oils and other liquids with viscosity above 100 SUS, more than one pass is typically required through the cartridge. After multiple passes, water levels of 5 ppm can be achieved.

## ORDERING INFORMATION

- Specify Model VF-62 Filter Housing
- Unit is supplied with G-0986 Buna-N O-Ring and 1/8" valve and 1/2" drain plug installed. 1/2" petcock drain valve is shipped loose.
- Cartridges are not supplied and must be ordered separately.
- Viton O-Rings (P/N G-0986A) are available but must be ordered separately. They are recommended for gasoline and solvent applications.
- Optional Differential Pressure Gauge Assembly is Part Number 10678 (See Form #1959)

## VESSEL DIMENSIONS

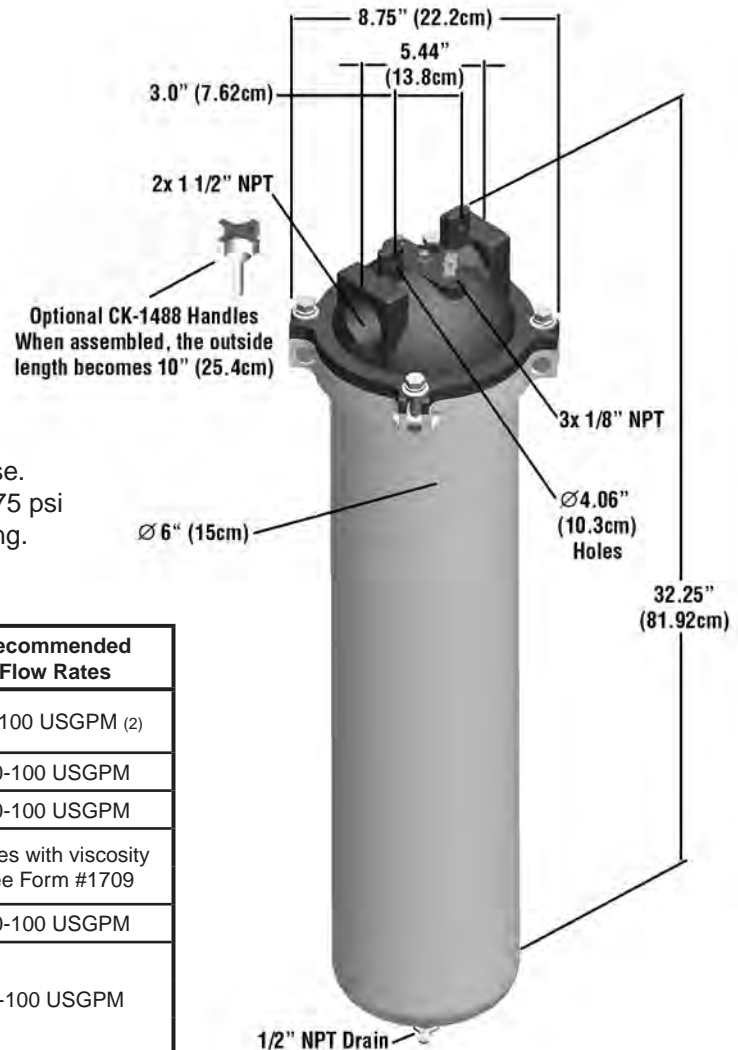

## RECOMMENDED SPARES

- 1 each G-0986 Buna-N O-Ring
- 6 each Cartridges
- If Viton O-Rings are desired, 2 each G-0986A

## OPTIONS

- Part Number 554Y020 is a Carbon Steel 1/2" NPT Ball Valve, with Mounting Nipple
- Part Number CK-1488 quick release hand bolts (set of 4) to replace closure bolts (as shown on page 1)

Velcon products are sold and serviced by a world-wide representative network. To order, contact Headquarters or your LOCAL REPRESENTATIVE:

COMPANY HEADQUARTERS:  
 Velcon Filters, LLC  
 1210 Garden of the Gods Road  
 Colorado Springs, CO 80907-3410  
 Phone: 1.800.531.0180 / 1.719.531.5855  
 Fax: 719.531.5690  
 e-mail: vfsales@velcon.com  
 www.velcon.com

MANUFACTURING PLANTS LOCATED AT:  
 Colorado Springs, Colorado  
 Sylacauga, Alabama  
 Henryetta, Oklahoma

OFFICES AND AFFILIATES IN:  
 Canada, Germany, Singapore, & Spain



**Liquid Filtration  
 and Separation  
 Specialists**

Due to Velcon Filters' continuing product improvement, drawings, specifications and pictures are subject to change without notice.

Buy: [www.ValinOnline.com](http://www.ValinOnline.com) | Phone 844-385-3099 | Email: [CustomerService@valin.com](mailto:CustomerService@valin.com)