

Filter Selection Table



Portable Filter Pumps



MP5
(#1535)
MP1EG
(#1721)
MP5E
(#1661)



MCP5E/MDP5E
(#1691)
AVF
(#2023)
HP10/HP30
(#1604)

Stationary Housings



VF-62
(#2076)
VF-61
(#1997)
VF-609
(#1997)
VF-31E
(#1997)



Vel-Max®
(#1961)
VF-71E
(#1654)
VF-166C/VF-2012C
(#1588)
VF82B
(#1708)

Filter Systems



TOC30 (#1751)
TOC5 (#1857)
HCP/HDP (#1693)

Typical Solutions for Industrial Applications Equipment/Cartridge Combinations

For more detailed information, please refer to individual data sheets as indicated by the form # listed below photos or in parenthesis in the table.

Problem	Type of Fluid/Applications	Solution
1. Water and Dirt in Oils	Lube Oil Gear Oil Hydraulic Oil Turbine Oil	1a. Portable Filter Pumps The MP5, 5 GPM Portable Filter Pump is typical and widely used in industry. Use with Aquacon® cartridge (#1582) or FO-718PL pleated media (#1549)
		1b. Stationary Filter Housings and Aquacon® Cartridges Note that Aquacon® super-absorbent filters have become the industry standard for dirt and water removal. See #1770 for more info.
		1c. Turbine Oil Coalescing System (#1751, 1857) Use TOC30 System at 30GPM flow rate.
2. Water and Carbon in Insulating Oils	Transformer Oil Circuit Breaker Oil Switch Gear Oil Tap Changer Oil	2a. Aquacon® Cartridges in Portable Filter Pumps MP-5 at 5 GPM and HP-30 at 30GPM flow rate.
		2b. Insulating Oil Filter Systems Use Aquacon® Cartridges in HCP-30 and TO-30 Systems at 30GPM flow rates.
		2c. Aquacon® 1, 2, 3, and 4-Hi Cartridges (#1684) Replacements for Alsop and Cuno disk type cartridges and Hilco blotter paper filters in existing housings.
3. Water and Dirt in Fuels	Gasoline Diesel Kerosene	3a. Aquacon® Cartridges in VF-61, VF-62 or VF-31E Housings (#1655) Positive Shut-Off features prevents pumping of contaminated fuel. Use Coalescer Cartridges in high volume applications.
		3b. Spin-On Aquacon® Cartridges (#1717) Use on gasoline and diesel fuel dispensers.
		4. High Surface Area Pleated Media and Fiberglass Depth Media Cartridges (#1550) Use in Stationary Housings at 1 to 600 GPM or Portable Filter Pumps at 1 to 30 GPM.
4. Dirt (Particulates) In Oils and Fuels	All Oils All Fuels	
5. Acid in Oils	Vacuum Pump Oil	5. Adsorbent Cartridges: Fullers Earth or Activated Alumina (#1667) Use in Stationary Housings or Portable Filter Pumps.
6. Water and Dirt in Compressed Air	Industrial Compressed Air Instrument Air	6. Air Aquacon® Filter Cartridge in VF-31E Housing (#1689) "Foolproof" 99.9+% water removal with positive lock-in and positive shut-down. Gross water removal via petcock.
7. Water and Dirt in Solvents	Hexane Toluene 1,1,1 -Trichlorene	7. Solvent Aquacon® Cartridges (#1692) Use in Stationary Housings. Typical: 1 to 80 GPM, down to 10 ppm water in effluent with 1 micrometer particulate rating.

Buy: www.ValinOnline.com | Phone 844-385-3099 | Email: CustomerService@valin.com

Aquacon® Cartridges



Aquacon® - Industrial
(#1582)



Air Aquacon® ACA-210
(#1689)



Aquacon® Spin-on Industrial
(#1717)

Other Filter Cartridges



Synthetic FOS
(#1734)



Fiberglass FO-xxxFG
(#1550)



Pleated Filters
(#1549)



Coalescers
(#1561)



Adsorbent LA-6xx
(#1667)

Benefits

- Reduced operating costs by removing particulates that can cause engine damage
- Reliable fuel injector performance when particulate contaminants are removed to meet ISO 4406 Cleanliness Standards
- Improved equipment uptime, reduces equipment failures, repairs, and/or replacements

Product Specifications

- All filter components compatible with diesel and biodiesel blends
- Recommended change out pressure: 25 psid (1.7 bar)
- Buna-N sealing materials are standard
- Maximum Operating Temperature: 225°F (107°C)

Recommended Housings (See Pages 13-16 for details)



DFO Part Numbering

Velcon recommends use of threaded base endcaps for ease of installation and to minimize components.

	O.D. in. (mm)	Length in. (mm)		Micron Rating (µm)	Endcap Options
DFO —	5 5 5/8 (143)	12 – 12 (305) 24 – 24 (610)	PLF	2, 4, 6, 10, 25, 40	
DFO —	6 6 (152)	14 – 14 5/8 (371) 29 – 29 1/8 (740) 36 – 36 (915) 44 – 44 1/8 (1121) 56 – 56 1/8 (1426)	PLF	2, 4, 6, 10, 25, 40	TB (Threaded base)

Example:
DFO-614PLF25

Variables that often change for the DFO part numbers when placing an order are the length and the µm ratings; as seen in the case of the above example with number 14 (length) and number 25 (µm rating)

NOTE: Other lengths and end fittings available. Please contact Velcon for further assistance.

Product Specifications

- All filter components are compatible with diesel and biodiesel blends
- Recommended change out pressure: 25 psid (1.7 bar)
- Water absorbance and particulate retention will increase differential pressure to the change out pressure
- Buna-N sealing materials are standard
- Maximum Operating Temperature: 150°F (65°C)
- All AD products will remove free and emulsified water from both diesel and biodiesel fuels to levels below 50 ppm
- The water absorbing technology used in AD filters is not effective in the presence of fuels containing high concentrations of alcohol

Recommended Housings (See Pages 13-16 for details)



AD Part Numbering

Velcon recommends use of threaded base endcaps for ease of installation and to minimize components.

	O.D. in (mm)	Length in. (mm)	Micron Rating (µm)	Endcap Options	<i>Example:</i>
AD —	5 5.5 (143)	12 – 12 (305) 24 – 24 (610)	2, 4, 6, 10, 25, 40		AD-5122
AD —	6 6 (152)	14 – 14 5/8 (371) 29 – 29 1/8 (740) 36 – 36 (914) 44 – 44 1/8 (112) 56 – 56 1/8 (143)	2, 4, 6, 10, 25, 40	TB (Threaded base)	Variables that often change for the AD part numbers when placing an order are the length and the µm ratings; as seen in the case of the above example with number 12 (length) and number 2 (µm rating).

NOTE: Other lengths and end fittings available. Please contact Velcon for further assistance.

VF-61, VF-62

Small Housings for Diesel Fuel Filtration

Product Specifications

- Max. Operating Pressure: 150 psi
- Inlet/Outlet connection: 1-1/2" NPT
- Closure Seal: Buna-N O-ring (P/N G-0986)
- 1/8" brass petcock vent valve and 1/2" drain valve
- Material: Die cast aluminum head and closure clamp assembly; carbon steel shell with epoxy coated exterior and interior
- Weight:
 - VF-61: 4.54 kg (10 lbs), Shipping weight: 5.44 kg (12 lbs)
 - VF-62: 7.26 kg (16 lbs), Shipping weight: 8.17 kg (18 lbs)

Optional Features

- dP Gauge



VF-61 (For use with AD-5 and DFO-5 Cartridges)

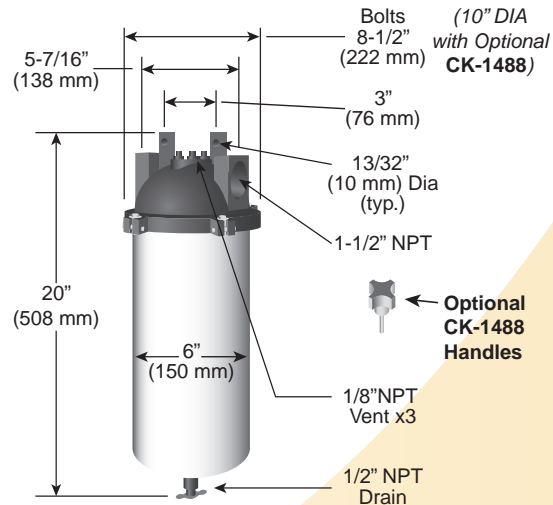

VF-62 (For use with AD-5 and DFO-5 Cartridges)

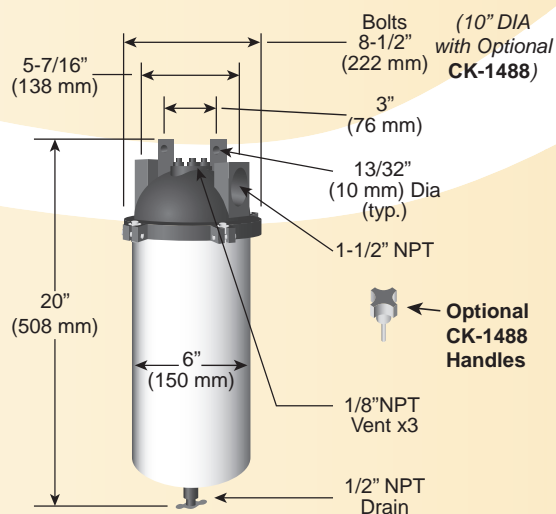

Dimensions shown are for estimating purposes only. For exact dimensional detail, obtain certified copy of vessel drawing.

VF-61 Differential Pressure Gauge

Assembly Part Number 10678
For Use with VF-61, VF-61E, VF-62



Description

This unit measures pressure difference between two points. The gauge allows for a simple reading on an easy-to-read scale. A red/green dial with a breakpoint located at 15 psid alerts the user of the condition of the process.

This kit consists of the following components:

- Differential Pressure Gauge: aluminum body, 1/8" NPT bottom, 1" molded lens & 0-20 psid scale,
- Compression Fittings: 4 straight, 2 90° elbow
- 1/4 O.D. Copper Tubing

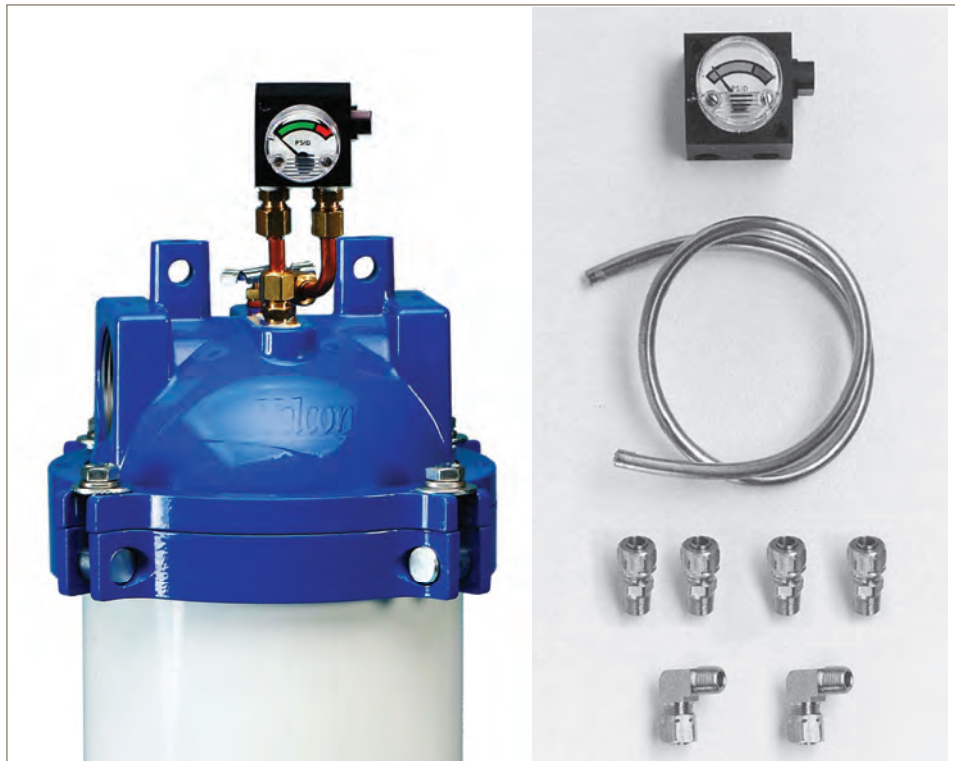

Contact Information: Operation:

Parker Hannifin Corporation
Velcon Filtration Division
1210 Garden of the Gods Road
Colorado Springs, CO 80907

tel +1 719 531 5855
fax +1 719 531 5690
vfsales@parker.com

www.velcon.com

When the needle is in the green zone of the gauge during normal flow, the differential pressure is less than 15 psid across the installed element, and the element does not need to be changed out.

When the needle is in the red zone, the differential pressure is more than 15 psid and the element should be changed out. It has reached its recommended maximum pressure differential.

CAUTION:

Do not mount the P/N 10678 differential pressure gauge assembly any closer than 2" from a steel bracket or pipe. The gauge has a magnetic piston, and mounting too close to steel may affect the accuracy.



ENGINEERING YOUR SUCCESS.

Aquacon[®] Air Filter

Cartridge Model ACA-210

Housing Model VF-31E

Water Removal from Compressed Air

FEATURES

- Minimal routine maintenance
- 99.9+% Water-Free Air
- Efficient particulate removal
- Residual oil mist removal

APPLICATIONS

- Spray Painting
- Instrument Air
- Air Bearings
- Fluidic Controls
- Gas Chromatography
- Gas Sampling Equipment
- Machine Tools
- Air Driven Hand Tools
- Etching Tools
- Servo Pneumatic Control Systems
- Sand Blasting Equipment
- Compressed Air Cleaning

GENERAL DESCRIPTION

Aquacon super-absorbent cartridges remove 99.9+% of liquid water from compressed air. This is considered to be “total” water removal for many industrial and scientific applications. Note that water vapor is not removed.

Filtered water is locked into the super-absorbent media and cannot be squeezed out. When a cartridge reaches its water holding limit, the media expands and restricts the flow of unfiltered air until the cartridge is replaced. Periodic draining of the sump will extend cartridge life by keeping accumulated water away from the super-absorbent media.

Aquacon Cartridges are also excellent dirt filters. They are rated at 99.9+% for particles down to 1 micrometer. In addition, the cartridges remove residual oil mist that may have gotten past a primary filter.

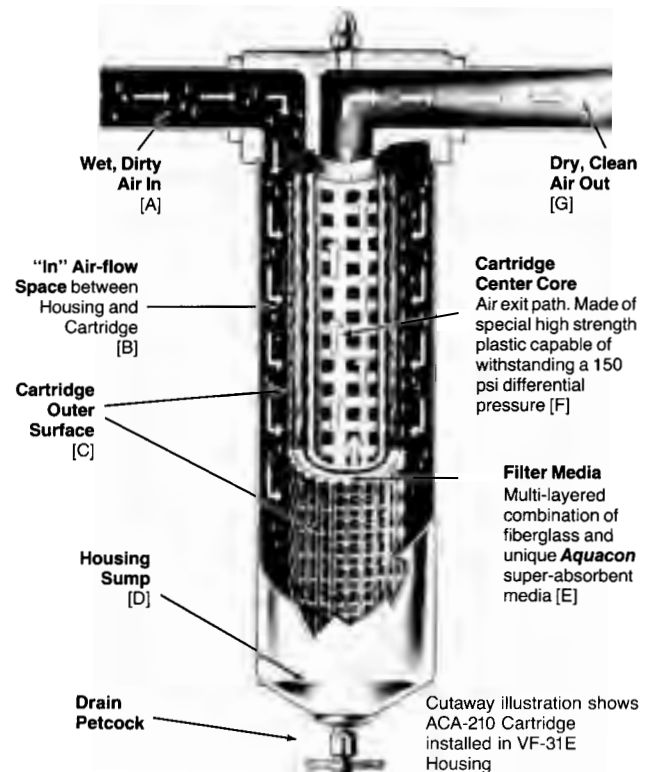

HOW IT WORKS

- (1) **Wet, Dirty Air** [A] flows into housing and down into space between housing and cartridge [B].
- (2) **Gross Water** coalesces in large drops on the cartridge’s outer surface [C] and drips down into the housing sump [D].
- (3) **Finely Dispersed Water Mist** penetrates into the cartridge’s multi-layered filter media [E] where it is absorbed and “locked-in” to the super-absorbent water media layers. When saturated, this media swells up and restricts airflow.
- (4) **Dirt Particles** are filtered by the fiberglass layers of the multi-layered filter media [E]. When fully loaded with dirt, the cartridge plugs up like any conventional filter.
- (5) **Residual Oil Mist** – Oil drops coalesce on the cartridge surface [C] and fall into the vessel sump [D]. Some oil mist penetrates into the cartridge and is trapped in voids in the fiberglass media layers [E]. Oil removal capacity is limited.
- (6) **Dry, Clean Air** passes up through Center Core [F] and out [G].

SPECIFICATIONS

Filter Housing VF-62

- Maximum Operating Pressure: 150 psi
- Material: die cast aluminum head and closure clamp assembly; carbon steel shell with epoxy coated exterior and interior.
- Inlet/Outlet Connection: 1 1/2" NPT
- Closure Seal: Buna-N O-Ring (P/N G-0986)
- Weight: 16 lbs., Shipping Weight: 18 lbs.
- 1/8" brass petcock vent valve and 1/2" drain valve

Cartridges

- Maximum Operating Temperature: 200°F
- Collapse Strength: 75 psi (5 bar)
- pH Range: 5 - 9
- Nominal Filtration Efficiency: 98%

Over Pressure Protection

- When exposed to a high concentration of water, the differential pressure across an **Aquacon**® cartridge will immediately increase. Pressure bypasses or other means to limit the inlet pressure to 75 psi (5 bar) should be installed to prevent the cartridge from collapsing.

FILTER CARTRIDGE SELECTION TABLE

Application	Cartridge	Rating	Typical Free Water in Effluent (Maximum)	Recommended Flow Rates
Jet Fuel (1) Avgas (1)	ACO-52401L	1/2	2 ppm	10-100 USGPM (2)
Motor Gasoline	AC-52405	5	5 ppm	10-100 USGPM
Diesel Fuel	AD-52425	25	50 ppm	30-100 USGPM
Oils	AC-52405	5	See Note (3)	Varies with viscosity See Form #1709
	AD-52425	25		
Solvents	ASL-52401	1	5 ppm	10-100 USGPM
Dirt Removal Only	FO-524PL05	5	N/A	2-100 USGPM
	FO-524PL1/2	1/2		
	FO-524PL25	25		

NOTES:

- (1) For Aviation Fuels, if system pressure can exceed 25 psi, and for Diesel Fuel Systems, always install pressure gauge or other means of determining differential pressure.
- (2) For Full Flow Fuel Monitor applications, the flow rate can be increased to 100 USGPM. This will result in a somewhat reduced cartridge life and higher initial pressure drop. In jet fuel with an ACO-52401L installed, the initial pressure drop is 6 psi at 50 USGPM, 10 psi at 75 USGPM.
- (3) For oils and other liquids with viscosity above 100 SUS, more than one pass is typically required through the cartridge. After multiple passes, water levels of 5 ppm can be achieved.

ORDERING INFORMATION

- Specify Model VF-62 Filter Housing
- Unit is supplied with G-0986 Buna-N O-Ring and 1/8" valve and 1/2" drain plug installed. 1/2" petcock drain valve is shipped loose.
- Cartridges are not supplied and must be ordered separately.
- Viton O-Rings (P/N G-0986A) are available but must be ordered separately. They are recommended for gasoline and solvent applications.
- Optional Differential Pressure Gauge Assembly is Part Number 10678 (See Form #1959)

VESSEL DIMENSIONS

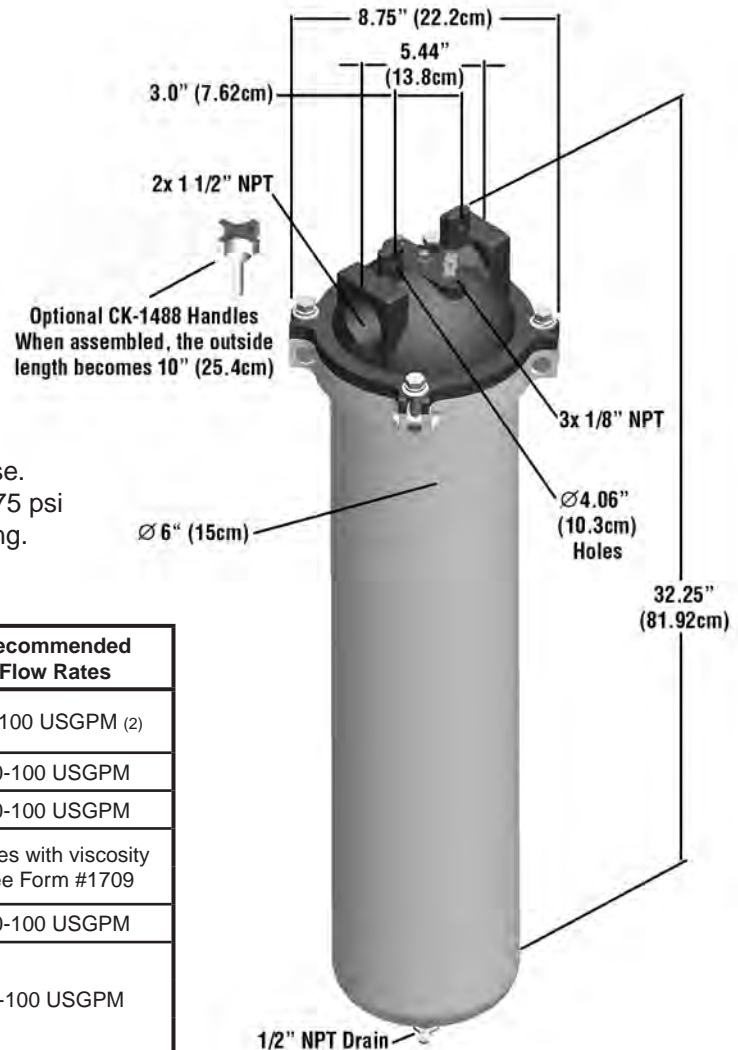

RECOMMENDED SPARES

- 1 each G-0986 Buna-N O-Ring
- 6 each Cartridges
- If Viton O-Rings are desired, 2 each G-0986A

OPTIONS

- Part Number 554Y020 is a Carbon Steel 1/2" NPT Ball Valve, with Mounting Nipple
- Part Number CK-1488 quick release hand bolts (set of 4) to replace closure bolts (as shown on page 1)



Velcon products are sold and serviced by a world-wide representative network. To order, contact Headquarters or your LOCAL REPRESENTATIVE:

COMPANY HEADQUARTERS:
 Velcon Filters, LLC
 1210 Garden of the Gods Road
 Colorado Springs, CO 80907-3410
 Phone: 1.800.531.0180 / 1.719.531.5855
 Fax: 719.531.5690
 e-mail: vfsales@velcon.com
 www.velcon.com

MANUFACTURING PLANTS LOCATED AT:
 Colorado Springs, Colorado
 Sylacauga, Alabama
 Henryetta, Oklahoma

OFFICES AND AFFILIATES IN:
 Canada, Germany, Singapore, & Spain



**Liquid Filtration
 and Separation
 Specialists**

Due to Velcon Filters' continuing product improvement, drawings, specifications and pictures are subject to change without notice.

Buy: www.ValinOnline.com | Phone 844-385-3099 | Email: CustomerService@valin.com

VF-61 Differential Pressure Gauge

Assembly Part Number 10678
For Use with VF-61, VF-61E, VF-62



Description

This unit measures pressure difference between two points. The gauge allows for a simple reading on an easy-to-read scale. A red/green dial with a breakpoint located at 15 psid alerts the user of the condition of the process.

This kit consists of the following components:

- Differential Pressure Gauge: aluminum body, 1/8" NPT bottom, 1" molded lens & 0-20 psid scale,
- Compression Fittings: 4 straight, 2 90° elbow
- 1/4 O.D. Copper Tubing

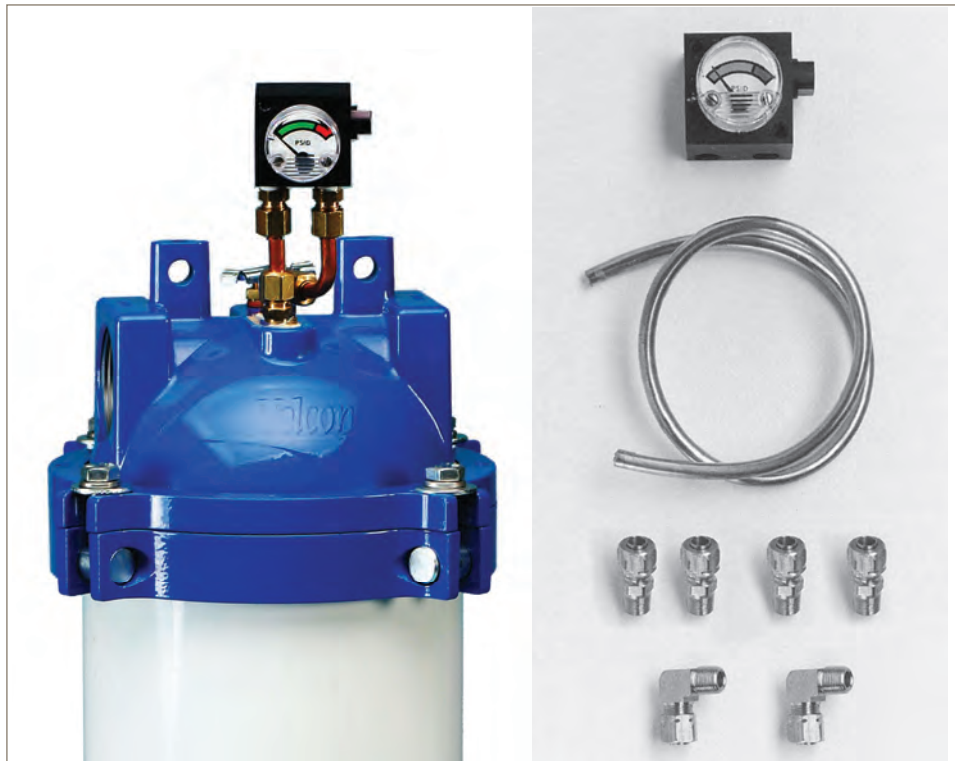

Contact Information: Operation:

Parker Hannifin Corporation
Velcon Filtration Division
1210 Garden of the Gods Road
Colorado Springs, CO 80907

tel +1 719 531 5855
fax +1 719 531 5690
vfsales@parker.com

www.velcon.com

When the needle is in the green zone of the gauge during normal flow, the differential pressure is less than 15 psid across the installed element, and the element does not need to be changed out.

When the needle is in the red zone, the differential pressure is more than 15 psid and the element should be changed out. It has reached its recommended maximum pressure differential.

CAUTION:

Do not mount the P/N 10678 differential pressure gauge assembly any closer than 2" from a steel bracket or pipe. The gauge has a magnetic piston, and mounting too close to steel may affect the accuracy.



ENGINEERING YOUR SUCCESS.