

# **INSTRUCTION MANUAL**

---

**INSTALLATION - OPERATION - MAINTENANCE**

**TD SERIES**

**Low Voltage  
Digital Solid State Starter**

**48 - 1250 A**

**Issued: 9/03  
Manufactured in the USA**

# SAFETY

## SAFETY CODES

Toshiba motor control is designed and built in accordance with the latest applicable provisions of NEMA and the National Electrical Code. Installations must comply with all applicable state and local codes, adhere to all applicable National Electric Code (NFPA 70) standards and instructions provided in this manual.

### **HAZARDOUS VOLTAGE will cause severe injury, death, fire, explosion and property damage.**

- Turn off and lock out Primary and Control Circuit Power before servicing.
- Keep all panels and covers securely in place.
- Never Defeat, Modify, or Bypass any Safety Interlocks.
- Qualified Operators only.



**Never attempt to install, operate, maintain or dispose of this equipment until you have first read and understood all of the relevant product warnings and user directions that are contained in this Instruction Manual.**

**Use only Toshiba-authorized replacement parts.**

**This equipment is designed and built in accordance with applicable safety standards in effect on the date of manufacture. Unauthorized modifications can result in voiding the warranty, severe injury, death and property damage. Do not make any modifications to this equipment without the written approval of Toshiba.**

For assistance, address correspondence to:

Toshiba International Corporation  
Field Service Department  
13131 West Little York Road  
Houston, Texas 77041 USA

or call: (713) 466-0277  
(800) 231-1412  
(800) 527-1204 (Canada)

Fax: (713) 466-8773

Please complete the following information for your records and retain with this manual:

Model: \_\_\_\_\_

Serial Number: \_\_\_\_\_

Date of Installation: \_\_\_\_\_

Inspected by: \_\_\_\_\_

Reference Number: \_\_\_\_\_

© TOSHIBA INTERNATIONAL CORPORATION, 2003

# SAFETY

## IMPORTANT MESSAGES

**Read this manual and follow its instructions.** Signal words such as DANGER, WARNING and CAUTION will be followed by important safety information that must be carefully reviewed.

### **DANGER**

Indicates a situation which will result in death, serious injury, and severe property damage if you do not follow instructions.

### **WARNING**

Means that you might be seriously injured or killed if you do not follow instructions. Severe property damage might also occur.

### **CAUTION**

Means that you might be injured if you do not follow instructions. Equipment damage might also occur.

### **NOTE**

Give you helpful information.

**Note: The contents of this manual will not become a part of or modify the warranty policy, the terms of which are set forth at the end of this manual.**

## READ SAFETY SIGNS

To avoid injury, you must read and follow all safety signs.

Keep the safety signs visible and in good shape. Never remove or cover any safety sign.

### **DANGER**

## QUALIFIED OPERATORS ONLY

Only qualified persons are to install, operate, or service this equipment according to all applicable codes and established safety practices.

### **A qualified person must:**

- 1) **Carefully read the entire instruction manual.**
- 2) Be skilled in the installation, construction or operation of the equipment and aware of the hazards involved.
- 3) Be trained and authorized to safely energize, de-energize, clear, ground, lockout and tag circuits in accordance with established safety practices.
- 4) Be trained and authorized to perform the service, maintenance or repair of this equipment.
- 5) Be trained in the proper care and use of protective equipment such as rubber gloves, hard hat, safety glasses, face shield, flash clothing, etc. in accordance with established practices.
- 6) Be trained in rendering first aid.

# Table of Contents

## **TD Series** **Digital Solid State Soft Starter** **48 - 1250A**

<b>Chapter 1: Introduction</b> .....	<b>1</b>
1.1 General	
1.2 Specifications and Performance Features	
<b>Chapter 2: Installation</b> .....	<b>4</b>
2.1 Receiving and Unpacking	
2.2 Location	
2.3 Initial Unit Inspection	
2.4 Warning	
2.5 Mounting and Cleaning	
2.6 Power Terminal Wire Range and Tightening Torque	
2.7 Dimensions	
<b>Chapter 3: Motor Overload Protection</b> .....	<b>7</b>
3.1 Solid State Overload Protection	
3.2 NEMA Class Trip Curves	
<b>Chapter 4: Connections</b> .....	<b>10</b>
4.1 Power Connections	
4.2 Control Connections	
4.3 Interlock Connection	
<b>Chapter 5: Programming</b> .....	<b>13</b>
5.1 Introduction	
5.2 Digital Interface	
5.3 Display Modes	
5.4 Function List	
5.5 Function Descriptions	
<b>Chapter 6: Start-Up</b> .....	<b>32</b>
6.1 Quick Start	
6.2 Start-up Check List	
6.3 Sequence of Operation	
<b>Chapter 7: Fault Conditions</b> .....	<b>35</b>
7.1 Fault Codes and Numbers (In History)	
<b>Chapter 8: Troubleshooting</b> .....	<b>36</b>
8.1 Failure Analysis	
8.2 SCR Testing Procedure	
8.3 Replacing SCR Devices	
8.4 Replacing Printed Circuit Board Assembly	
<b>Chapter 9: Printed Circuit Board Layout</b> .....	<b>41</b>
9.1 Power Board and CPU Board (PC Board Assembly)	
9.2 Typical Wiring Diagram	
<b>Chapter 10: Maintenance/Disposal/Storage</b> .....	<b>43</b>
<b>Appendix 1: Ramp Profile Details</b>	
<b>Appendix 2: Decel Mode Application Considerations</b>	
<b>Appendix 3: Parameter Lock / User Password Instructions</b>	
<b>Appendix 4: Soft Starter Settings</b>	
<b>Warranty Policy</b>	

## Chapter 1 - Introduction 1.1 General

The **TD Series** is a digitally programmable solid state reduced voltage soft starter. Its six SCR design features a voltage/current ramp with an anti-oscillation circuit for smooth load acceleration. The SCRs are sized to withstand starting currents of 500% for 60 seconds (compared to 350% for 30 seconds from other manufacturers). The **TD Series** features smooth, stepless ramp control which reduces motor inrush current and excessive wear on the mechanical drive train components. In addition to having easy to understand diagnostic LEDs, the **TD Series** includes a programmable keypad for setting operating parameters for the ideal starting cycle. Starting torque, ramp time, current limit, dual ramp, and decel control are standard features on the **TD Series**. By simply adjusting the unit's starting torque, ramp time and current limit functions, the starting electrical characteristics of the motor can be matched to the mechanical characteristics of the drive train for controlled acceleration of the load. The **TD Series** includes solid state electronic overload protection in addition to numerous other protective features. It is factory wired for 120 VAC control voltage and two or three-wire start/stop control (Units can also be ordered with 240 VAC control voltage if required). Programmable auxiliary contacts and provisions for interlocking are also included.

## 1.2 Specifications and Performance Features

Type of Load	Three phase AC induction motor
AC Supply Voltage	208 - 600VAC ±10%, 50/60 Hz
HP Ratings	48 - 1250 Amps, 10 - 1125 HP
Unit Overload Capacity (Percent of motor FLA)	125% - Continuous 500% - 60 seconds 600% - 30 seconds
Power Circuit	6 SCRs
SCR Diode Ratings (Peak Inverse Voltage)	1600V
Phase Insensitivity	Unit operates with any phase sequence
Transient Voltage Protection	RC snubber dv/dt networks on each phase.
Cooling	Convection up to 180A, fan assisted 62 - 120A, Fan ventilated 220 - 1250A
Bypass Contactor	Full horsepower rated contactor included as standard in all Type 12, 3R, 4 & 4X enclosed units 120A and above.
Ambient Condition Design	Chassis units: 0° to 50 °C (32° to 122°F) Enclosed units: 0° to 40°C (32° to 104°F) 5 - 95% relative humidity 0 - 3300 ft. (1000m) above sea level without derating
Control	2 or 3 wire 120VAC (customer supplied) Optional 240VAC control voltage and CPTs are available.
Auxiliary Contacts	Type / Rating: Form C (SPDT), rated 5 Amps, 240VAC max. (1200VA)
	3 Programmable Relays
Approvals	Fault Indicator: AC triac solid state switch 240VAC, 50mA max.
	UL Listed, Canadian UL (cUL) Listed

1.2 Specifications and Performance Features Cont'd

Advanced Motor Protection	
Two Stage Electronic Overload Curves	Starting: Programmable for Class 5 through 30 Run: Programmable for Class 5 through 30 when "At-Speed" is detected.
Overload Reset (Note 1)	Manual (default) or automatic
Retentive Thermal Memory	Overload circuit retains thermal condition of the motor regardless of control power status. Unit uses real time clock to adjust for off time.
Dynamic Reset Capacity	Overload will not reset until thermal capacity available in the motor is enough for a successful restart. Starter learns and retains this information by monitoring previous successful starts.
Phase Current Imbalance Protection (Note1)	Imbalance Trip Level: 5 - 30% current between any two phases Imbalance Trip Delay: 1 -20 seconds
OverCurrent (Electronic Shear Pin) Protection (Note 1)	Trip Level: 50 - 300% of motor FLA Trip Delay: 1 - 20 seconds
Load Loss Trip Protection (Note 1)	Under Current Trip Level: 10 -90 % of motor FLA Under Current Trip Delay: 1 - 60 seconds
Coast Down (Back Spin) Lockout Timer (Note 1)	Coast Down Time Range: 1 - 60 minutes
Starts-per-hour Lockout Timer (Note 1)	Range: 1 - 10 successful starts per hour Time between starts: 1 - 60 minutes between start attempts
Programmable Outputs	
Type / Rating	Form C (SPST), Rated 5 amps 240 VAC max, (1200 VA)
Run Indication	Start/Stop or Start/End of Decel
At Speed Indication	At Speed/Stop or At Speed/End of Decel
Acceleration Adjustments	Programmable Ramp Types: Voltage or Current Ramp (VR or CR) Starting Torque: 0 - 100% of line voltage (VR) or 0 - 600% of motor FLA (CR) Ramp Time: 1 to 120 seconds Current Limit: 200 - 600% (VR or CR)
Dual Ramp Settings	4 Options: VR1+VR2; VR1+CR2; CR1+CR2; CR1+VR2 Dual Ramp Control: Ramp #1 = Default, Ramp = #2 selectable via dry contact input
Deceleration Adjustments	Begin Decel Level: 0 - 100% of line voltage Stop Level: 0 to 1% less than Begin Decel Level Decel Time: 1 - 60 seconds Programmable to decel or coast to stop upon overload trip
Jog Settings Jog function selected via dry contact closure input)	Voltage Jog: 5 - 100% Time of Voltage Jog: 1 - 20 seconds Current Jog: 100 - 500%
Kick Start Settings (Note 1)	Kick Voltage: 10 - 100% Kick Time: 0.1 - 2 seconds
Fault Indications	Shorted SCR, Phase Loss, Shunt Trip, Phase Imbalance Trip, Overload, Overtemp, Overcurrent, Short Circuit, Load Loss, or Any Trip
Lockout Indicator	Coast Down Time, Starts Per Hour, Time Between Starts, and Any Lockout

Note 1: Enabled via programming

1.2 Specifications and Performance Features Cont'd

<b>Metering Functions</b>	
<b>Phase Currents</b>	0 - 9999 Amps, Phase A, B, or C
<b>Remaining Thermal Capacity</b>	0 - 100% of available motor thermal capacity
<b>Elapsed Time</b>	0 - 1,000,000.0 hours, non resetable
<b>Run Cycle Counter</b>	0 - 10,000,000 run commands non resetable
<b>Lockout Time Values</b>	Remaining time of any enabled lockout timer
<b>Fault Codes</b>	Abbreviated fault codes, indicating trip and operating mode
<b>Fault History</b>	Last 3 faults with Time and Date Stamps
<b>Serial Communications</b>	
<b>Protocol</b>	Modbus RTU
<b>Signal</b>	RS-485
<b>Network</b>	Up to 247 devices per mode
<b>Functionality</b>	Full operation, status view, and programming via communications port
<b>Operator Interface</b>	
<b>LED Readout</b>	4 digit alpha numeric, high brightness, 7 segment display
<b>Keypad</b>	8 functions keys with tactile feedback
<b>Status Indicators</b>	8 LEDs
<b>Remote Mount Capability</b>	Up to 10 feet (3 meters) from chassis
<b>Clock and Memory</b>	
<b>Operating Memory</b>	DRAM loaded from EPROM and EEPROM at initialization
<b>Factory Default Storage</b>	Flash EPROM, field replaceable
<b>Customer Settings and Status</b>	Non-volatile EEPROM, no battery backup necessary
<b>Real Time Clock</b>	Lithium ion battery for clock memory only, 10+ years life span

## Chapter 2 - Installation

### 2.1 Receiving and Unpacking

Upon receipt of the product you should immediately do the following:

- Carefully unpack the unit from the shipping carton and inspect it for shipping damage (if damaged, notify the freight carrier and file a claim within 15 days of receipt).
- Verify that the model number on the unit matches your purchase order.
- Confirm that the ratings sticker on the unit matches or is greater than the motor's HP and current rating.

### 2.2 Location

Proper location of the **TD Series** is necessary to achieve specified performance and normal operation lifetime. The **TD Series** should always be installed in an area where the following conditions exist:

- Ambient operating temperature:  
Chassis unit: 0 to 50°C (32 to 122°F)  
Enclosed unit: 0 to 40°C (32 to 104°F)
- Protected from rain and moisture
- Humidity: 5 to 95% non-condensing
- Free from metallic particles, conductive dust and corrosive gas
- Free from excessive vibration (below 0.5G)
- Open panel units must be mounted in the appropriate type of enclosure. Enclosure size and type must be suitable to dissipate heat generated by the soft starter. Contact factory for assistance in sizing enclosures.

### 2.3 Initial Unit Inspection

- Make a complete visual check of the unit for damage which may have occurred during shipping and handling. Do not attempt to continue installation or start up the unit if it is damaged.
- Check for loose mechanical assemblies or broken wires which may have occurred during transportation or handling. Loose electrical connections will increase resistance and cause the unit to function improperly.
- Prior to beginning the installation, verify that the motor and **TD** unit are rated for the proper amperage and voltage.

### 2.4 Warning!



***Do not service equipment with voltage applied! The unit can be the source of fatal electrical shocks! To avoid shock hazard, disconnect main power and control power before working on the unit. Warning labels must be attached to terminals, enclosure and control panel to meet local codes.***

### 2.5 Mounting and Cleaning

When drilling or punching holes in the enclosure, cover the electrical assembly to prevent metal filings from becoming lodged in areas which can cause clearance reduction or actually short out electronics. After work is complete, thoroughly clean the area and reinspect the unit for foreign material. Make sure there is sufficient clearance (six inches) all around the unit for cooling, wiring and maintenance purposes. To maximize effective air flow and cooling, the unit must be installed with its heat sink ribs oriented vertically and running parallel to the mounting surface.



**Remove all sources of power before cleaning the unit.**

In dirty or contaminated atmospheres the unit should be cleaned on a regular basis to ensure proper cooling. Do not use any chemicals to clean the unit. To remove surface dust use 80 to 100 psi, clean, dry compressed air only. A three inch, high quality, dry paint brush is helpful to loosen up the dust prior to using compressed air on the unit.

### 2.6 Power Terminal Wire Range and Tightening Torque

Model Number	Wire range	Torque lbs/in
TD005	#18 - #4	20
TD006	#14 - #2	50
TD007	#6 - 250 kcmil	325
TD008		
TD009	(2) #2 - 600 kcmil	375
TD010		
TD011	(2) #2 - 600 kcmil	375
TD012		
TD013		
TD014	(3) #2 - 600 kcmil	375
TD015		
TD016	(4) #2 - 600 kcmil	375
TD017		

*Note: All wiring must be sized according to NEC standards.*

2.7 Dimensions

TD CHASSIS (PANEL MOUNT) DIMENSIONS						
Model Number	Overall Dimensions (inches)			Mounting Dimensions (inches)		
	A	B	C	D	E	F
TD005A - TD007A	16.5	10	10	15.9	9	0.28
TD008A	20	20.1	12	18.5	17.5	0.44
TD009A - TD010A	27	20.1	11.2	25.5	17.5	0.44
TD011A - TD013A	29.5	20.1	11.5	25.5	17.5	0.44
TD014A - TD015A	45	33	12.8	43.3	31.3	0.44
TD016A - TD017A	33	33	15.2	31.2	31.2	0.44

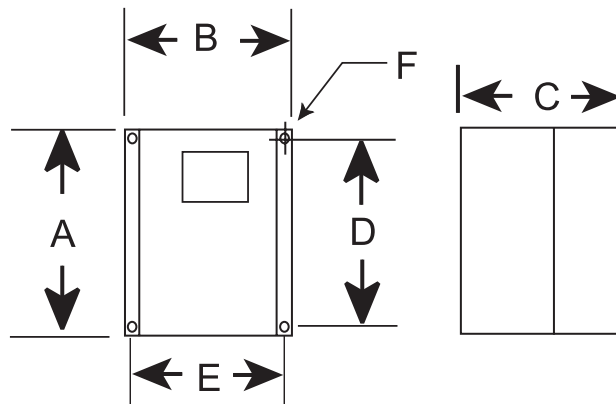

## Chapter 3 - Motor Overload Protection

### 3.1 Solid State Overload Protection

The **TD Series** Starter provides true U.L. listed I<sup>2</sup>T Thermal Overload Protection as a built-in function of the main digital processor. For maximum protection it simulates the tripping action of a bimetallic overload relay, with the accuracy and repeatability of a digital control system, yet is adjustable over a wide range and can be easily programmed for different trip curves.

#### 3.1.1 Thermal Memory

The **TD Series** microprocessor uses a sophisticated “Thermal Register” to keep track of motor heating and cooling over time regardless of the starter’s power status. The **TD Series** does not “forget” that the motor has been running even if power to the starter is turned off and back on. Continuous overload protection is provided based on the true thermal condition of the motor.

#### 3.1.2 Thermal Capacity

The Thermal Register is displayed as a percentage. This percentage is the motor’s remaining thermal capacity. The percentage value begins at 100, showing that the motor is cool. As the motor heats up or moves toward an overload condition, the percentage begins to drop. The Thermal Capacity is derived from the programmed motor nameplate Full Load Amps (FLA) in Function F001, the Service Factor rating in Function F002, and the Overload Trip Class in Functions F003 and F004. Setting these functions to the proper values will provide maximum protection yet eliminates nuisance tripping.

##### 3.1.2.a Motor Full Load (FLA) Setting

Use Function F001 to enter motor FLA as indicated on the motor nameplate. (Do not calculate for service factor, this is programmed separately in F002).

**Note:** If F001 is left at the factory default, the unit will not operate. If the user attempts to start the TD without entering the motor nameplate FLA into this Function, the TD will Fault, and the display will read “nFLA” (for no Full Load Amps).

#### 3.1.3 Disabling the Overload Protection

The Overload Protection feature can be disabled if absolutely necessary. When using external devices such as Motor Protection Relays or when the **TD Series** is wired downstream from an existing starter, this feature can be disabled to prevent conflicts with external overload protection devices. When the **TD Series** is controlling multiple motors, Overload Protection must be disabled. Individual thermal overload relays must be installed on the motor leads going to each motor. To disable the Overload Protection function, use F005. (See Section 5.)



**Do NOT disable Overload Protection unless another Thermal Overload Protection device exists in the circuit for all three phases. Running a motor without Overload Protection presents serious risk of motor damage or fire.**

##### 3.1.3.a Manual Reset

The factory default setting is Manual Reset. This means that when the Overload Trip is activated, the starter cannot be restarted without pressing the **Reset** key. The Overload Trip will not reset until the motor cools down. The Manual Reset function is also “trip free”. Holding in the **Reset** key will not prevent the Overload Trip from activating and protecting the motor.

**Note:** When the Overload Trip activates, the Overload LED will glow solid. When the motor cools down, the LED will begin to flash,

### 3.1.3.b Automatic Reset

If Automatic Reset is necessary, change from Manual Reset to Automatic Reset by using Function F005. (See Section 5 for details). In this mode, a 3-wire control circuit will be capable of restart when the TD Series has reset itself after the cool down period.

**Two-wire control systems may restart without warning when Auto Reset is selected. Extreme caution should be exercised. To prevent automatic restarting with two-wire control systems, use external interlocking to provide sufficient warning and safety to operators. A Warning Label (such as the one provided in the packet with this manual) must be placed to be visible on the starter enclosure and/or the equipment as required by local code.**



**MOTOR CONNECTED TO THIS EQUIPMENT MAY START AUTOMATICALLY WITHOUT WARNING**

## 3.2 NEMA Class Trip Curves

The **TD Series** Soft Starter provides six NEMA Class trip curve options: 5, 10, 15, 20, 25, and 30. Program the appropriate curve according to the characteristics of your motor and load.

NEMA Class trip curves are based on a common tripping point of 600% of rated current. Curves vary by the amount of time before the unit trips. As an example, a Class 20 curve will trip in 20 seconds at 600%. The factory default setting of Class 10 will trip in 10 seconds at 600%.

### 3.2.1 Dual Overload Trip Curves

The **TD Series** Soft Starter provides two separate Overload Trip Protection Curves, one for starting and one for running conditions. Programming a higher NEMA Class overload during start (ramp-up) will eliminate nuisance tripping in higher inertia or high friction loads.

The starter's At-Speed detection circuit determines when the motor has reached full speed based on closed loop feedback signals. When the At-Speed condition is reached, the overload trip curve will shift from the Start to the Run level, as programmed in Functions F003 and F004. See Section 5 for programming details.

**TD Series  
Overload Trip Curves**

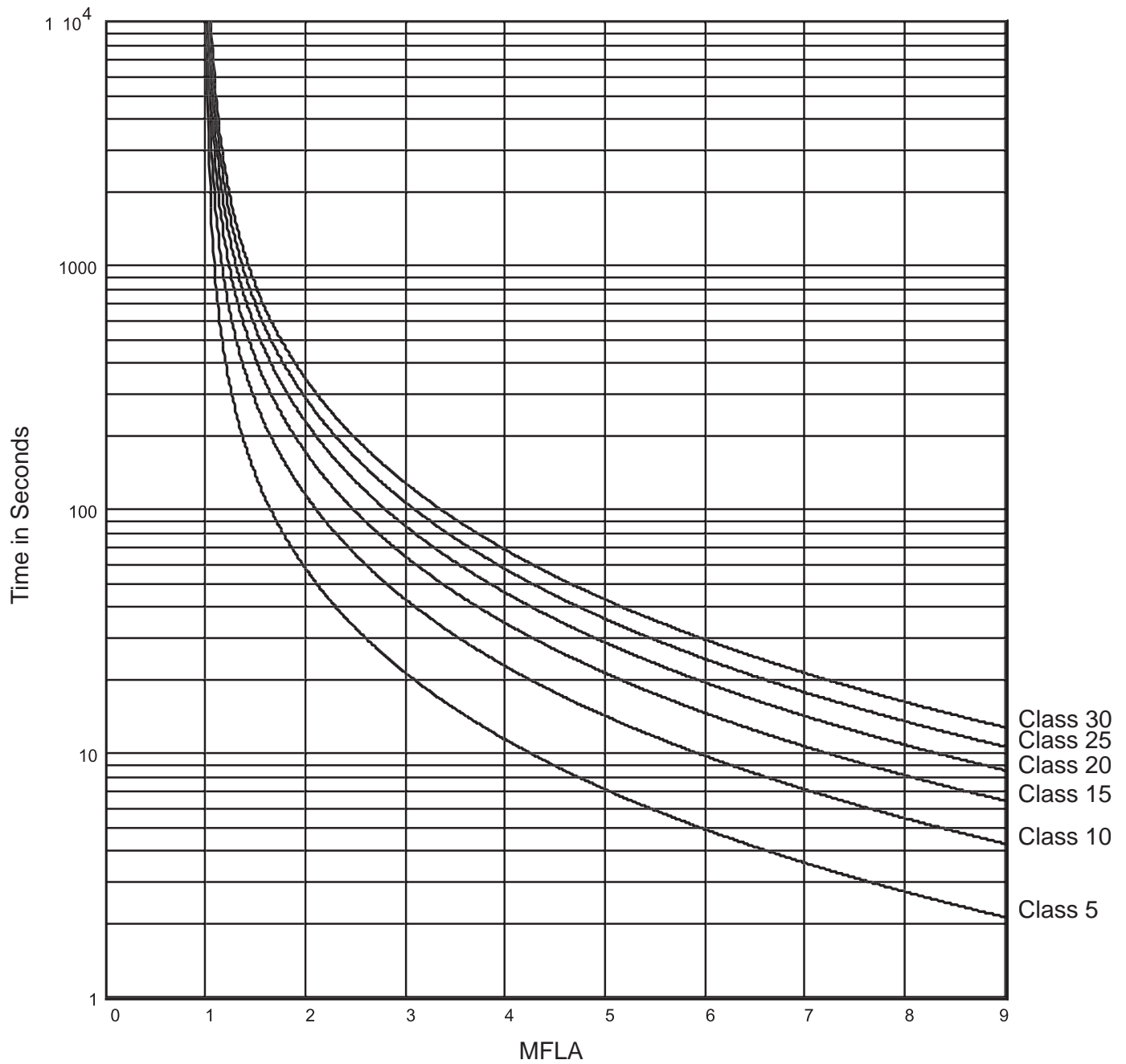

**Note: Factory default setting is Class 10 for both Start and Run Overload Protection**

## Chapter 4 - Connections

### 4.1 Power Connections

Connect appropriate power lines to the unit input terminals marked L1, L2, L3. Avoid routing power wires near the control board. Connect the motor leads to the unit terminals marked T1, T2, T3. Refer to NEC standards for wire length and sizing. Never interchange input and output connections to the unit. This could cause excessive voltage in the control logic circuit and may damage the unit.



**WARNING**

**Never connect power factor correction capacitors on the load side of the unit. The SCRs will be seriously damaged if capacitors are located on the load side.**

The unit cannot be tested without a motor or other test load connected to the load side of the unit. It may be necessary to use a load bank to test the unit without a motor. Note that line voltage will appear across the output terminals if there is no motor or load connected to the unit. In areas where lightning is a significant problem, stationary air gap lightning arrestors should be considered and utilized on the input power source.

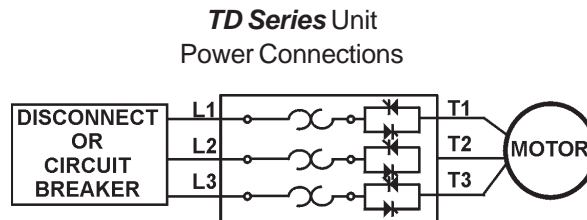

#### 4.1.1 Grounding

Connect the ground cable to the ground terminal as labeled on the unit. Refer to the National Electrical Code for the proper ground wire sizing and be sure that the ground connector is connected to earth ground.

### 4.2 Control Connections

#### 4.2.1 Control Power Connections

Separate 120VAC supply is required (order 240 VAC if required). The control voltage should be connected to pins 1 and 6 of TB1. This control voltage must be customer supplied, unless an optional control power transformer has been supplied with the unit. The terminal block TB1 is located on the main power board. However, on units rated 150 Amps and above, TB1 is brought out to a duplicate terminal block on the back panel assembly.

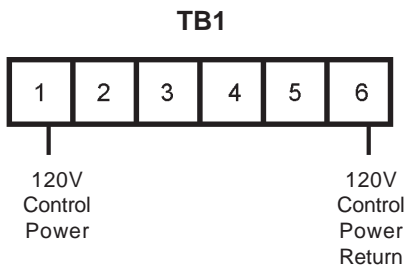

Unit comes standard with 120VAC control. Order 240VAC control as an option if required.

**4.2.2 Three-Wire Connection**

For standard 3-wire control connect 120VAC to pins 1 and 6 of TB1. Connect N.C. (normally closed) stop button between pins 3 and 4 of TB1. Connect N.O. (normally open) start button between pins 4 and 5 of terminal block TB1.

**4.2.3 Two-Wire Connection**

An alternate connection for unattended operation replaces start/stop push buttons

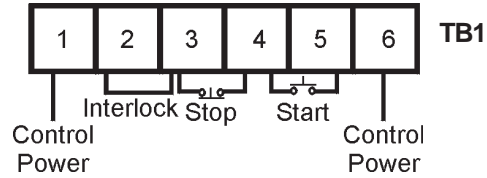

Three-Wire Connection

by connecting a maintained contact closure between pins 3 and 5 on TB1. When the maintained contact is used for start/stop it is necessary to set the overload relay to the manual reset position. This will prevent the motor from restarting if the thermal overload trips and then cools off.



**When two-wire connection method is used, the user's control circuit must be interlocked to prevent automatic restart when protective devices reset. Refer to section 3.1.3.b.**

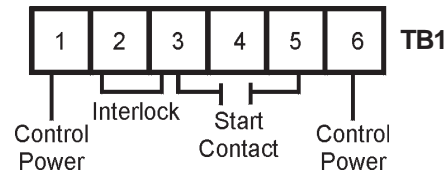

Two-Wire Connection

**4.2.4 Relay Contacts**

All the relay contacts are FORM C common (N.O., N.C.), except the optical triac output. TOSHIBA recommends fusing all contacts with external fuses. TB2 is the terminal block for all auxiliary contacts. Each contact is explained in the following sections. See Chapter 9 for main control board layout.

**4.2.5 Programmable Relays**

Three programmable relays are on TB2 which is located on the main control board. The relays are rated for 240 VAC, 5 A and 1200 VA.

Factory settings for these relays are:

**AUX 1 - Run / Stop (F050 = 1)**

**AUX 2 - At Speed / Stop (F051 = 2)**

**AUX 3 - Any Trip (F052 = 14)**

1			2			3			4			5			6			7			8			9			10			11			12		
C			NO			NC			C			NO			NC			C			NO			NC											
Programmable Relay									Programmable Relay									Programmable Relay									Fault Signal								
AUX 1 Fn F050									AUX 2 Fn F051									AUX 3 Fn F052									Optical Triac Driver 240Vac 50mA								
240Vac / 5A / 1200VA																																			

TB2

#### 4.2.6 Fault Signal

An optical AC switch triac driver is used for fault indication. This signal energizes with the fault LED. The optical output is rated for 240 VAC, 50 mA (maximum).

#### 4.2.7 Resetting Faults

To reset faults, press the RESET key on the keypad.

#### 4.2.8 Enabling the Jog Function

Closing TB4 Pins 1 and 2 will enable the Jog feature. The Jog feature can be used for tasks such as lining up machines for blade or bit changes or inching belts along to check tracking. See chapter 9 for main control board layout.

#### 4.2.9 Enabling the Dual Ramp Feature

Closing TB4 Pins 1 and 3 will enable ramp 2. The dual ramp feature is useful in instances where a load changes such as a loaded or unloaded conveyor belt. The characteristics for starting an unloaded conveyor can be programmed for ramp 1. The characteristics for starting a loaded conveyor can be programmed for ramp 2.

#### 4.3 Interlock Connection

TB1 provides a connection point for an external user N.C. (normally closed) interlock device between pins 2 and 3. (Examples of the use of this interlock connection would be for conditions such as low oil, high temperature, or excess vibration from user supplied devices).

A factory installed jumper is provided which allows the **TD** unit to operate if external interlocks are not used. If this jumper is removed and an interlock is not used, the **TD** unit will not function.

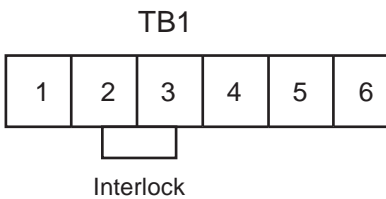
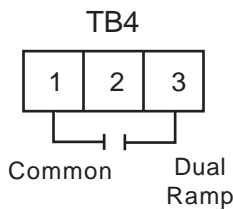
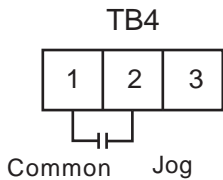

## Chapter 5 - Programming

### 5.1 Introduction

It is best to operate the motor at its full load starting condition to achieve the proper time, torque and ramp settings. Initial factory settings are set to accommodate general motor applications and provide basic motor protection. Advanced features must be enabled via programming. The only parameter that **MUST** be set by the user is motor FLA (F001).

**MOTOR FLA (F001)  
must be programmed  
for unit to operate.**

### 5.2 Digital Interface

The *TD* Soft Starter includes an intuitive, digital keypad with eight LEDs, seven command keys, and an LED display with four alphanumeric digits.



<b>Keys</b>	Reset	Clears the trip indicator and releases the trip relay.
	Fn	Enters or exits the program mode.
	Up Arrow	Navigates through the Status Display Mode, scrolls up through the list of functions, increases the value of an active (flashing) digit, and scrolls through the history of fault conditions.
	Right Arrow	Each keypress shifts the active (flashing) digit to the right one position, use to change function number or value.
	Down Arrow	Navigates through the Status Display Mode, scrolls down through the list of functions, decreases the value of an active (flashing) digit, and scrolls through the history of fault conditions.
	Left Arrow	Each keypress shifts the flashing digit to the left one position, use to change function number or value.
	Read Enter	Selects and stores the value of a function.
<b>Green LEDs</b>	Power On	Control power is present.
	At Speed	Motor is at full speed and power. (The SCRs have phased fully on.)
<b>Yellow LEDs</b>	Shunt Trip	Two or more power poles are shorted and current is passing to the motor while in the off mode. For positive motor protection, an auxiliary relay should be programmed for "Shunt Trip" and should be interlocked with a shunt trip breaker or in-line contactor. (In the event of a shunt trip, do not re-power the unit without repairing the power poles.)
	Shorted SCR	Shorted SCR has been detected in the unit. Refer to section 8.2 for instructions on checking SCRs.
	Over Current	Over Current LED illuminates for two sets of fault conditions: over current and short circuit. If unit experiences output current (of any phase) in excess of the value programmed in F034 (over current trip %) for the time period specified in F035 (over current trip delay), this LED will illuminate and either oCA, oCC, or oCd will be displayed. If unit experiences a short circuit fault condition, the Over Current LED illuminates and either SCA, SCC, or SCd will be displayed. This trip is fixed at 10 times the full load motor current and is not adjustable.
	Phase Loss	One or more of the phase currents is low or has been lost while the motor was starting or running.
	Over Temp	Motor starter has tripped due to heat sink over temperature.
	Over Load	Starter's motor overload has tripped. The overload must be reset before the fault can be cleared
<b>Display</b>	8888	4 digit 7 segment display

### 5.3 Display Modes

There are three modes of display: the Status Display mode, the Program mode, and the Fault mode.

#### 5.3.1 Status Display Mode

The Status Display Mode displays three phase motor current information and the thermal capacity remaining.

Status mode:

- [0000.] The initial display on power up is four digits and the decimal. This indicates the motor current for Phase A of the motor.
- [0000] Scroll up to display four digits only (no decimal). This indicates the motor current for either Phase B or C. While viewing Phase A, press the **UP** arrow once to view Phase B or twice to view Phase C current.
- [H000] Scroll up to display the "H". This indicates that this value is the remaining thermal capacity of the motor (as a percentage i.e. H070 = 70% remaining thermal capacity)

#### Reading Phase Current and Thermal Capacity (See Example)

[0120.] Indicates that Phase A is drawing 120 amps.

Press the **UP** arrow.

[0121] Indicates that Phase B is drawing 121 amps.

Press the **UP** arrow.

**NOTE: Decimal points are not present in the readouts for Phase B and Phase C.**

[0120] Indicates that Phase C is drawing 120 amps.

Press the **UP** arrow.

[H051] Indicates that the motor has 51% of its thermal capacity remaining.

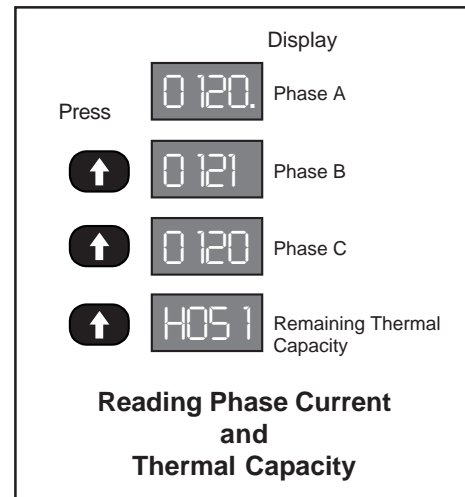

#### 5.3.2 Program Mode

Use the Program Mode to view or change Function (Fn) settings.

To enter the Program Mode, press the [Fn] key once. The first time you enter Program Mode after power has been cycled to the starter, the initial function [F001] should display with the selected digit flashing. If the **TD** Soft Starter has been programmed and power to the unit has not been cycled, the readout will display the last function viewed or changed.

To change to a different function, use the arrow keys.

Program Mode:

- [F001] The "F" indicates the programmable function.
- [0000] This is the present setting of the applicable function. This display may include decimals between digits depending on the function setting's range and incremental step.

**Viewing a Function’s Set Value (See Example)**

**NOTE:** If password protection has been enabled, operator will need to obtain password access before function settings can be changed.

[0000.] Indicates that Phase A is drawing no current.

Press the **Fn** key.

[F001] Indicates that this is (function 001) Motor FLA.

To view the F001’s value, press

**Read Enter.**

[0306] Indicates that the programmed motor FLA is 306 Amps.

Press the **Fn** key to return to the function.

[F001] Press the **Fn** key again to return to the Status Display Mode.

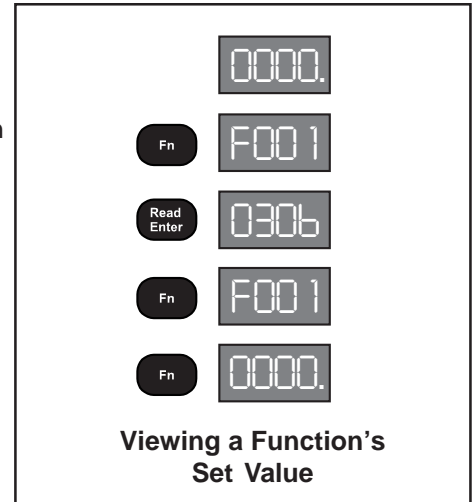

**Enabling Password Protection / Parameter Lock**

The **TD Series** Soft Starter is shipped with the Customer password disabled (F060 = 0). If it is necessary to prevent parameters from being changed inadvertently, set the password in function F060. See Appendix 4 for details.

The display of a customer password is encrypted. If you do not have a record of the password and need to gain access, contact TOSHIBA Tech Support. Be ready to provide the **TD Series** serial number and the four digits in the encrypted display. If the display reads “Err” when the READ/ENTER key is pressed, the parameter lock is enabled.

**Changing a Function’s Set Value**

Use the **UP** arrow key to increment the value of the flashing digit. Use the **DOWN** arrow key to decrement the value of the flashing digit. Use the **LEFT** or **RIGHT** arrow to select the next digit to be altered. Values can only be changed within the Adjustment Range of the function parameter.

**Storing the Altered Value of a Function**

Once the desired value is displayed, press the **READ/ENTER** key. This stores the value in memory. The readout momentarily displays [ END] and then returns to another function code.

**NOTE:** If the Fn key is pressed BEFORE the READ/ENTER key is pressed, the **TD Series** Starter will not store the selected value in memory.

**Setting Motor FLA and Overload Class During Start (See Example)**

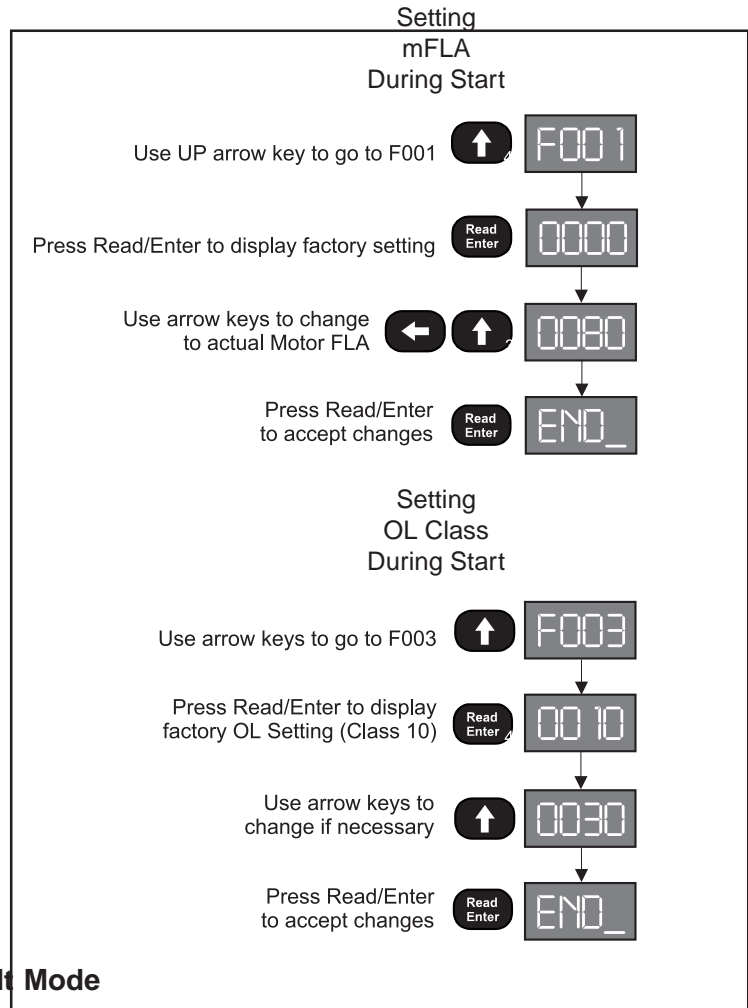

**5.3.3 Fault Mode**

The Fault Display Mode provides information to the operator when a fault occurs or when the operator wishes to review fault history. Refer to Section 7 for details. Fault codes are three-digits in length and are displayed in alpha characters. The first and second characters (reading left to right) are the initials for the applicable English-language fault name. The third or right-most character can be either A, C, or D to denote when the fault occurred. A denotes **A**cceleration. C denotes **C**onstant speed. D denotes **D**ecel.

**Reading Fault Code (See Example)**

[ PLC.] Indicates a Phase Loss fault was detected while at Constant Speed. The decimal point (to the right of the C) denotes that this is the most recent fault condition.

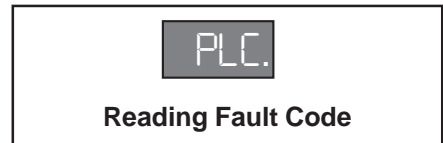

Once a fault condition has been corrected, pressing the **Reset** key will return the readout to the Status Display mode. Fault History can be accessed during a fault condition. While the current fault number is being displayed, use the Up and Down Arrow keys to scroll through the Fault History. Access Fault History via Functions F075 through F083.

## 5.4 The TD Function List

### 5.4.1 Motor FLA, Service Factor and Overload Protection Functions

Fn	Group	Function	Adjustment Range	Setting Increments	Factory Setting	Section
F001	Motor and Overload	Motor Nameplate FLA Motor FLA must be programmed for proper unit operation.	50-100% of starter Max. Amp rating Upper limit of range automatically adjusts downward as Service Factor is increased	1 amp	0 (Starter disabled until set to FLA)	5.5.1
F002		Motor Nameplate Service Factor	1.00 - 1.30	0.05	1.0 SF	5.5.1
F003		Overload Class During Start	5 - 30 NEMA / UL Class Overload Time / Trip Curve	5	Class 10	5.5.1
F004		Overload Class During Run	5 - 30 NEMA / UL Class Overload Time / Trip Curve	5	Class 10	5.5.1
F005		Overload Reset	0=Manual 1=Auto 2=Disabled Overload	1	0 (Manual)	5.5.1
F006-F009		Reserved	Reserved	Reserved	Reserved	Reserved

### 5.4.2 Starting Mode Functions

Fn	Group	Function	Adjustment Range	Setting Increments	Factory Setting	Section
F010	Starting Mode	Ramp Select  VR = Voltage Ramp, CR = Current Ramp	Range is 1 - 4 Setting to #1: Ramp 1 = VR, Ramp 2 = VR Setting to #2: Ramp 1 = CR, Ramp 2 = CR Setting to #3: Ramp 1 = VR, Ramp 2 = CR Setting to #4: Ramp 1 = CR, Ramp 2 = VR	1	1 (VR1-VR2)	5.5.2
F011		Initial Voltage of Ramp 1	0-100%	1%	60%	5.5.2
F012		Initial Current of Ramp 1	0-600% (note1)	1%	200%	5.5.2
F013		Accel Ramp Time of Ramp 1	1-120 seconds	1 second	10 seconds	5.5.2
F014		Max Current Limit of Ramp 1	200 - 600% (note1)	1%	350%	5.5.2
F015		Initial Voltage of Ramp 2	0-100%	1%	60%	5.5.2
F016		Initial Current of Ramp 2	0-600% (note1)	1%	200%	5.5.2
F017		Accel Ramp Time of Ramp 2	1-120 seconds	1 second	10 seconds	5.5.2
F018		Max Current Limit of Ramp 2	200 - 600% (note1)	1%	350%	5.5.2

### 5.4.3 Jog Mode Functions

Fn	Group	Function	Adjustment Range	Setting Increments	Factory Setting	Section
F019	Jog Mode	Voltage Jog	5 - 100%	1%	50%	5.5.3
F020		Time of Voltage Jog	1 - 20 Seconds	1 second	10 seconds	5.5.3
F021		Current Jog	100 - 500%	1%	150%	5.5.3

Note 1: Current percentages are based on Motor Full Load Amps (FLA) as entered in F001.

## 5.4.4 Kick Start Mode Functions

Fn	Group	Function	Adjustment Range	Setting Increments	Factory Setting	Section
F022	Kick Start Mode	Kick Start	0=Disabled 1=Enabled	1	0 (Disabled)	5.5.4
F023		Kick Voltage	10 - 100%	1%	65%	5.5.4
F024		Kick Time	0.1 - 2 Seconds	0.1 second	0.8 seconds	5.5.4

## 5.4.5 Decel Mode Functions

Fn	Group	Function	Adjustment Range	Setting Increments	Factory Setting	Section
F025	Decel Mode	Deceleration Ramp	0=Disabled / Coast to Stop 1=Enabled (except in event of OL Trip) 2=Enabled (continued Decel on OL Trip)	1	0 (Disabled)	5.5.5
F026		Begin Decel Level (BDL)	0 - 100 %	1%	60%	5.5.5
F027		Decel Shut Off Voltage	0 to (BDL minus 1)%	1%	30%	5.5.5
F028		Decel Ramp Time	1 - 60 Seconds	1 second	10 seconds	5.5.5
F029		Reserved	Reserved	Reserved	Reserved	5.5.5

## 5.4.6 Protection Features

Fn	Group	Function	Adjustment Range	Setting Increments	Factory Setting	Section
F030	Protection Features	Current Imbalance Trip	0=Disabled 1=Enabled	1	0 (Disabled)	5.5.6
F031		Current Imbalance Trip %	5 - 30%	1%	10%	5.5.6
F032		Current Imbalance Trip Delay	1 - 20 seconds	1 second	2 seconds	5.5.6
F033		Over Current / Shear Pin Trip	0=Disabled 1=Enabled	1	0 (Disabled)	5.5.6
F034		Over Current / Shear Pin Trip %	50 - 300% (note1)	1%	125%	5.5.6
F035		Over Current Trip Delay	1 - 20 seconds	1 second	1 second	5.5.6
F036		Under Current Trip	0=Disabled 1=Enabled	1	0 (Disabled)	5.5.6
F037		Under Current Trip %	10 - 90% (note1)	1%	40%	5.5.6
F038		Under Current Trip Delay	1 - 60 seconds	1 second	2 seconds	5.5.6
F039		Coast Down Lockout Timer	0=Disabled 1=Enabled	1	0 (Disabled)	5.5.6
F040		Coast Down Lockout Time	1 - 60 minutes	1 minute	5 minutes	5.5.6
F041		Starts per Hour Lockout	0=Disabled 1=Enabled	1	0 (Disabled)	5.5.6
F042		Maximum Starts per Hour	1 - 10	1	2	5.5.6
F043		Time Between Starts Lockout	0=Disabled 1=Enabled	1	0 (Disabled)	5.5.6
F044		Minimum Time Between Starts	1 - 60 minutes	1 minute	15 minutes	5.5.6
F045		Coast Down Timer Value	1 - 3600 Seconds	View Only	0	5.5.6
F046		Starts per Hour Timer Value	1 - 3600 Seconds	View Only	0	5.5.6
F047		Starts per Hour Count Value	1 - 10 Starts	View Only	0	5.5.6
F048		Time Value Between Starts	1 - 3600 Seconds	View Only	0	5.5.6
F049	Thermal Capacity to Start	0 - 100 % Thermal Capacity	View Only	0	5.5.6	

## 5.4.7 Relays

Fn	Group	Function	Adjustment Range	Setting Increments	Factory Setting	Section
F050	Relays	Aux Relay 1 setting	Operation # 1 - 18 (note2)	1	1	5.5.7
F051		Aux Relay 2 setting	Operation # 1 - 18	1	2	5.5.7
F052		Aux Relay 3 setting	Operation # 1 - 18	1	14	5.5.7
F053- F054		Reserved	Reserved	Reserved	Reserved	5.5.7

Note 2: Auxiliary relays can be programmed for any of the following operations.

# 1 - Run / Stop (Signal)	# 7 - Shunt Trip	# 13 - Under Current Trip
# 2 - At Speed / Stop (Signal)	# 8 - OL Trip	# 14 - Any Trip (# 5 - #13)
# 3 - At Speed / End of Decel (SCRs Off)	# 9 - OT Trip	# 15 - Cooldown Time
# 4 - Start / End of Decel	# 10 - Short Circuit Trip	# 16 - Starts Per Hour
# 5 - Short SCR Trip	# 11 - Current Imbalance Trip	# 17 - Time Between Starts
# 6 - Phase Loss Trip	# 12 - Over Current Trip	# 18 - Any Lockout (#15 -17)

## 5.4.8 Communications

Fn	Group	Function	Adjustment Range	Setting Increments	Factory Setting	Section
F055	Communications	Communications	0=Disabled 1=Enabled	1	0	5.5.8
F056		Baud Rate	9.6 - 38.4 KB	9.6 KB	9.6 KB	5.5.8
F057		Modbus Address	1 - 247	1	1	5.5.8
F058- F059		Reserved	Reserved	Reserved	Reserved	5.5.8

## 5.4.9 System Settings

Fn	Group	Function	Adjustment Range	Setting Increments	Factory Setting	Section
F060	System Settings	Parameter Lock/ User Password	Range is 0 - 999 0 = Disabled Any Other Number = Password Protected	1	0 (Disabled)	5.5.9
F061		Reset Factory Default Settings	Range is 0 - 2 0=Disabled 1=Clear Thermal Register and Lockout Timers 2 = Reset to Factory Default Settings	1	0	5.5.9
F062- F064		Reserved	Reserved	Reserved	Reserved	5.5.9
F065		Year	2000 - 2047	1 Year	Date of Mfg.	5.5.9
F066		Month	1 - 12	1 Month	Date of Mfg.	5.5.9
F067		Day	1 - 31	1 Day	Date of Mfg.	5.5.9
F068		Hour	0 - 23	1 Hour	Date of Mfg.	5.5.9
F069		Minute	0 - 59	1 Minute	Date of Mfg.	5.5.9
F070		Second	0 - 59	1 Second	Date of Mfg.	5.5.9
F071		Revision #	-	View Only	Factory Setting	5.5.9
F072- F074		Reserved	Reserved	Reserved	Reserved	5.5.9

## 5.4.10 Fault History and Run Time

Fn	Group	Function	Adjustment Range	Setting Increments	Factory Setting	Section
F075	Fault History and Run Time	Fault History #1, Latest Fault	0, 1 - 27 (Fault #: see Fault code list; 0: No fault history)	View Only	0	5.5.10
F076		Time Stamp, Fault #1	00.00-23.59 (hh.mm) [hh = 00-23; mm = 00-59]	View Only	00.00 EST	5.5.10
F077		Date Stamp, Fault #1	01.01 - 12.31 (MM.DD) [MM = 01-12; DD = 01-31]	View Only	01.01	5.5.10
F078		Fault History #2, Previous Fault	0, 1 - 27 (Fault #: see Fault code list; 0: No fault history)	View Only	0	5.5.10
F079		Time Stamp, Fault #2	00.00-23.59 (hh.mm) [hh = 00-23; mm = 00-59]	View Only	00.00 EST	5.5.10
F080		Date Stamp, Fault #2	01.01 - 12.31 (MM.DD) [MM = 01-12; DD = 01-31]	View Only	01.01	5.5.10
F081		Fault History #3, Oldest Fault	0, 1 - 27 (Fault #: see Fault code list; 0: No fault history)	View Only	0	5.5.10
F082		Time Stamp, Fault #3	00.00-23.59 (hh.mm) [hh = 00-23; mm = 00-59]	View Only	00.00 EST	5.5.10
F083		Date Stamp, Fault #3	01.01 - 12.31 (MM.DD) [MM = 01-12; DD = 01-31]	View Only	01.01	5.5.10
F084		Run Time, Hours	000.0 - 999.9 (hours)	View Only	0	5.5.10
F085		Run Time, K Hours	0000 - 9999 (thousand hours)	View Only	0	5.5.10
F086		Run Counts	0000 - 9999 (times)	View Only	0	5.5.10
F087		Run Counts, 10K times	0000 - 9999 (10 thousand times)	View Only	0	5.5.10

## 5.5 Function Descriptions

The unit is set at the factory with typical starting characteristics that perform well in most applications.

**Note:** Customer must program motor FLA (F001) for unit to operate.

## 5.5.1 Motor and Overload Function Descriptions

**F001 = Motor FLA**

**Factory Setting = 0**

**Range = 50 - 100% of Unit Max. Current.**

Set the value of this function to the motor nameplate Full Load Amps (FLA). Adjustments for service factor are not necessary when programming this function. (See note below). If the motor nameplate FLA is not available, use typical values as shown in NEC, NEMA standard MG-1 or other reputable third party source (motor manufacturer, etc.).

**Note:** To prevent adjusting the settings beyond the starter Max Amp rating, the range of adjustment for the Motor Nameplate FLA will vary to reflect the Service Factor as programmed into F002. At the default setting of 1.0SF, the full range of adjustment from 50 - 100% of the Max Amp rating is available. For example F002 = 1.15 to reflect a 1.15SF, the maximum FLA programmable into F001 will be limited to 85% of the starter Max. Amp rating (100% - 15%).

**F002 = Service Factor****Factory Setting = 1.0 S.F.****Range = 1.00 - 1.30**

Set value according to the Service Factor (SF) data provided on the motor's nameplate. This value affects several protection features so it must be accurate. Setting the SF too high may result in motor damage in overload conditions. Setting SF too low may cause nuisance trips.

**F003 = Overload Class During Start****Factory Setting = 10 (Class 10)****Range = 5 - 30 NEMA / UL Class**

Set value to the motor protection overload class required for the application. It is recommended that you try the factory setting first. (If possible, keep values for F003 and F004 the same.) Increase F003 above F004 only if nuisance tripping occurs during start. See Section 3.2 for details on trip curves.

**F004 = Overload Class During Run****Factory Setting = 10 (Class 10)****Range = 5 - 30 NEMA / UL Class**

Set value according to the instructions provided by your motor / equipment manufacturer. This trip curve will not be enabled until the motor has reached full speed.

**F005 = Overload Reset****Factory Setting = 0 (Manual)****Range = 0 - 2**

Set value to determine starter behavior after an overload condition has cleared.

When set to **0 = Manual**, the operator must press the **Reset** key before restarting the motor. Once the motor windings have cooled sufficiently **AND** the **Reset** key is pressed, the unit will accept a restart command.

When set to **1 = Automatic** mode, and once sufficient time has elapsed allowing motor windings to cool, the motor will be restarted upon a start command.

**WARNING**

**Setting F005 = 1 (Automatic) may present significant operational risk.**

When set to **2 = Disabled Overload**, a separate external thermal overload protection device must be in the circuit.

**F006 - F009 = Reserved**

### 5.5.2 Starting Mode

The **TD** is capable of several different starting modes, but is set from the factory for the most common applications. A second ramp profile is available for use should you need it but unless wired to do so, the **TD** defaults to Ramp 1. This section describes functions for Ramp 1, with references to function numbers that do the same thing for Ramp 2 if required. Refer to Appendix 2 for a detailed description of the differences in Ramp Profiles and their uses.

#### F010 = Ramp Profile Selection

**Factory Setting = 1**

**Range = 1 - 4**

This Function selects the type of Ramp Profile desired. Ramp profiles can be either Voltage Ramp or Current Ramp. See Appendix 2 for details. Each Ramp Profile consists of 3 settings:

Initial Torque, Ramp Time and Maximum Current Limit

Because there are two ramps available, there are 4 settings to cover the combinations of profiles possible. If you are not using the 2nd ramp, the TD will ignore all settings in reference to Ramp 2.

Select Voltage Ramp by setting **F010 = 1** (factory default)

When Voltage Ramp is selected,

Set Initial Torque with **F011** (see below)

Set Ramp with **F013** (see below)

Set Maximum Current Limit with **F014** (see below)

Or;

Select Current Ramp by setting **F010 = 2**

When Current Ramp is selected,

Set Initial Torque with **F012** (see below)

Set Ramp Time with **F013** (see below)

Set Maximum Current Limit with **F014** (see below)

F010 Ramp Profile Selection	Setting	Ramp Type	
		Ramp 1	Ramp 2
	1	Voltage Ramp	Voltage Ramp
	2	Current Ramp	Current Ramp
	3	Voltage Ramp	Current Ramp
	4	Current Ramp	Voltage Ramp

#### F011 = Initial Voltage of Ramp 1

**Factory Setting = 60%**

**Range = 0 - 100%**

Sets the initial voltage of ramp 1 when **F010 = 1 or 3**. The initial torque level should be set to provide just enough torque to make the motor shaft begin to rotate while preventing torque shock damage to mechanical components.

#### F012 = Initial Current of Ramp 1

**Factory Setting = 200%**

**Range = 0 - 600%**

Sets the initial current of ramp 1 (when **F010 = 2 or 4**). Current percentages are based on the Motor FLA as set in F001. The initial torque level should be set to provide just enough torque to make the motor shaft begin to rotate while preventing torque shock damage to mechanical components.

**F013 = Accel Ramp Time of Ramp 1**  
**Factory Setting = 10 seconds**  
**Range = 1 - 120 seconds**

Sets the time between the initial torque (set with F011 or F012) and either the Max Current Limit (set with F014) or full output voltage. Set time to enable soft starts without stalls. Also consider your motor's application. For example, centrifugal pumps may require a shorter ramp time.

Note: Ramp time is affected by the following conditions:

1. Current limit will extend the ramp time if the motor does not reach full speed while in current limit mode.
2. Anti-oscillation circuit will shorten the ramp time if the motor reaches full speed before end of ramp.

**F014 = Max Current Limit of Ramp 1**  
**Factory Setting = 350%**  
**Range = 200 - 600%**

Sets the maximum motor current that the **TD** Starter will allow during ramp 1. This limit applies to both voltage and current-type ramping.

Current will be limited to this setting until either the motor reaches full speed or the over load protection feature trips (F003). Current percentages are based on the Motor FLA as programmed in F001. Once the motor has reached full speed, the current limit feature is inactive.

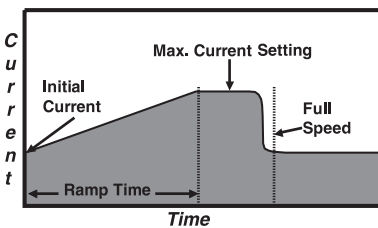

**For Ramp 2 (user-optional ramp)**

This ramp is selected by closing the input on Terminals TB4 - Pins 1 and 3. If this input is left open, the **TD** will respond only to ramp 1 settings as listed above. Since ramp 2 is always used in combination with ramp 1, different combinations of ramp profiles can be selected in F010. Refer to Appendix 1 for additional information.

**F015 = Initial Voltage of Ramp 2**  
**Factory Setting = 60%**  
**Range = 0 - 100%**

Sets the initial voltage of ramp 2 when F010 = 1 or 4. The initial torque level should be set to provide just enough torque to make the motor shaft begin to rotate while preventing torque shock damage to mechanical components.

**F016 = Initial Current of Ramp 2**  
**Factory Setting = 200%**  
**Range = 0 - 600%**

Sets the initial current of ramp 2 when F010 = 2 or 3. Current percentages are based on the Motor FLA as programmed in F001. The initial torque level should be set to provide just enough torque to make the motor shaft begin to rotate while preventing torque shock damage to mechanical components.

**F017 = Accel Ramp Time of Ramp 2**  
**Factory Setting = 10 seconds**  
**Range = 1 - 120 seconds**

Sets the time between the initial torque (set with F015 or F016) and either the Max Current Limit (set with F014) or full output voltage. Set time to enable soft starts without stalls. Also consider your motor's application. For example, centrifugal pumps may require a shorter time. See notes under F013 for more details.

**F018 = Max Current Limit of Ramp 2**  
**Factory Setting = 350%**  
**Range = 200 - 600%**

Sets the maximum motor current that the **TD** Starter will allow during ramp 2. (This limit applies to both voltage and current-type ramping.)

Current will be limited to this setting until either the motor reaches full speed or the over load protection feature trips (F003). Current percentages are based on the Motor FLA as programmed in F001. Once the motor has reached full speed, the current limit feature is inactive.

**CAUTION**

**Section 5.5.3 Jog Mode**

**Continuous use of the Jog feature — either the voltage type (F019) or the current type (F021) — risks thermal motor damage or nuisance tripping.**

The Jog Function is another user optional feature and is controlled by closing the input on TB4 Pins 1 and 2. If this input is left open, the **TD** will ignore all Jog settings. The Jog feature provides an output from the SCRs only while this input is closed. It will not continue ramping to full acceleration. This feature can Jog the motor at either a preset Voltage or a preset Current.

Selection of either Voltage or Current Jogging follows the selected Ramp Profile. The Jog mode is determined then by F010 above, and whether you have selected ramp 1 or ramp 2. See the table below for Function numbers relating to the Jog Function in each Ramp Profile.

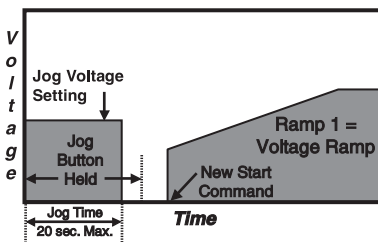

**Voltage Jog**

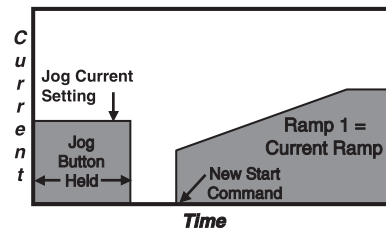

**Current Jog**

F010 Setting	Dual Ramp Input Open			Dual Ramp Input Closed		
	Ramp 1 and Jog Type	Ramp 1 Initial Torque	Jog Torque Reference	Ramp 2 and Jog Type	Ramp 2 Initial Torque	Jog Torque Reference
1	Voltage	F011	F019	Voltage	F015	F019
2	Current	F012	F021	Current	F016	F021
3	Voltage	F011	F019	Current	F016	F021
4	Current	F012	F021	Voltage	F015	F019

**F019 = Voltage Jog**  
**Factory Setting = 50%**  
**Range = 5 - 100%**

Sets the voltage level of the Jog feature typically is used to check rotation, alignment, or to slowly move a load into position. Jogging at a set voltage has no current control so the duration of the applied voltage must be limited to prevent excessive motor heating.

**F020 = Time of Voltage Jog**  
**Factory Setting = 10 seconds**  
**Range = 1 - 20 seconds**

Set to minimize motor heating during a voltage jog. This setting is the maximum allowable time for jogging the motor.

**F021 = Current Jog**  
**Factory Setting = 150%**  
**Range = 100 - 500%**

Sets output of a current Jog. The jog feature is typically used to check rotation, alignment, or slowly move a load into position.

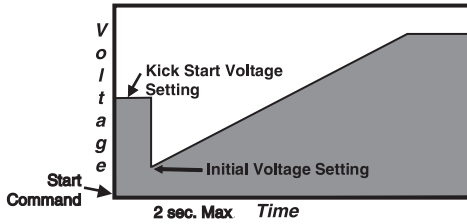

Kick Start

### 5.5.4 Kick Start Mode

**Note:** Do not use the Kick Start feature unless you determine that you need it. Using this feature may eliminate many of the mechanical and electrical benefits of using a Soft Starter.

**F022 = Kick Start**  
**Factory Setting = 0 (Disabled)**  
**Range = 0 - 1**

Kick start applies a “pulse” of voltage to the motor to produce a momentary “kick” of high torque to break the motor load free from high friction or frozen components. When **F022 = 1**, this voltage “pulse” begins the initial voltage applied in either F011 or F015. Voltage level is adjusted by F023 and the time duration of the pulse is adjusted by F024.

**F023 = Kick Voltage**  
**Factory Setting = 65%**  
**Range = 10 - 100%**

Sets the voltage level of the Kick Start feature. The setting of F023 should be higher than F011 and F015 and high enough to provide a benefit in the worst starting condition.

**F024 = Kick Time**  
**Factory Setting = 0.8 seconds**  
**Range = 0.1 - 2 seconds**

Sets the duration of time the Kick Start voltage is applied.

### 5.5.5 Decel Mode

Deceleration is a feature of the **TD** Soft Starter which slowly decreases the applied voltage to the motor when a stop command is given resulting in a gentle decrease in motor torque. Deceleration provides a way to extend the stopping time so that abrupt stopping does not occur. Deceleration is useful with centrifugal pumps, material handlers, and conveyors where abrupt stopping could be damaging to the equipment and/or load

**Note:** Decel is **THE OPPOSITE** of braking. Enabling the Decel feature will make the motor take **LONGER** to stop than if it were simply turned off.

See Appendix 2 at the end of this manual for detailed descriptions of typical applications for the Decel feature.

**F025 = Deceleration Ramp**  
**Factory Setting = 0 (Disabled)**  
**Range = 0 - 2**

When **F025 = 0**, the deceleration feature is disabled.

When **F025 = 1**, the deceleration feature is enabled AND the overload protection feature, set with F003 and F004, is enabled. Even when the stop command is received, the starter continues to apply decel voltage. However, if an overload trip occurs, the starter stops applying voltage and the motor coasts to a stop to prevent additional motor heating and potential motor damage.

When **F025 = 2**, the deceleration feature is enabled and deceleration will continue even when an overload condition trips.



**Setting F025 = 2 presents significant risk of over-heating the motor beyond its design limits which could result in motor damage and fire hazard. Do this only in circumstances where the potential for mechanical damage outweighs the risk of motor damage.**

- F026 = Begin Decel Level (BDL)**  
**Factory Setting = 60%**  
**Range = 0 - 100% of line voltage**  
 Use to drop voltage to a level where there is a noticeable effect on motor torque during decel mode.
- F027 = Decel Shut Off Voltage**  
**Factory Setting = 30%**  
**Range = 0 to (BDL -1)%**  
 Sets the level where motor torque during decel is no longer effective. Always set this function lower than the setting of F026, Begin Decel Level.
- F028 = Decel Ramp Time**  
**Factory Setting = 10 seconds**  
**Range = 1 - 60 seconds**  
 Sets the maximum time for the deceleration ramp to go from the Begin Decel Level setting (F026) to the Decel Shut Off Voltage (F027). Since motor heating increases as voltage is lowered, the setting should not exceed the time necessary to achieve the deceleration effect.
- F029 = Reserved**

**5.5.6 Protection Features**

- F030 = Current Imbalance Trip**  
**Factory Setting = 0 (Disabled)**  
**Range = 0 - 1**  
 If F030 = 1 (Enabled), starter will trip when the output current between any two phases exceeds the amount set with F031 for the time specified with F032.
- F031 = Current Imbalance Trip %**  
**Factory Setting = 10%**  
**Range = 5 - 30%**  
 Use to set the trip level for current imbalance between any two phases. Percentage is based on FLA (F001 setting).
- F032 = Current Imbalance Trip Delay**  
**Factory Setting = 2 seconds**  
**Range = 1 - 20 seconds**  
 Provides a time delay to prevent nuisance trips from short-duration transients. Using default settings, if the difference in output current between two phases exceeds 10% of FLA for more than 2 seconds, the starter will trip.
- F033 = Over Current / Shear Pin Trip**  
**Factory Setting = 0 (Disabled)**  
**Range = 0 - 1**  
 If F033 = 1 (Enabled), starter will trip when the output current of any phase exceeds the amount set with F034 for the time specified with F035. Can be referred to as a "Shear Pin Trip" and can be used to protect mechanical components from breaking due to jammed loads.
- F034 = Over Current Trip %**  
**Factory Setting = 125%**  
**Range = 100 - 300%**  
 Use to set the trip level for an over current condition for any phase. Percentage is based on FLA (F001 setting).

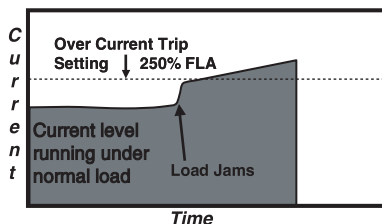

**Over Current Trip (F033 = 1)**

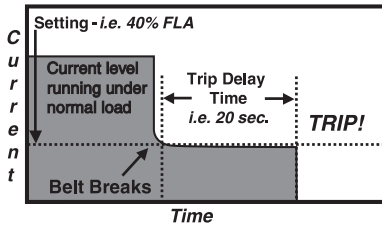

**Under Current Trip  
(F036 = 1)**

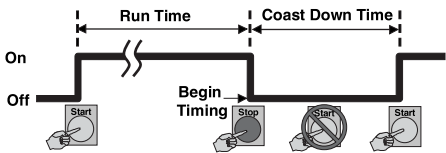

**Coast Down / Backspin Lockout**

**F035 = Over Current Trip delay**  
**Factory Setting = 1 second**  
**Range = 1 - 20 seconds**

Provides a time delay to prevent nuisance trips from short-duration transients. Using default settings, if the output current of any phase exceeds 125% of FLA for more than 1 second, the starter will trip.

**F036 = Under Current Trip**  
**Factory Setting = 0 (Disabled)**  
**Range = 0 - 1**

If F036 = 1 (Enabled), starter will trip when the output current of any phase drops below the amount set with F037 for the time specified with F038. Fault condition is often referred to as a "Load Loss Trip" and can be used to detect a broken drive shaft or belt. In pumping applications, this can be used as a "Loss of Prime" trip.

**F037 = Under Current %**  
**Factory Setting = 40%**  
**Range = 10 - 90%**

Use to set the trip level for an under current condition for any phase. Percentage is based on FLA (F001 setting).

**F038 = Under Current Trip Delay**  
**Factory Setting = 2 seconds**  
**Range = 1 - 60 seconds**

Provides a time delay to prevent nuisance trips from short-duration transients. Using default settings, if the output current of any phase drops below 40% of FLA for more than 2 seconds, the starter will trip.

**F039 = Coast Down Lockout Timer (Back Spin Timer)**  
**Factory Setting = 0 (Disabled)**  
**Range = 0 - 1**

When F039 = 1, this function provides a timer which prevents motor restarts for the number of minutes specified in F040. This function is useful in applications like pump motor backspin - (where you need to prevent the pump motor from restarting if it is spinning backwards).

**F040 = Coast Down Lockout Time**  
**Factory Setting = 5 minutes**  
**Range = 0 - 60 minutes**

Sets a minimum amount of time that a starter must be off before a restart can be completed. (Used in conjunction with F039).

**F041 = Starts per Hour Lockout**  
**Factory Setting = 0 (Disabled)**  
**Range = 0 - 1**

If F041=1, this feature will count the number of start commands within a 1 hour period. If the setting of F042 (maximum starts per hour) is exceeded, starting is prohibited until sufficient time has expired.

**F042 = Maximum Starts per Hour**  
**Factory Setting = 2**  
**Range = 1 - 10**

Consult the motor manufacturer for a "Starts-per-Hour" or "Starting Duty Cycle" rating. Larger motors tend to have lower starts-per-hour ratings. (Used in conjunction with F041).

**Note:** When using the Decel function (F025) or an electronic braking option, count these cycles as additional "starts" when determining maximum starts-per-hour.

**F043 = Time Between Starts Lockout**  
**Factory Setting = 0 (Disabled)**  
**Range = 0 - 1**

If F043= 1, the motor cannot be started within the time specified in F044. Time between starts is calculated from the time of the first start command to the next regardless of run time. (Used in conjunction with F041).

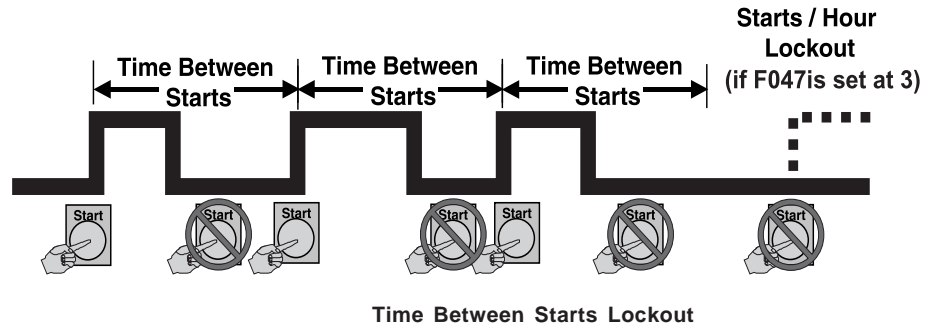

**F044 = Minimum Time Between Starts**  
**Factory Setting = 15 minutes**  
**Range = 1 - 60 minutes**

If F043 = 1 and F044 = 15, motor will not start within 15 minutes of first start.

**F045 = Coast Down Timer Value**  
**Factory Setting = Not Applicable**  
**Range = 1 - 3600 Seconds**

Display for information only; value cannot be altered by the user. Readout only for user's viewing of remaining time value of the Coast Down Lockout Timer.

**F046 = Starts per Hour Timer Value**  
**Factory Setting = Not Applicable**  
**Range = 1 - 3600 Seconds**

Display for information only; value cannot be altered by the user.

Readout only for user's viewing of remaining time value of Starts-per-Hour Lockout Timer.

**F047 = Starts per Hour**  
**Factory Setting = Not Applicable**  
**Range = 1 - 10 Starts**

Display for information only; value cannot be altered by the user.

Readout only for user's viewing of the accumulated Starts-per-Hour value used in the Lockout function.

**F048 = Time Value Between Starts**  
**Factory Setting = Not Applicable**  
**Range = 1 - 3600 Seconds**

Display for information only; value cannot be altered by the user.

Readout only for user's viewing of remaining time value of Minimum Time Between Starts Timer.

**F049 = Thermal Capacity to Start**

**Factory Setting = Not Applicable**

**Range = 0 - 100 % Thermal Capacity**

Display for information only; value cannot be altered by the user.

Readout only for user's viewing of the motor Thermal Capacity percentage required to allow a Reset after an Overload Trip. Use this function in conjunction with the Remaining Thermal Capacity to be able to predict when a restart will be allowed. This value is automatically updated by the **TD** whenever a successful start sequence has been accomplished. The **TD** essentially "learns" how much Thermal Capacity is needed in the motor in order to successfully restart, and stores the information at this Function.

**5.5.7 Relays**

There are three programmable relays (rated 240VAC, 5A, 1200 VA) on the **TD Series**. They can be programmed for change of state indication for any one of the 18 conditions identified in the chart to the left.

Setting	Programmable Relay Setting Descriptions
1	Run / Stop
2	At Speed / Stop
3	At Speed / End of Decel
4	Start / End of Decel
5	Short SCR Trip
6	Phase Loss Trip
7	Shunt Trip
8	Over Load Trip
9	Over Temperature Trip
10	Short Circuit Trip
11	Current Imbalance Trip
12	Over Current Trip
13	Under Current Trip
14	Any Trip (5 - 13)
15	Coastdown Time
16	Starts Per Hour
17	Time Between Starts
18	Any Lockout (15 - 17)

**F050 = Aux Relay 1**

**Factory Setting = 1 (Run / Stop)**

**Range = 1 - 18 (See list.)**

Use to program the desired operation for Relay # 1.

**F051 = Aux Relay 2**

**Factory Setting = 2 (At Speed / Stop)**

**Range = 1 - 18 (See list.)**

Use to program the desired operation for Relay # 2.

**F052 = Aux Relay 3**

**Factory Setting = 14 (Any Trip)**

**Range = 1 - 18 (See list.)**

Use to program the desired operation for Relay # 3.

**F053 - F054 = Reserved**

**5.5.8 Communications**

The **TD** Soft Starter features built-in serial communications via RS-485 hardware and Modbus RTU protocol software. The **TD** Soft Starter is a "passive" communication device which responds and/or replies to the commands of "active" host devices such as personal computers, SCADA systems, PLCs with ASCII ports, DCS and other industrial systems.

**F055 = Communications**

**Factory Setting = 0 (Disabled)**

**Range = 0 - 1**

When F055 = 1, the **TD** Soft Starter will communicate with remote monitoring and control systems.

**F056 = Baud Rate**

**Factory Setting = 9.6 KB**

**Range = 9.6 to 38.4 KB**

Set value to either 9.6 KB, 19.2 KB or 38.4 KB and match the setting of the host device.

**F057 = Modbus Address**

**Factory Setting = 1**

**Range = 1 - 247**

The Modbus communications protocol allows each node to have up to 247 connected devices but each must have a unique address. Two devices with the same address will result in a communications error.

**F058 - F059 = Reserved**

### 5.5.9 System Settings

#### F060 = Parameter Lock / User Password

**Factory Setting = 0 (disabled)**

**Range = 0 - 999**

Provides users with the ability to prevent unauthorized operators from making changes to the programmed functions. ***If you do not need to take advantage of this feature, do not enter anything into this function.*** The factory default is disabled, and no Password is necessary to make changes to the program.

See Appendix 3 at the end of this manual for detailed instructions on using and altering the Parameter Lock / User Password feature.

#### F061 = Emergency Clear / Reset

**Factory Setting = 0 (disabled)**

**Range = 0 - 2**

This Function serves two purposes. It can clear the memory values used for lockouts and overload protection, and it can reset all functions to the factory default settings.

When **F061 = 0**, the feature is disabled. This is a “One-Shot” feature, so when another value is entered as shown below, this function automatically returns to the default state.

When **F061 = 1**, the values stored in the Thermal Register and all of the Lockout Timers will be cleared. This will allow an emergency restart without having to wait for proper cool down time or lockout timers to expire.



**Clearing the Thermal Register to allow restarting without proper cool-down time after an Overload Trip will risk motor damage and fire. Use only where emergency restart is necessary without regard to these potential hazards.**

When **F061 = 2**, the values of all functions will be reset to the factory default settings. Use this feature when settings conflict or have been tampered with. This is also useful when you lose track of experimental settings and wish to start over.

**Note: This will not reset F060 = Parameter Lock / User Password.**

**F062 = Reserved**

**F063 = Reserved for Factory Use**

**F064 = Reserved for Factory Use**

#### 5.5.9.a Real Time Clock Settings

Functions F065 through F070 set the system real time clock. The time clock is primarily used in date/time stamping Fault History. Time clock automatically adjusts for leap years. **Time clock does not automatically adjust for daylight savings time.**

**F065 = Year**

**Factory Setting = Year of manufacture**

**Range = 2000 to 2047**

**F066 = Month**

**Factory Setting = Month of manufacture**

**Range = 1 - 12**

- F067 = Day**  
**Factory Setting = Day of manufacture**  
**Range = 1 - 31**
- F068 = Hour**  
**Factory Setting = Actual (EST)**  
**Range = 0 - 23 (12:00 midnight is hour 0)**
- F069 = Minute**  
**Factory Setting = Actual (EST)**  
**Range = 0 - 59**
- F070 = Second**  
**Factory Setting = Actual (EST)**  
**Range = 0 - 59**
- F071 = Reserved for Factory Use**
- F072 -F074 = Reserved**

### 5.5.10 Fault History and Run Time

The fault history will store the three last fault conditions plus the date and time that each fault occurred.

- F075 = Fault History # 1, Latest Fault**  
**Factory Setting = 0000**  
**Range = NA**  
 Displays 2-digit fault number. See Chapter 7.
- F076 = Time Stamp, Fault # 1**  
**Factory Setting = 00.00**  
**Range = HH.MM where HH = 00 - 23 and MM = 00 - 59**  
 Displays time fault in F075 was detected.
- F077 = Date Stamp, Fault # 1**  
**Factory Setting = 01.01**  
**Range = MM.DD where MM = 01 - 12 and DD = 01 - 31**  
 Displays date time fault in F075 was detected.
- F078 = Fault History # 2, Previous Fault**  
**Factory Setting = 0000**  
**Range = NA**  
 Displays 2-digit fault number. See Chapter 7.
- F079 = Time Stamp, Fault # 2**  
**Factory Setting = 00.00**  
**Range = HH.MM where HH = 00 - 23 and MM = 00 - 59**  
 Displays time fault in F078 was detected.
- F080 = Date Stamp, Fault # 2**  
**Factory Setting = 01.01**  
**Range = MM.DD where MM = 01 - 12 and DD = 01 - 31**  
 Displays date time fault in F078 was detected.
- F081 = Fault History # 3, Oldest Fault**  
**Factory Setting = 0000**  
**Range = NA**  
 Displays 2-digit fault number. See Chapter 7.
- F082 = Time Stamp, Fault # 3**  
**Factory Setting = 00.00**  
**Range = HH.MM where HH = 00 - 23 and MM = 00 - 59**  
 Displays time fault in F081 was detected.

**F083 = Date Stamp, Fault # 3**  
**Factory Setting = 01.01**  
**Range = MM.DD where MM = 01 - 12 and DD = 01 - 31**  
Displays date time fault in F081 was detected.

Functions F084 through F087 display information from the Run Time / Elapsed Time meter and Run-Cycle counter. Run time includes Accel, Run, Decel, and Jog operations.

**F084 = Run Time, Hours**  
**Factory Setting = 0000**  
**Range = 000.9 - 999.9 hours**  
Run counts in excess of 999.9 are recorded in F085.

**F085 = Run Time, K Hours**  
**Factory Setting = 0000**  
**Range = 0000 - 9999 K hours**  
0001 in readout means a run time of 1,000 hours.

**F086 = Run Counts**  
**Factory Setting = 0000**  
**Range = 0000 - 9999**  
Run counts in excess of 9999 are recorded in F087.

**F087 = Run Counts, 10K Times**  
**Factory Setting = 0000**  
**Range = 0000 - 9999, 10 thousand times**  
0001 in readout means a run count of 10,000 operations.

## Chapter 6 - Start-up

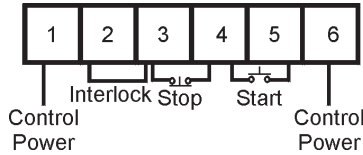

TB1 Three-Wire Connection

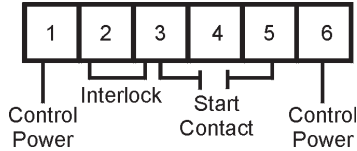

TB1 Two-Wire Connection  
(alternate connection)

**MOTOR FLA (F001)  
must be programmed  
for unit to operate.**

(See page 20 for more information)

### 6.1 Quick Start

Your new **TD Series** Soft Starter is factory preset for a wide variety of applications and often can be used with minimal adjustment.

#### 6.1.1. Three Step Process

1. Connect L1, L2, and L3 to power lines and T1, T2, and T3 to motor.
2. Connect control wires and control power.
3. Program motor FLA (F001).

#### 6.1.2 TD Start-up Parameters and Factory Defaults

Try the initial presets first and then adjust or enable the more advanced features to meet your specific starting needs.

Function Number	Function Name	Factory Setting	Description
F001	Motor Nameplate FLA	0	Starter disabled Unit must be set to actual motor FLA
F002	Motor Service Factor	1.0	Motor Service Factor from motor nameplate
F003	Overload Protection During Start	10	NEMA Overload Class (Class 10)
F004	Overload Protection During Run	10	NEMA Overload Class (Class 10)
F005	Overload Reset	0	Manual Reset
F010	Ramp Profile	1	Ramp 1 is voltage ramp with current limit; Ramp 2 is voltage ramp with current limit
F011	Initial Torque	60	60 Percent
F013	Ramp Time	10	10 second time duration for Ramp 1
F014	Current Limit	350	Maximum current limit of Ramp 1 as a percentage (350%).
F015-F018	Ramp 2	60,200,10,350	Inactive unless TB4 control circuit is wired
F019-F021	Jog	50,10,150	Inactive unless TB4 control circuit is wired
F022-F049	All other protection and control features	See Note	Disabled
F050	Aux. Relay #1 (TB2, terminals 1 - 3)	1	Run / Stop
F051	Aux. Relay #2 (TB2, terminals 4 - 6)	2	At Speed / Stop
F052	Aux. Relay #3 (TB2, terminals 7 - 9)	14	Any Fault
F060	Parameter Lock / User Password	0	User password disabled
F066-F070	All Time Values	0	Eastern Standard Time
F075-F083	Fault Histories	Clear	Entered upon occurrence

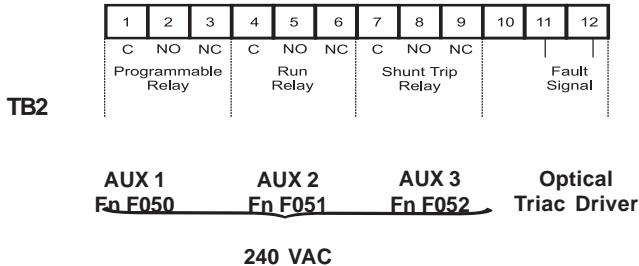

## 6.2 Start-up Check List

- Supply voltage matches the rated supply voltage of the unit.
- Horsepower and current ratings of the motor and unit match or the unit is higher rating.
- Initial ramp time and torque adjustments have been checked.
- Power lines are attached to the unit input terminals marked L1, L2 and L3.
- Motor leads are connected to the lower terminals marked T1, T2, and T3.
- Appropriate control power is applied and/or control connections have been made.
- “Power on” light located on the front of the unit turns on when control power is applied.
- Four seven-segment LED readouts are visible.
- The motor’s FLA has been programmed in function F001.
- The thermal overload is properly set. (Use F003 and F004 to set OL Class.)
- The motor area and equipment are clear of people and parts before start-up.

## 6.3 Sequence of Operation

- Apply three phase power to the unit. The motor should run only when the start command is applied.
- Apply control power and check that the “Power On” LED comes on.
- Verify that the motor’s FLA is correctly programmed (F001).
- Apply the start command. The motor should begin to accelerate.
- When the motor reaches full speed, the “At Speed” LED comes on.
- If the motor decelerates, or stops, during the acceleration period, hit the stop button immediately and open the disconnect line.

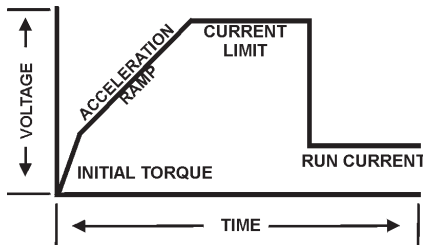

Sequence of Operation

If the unit does not follow this operational sequence please refer to Chapter 8 - Troubleshooting.

## Chapter 7 - Fault Conditions

### 7.1 Fault Codes and Numbers (in History)

#### Fault Code Examples:

Over Load During Accel

Over Current During Accel

(Current) Imbalance During Accel

A three-character fault code is displayed in the LED display at the time of the trip event. For instance, if Function F003 (overload protection) is set too low for the size of the load, the code “oLA” will be displayed. Its corresponding number will be entered into the fault history. In this case, the number 0010 will be available for display in the window of function F075 (Fault History). The time the fault was detected is available in Function F076. It is expressed as hh.mm. So if the “oLA” fault occurred at 10:00 am, F076 would display 10.00. The date the fault occurred is available in Function F077. The date is expressed as mm.dd. So if the “oLA” fault occurred on March 1, F077 would display 03.01.

If there are no fault conditions in history, the display in F075 would read 0000.

History Fault Number (Shown in F075, F078, F081)	Fault Code @ Trip/Event	LED Indicators	Description
1	oCA	Over Current	Over Current During Acceleration
2	oCC	Over Current	Over Current During Constant Speed
3	oCd	Over Current	Over Current During Decel (or Stop)
4	PLA	Phase Loss	Phase Loss During Acceleration
5	PLC	Phase Loss	Phase Loss During Constant Speed
6	PLd	Phase Loss	Phase Loss During Decel (or Stop)
7	oTA	Over Temp	Over Temperature During Acceleration
8	oTC	Over Temp	Over Temperature During Constant Speed
9	oTd	Over Temp	Over Temperature During Decel (or Stop)
10	oLA	Over Load	Over Load During Acceleration
11	oLC	Over Load	Over Load During Constant Speed
12	oLd	Over Load	Over Load During Decel (or Stop)
13	SSA	Shorted SCR	Shorted SCR During Acceleration
14	SSC	Shorted SCR	Shorted SCR During Constant Speed
15	SSd	Shorted SCR	Shorted SCR During Decel (or Stop)
16	ST	Shunt Trip	Shunt Trip During Acceleration
17	ST	Shunt Trip	Shunt Trip During Constant Speed
18	ST	Shunt Trip	Shunt Trip During Decel (or Stop)
19	ibA	NA	Phase Imbalance Current During Acceleration
20	ibC	NA	Phase Imbalance Current During Constant Speed
21	ibd	NA	Phase Imbalance Current During Decel (or Stop)
22	UCA	NA	Under Current During Acceleration
23	UCC	NA	Under Current During Constant Speed
24	UCd	NA	Under Current During Decel (or Stop)
25	SCA	Over Current	Short Circuit During Acceleration
26	SCC	Over Current	Short Circuit During Constant Speed
27	SCd	Over Current	Short Circuit During Decel (or Stop)

## Chapter 8 - Troubleshooting

### 8.1 Failure Analysis

Problem	Possible LED Display	Possible Causes	Solution
One of the main fuses blows or circuit breaker opens when the power is applied	Shunt Trip LEDs: ON	Short circuit between the inputs	Locate and remove the short
		Faulty SCR(s)	Remove power and test the SCR(s). Refer to section 8.2 for SCR Testing procedure.
One of the main fuses blows or circuit breaker opens when the start command is given.	Overcurrent LEDs: ON Phase Loss LEDs: ON	Short circuit or ground fault in motor or cabling	Locate and remove the short or the ground
		Phase Loss	Repair the cause of the phase loss
		Branch circuit protection not correctly sized	Verify the correct sizing of the branch circuit protection
		Faulty SCR(s)	Remove power and test the SCR(s). Refer to section 8.2 for SCR Testing procedure.
		Single phase incoming power	Correct the problem with the incoming power
		Faulty main circuit board	Remove power and replace the PC board assembly. Refer to section 8.4 for circuit board replacement procedure.
Motor overload trips during start	Overload LEDs: ON	Overload improperly adjusted	Adjust the overload (F003)
		Excessive load on motor	Lighten the load on the motor
		Current limit set too low	Increase the current limit set point (F014)
		Incorrect start adjustment	Readjust the starting parameters. Refer to Chapter 5.
Thermostat trips during run	Over Temp LEDs: ON	Fan(s) not functioning	If the fans have power, remove power and replace the fan(s). If the fans do not have power, find the cause of the power loss and repair
		Heatsink coated with dirt	Remove power and clean the heatsink with high pressure air (80-100 PSI max, clean and dry air)
		Over current on unit	Verify that the running current does not exceed the unit rating.
		Environment temperature over 120°F (ambient temperature for panel version) or over 104°F (ambient temperature for enclosed version)	Locate unit where the ambient temperature is less than 120°F for the panel mount version or less than 104°F for the enclosed version
Motor will not start	All LEDs: OFF	No control voltage applied to control board	Apply control voltage to TB1 pins 1 and 6 on the power board
		Control power transformer failure or CPT fuse failure.	Remove power and replace the power transformer or the CPT fuse
	Power On LED: OFF	Start circuit wired incorrectly	Remove power and correct the start circuit wiring
		Start LED: OFF	No start command
	Phase Loss LEDs: ON	No 3 phase line voltage	Apply 3 phase line voltage to the unit
		Failure of PC board assembly	Replace PC board assembly
	Shorted SCR LEDs: ON	Faulty control logic	Remove power and repair the control logic
		Shorted SCR in starter	Refer to section 8.2 for SCR testing procedures and replace the faulty (shorted) SCR(s)
Motor vibrates / Motor growls	Phase Loss LEDs: ON	Faulty motor	Check the motor and the motor connections
		Faulty SCR(s)	Remove power and perform the SCR device checks
		Faulty gate/cathode on SCR(s)	Refer to section 8.2 for SCR testing procedures and replace the faulty (shorted) SCR(s)
		Faulty PC board assembly	Replace PC board assembly
Extremely unbalanced motor currents during start or run mode	Phase Loss LEDs: ON	Faulty motor / wiring	Troubleshoot and repair
		Faulty wiring	Troubleshoot and repair / replace wiring
		Faulty main circuit board	Replace the PC board assembly
Motor stopped during run	Over Current LEDs: ON	<b>Warning:</b> This is a serious fault condition. Ensure that the fault condition is cleared on the load before attempting to restart to motor.	
		Load shorted / grounded/ faulted	Remove power and repair
		Faulty main circuit board	Replace the PC board assembly
External Control circuit fuses blow after control power is applied.	All LEDs: OFF	Short in control circuit	Remove power, locate and remove the short
		Wrong control voltage	Apply the correct voltage to the control circuit

**8.2 SCR Testing Procedure**

Remove both line power and control power from the unit and lock out. Disconnect any two motor load leads and any two line leads. Disconnect the SCR connections to main control board J5, J6 and J7. Refer the Chapter 9 for the main control board layout. Note the type of color coding of the wires connected to J5, J6 and J7. TOSHIBA™ uses two possible configurations. Both configurations have 4 wires going to each plug. The first configuration consists of 4 wires color coded black, yellow, grey and white. The second configuration consists of 4 wires color coded red, white, red, white.

The testing procedure for SCRs is comprised of two separate tests. The first one tests the anode to cathode integrity of the SCR by performing the following ohm checks:

+ Lead	- Lead	Good	Consult factory
L1 Lug	T1 Lug	Greater than 10K ohm	Less than 10K ohm
L2 Lug	T2 Lug	Greater than 10K ohm	Less than 10K ohm
L3 Lug	T3 Lug	Greater than 10K ohm	Less than 10K ohm

The second tests the gate to cathode integrity of the SCR. Place the leads of an ohm meter into the receptacle that was unplugged from the main circuit board. Ohm the pair of wires on one end of the plug. Then ohm the pair of wires on the other end of the plug. The chart below indicates good versus bad readings.

For wire that is color coded black, yellow, gray and white:			
+ Lead	- Lead	Good	Bad
Black	Yellow	Between 5 and 90 ohms	Less than 5, or greater than 90 ohms
Grey	White	Between 5 and 90 ohms	Less than 5, or greater than 90 ohms
For wire that is color coded red, white, red and white:			
Red	White	Between 5 and 90 ohms	Less than 5, or greater than 90 ohms
Red	White	Between 5 and 90 ohms	Less than 5, or greater than 90 ohms

**Note:** If any of the above readings are out of specifications, replace the faulty SCR.

**Note:** The best way to test an SCR is with an SCR Tester and look for leakage current less than the manufacturer specified values.

### 8.3 Replacing SCR Devices

Two types of SCRs are used in the **TD Series** depending on the horsepower/ampere rating of the unit. Isolated SCRs are used in smaller units and “hockey puck” type SCRs are used in larger units. (Refer to Chapter 9 for the main control board layout.)

#### 8.3.1 Changing an Isolated SCR

- Remove both line and control power from unit, tag and lock out.



**Failure to remove both line and control power before starting this procedure may cause personal injury or death.**

- Label the location of wires connected to the SCR.
- Remove the mounting screws, lugs and associated wiring from the existing SCR.
- Make sure the surface to which the power module mounts is clean and free from dirt, nicks and scratches.
- Apply thermal grease uniformly along the grooved area. Spread the grease thinly (3 mil thick) to completely cover the base of the power module and minimize air pockets. The grease must be free of contamination.
- Replace the screws and tighten down firmly. All mounting screws should be 44lb/in. Units with a maximum ampere rating of up to 48A, should use 26 lbs/in busbar and power lugs. Units with a maximum ampere of 60A - 120A should use 44 lbs/in busbar and power lugs.
- Reconnect all busbars, lugs and wires. Check to make sure the gate and cathode are wired correctly. Use the following chart to verify the wiring of J5, J6 and J7:
- After verifying that all wiring is correctly connected, test the SCR.

Main Circuit Board Pin #	Destination
Pin 1	Load Gate
Pin 2	Load cathode (Output Load Lug)
Pin 5	Line Gate
Pin 6	Line Cathode

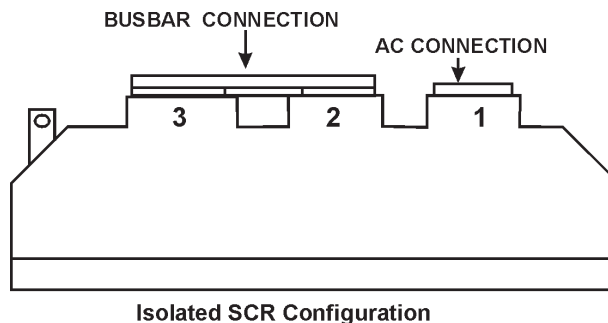

### 8.3.2 Changing a Hockey Puck Type SCR

- Remove both line and control power from unit, tag and lock out.



***Failure to remove both line and control power before starting this procedure may cause personal injury or death.***

- TOSHIBA uses two types of clamps with gauges for reading the amount of force on the device. The first type of force gauge uses a spin washer. When the proper force is applied, the washer will be free to spin. The second type of gauge uses a step indicator on the end of the lever. Before proceeding, note the type of clamp used and, if the clamp has a step indicator, document the position of the indicator before removing the clamp to facilitate proper mounting of the new SCR device.
- Label the location of the wires connected to the SCR.
- Remove any lugs, snubbers, printed circuit boards (refer to section 8.4) and associated wiring that may get in the way of reaching the faulty SCR. Document the location and wiring of all parts before removing them to facilitate the reinstallation of the devices later.
- Document the position of the indicator on the SCR clamp. Then remove the top clamp holding the SCR stack together. Remove the top heatsink. Use extreme caution when handling the heat sink so it does not become dented or damaged.
- Remove the faulty SCR device, noting the direction in which the SCR is oriented. The new SCR puck **must be** inserted in the same direction.
- Make sure the SCR mounting surface, tools, and hands are clean and free from dirt, nicks, and scratches. Do not sand or scrape SCR mounting surface. If necessary, super fine Scotch Brite pads can be used to clean the heatsink before installing the new SCR.
- Apply a thin (3 mil thick) layer of thermal grease uniformly along both sides of the SCR. Spread the grease to cover the entire surface of both sides of the SCR in a manner that minimizes air pockets. The grease must be free of contamination.
- Locate the centering pin in the bottom and top of the heatsink and center it in the SCR hole (making sure that the SCR is pointed in the same direction as the SCR that was removed in step 6). Locate the centering pin in the top heatsink and center it in the SCR hole.  
**If center pin is not placed correctly it will damage the SCR and the heat sink.**  
 Hand tighten the clamps evenly so that the same number of threads appear at both ends of the U-clamp. Tighten the clamp 1/4 turn at a time alternating sides of the U-clamp until the correct force is reached. Check the gauge or spin washer every time the clamp nuts are tightened 1/4 turn to ensure that the SCR is not over torqued. The gauge reading should be similar to the initial reading taken in step 2. If the clamp

uses the spin washer gauge, verify that the washer spins freely after clamping. Once proper force is reached make sure that the SCR pucks are securely held between the heatsinks and aligned evenly.

- Replace any lugs, MOVs, snubbers, power straps, printed circuit boards and associated wiring that was removed in step 4. Use the following chart to verify wiring of J5, J6 and J7:

Main Circuit Board Pin #	Destination
Pin 1	Load Gate
Pin 2	Load cathode (Output Load Lug)
Pin 5	Line Gate
Pin 6	Line Cathode

- After verifying that all wiring is correctly connected, test the SCR and then test the unit.

#### 8.4 Replacing the Printed Circuit Board Assembly

The printed circuit board assembly is not intended to be field repaired. If a board is faulty, the entire assembly should be replaced using the following procedure:  
(See Chapter 9 for the printed board assembly layout.)

- Remove three phase power and control power from the unit and lock out.
- Remove plugs and tag plugs with connector numbers.
- Remove control wires from terminals and tag wires with terminal numbers.
- Remove the mounting screws.
- Remove the old printed circuit board assembly.
- Mount the new printed circuit board assembly.
- Install the mounting screws.
- Install the control wires onto correct terminals per tag sequence.
- Install the plugs.
- Apply power to the unit and test.

## Chapter 9 - Printed Circuit Board Layout

### 9.1 Power Board and CPU Board (PC Board Assembly)

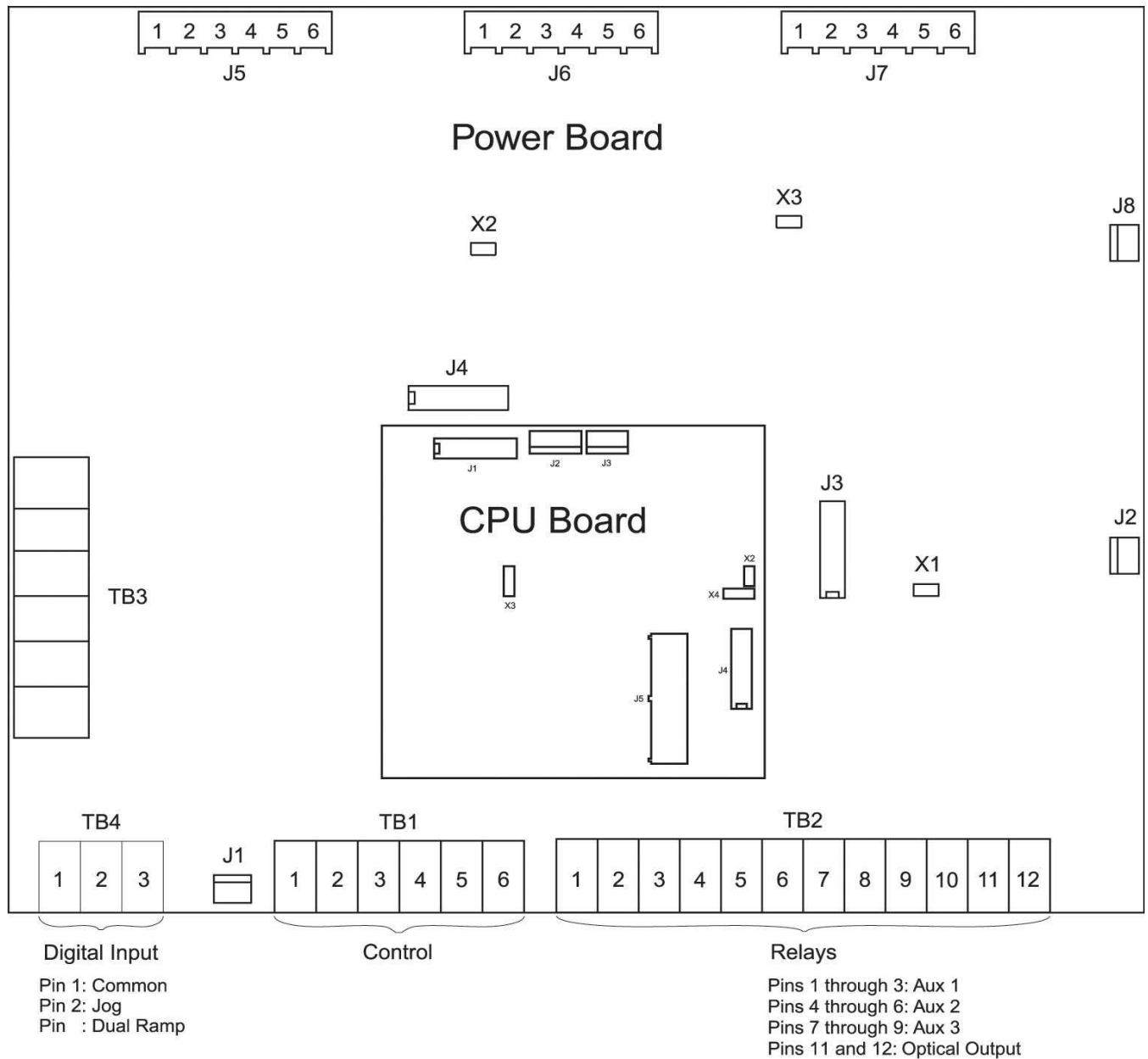

**TD Power Board Jumpers:**

X1 = Phase loss detection. Remove to disable the phase loss detection.  
 X2 = Shorted SCR detection. Remove to disable the shorted SCR detection.  
 (Note: May need to be removed when the TD is connected to a Electronic DC Injection Brake.)  
 X3 = 50Hz/60Hz selection. Remove for 50Hz operation. Jumper installed for 60Hz system.

9.1 Typical Wiring Diagram

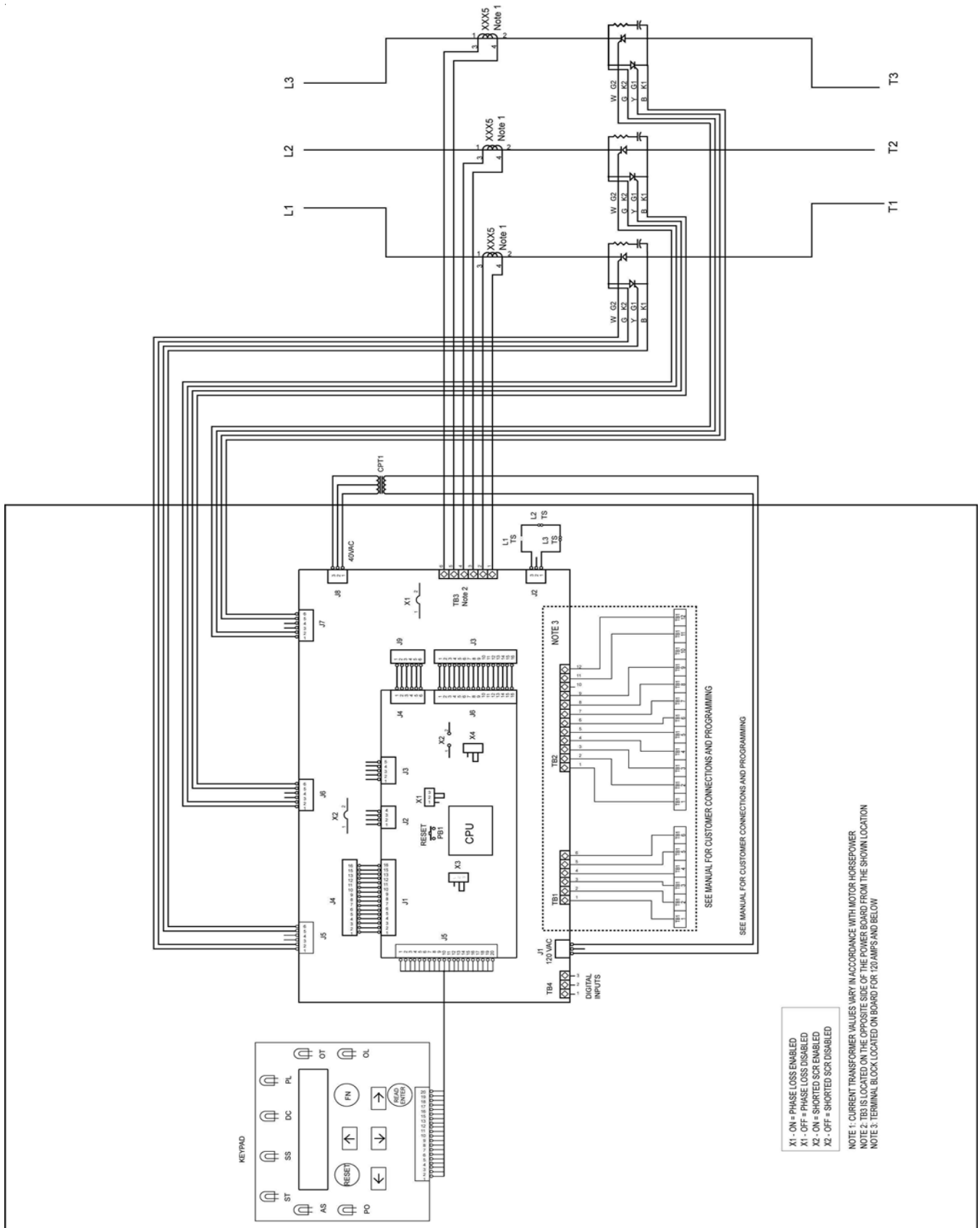

## Appendix 1 - Ramp Profile Details

### Four Different Ramp Types

The **TD Series** offers four different types of starting ramp profiles. Simply select the one that best matches your motor / load requirements.

F010 Ramp Profile Selection	Setting	Ramp Type	
		Ramp 1	Ramp 2
	1	Voltage Ramp	Voltage Ramp
	2	Current Ramp	Current Ramp
	3	Voltage Ramp	Current Ramp
	4	Current Ramp	Voltage Ramp

**1. Voltage Ramping** is the most reliable starting method, since at some point the starter will reach an output voltage high enough to allow the motor to draw full current and develop full torque. This method is useful for applications where the load conditions change frequently and significantly enough to require different levels of starting torque.

Examples where this is effective are:

- material handling conveyers
- positive displacement pumps
- drum mixers, etc.

Voltage is increased from a starting point (Initial Torque) to full voltage over an adjustable period of time (Ramp Time).

To achieve Voltage Ramping, set the Ramp Profile (**F010**) to 0001 or 0003 (Voltage Ramp), and the Maximum Current Limit setting (**F014**) to maximum (600%). Since this is essentially Locked Rotor Current on most motors, there will be little or no Current Limit effect on the Ramp profile.

**2. Voltage Ramping with Current Limit** works similarly to the above, except adds an adjustable maximum current output. Voltage is increased gradually until the Maximum Current Limit setting (**F014**) is reached, then held at this level until the motor accelerates to full speed. This may be necessary in applications where the electrical power is limited.

Examples would be:

- portable or emergency generator supplies
- utility power near the end of a transmission line
- utility starting power demand restrictions.

Using Current Limit will override the Ramp Time setting if necessary, so use this feature when acceleration time is not critical.

To achieve Voltage Ramping with Current Limit, set the Ramp Profile (**F010**) to 0001 or 0003 (Voltage Ramp), and the Maximum Current Limit setting (**F014**) to a desired lower setting, as determined by your applications requirements.

**3. Current Ramping** (Closed Loop Torque Ramping) is good for smooth linear acceleration of output torque. Output voltage is constantly updated to provide this linear current ramp, and therefore the available torque is maximized at any given speed. The best use of this feature is for applications where rapid changes in torque may result in load damage or equipment changes.

Examples would be:

- long overland conveyors where belt stretching may occur
- fans and mixers where blade warping is a problem
- material handling systems where stacked products may fall over or break.

This feature can be used with or without the Maximum Current Limit setting.

To achieve Current Ramping with the **TD**, set the Ramp Profile (**F010**) to 0002 or 0004 (Current Ramp), and the Maximum Current Limit setting (**F014**) to the desired level.

**4. Current Limit Only** (Current Step) starting means using the Current Limit feature exclusively without the benefit of soft starting by ramping the voltage or current first. This will maximize the effective application of motor torque within the limits of the motor. In this mode, Initial Voltage / Current and Ramp Time are set to 0, so the output current jumps to the current limit setting immediately.

Examples of when to use this mode are:

- applications with a severely limited power supply
- when starting a difficult load such as a centrifuge or deep well pump
- when the motor capacity is barely adequate without stalling or overloading.
- It is a good choice when other starting modes fail.

Since ramp times are set to 0, this mode functions in either Voltage Ramp or Current Ramp setting.

#### Ramp Parameter Description

**Initial Torque (Initial Voltage or Initial Current).** This function sets the initial start point of either the Voltage Ramp or Current Ramp as programmed in **F010**. Every load requires at least some amount of torque to start from a standstill. It is not efficient to begin ramping the motor from zero every time, since between zero and the ( $WK^2$ ) break-away torque level, no work is being performed. The initial torque level should be set to provide just enough torque to make the motor shaft begin to rotate, enabling the softest possible start and preventing torque shock damage to the mechanical components. Setting this function too high will not damage the starter, but may reduce or eliminate the soft start advantages. See Chapter 5 for initial setup procedures.

**Accel Ramp Time.** This Function sets the maximum allowable time for ramping the Initial voltage or current (torque) setting to either of the following:

- 1) Current limit setting when the motor is still accelerating, or
- 2) Full output voltage if the Current Limit is set to maximum.

Increasing the Ramp Time softens the start process by lowering the slope of increase in voltage or current. This should be set to provide the softest possible start without stalling unless you have determined that your application has other considerations. Applications where this setting should be shorter include Centrifugal Pumps, because pump problems may occur as a result of insufficient torque during acceleration through the pump curve.

**Note:** Ramp Time is affected by the following conditions:

1. Current Limit will extend the Ramp Time if the motor does not reach full speed while in current limit mode.
2. The Anti-Oscillation Circuit will shorten the Ramp Time if the motor reaches full speed before end of ramp.

**Current Limit.** This Function sets the maximum motor current that the starter allows during Ramping. It is active in both the Voltage Ramp and Current Ramp modes. As the motor begins to ramp, this feature will set a ceiling at which the current draw will be held. Current Limit will remain in effect until one of the following two events occur:

- 1) The motor reaches full speed as detected by the At-Speed detection circuit.

2) The Overload Protection trips on Motor Thermal Overload (see Ch.3).

Once the motor has reached full speed, the Current Limit feature becomes inactive.

In the Voltage Ramp Profile, the Voltage output is increased until the Current Limit is reached. The Ramp Time is the maximum time it will take for the voltage to increase until the Current Limit setting takes over. Under some load conditions, Current Limit may be reached before the Ramp Time has expired.

In the Current Ramp Profile, output voltage varies to provide a linear increase in current up to the Current Limit setting, and Ramp Time is the time that it will take to get there. A closed loop feedback of motor current allows continuous updating of the output to maintain this ramp profile.

Because most AC induction motors will not start below 200% current, the current limit set point is adjustable down to only 200%.. Use this feature to prevent voltage drop in your electrical supply, portable / emergency generator stalling, or to satisfy utility restrictions on starting power.

**⚠CAUTION**

**While the TD is in Start mode there is no maximum Current Limit time. Excessive start time may however lead to motor stalling, causing an Overload Trip. If this happens, try raising the Current Limit setting to accommodate your load conditions. If the Current Limit setting cannot be increased, try using Current Limit without ramping features (“Current Limit Only” as described previously).**

## Appendix 2: Decel Mode Application Considerations

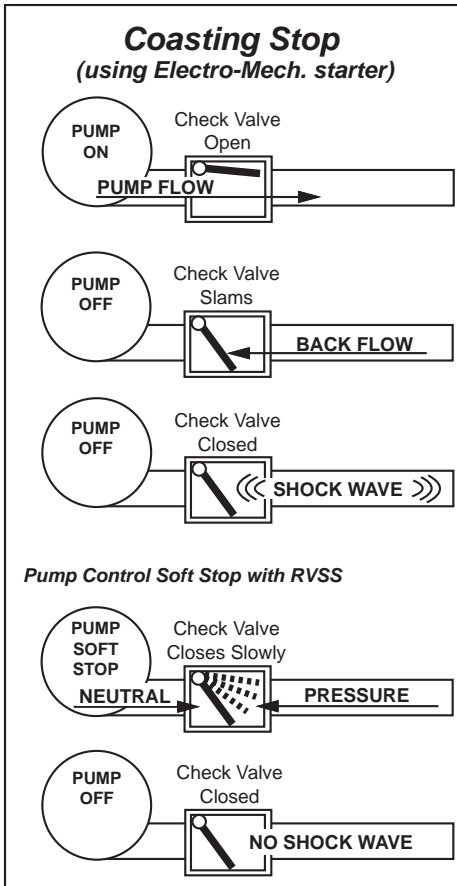

Deceleration (Soft Stop) is a unique feature of Solid State Soft Starters such as the **TD**. It provides a slow decrease in the output voltage, accomplishing a gentle decrease in motor torque during the stopping mode. This is the **OPPOSITE OF BRAKING** in that it will take **longer** to come to a stop than if the starter were just tuned off. The primary use of this function is with centrifugal pumps as a means to reduce the sudden changes in pressure that are associated with “Water Hammer” and slamming of check valves. Decel control in pump applications is often referred to as **Pump Control**.

In a pump system, liquid is being pushed uphill. The force exerted by gravity on the column of liquid as it goes up hill is called the “Head Pressure” in the system. The pump is sized to provide enough Output Pressure to overcome the Head Pressure and move the fluid up the pipe. When the pump is turned off, the Output Pressure rapidly drops to zero and the Head Pressure takes over to send the fluid back down the hill. A “Check Valve” is used somewhere in the system to prevent this (if necessary) by only allowing the liquid to flow in one direction. The kinetic energy in that moving fluid is suddenly trapped when the valve slams closed. Since fluids can’t compress, that energy is transformed into a “Shock Wave” that travels through the piping system looking for an outlet in which to dissipate. The sound of that shock wave is referred to as “Water Hammer”. The energy in that shock wave can be extremely damaging to pipes, fittings, flanges, seals and mounting systems.

By using the Soft Stop deceleration feature of the **TD**, the pump output torque is gradually and gently reduced, which slowly reduces the pressure in the pipe. When the Output Pressure is just slightly lower than the Head Pressure, the flow slowly reverses and closes the Check Valve. By this time there is very little energy left in the moving fluid and the Shock Wave is avoided. When the output voltage to the motor is low enough to no longer be needed, the **TD** will end the Decel cycle and turn itself off.

Another common application is on material handling conveyors as a means to prevent sudden stops that may cause products to fall over or to bump into one another. In overhead crane applications, Soft Stopping of the Bridge or Trolley can prevent loads from beginning to over swing on sudden stops.

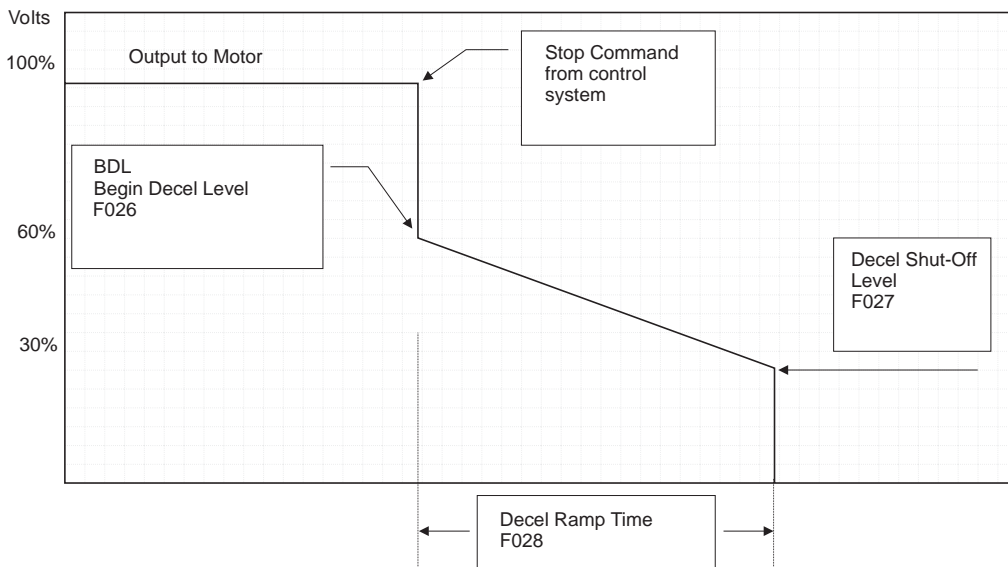

## Appendix 3: Parameter Lock / User Password Instructions

**F060 = Parameter Lock / User Password**  
**Factory Setting = 0 (disabled)**  
**Range = 0 - 999**

Provides users with the ability to prevent unauthorized operators from making changes to the programmed functions. **If you do not need to take advantage of this feature, do not enter anything into this function.** The factory default is disabled, and no Password is necessary to make changes to the program.

When any value other than 0 is entered into this Function, the Parameter Lock is enabled and that number becomes the User Password. From that point forward, it will be necessary to enter the User Password in this Function prior to making changes in any programmed function, including this one. When the Parameter Lock has been enabled, attempts to alter the program will result in the display reading **Err** whenever the **READ / ENTER** key is pressed.

To be able to alter the program after the Parameter Lock has been enabled, go to Function (**F060**) and enter the correct user Password. When the **READ / ENTER** button is pressed, the display will read **PASS**, indicating that the User Password is correct and the system is unlocked. You will have 5 minutes in which to make a change in the program. This 5 minute window resets whenever any key is pressed, so it floats to give you 5 minutes after the last entry. After 5 minutes of no keypad activity, the Parameter Lock is reinstated with the current user Password. Subsequent changes will require re-entering the User Password.

To change the User Password or to disable **the** Parameter Lock **function**, enter the programmed User Password first, then set Function F060 to 0 (F060 = 0), disabling the Parameter Lock. If you do not re-enter the Password or enter a new user password, **the** Parameter Lock **feature** will remain disabled. If you enter a different number **into this Function**, the new number becomes your new User Password.

The User Password will not be displayed after being entered or at any other time. The number displayed after the READ / ENTER key is initially pressed is for reference only. **Caution: DONOT LOSE YOUR PASSWORD.** If the password has been lost or forgotten, contact TOSHIBA **for assistance in retrieving it with authorization.**

### Enabling Password Protection / Parameter Lock (See Example)

Start from the Status Display Mode.

Press the **Fn** key.

Press the **LEFT** arrow to select the second digit (from the right)

Press the **UP** arrow six times (6x) to change the function code to F061.

Press the **RIGHT** arrow to select the first digit (from the right).

Press the **DOWN** arrow to change the function code to F060.

Press the **Read Enter** key. The display should "hide" the password.

Use the **UP** arrow and the **LEFT** arrow to display the password you desire (Valid range is 0000 to 0999).

In this example, 0123 has been selected.

Press the **Read Enter** key. The word [END\_] should momentarily display to confirm you have enabled the user password feature.

### Disabling Password Protection / Parameter Lockout

Changing function F060 to 0000 will disable the user password.

**Example**  
**Password = 0123**  
**Enabling Password Protection**

## Appendix 4 - Soft Starter Settings

The following chart may be used to record the changes made to the factory settings.

Fn	Function	Page	Set To	Check	Revised	Check	
F001	Motor FLA	20					
F002	Service Factor	21					
F003	Overload Class During Start	21					
F004	Overload Class During Run	21					
F005	Overload Reset	21					
F006-F009	Reserved	No record required					
F010	Ramp Select	21					
F011	Initial Voltage of Ramp 1	22					
F012	Initial Current of Ramp 1	22					
F013	Accel Ramp Time of Ramp 1	22					
F014	Max Current Limit of Ramp 1	22					
F015	Initial Voltage of Ramp 2	23					
F016	Initial Current of Ramp 2	23					
F017	Accel Ramp Time of Ramp 2	23					
F018	Max Current Limit of Ramp 2	23					
F019	Voltage Jog	24					
F020	Time of Voltage Jog	24					
F021	Current Jog	24					
F022	Kick Start	24					
F023	Kick Voltage	24					
F024	Kick Time	25					
F025	Deceleration Ramp	25					
F026	Begin Decel Level (BDL)	25					
F027	Decel Shut Off Voltage	25					
F028	Decel Ramp Time	25					
F029	Reserved	No record required					
F030	Current Imbalance Trip	26					
F031	Current Imbalance Trip %	26					
F032	Current Imbalance Trip Delay	26					
F033	Over Current Trip	26					
F034	Over Current Trip %	26					
F035	Over Current Trip Delay	26					
F036	Under Current Trip	26					
F037	Under Current Trip %	26					
F038	Under Current Trip Delay	26					
F039	Coast Down Lockout Timer	27					

Fn	Function	Page	Set To	Check	Revised	Check	
F040	Coast Down Lockout Time	27					
F041	Starts per Hour Lockout	27					
F042	Maximum Starts per Hour	27					
F043	Time Between Starts Lockout	27					
F044	Minimum Time Between Starts	27					
F045-F049	Coast Down, Starts/Hr, Thermal Capacity	Display Only					
F050	Aux Relay 1 Setting	28					
F051	Aux Relay 2 Setting	28					
F052	Aux Relay 3 Setting	28					
F053-F054	Reserved	No record required					
F055	Communications	29					
F056	Baud Rate	29					
F057	Modbus Address	29					
F058-F059	Reserved	No record required					
F060	Parameter Lock/Customer Password	29					
F061	Reset Factory Default Settings	29					
F062	Reserved	No record required					
F063	Factory Use	No record required					
F064	Factory Use	No record required					
F065	Year	30					
F066	Month	30					
F067	Day	30					
F068	Hour	30					
F069	Minute	30					
F070	Second	30					
F071	Factory Use	No record required					
F072-F074	Reserved	No record required					
F075	Fault History #1, Latest Fault	30					
F076	Time Stamp, Fault #1	30					
F077	Date Stamp, Fault #1	30					
F078	Fault History #2, Previous Fault	31					
F079	Time Stamp, Fault #2	31					
F080	Date Stamp, Fault #2	31					
F081	Fault History #3, Oldest Fault	31					
F082	Time Stamp, Fault #3	31					
F083	Date Stamp, Fault #3	31					
F084-F087	Reserved	No record required					

## Warranty Policy

Toshiba International Corporation ("Company") warrants that all equipment and parts described herein will be free from defects in materials and workmanship. THIS WARRANTY WILL EXPIRE EIGHTEEN (18) MONTHS AFTER THE DATE ON WHICH SUCH EQUIPMENT AND PARTS (EXCLUDING REPAIRED OR REPLACEMENT EQUIPMENT AND PARTS FURNISHED PURSUANT TO THIS WARRANTY) ARE SHIPPED BY THE COMPANY TO THE INITIAL PURCHASER OR TWELVE (12) MONTHS AFTER SUCH EQUIPMENT AND PARTS (EXCLUDING REPAIRED OR REPLACEMENT EQUIPMENT AND PARTS FURNISHED PURSUANT TO THIS WARRANTY) ARE FIRST PLACED IN OPERATION, WHICHEVER PERIOD FIRST EXPIRES.

The Company will, at its option, repair or replace such equipment or part which is defective under the terms of the foregoing warranty, free of charge; provided the purchaser (1) promptly notifies the Company in writing of such defect, and (2) furnishes the Company satisfactory proof thereof, and (3) establishes that the equipment or part has been properly installed, maintained and operated within the limits of rated capacity and normal usage and in accordance with this manual, and (4) if requested by the Company, returns the defective equipment or part to the Company and pays all expenses incurred in connection with such return. The repaired or replacement equipment or part will be delivered, free of charge, to the purchaser F.O.B. the Company's warehouse or, at the Company's option, F.O.B. a Company authorized service shop, not loaded on truck or other carrier. The purchaser will pay the costs applicable to the equipment or part following such delivery, including, without limitation, all handling, transportation, assembly, insurance, testing and inspection charges.

THE FOREGOING OBLIGATION TO REPAIR OR REPLACE EQUIPMENT PARTS SHALL BE THE SOLE AND EXCLUSIVE REMEDY OF THE PURCHASER, ITS CUSTOMERS AND USERS OF THE EQUIPMENT AND PARTS FOR BREACH OF THE FOREGOING WARRANTY. THE COMPANY WILL HAVE NO OBLIGATIONS TO DISASSEMBLE ANY EQUIPMENT OR PART WHICH IS DEFECTIVE WITHIN THE TERMS OF THE ABOVE WARRANTY OR TO INSTALL ANY REPAIRED OR REPLACEMENT PART OR EQUIPMENT OR TO PAY ANY COSTS INCURRED IN CONNECTION WITH ANY SUCH DISASSEMBLY OR INSTALLATION. THE COMPANY, TOSHIBA CORPORATION AND THEIR SUPPLIERS AND SUBCONTRACTORS HEREBY DISCLAIM ALL OTHER EXPRESS, STATUTORY AND IMPLIED WARRANTIES, INCLUDING, WITHOUT LIMITATION, ALL EQUIPMENT AND PARTS FURNISHED PURSUANT TO THE FOREGOING WARRANTY AND ALL IMPLIED WARRANTIES OF MERCHANTABILITY.

The total liability of the Company, Toshiba Corporation and their suppliers and subcontractors for any loss, damage or claim, whether in contract, tort (including negligence and liability without fault), or otherwise, arising out of, connected with or resulting from the equipment and parts described in this manual or the performance or breach of any contract for the sale or supply of such equipment and parts, or from the design, manufacture, sale, delivery, resale, installation, technical direction or supervision of installation, inspection, testing, repair, replacement, operation, maintenance or use of any such equipment or part or any service relating thereto furnished by the Company shall not in any event exceed the price allocable to the equipment, part or service which gives claim, loss or damage. In no event, whether as a breach of contract or warranty, alleged negligence, liability without fault, or otherwise, shall the Company, Toshiba Corporation or their suppliers or subcontractors be liable for special or consequential damages, including, without limitation, loss or profits or revenue, loss of equipment described herein or any associated equipment, cost of capital, cost of substitute equipment or parts, facilities or services, down-time costs, labor costs or claims of customers of the purchaser for such damages.