

# HL-G1 SERIES

Related Information

- General terms and conditions..... F-7
- Sensor selection guide ..... P.1055~
- Glossary of terms / General precautions ..... P.1493 / P.1501
- About laser beam..... P.1499~

- FIBER SENSORS
- LASER SENSORS
- PHOTOELECTRIC SENSORS
- MICRO PHOTOELECTRIC SENSORS
- AREA SENSORS
- LIGHT CURTAINS / SAFETY COMPONENTS
- PRESSURE / FLOW SENSORS
- INDUCTIVE PROXIMITY SENSORS
- PARTICULAR USE SENSORS
- SENSOR OPTIONS
- SIMPLE WIRE-SAVING UNITS
- WIRE-SAVING SYSTEMS
- MEASUREMENT SENSORS
- STATIC ELECTRICITY PREVENTION DEVICES
- LASER MARKERS
- PLC
- HUMAN MACHINE INTERFACES
- ENERGY CONSUMPTION VISUALIZATION COMPONENTS
- FA COMPONENTS
- MACHINE VISION SYSTEMS
- UV CURING SYSTEMS

- Selection Guide
- Laser Displacement
- Magnetic Displacement
- Collimated Beam
- Digital Panel Controller
- Metal-sheet
- Double-feed Detection

- HL-G1
- HL-C2
- HL-C1



**!** This product is classified as a Class 2 (specular reflection type: Class 1) Laser Product in IEC / JIS standards and in FDA\* regulations. Do not look at the laser beam directly or through optical system such as a lens.

\*This product complies with 21 CFR 1040.10 and 1040.11 Laser Notice No. 50, dated June 24, 2007, issued by CDRH (Center for Devices and Radiological Health) under the FDA (Food and Drug Administration).

## Introducing the new standard in CMOS laser displacement sensors

This single instrument delivers both high-precision measurement and computer-driven data analysis.

### High resolution of **0.5 μm 0.02 mil**

Thanks to high-precision measurement at a resolution of 0.5 μm 0.02 mil and an LED digital display that provides exceptional ease of use, the HL-G1 series will see use in a variety of applications on production lines worldwide.



Diffuse reflection type	Specular reflection type
<b>HL-G103</b> □ Measurement range: 30 ±4 mm Resolution: 1.181 ±0.157 in Resolution: 0.5 μm 0.020 mil Linearity: ±0.1 % F.S. Beam diameter: 0.1 × 0.1 mm 0.004 × 0.004 in	<b>HL-G103A</b> □ <b>NEW</b> Measurement range: 26.3 ±2 mm Resolution: 1.035 ±0.079 in Resolution: 0.5 μm 0.020 mil Linearity: ±0.2 % F.S. Beam diameter: 0.1 × 0.1 mm 0.004 × 0.004 in
<b>HL-G105</b> □ Measurement range: 50 ±10mm Resolution: 1.969 ±0.394 in Resolution: 1.5 μm 0.059 mil Linearity: ±0.1 % F.S. Beam diameter: 0.5 × 1.0 mm 0.020 × 0.039 in	<b>HL-G105A</b> □ <b>NEW</b> Measurement range: 47.3 ±5 mm Resolution: 1.862 ±0.197 in Resolution: 1.5 μm 0.059 mil Linearity: ±0.2 % F.S. Beam diameter: 0.1 × 0.1 mm 0.004 × 0.004 in
<b>HL-G108</b> □ Measurement range: 85 ±20 mm Resolution: 3.346 ±0.787 in Resolution: 2.5 μm 0.098 mil Linearity: ±0.1 % F.S. Beam diameter: 0.75 × 1.25 mm 0.030 × 0.049 in	<b>HL-G108A</b> □ <b>NEW</b> Measurement range: 82.9 ±10 mm Resolution: 3.264 ±0.394 in Resolution: 2.5 μm 0.098 mil Linearity: ±0.2 % F.S. Beam diameter: 0.2 × 0.2 mm 0.008 × 0.008 in
<b>HL-G112</b> □ Measurement range: 120 ±60 mm Resolution: 4.724 ±2.362 in Resolution: 8 μm 0.315 mil Linearity: ±0.1 % F.S. Beam diameter: 1.0 × 1.5 mm 0.039 × 0.059 in	
<b>HL-G125</b> □ <b>NEW</b> Measurement range: 250 ±150 mm Resolution: 9.843 ±5.906 in Resolution: 20 μm 0.787 mil Linearity: ±0.3 % F.S. Beam diameter: 1.75 × 3.5 mm	

**APPLICATIONS**

**Controlling the height of a dispenser nozzle**



**Positioning of wafer**



**Measuring the eccentricity of a metal shaft**

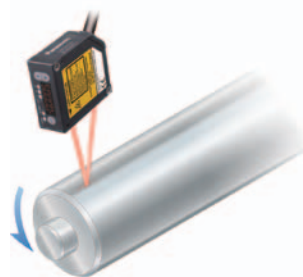

**Detection of circuit board warpage**

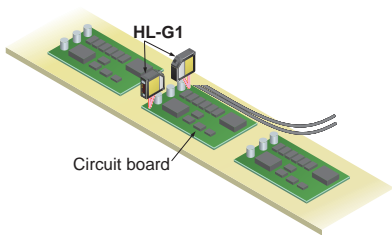

**Measurement of sheet thickness**

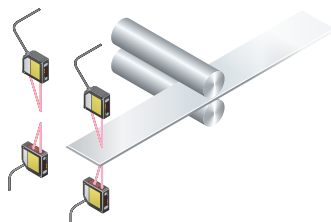

**Testing sheet slack**

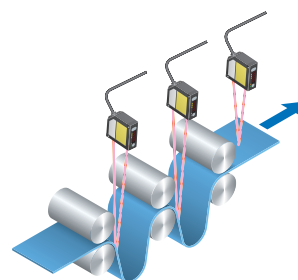

**BASIC PERFORMANCE**

**Easy input settings while looking at digital display**

The built-in digital display makes it easy to perform sensor setting while checking displacement values.

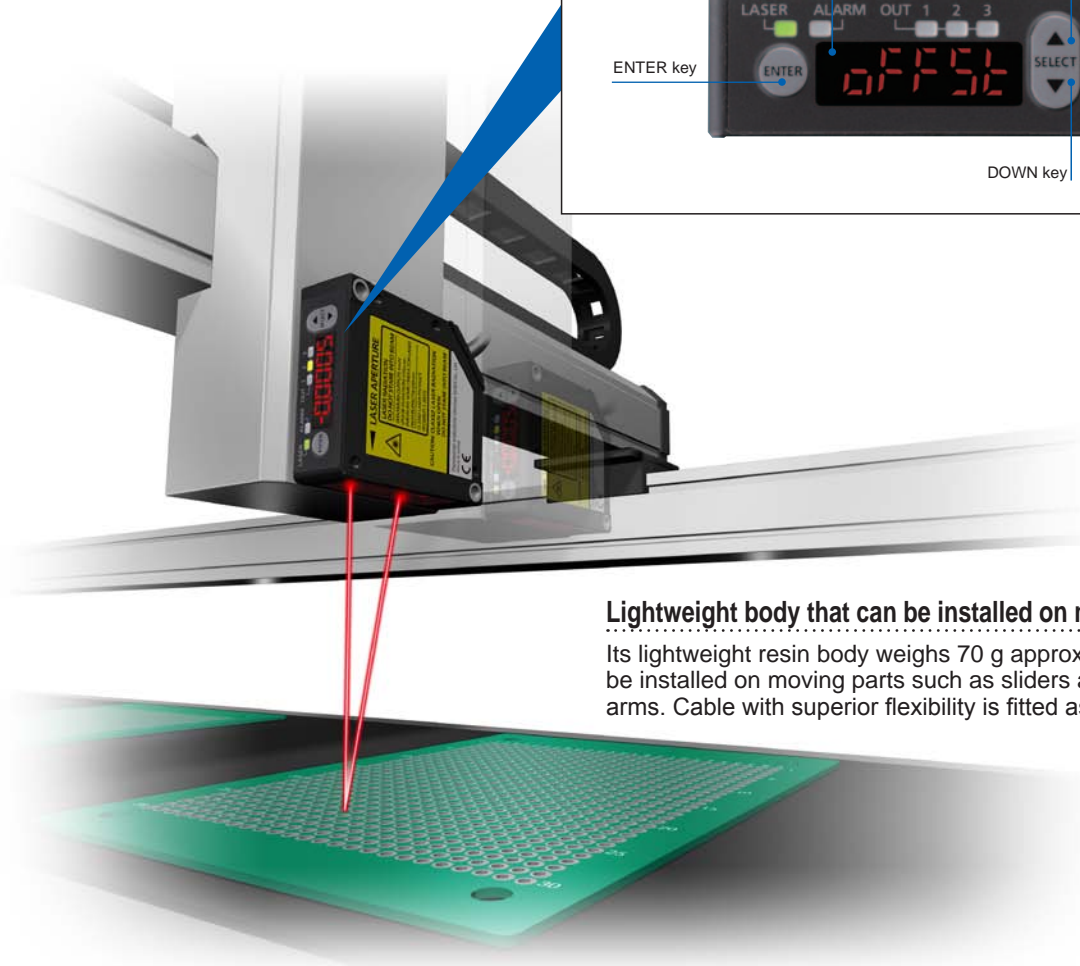
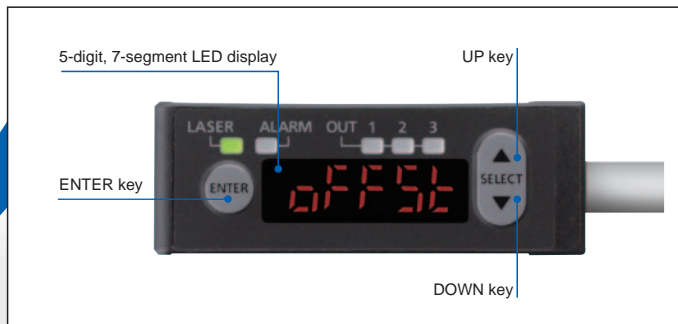

**Lightweight body that can be installed on movable parts**

Its lightweight resin body weighs 70 g approx., which can be installed on moving parts such as sliders and robot arms. Cable with superior flexibility is fitted as standard.

FIBER SENSORS

LASER SENSORS

PHOTOELECTRIC SENSORS

MICRO PHOTOELECTRIC SENSORS

AREA SENSORS

LIGHT CURTAINS / SAFETY COMPONENTS

PRESSURE / FLOW SENSORS

INDUCTIVE PROXIMITY SENSORS

PARTICULAR USE SENSORS

SENSOR OPTIONS

SIMPLE WIRE-SAVING UNITS

WIRE-SAVING SYSTEMS

MEASUREMENT SENSORS

STATIC ELECTRICITY PREVENTION DEVICES

LASER MARKERS

PLC

HUMAN MACHINE INTERFACES

ENERGY CONSUMPTION VISUALIZATION COMPONENTS

FA COMPONENTS

MACHINE VISION SYSTEMS

UV CURING SYSTEMS

Selection Guide

Laser Displacement

Magnetic Displacement

Collimated Beam

Digital Panel Controller

Metal-sheet Double-feed Detection

**HL-G1**

**HL-C2**

**HL-C1**

**Compact**

Compact size despite the built-in controller and digital read out.



**Easy to embed in machines and production lines**

Controller installation and mounting space is not required because controller function is included in sensor unit.

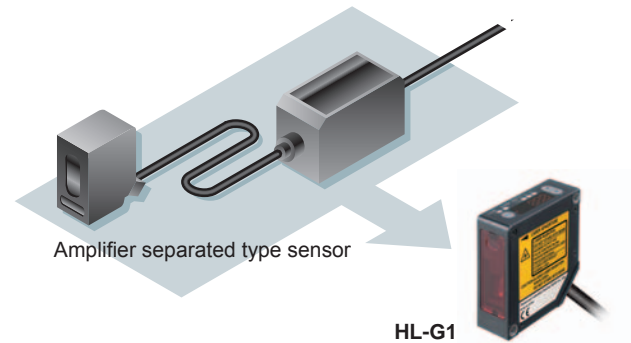

**IP67 protective enclosure protects from water and dust**

Thanks to its IP67 protective enclosure, the **HL-G1** can be used in the presence of water and dust. Mounting holes are lined with metal sleeves, allowing the instrument to be tightened securely in place with up to 0.8 N·m of torque.



**FUNCTIONS**

**Timing input and multi input**

In addition to timing input select the desired input according to your application:

- Zero set on/off
- Laser control
- Reset
- Teaching
- Memory switching
- Saving

**Support for both NPN and PNP polarity** **GLOBAL SUPPORT**

A single model number accommodates both NPN and PNP wiring polarity, reducing the number of model numbers that must be registered for maintenance purposes.

**Featuring 3 outputs and an analog 2 outputs**

With three outputs, the **HL-G1** can be used to generate HI / GO / LOW judgment output or alarm output. The analog output can be used in both current and voltage modes.

**Memory switching function**

Up to four groups of sensor settings can be stored for fast recall. Easy switching among setting groups allows smooth setup changes.

**HIGH FUNCTION TYPE**

**The integrated communications interface lets the sensor communicate with upstream devices such as PLCs.**

Sensors and other devices can be connected in a 1:1 manner using RS-422, or up to 16 **HL-G1** series sensors can be connected using RS-485, enabling them to return measured values in response to messages from the PLC. When using one of our PLCs\*, you can use the PLC's data write/read instructions (F145 and F146) to easily configure **HL-G1** series settings and acquire measurement output.

\*Supported PLCs from Panasonic Industrial Devices SUNX: **FP0R, FPΣ, FP-X**

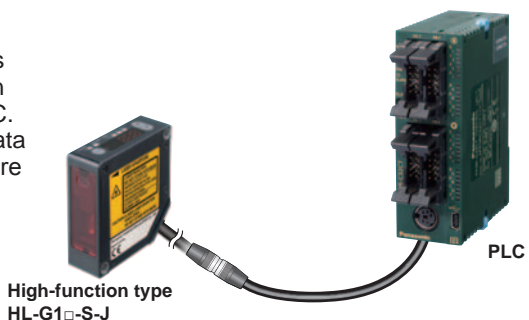

- FIBER SENSORS
- LASER SENSORS
- PHOTOELECTRIC SENSORS
- MICRO PHOTOELECTRIC SENSORS
- AREA SENSORS
- LIGHT CURTAINS / SAFETY COMPONENTS
- PRESSURE / FLOW SENSORS
- INDUCTIVE PROXIMITY SENSORS
- PARTICULAR USE SENSORS

- SENSOR OPTIONS
- WIRE-SAVING UNITS
- WIRE-SAVING SYSTEMS

**MEASUREMENT SENSORS**

- STATIC ELECTRICITY PREVENTION DEVICES
- LASER MARKERS
- PLC
- HUMAN MACHINE INTERFACES
- ENERGY CONSUMPTION VISUALIZATION COMPONENTS
- FA COMPONENTS
- MACHINE VISION SYSTEMS
- UV CURING SYSTEMS

- Selection Guide
- Laser Displacement
- Magnetic Displacement
- Collimated Beam
- Digital Panel Controller
- Metal-sheet Double-feed Detection

- HL-G1**
- HL-C2
- HL-C1

**HIGH FUNCTION TYPE****Software tool for sensor configuration and evaluation (Free download available)**

In addition to configuring up to 16 sensors at once, this free tool makes it easy to gather data needed for analysis, such as received light waveform monitoring and data buffering. The interface language can be selected at the time of installation.

- **Data buffering**  
Stores and displays measurement data, which can be superimposed on previously recorded data for easy comparison and analysis.
- **Received light waveform display**  
Displays the amount of light received by cell from light-receiving element.
- **Measured value display**  
Displays measured values as well as the output state for each terminal.

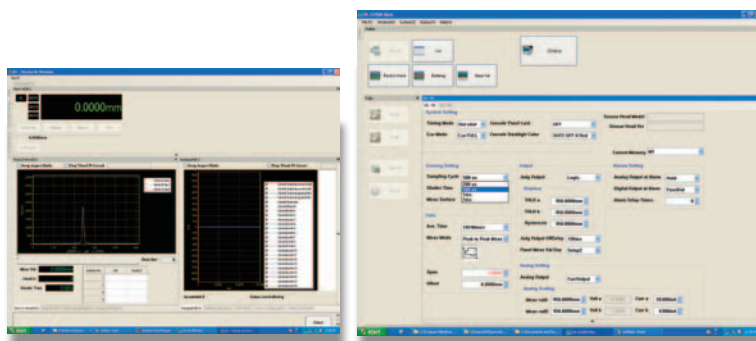
**HMI screen (Free download available)**

The **GT02 / GT12** series HMI can be used in combination with the **HL-G1** to allow easy confirmation of sensor status and configuration of sensor settings from a remote location. Japanese, English, Chinese, and Korean are supported. For more information about the **GT** series, visit our website or refer to our catalog.

**Select from the following HMI operator panels:**

Power supply: 24 V  
Communication port: RS422  
(RS485)

- AIG02GQ14D
- AIG02MQ15D
- AIG12GQ14D / AIG12GQ15D
- AIG12MQ14D / AIG12MQ15D



Refer to the programable display **GT** series pages.

**Multilingualization****GLOBAL SUPPORT**

Software tool and HMI screen data support not only Japanese and English, but also Chinese and Korean, providing a new level of support for devices and equipment in use worldwide.

**Terms of use**

Panasonic Industrial Devices SUNX offers no warranty for this software and is not liable for any loss or damage suffered as a result of its use or operation, whether direct, indirect, incidental, consequential, or unforeseen.

FIBER SENSORS

LASER SENSORS

PHOTOELECTRIC SENSORS

MICRO PHOTOELECTRIC SENSORS

AREA SENSORS

LIGHT CURTAINS / SAFETY COMPONENTS

PRESSURE / FLOW SENSORS

INDUCTIVE PROXIMITY SENSORS

PARTICULAR USE SENSORS

SENSOR OPTIONS

SIMPLE WIRE-SAVING UNITS

WIRE-SAVING SYSTEMS

MEASUREMENT SENSORS

STATIC ELECTRICITY PREVENTION DEVICES

LASER MARKERS

PLC

HUMAN MACHINE INTERFACES

ENERGY CONSUMPTION VISUALIZATION COMPONENTS

FA COMPONENTS

MACHINE VISION SYSTEMS

UV CURING SYSTEMS

Selection Guide

Laser Displacement

Magnetic Displacement

Collimated Beam



Digital Panel Controller

Metal-sheet Double-feed Detection

**HL-G1****HL-C2****HL-C1**

**ORDER GUIDE**

When using the high function type sensor, please order the extension cable separately.

Type	Appearance	Measurement center distance and measuring range	Resolution	Beam diameter	Model No.	Laser class	
Diffuse reflection type	 <p>Standard type</p>	Standard type	30 ±4 mm 1.181 ±0.157 in	0.5 μm 0.020 mil	0.1 × 0.1 mm 0.004 × 0.004 in	HL-G103-A-C5	
		High function type				HL-G103-S-J	
		Standard type	50 ±10 mm 1.969 ±0.394 in	1.5 μm 0.059 mil	0.5 × 1 mm 0.020 × 0.039 in	HL-G105-A-C5	
		High function type				HL-G105-S-J	
		Standard type	85 ±20 mm 3.346 ±0.787 in	2.5 μm 0.098 mil	0.75 × 1.25 mm 0.030 × 0.059 in	HL-G108-A-C5	
		High function type				HL-G108-S-J	
	High function type	 <p>High function type</p>	Standard type	120 ±60 mm 4.724 ±2.362 in	8 μm 0.315 mil	1.0 × 1.5 mm 0.039 × 0.059 in	HL-G112-A-C5
			High function type				HL-G112-S-J
			Standard type	250 ±150 mm 9.843 ±5.906 in	20 μm 0.787 mil	1.75 × 3.5 mm 0.069 × 0.138 in	<b>NEW</b> HL-G125-A-C5
			High function type				<b>NEW</b> HL-G125-S-J
			Standard type	26.3 ±2 mm 1.035 ±0.079 in	0.5 μm 0.020 mil	0.1 × 0.1 mm 0.004 × 0.004 in	<b>NEW</b> HL-G103A-RA-C5
			High function type				<b>NEW</b> HL-G103A-RS-J
Specular reflection type		Standard type	47.3 ±5 mm 1.862 ±0.197 in	1.5 μm 0.059 mil	<b>NEW</b> HL-G105A-RA-C5		
		High function type			<b>NEW</b> HL-G105A-RS-J		
		Standard type	82.9 ±10 mm 3.264 ±0.394 in	2.5 μm 0.098 mil	0.2 × 0.2 mm 0.008 × 0.008 in	<b>NEW</b> HL-G108A-RA-C5	
		High function type			<b>NEW</b> HL-G108A-RS-J		
		Standard type					
		High function type					

FDA / IEC: Class 2

FDA / IEC: Class 1

**OPTIONS**

When using the high function type sensor, please order the extension cable separately.

Type	Appearance	Model No.	Description
Extension cable (for High function type)		HL-G1CCJ2	Length: 2 m 6.562 ft, Weight: 130 g approx.
		HL-G1CCJ5	Length: 5 m 16.404 ft, Weight: 320 g approx.
		HL-G1CCJ10	Length: 10 m 32.808 ft, Weight: 630 g approx.
		HL-G1CCJ20	Length: 20 m 65.617 ft, Weight: 1,300 g approx.
			14-core cabtyre cable with connector on both ends

## OPERATING ENVIRONMENT OF SOFTWARE TOOL

Operating environment				
PC environment	PC / AT compatible			
OS	OS	32 bits / 64 bits	Edition	Service Pack
	Windows® XP	32 bits	Professional	SP2 or later
	Windows® Vista		Business	
	Windows® 7	32 bits / 64 bits	Professional	—
CPU	Intel Pentium® 4 2 GHz or more, either equaling or surpassing			
Graphics	XGA (1,024 × 768 256 colors) or more			
Memory	1 GB or more			
Hard disk	Free space 100 MB or more			
USB interface	USB 2.0 full speed (USB 1.1 compatible)			

Notes: 1) This software accommodates below language. You can select the language when installing.

Japanese, English, Korean, Chinese

2) Windows® 7 Professional, Vista Business, and XP Professional are trademarks or registered trademarks of Microsoft Corporation in the United States and other countries.

## INFORMATION OF INTERFACE CONVERTER

The communications interface converter of **HL-G1** series is RS-422 or RS-485. Use the HMI operator panel **GT02** or **GT12** (through mode) or the following interface converter when using the tool software **HL-G1SMI** and connecting to PC by USB.

<p>LINEEYE CO., LTD. Interface converter (USB to RS-422/485) SI-35USB</p>
---

FIBER SENSORS

LASER SENSORS

PHOTO-ELECTRIC SENSORS

MICRO PHOTO-ELECTRIC SENSORS

AREA SENSORS

LIGHT CURTAINS / SAFETY COMPONENTS

PRESSURE / FLOW SENSORS

INDUCTIVE PROXIMITY SENSORS

PARTICULAR USE SENSORS

SENSOR OPTIONS

SIMPLE WIRE-SAVING UNITS

WIRE-SAVING SYSTEMS

MEASURE-MENT SENSORS

STATIC ELECTRICITY PREVENTION DEVICES

LASER MARKERS

PLC

HUMAN MACHINE INTERFACES

ENERGY CONSUMPTION VISUALIZATION COMPONENTS

FA COMPONENTS

MACHINE VISION SYSTEMS

UV CURING SYSTEMS

Selection Guide

Laser Displacement

Magnetic Displacement

Collimated Beam

Digital Panel Controller

Metal-sheet Double-feed Detection

HL-G1

HL-C2

HL-C1

**SPECIFICATIONS**

Item	Model No.	Type	Diffuse reflection type					Specular reflection type		
		Standard type	HL-G103-A-C5	HL-G105-A-C5	HL-G108-A-C5	HL-G112-A-C5	HL-G125-A-C5	HL-G103A-RA-C5	HL-G105A-RA-C5	HL-G108A-RA-C5
		High function type	HL-G103-S-J	HL-G105-S-J	HL-G108-S-J	HL-G112-S-J	HL-G125-S-J	HL-G103A-RS-J	HL-G105A-RS-J	HL-G108A-RS-J
FIBER SENSORS		Measurement center distance	30 mm 1.181 in	50 mm 1.969 in	85 mm 3.346 in	120 mm 4.724 in	250 mm 9.843 in	26.3 mm 1.035 in	47.3 mm 1.862 in	82.9 mm 3.264 in
LASER SENSORS		Measuring range	±4 mm ±0.157 in	±10 mm ±0.394 in	±20 mm ±0.787 in	±60 mm ±2.362 in	±150 mm ±5.906 in	±2 mm ±0.079 in	±5 mm ±0.197 in	±10 mm ±0.394 in
PHOTO-ELECTRIC SENSORS		Resolution	0.5 μm 0.020 mil	1.5 μm 0.059 mil	2.5 μm 0.098 mil	8 μm 0.315 mil	20 μm 0.787 mil	0.5 μm 0.020 mil	1.5 μm 0.059 mil	2.5 μm 0.098 mil
MICRO PHOTO-ELECTRIC SENSORS		Linearity	±0.1 % F.S.				±0.3 % F.S.		±0.2 % F.S.	
AREA SENSORS		Temperature characteristics	±0.08 % F.S./°C							
LIGHT CURTAINS / SAFETY COMPONENTS		Light source	Red semiconductor laser, Class 2 (Class 1 for specular reflection type) (IEC / JIS / FDA, Laser Notice No. 50) Max. output: 1 mW (0.39mW for specular reflection type) Peak emission wavelength: 655 nm 0.026 mil							
PRESSURE / FLOW SENSORS		Beam diameter (Note 2)	0.1 × 0.1 mm 0.004 × 0.004 in	0.5 × 1.0 mm 0.020 × 0.039 in	0.75 × 1.25 mm 0.030 × 0.049 in	1.0 × 1.5 mm 0.039 × 0.059 in	1.75 × 3.5 mm 0.069 × 0.138 in	0.1 × 0.1 mm 0.004 × 0.004 in		0.2 × 0.2 mm 0.008 × 0.008 in
INDUCTIVE PROXIMITY SENSORS		Receiving element	CMOS image sensor							
PARTICULAR USE SENSORS		Supply voltage	24 V DC ±10 % including ripple 0.5 V (P-P)							
SENSOR OPTIONS		Current consumption	100 mA max.							
		Sampling rate	200 μs, 500 μs, 1 ms, 2 ms							
SIMPLE WIRE-SAVING UNITS		Analog output	Voltage Output range: 0 to 10.5 V (normal) / 11 V (at alarm), Output impedance: 100 Ω							
			Current Output range: 3.2 to 20.8 mA (normal) / 21.6 mA (at alarm), Load impedance: 300 Ω max.							
WIRE-SAVING SYSTEMS		Output (OUT 1, OUT 2, OUT 3)	Judgment output or alarm output (setting selectable) NPN transistor, open-collector / PNP transistor, open-collector (selectable)							
MEASURE-MENT SENSORS			<In case of using NPN output> • Maximum sink current : 50 mA • Applied voltage : 3 to 24 V DC (between output and 0 V) • Residual voltage : 2 V or less (at 50 mA of sink current)				<In case of using PNP output> • Maximum source current : 50 mA • Residual voltage : 2.8 V or less (at 50 mA of source current)			
STATIC ELECTRICITY PREVENTION DEVICES		Output operation	Open when the output is ON.							
LASER MARKERS		Short circuit protection	Incorporated (automatic restoration)							
PLC		Output polarity setting input	NPN open collector output operates when 0 V is connected. PNP open collector output operates when 24 V DC is connected.							
HUMAN MACHINE INTERFACES		Timing input	NPN output operates when 0 V is connected and NPN is set (depending on settings). PNP output operates when external power + is connected and PNP is set (depending on settings).							
ENERGY CONSUMPTION VISUALIZATION COMPONENTS		Multi input	Zero set, zero set off, reset, memory switching, teaching, saving, and laser control according to the input time. In case NPN output is selected, function varies according to the time 0 V is connected NPN. In case PNP output is selected, function varies according to the time external power + is connected.							
FA COMPONENTS		Communications interface (high-function type only)	RS-422 or RS-485 (selectable) Baud rate: 9,600 / 19,200 / 38,400 / 115,200 / 230,400 / 460,800 / 921,600 bps Data length 8 bits, stop bit length 1 bit, without parity check, BCC check, termination code: CR							
MACHINE VISION SYSTEMS		Indicator	Laser emission Green LED (lights up during laser emission)							
			Alarm Orange LED (lights up when this product cannot measure because of insufficient or excessive light intensity)							
			Output Yellow LED × 3							
UV CURING SYSTEMS		Digital display	Red LED 5.5 digit display							
		Environmental resistance	Protection IP67 (IEC)							
			Ambient temperature -10 to +45 °C +14 to +113 °F (No dew condensation), Storage: -20 to +60 °C -4 to +140 °F (No dew condensation)							
			Ambient humidity 35 to 85 % RH, Storage: 35 to 85 % RH							
			Ambient illuminance Incandescent light: 3,000 lx or less at the light-receiving face (Note 3)							
			Ambient altitude 2,000 m 6,561 ft or less							
			Pollution degree 2							
			Insulation resistance 20 MΩ, or more, with 250 V DC megger between all supply terminals connected together and enclosure							
			Voltage withstandability 1,000 V AC one min. between all supply terminals connected together and enclosure							
Selection Guide		Vibration resistance	10 to 55 Hz (period: 1 min.) frequency, 1.5 mm 0.059 in amplitude in X,Y and Z directions for two hours each							
Laser Displacement			Shock resistance 500 m/s <sup>2</sup> acceleration (50 G approx.) in X,Y and Z directions for three times each							
Magnetic Displacement		Material	Enclosure: PBT, front cover: acrylic, cable: PVC							
Collimated Beam		Cable	Standard type: 0.1 mm <sup>2</sup> 10-core cabtyre cable, 5 m 16.404 ft long, high function type: 14-core cabtyre cable with connector, 0.5 m 1.640 ft long							
Digital Panel Controller		Cable extension	Extension up to total 20 m 65.617 ft is possible with optional cable (Cable for standard type cannot be extended).							
Metal-sheet Double-feed Detection		Weight	Standard type Net weight: 70 g approx. (not including cable), 320 g approx. (including cable), gross weight: 380 g approx.							
			High function type Net weight: 70 g approx. (not including cable), 110 g approx. (including cable), gross weight: 160 g approx.							
		Accessory	Warning label: 1 set							

- Notes: 1) Where measurement conditions have not been specified precisely, the conditions used were as follows: supply voltage 24 V DC, ambient temperature +20 °C +68 °F, sampling rate 500 μs, average number of samples: 1024, measurement center distance, object measured is made of white ceramic (specular reflection type: an aluminum vapor deposition surface reflection mirror) and analog measurement values.
- 2) This beam diameter is the size at the measurement center distance. These values were defined by using 1/e<sup>2</sup> (13.5 %) of the center light intensity. The results may be affected if there is a slight leakage of light outside the normal spot diameter and if the periphery surrounding the sensing point has a higher reflectivity than the sensing point itself.
- 3) The fluctuation by ambient illuminance is ±0.1 % F.S. or less.

## I/O CIRCUIT AND WIRING DIAGRAMS

### I/O circuit diagrams

#### When selecting NPN output

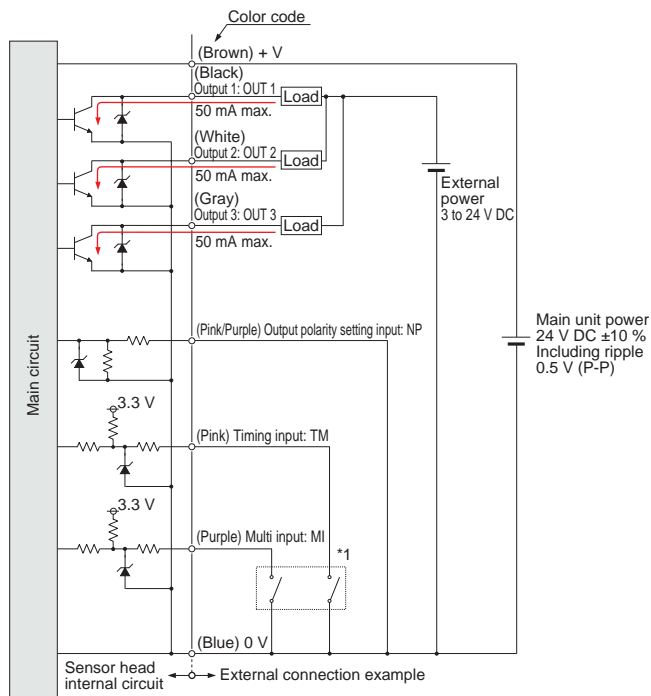

#### When selecting PNP output

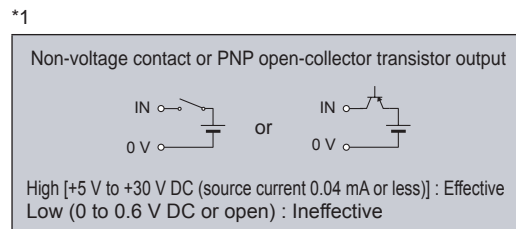
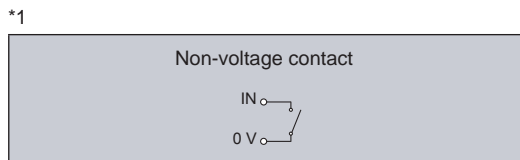
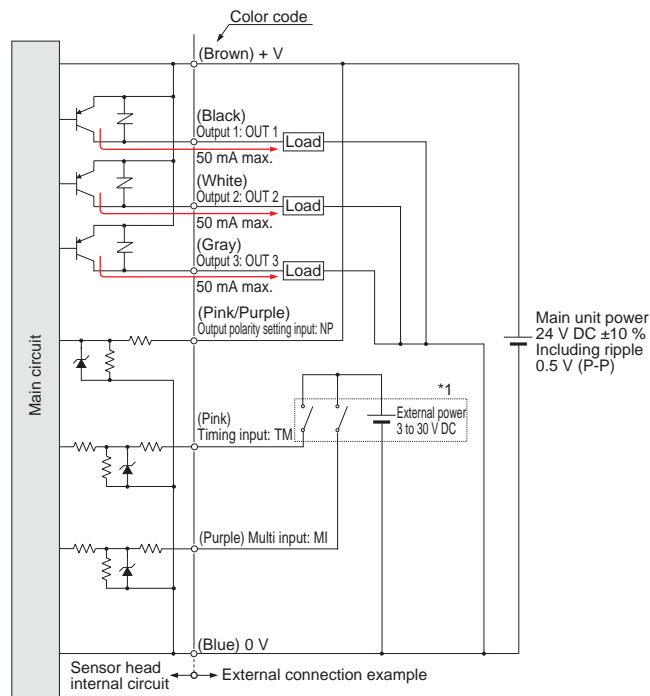

#### Analog output (common in NPN output type and PNP output type)

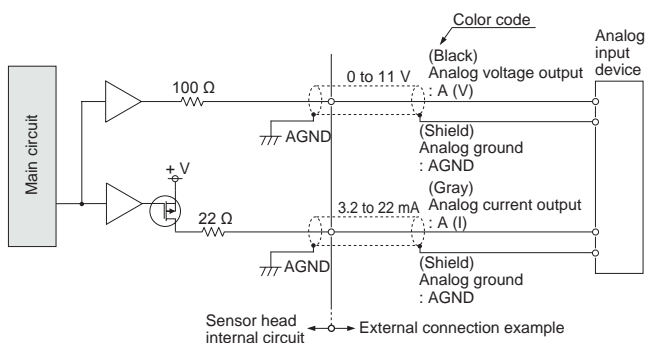

Notes: 1) Analog output is not equipped with the short-circuit protection. Do not short-circuit or apply voltage to them.  
 2) Use shielded wires for analog outputs.

FIBER SENSORS

LASER SENSORS

PHOTO-ELECTRIC SENSORS

MICRO PHOTO-ELECTRIC SENSORS

AREA SENSORS

LIGHT CURTAINS / SAFETY COMPONENTS

PRESSURE / FLOW SENSORS

INDUCTIVE PROXIMITY SENSORS

PARTICULAR USE SENSORS

SENSOR OPTIONS

SIMPLE WIRE-SAVING UNITS

WIRE-SAVING SYSTEMS

MEASURE-MENT SENSORS

STATIC ELECTRICITY PREVENTION DEVICES

LASER MARKERS

PLC

HUMAN MACHINE INTERFACES

ENERGY CONSUMPTION VISUALIZATION COMPONENTS

FA COMPONENTS

MACHINE VISION SYSTEMS

UV CURING SYSTEMS

Selection Guide

Laser Displacement

Magnetic Displacement

Collimated Beam

Digital Panel Controller

Metal-sheet Double-faced Detection

HL-G1

HL-C2

HL-C1

**I/O CIRCUIT AND WIRING DIAGRAMS**

**Communication specifications (High function type)**

Communication method	RS-422	RS-485
	Full duplex	Half duplex
Synchronization method	Asynchronous communication method	
Transmission code	ASC II	
Baud rate	9,600/19,200/38,400/115,200/230,400/460,800/921,600 bps	
Data length	8 bit	
Stop bit length	1 bit	
Parity check	None	
BCC	Yes	
Termination code	CR	

The **HL-G1** can be connected to upper devices of RS-422/485.  
When upper device sends the request command, the **HL-G1** series send the response command.

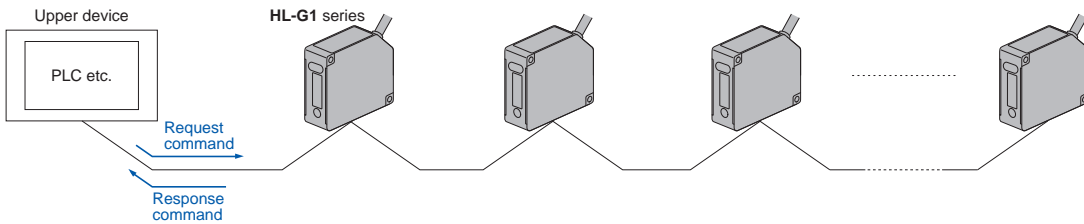

**RS-422 1-to-1 connection**

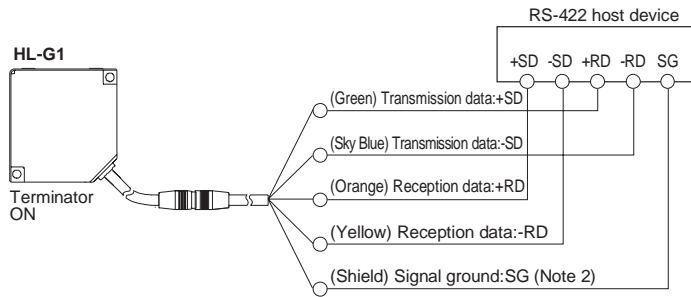

- Notes: 1) The transmission data cable and reception data cable are both twisted-pair cables.  
2) The shield is connected to the 0-V side of the power supply line inside the sensor.  
3) Be sure to connect the signal ground.  
4) The sensor is of non-isolated type. Make sure that the potential difference between the sensor and RS-422 connecting device does not exceed 4V. A difference in potential in excess may cause the connecting device or the sensor to malfunction.

**RS-485 1-to-N connection**

- Connectable up to 16 units.
- Please set the prefix with no duplication.

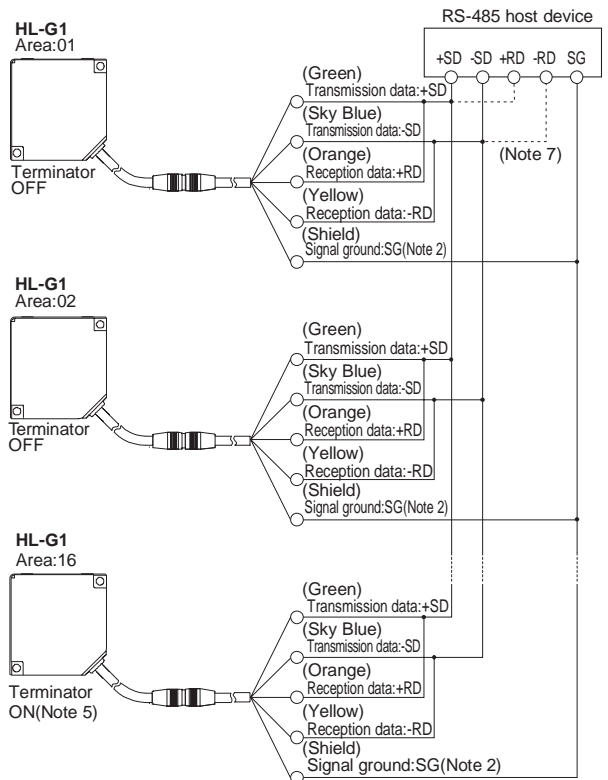

- Notes: 1) The transmission data cable and reception data cable are both twisted-pair cables.  
2) The shield is connected to the 0-V side of the power supply line inside the sensor.  
3) Be sure to connect the signal ground.  
4) The sensor is of non-isolated type. Make sure that the potential difference between the sensor and RS-485 connecting device does not exceed 4V. A difference in potential in excess may cause the connecting device or the sensor to malfunction.  
5) The sensor has a built-in terminating resistor. Be sure to turn ON the terminating resistor of the terminating sensor.  
6) Perform transition wiring for the transmission path.  
7) Connect the wires according to the specification of the equipment.

FIBER SENSORS  
LASER SENSORS  
PHOTO-ELECTRIC SENSORS  
MICRO PHOTO-ELECTRIC SENSORS  
AREA SENSORS  
LIGHT CURTAINS/ SAFETY COMPONENTS  
PRESSURE / FLOW SENSORS  
INDUCTIVE PROXIMITY SENSORS  
PARTICULAR USE SENSORS  
SENSOR OPTIONS  
SIMPLE WIRE-SAVING UNITS  
WIRE-SAVING SYSTEMS  
MEASUREMENT SENSORS  
STATIC ELECTRICITY PREVENTION DEVICES  
LASER MARKERS  
PLC  
HUMAN MACHINE INTERFACES  
ENERGY CONSUMPTION VISUALIZATION COMPONENTS  
FA COMPONENTS  
MACHINE VISION SYSTEMS  
UV CURING SYSTEMS  
Selection Guide  
Laser Displacement  
Magnetic Displacement  
Collimated Beam  
Digital Panel Controller  
Metal-sheet Double-feed Detection

**HL-G1**

**HL-C2**

**HL-C1**

**SENSING CHARACTERISTICS (TYPICAL)**

**Correlation between measuring distance and error characteristics**

**Diffuse reflection type**

White ceramic  
Vertical orientation

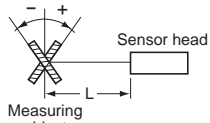

White ceramic  
Horizontal orientation

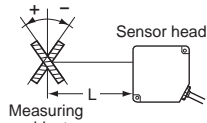

**HL-G103** Diffuse reflection type

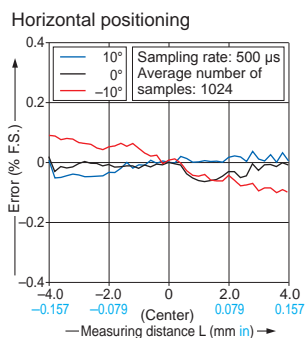
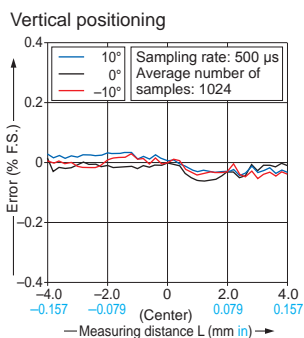

**Specular reflection type**

Aluminum vapor deposition  
surface reflection mirror  
Vertical orientation

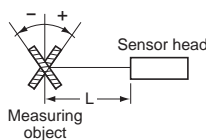

Aluminum vapor deposition  
surface reflection mirror  
Horizontal orientation

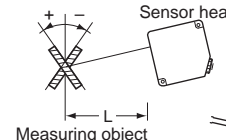

**HL-G105** Diffuse reflection type

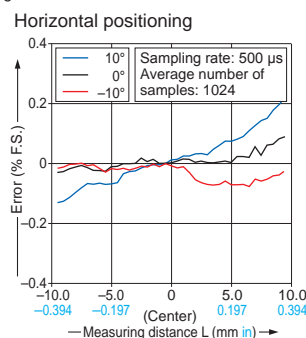
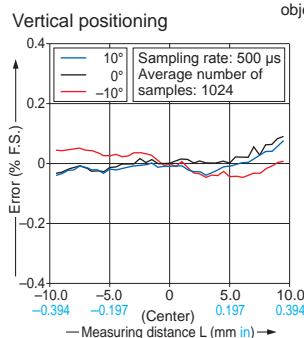

**HL-G108** Diffuse reflection type

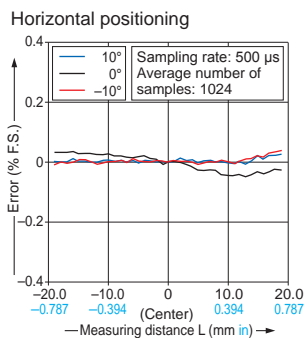
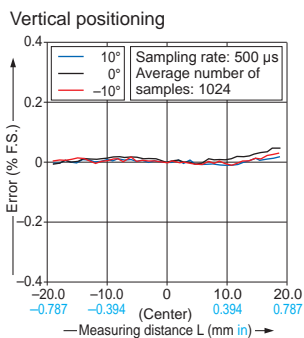

**HL-G112** Diffuse reflection type

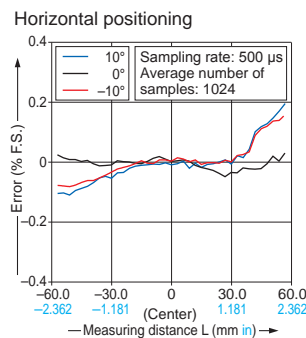
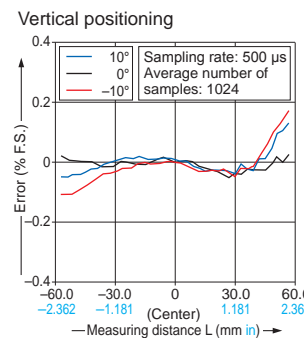

**HL-G125** Diffuse reflection type

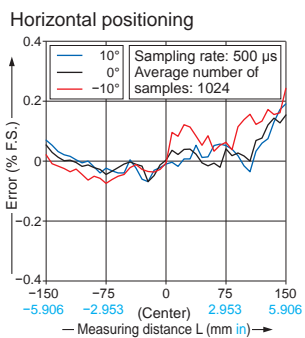
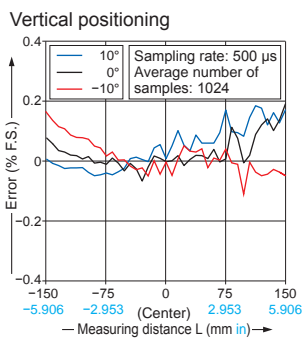

**HL-G103A-R** Specular reflection type

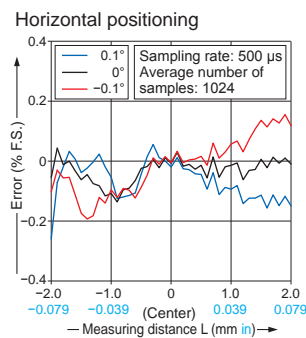
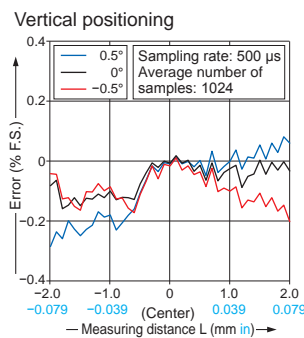

**HL-G105A-R** Specular reflection type

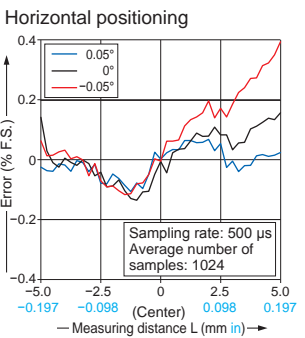
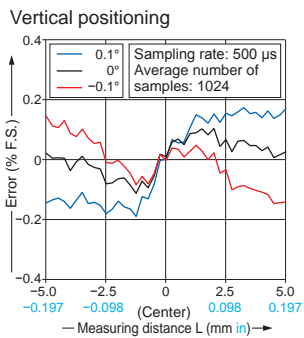

**HL-G108A-R** Specular reflection type

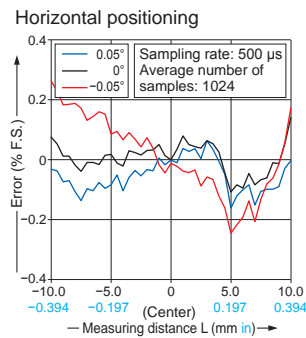
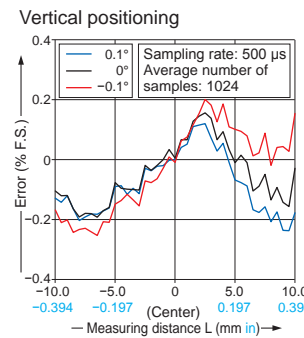

- FIBER SENSORS
- LASER SENSORS
- PHOTO-ELECTRIC SENSORS
- MICRO PHOTO-ELECTRIC SENSORS
- AREA SENSORS
- LIGHT CURTAINS / SAFETY COMPONENTS
- PRESSURE / FLOW SENSORS
- INDUCTIVE PROXIMITY SENSORS
- PARTICULAR USE SENSORS
- SENSOR OPTIONS
- SIMPLE WIRE-SAVING UNITS
- WIRE-SAVING SYSTEMS
- MEASURE-MENT SENSORS
- STATIC ELECTRICITY PREVENTION DEVICES
- LASER MARKERS
- PLC
- HUMAN MACHINE INTERFACES
- ENERGY CONSUMPTION VISUALIZATION COMPONENTS
- FA COMPONENTS
- MACHINE VISION SYSTEMS
- UV CURING SYSTEMS

- Selection Guide
- Laser Displacement
  - Magnetic Displacement
  - Collimated Beam
  - Digital Panel Controller
  - Metal-sheet Double-faced Detection

- HL-G1**
- HL-C2**
- HL-C1**

- FIBER SENSORS
- LASER SENSORS
- PHOTO-ELECTRIC SENSORS
- MICRO PHOTO-ELECTRIC SENSORS
- AREA SENSORS
- LIGHT CURTAINS/SAFETY COMPONENTS
- PRESSURE / FLOW SENSORS
- INDUCTIVE PROXIMITY SENSORS
- PARTICULAR USE SENSORS
- SENSOR OPTIONS
- SIMPLE WIRE-SAVING UNITS
- WIRE-SAVING SYSTEMS
- MEASUREMENT SENSORS
- STATIC ELECTRICITY PREVENTION DEVICES
- LASER MARKERS
- PLC
- HUMAN MACHINE INTERFACES
- ENERGY CONSUMPTION VISUALIZATION COMPONENTS
- FA COMPONENTS
- MACHINE VISION SYSTEMS
- UV CURRING SYSTEMS

## PRECAUTIONS FOR PROPER USE

Refer to p.1501 for general precautions and p.1499~ for information about laser beam.



- Never use this product as a sensing device for personnel protection.
- In case of using sensing devices for personnel protection, use products which meet laws and standards, such as OSHA, ANSI or IEC etc., for personnel protection applicable in each region or country.
- This product has been developed / produced for industrial use.



- Do not operate products using methods other than the ones described in the instruction manual included with each product. Control or adjustment through procedures other than the ones specified may cause hazardous laser radiation exposure.
- The following label is attached to the product. Handle the product according to the instruction given on the warning label. (The Japanese, English, Chinese, Korean warning label is packed with the sensor.)

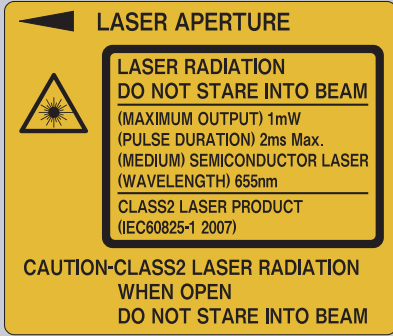



- This product is classified as a Class 2 (specular reflection type: Class 1) Laser Product in IEC / JIS standards and FDA\* regulations. Do not look at the laser beam directly or through optical system such as a lens.

\*This product complies with 21 CFR 1040.10 and 1040.11 Laser Notice No. 50, dated June 24, 2007, issued by CDRH (Center for Devices and Radiological Health) under the FDA (Food and Drug Administration).

### Beam diameter (Unit: mm in)

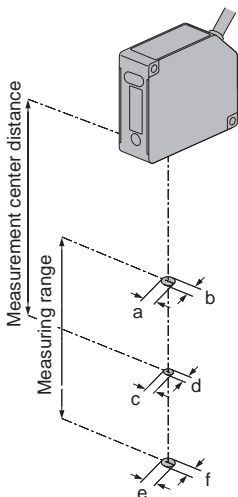
#### Diffuse reflection type



Model No.	Beam diameter					
	a	b	c	d	e	f
HL-G103-S-J	0.15	0.15	0.1	0.1	0.15	0.15
HL-G103-A-C5	0.006	0.006	0.004	0.004	0.006	0.006
HL-G105-S-J	1.2	0.6	1.0	0.5	0.9	0.4
HL-G105-A-C5	0.047	0.024	0.039	0.020	0.035	0.016
HL-G108-S-J	1.5	0.9	1.25	0.75	1.0	0.6
HL-G108-A-C5	0.059	0.030	0.049	0.030	0.039	0.024
HL-G112-S-J	1.8	1.2	1.5	1.0	0.8	0.5
HL-G112-A-C5	0.071	0.047	0.059	0.039	0.031	0.020
HL-G125-S-J	2.5	1.5	3.5	1.75	4.5	2.0
HL-G125-A-C5	0.098	0.059	0.138	0.069	0.177	0.079

#### Specular reflection type

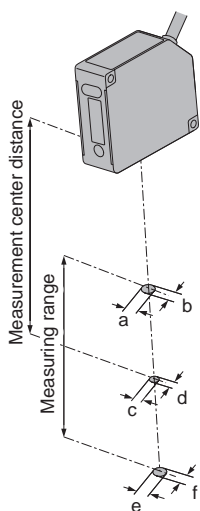

Model No.	Beam diameter					
	a	b	c	d	e	f
HL-G103-RS-J	0.15	0.15	0.1	0.1	0.15	0.15
HL-G103-RA-C5	0.006	0.006	0.004	0.004	0.006	0.006
HL-G105-RS-J	0.15	0.15	0.1	0.1	0.15	0.15
HL-G105-RA-C5	0.006	0.006	0.004	0.004	0.006	0.006
HL-G108-RS-J	0.2	0.2	0.2	0.2	0.2	0.2
HL-G108-RA-C5	0.008	0.008	0.008	0.008	0.008	0.008

- Selection Guide
- Laser Displacement
- Magnetic Displacement
- Collimated Beam
- Digital Panel Controller
- Metal-sheet Double-feed Detection
- HL-G1
- HL-C2
- HL-C1

## PRECAUTIONS FOR PROPER USE

Refer to p.1501 for general precautions and p.1499~ for information about laser beam.

### Sensor head mounting direction

- To obtain the greatest precision, the sensor head should be oriented facing the direction of movement of the object's surface, as shown in the figure below.

#### Object with variations in material or color

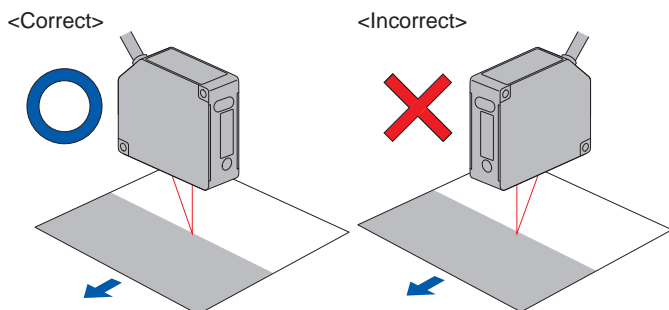

#### Rotating object

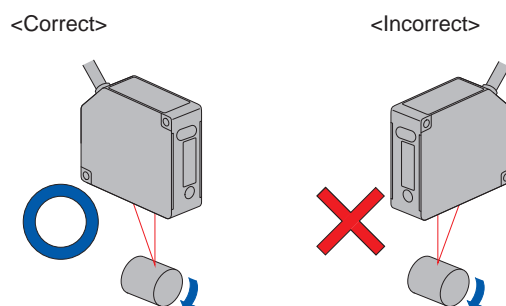

#### Object that has large differences in gaps, grooves and colors

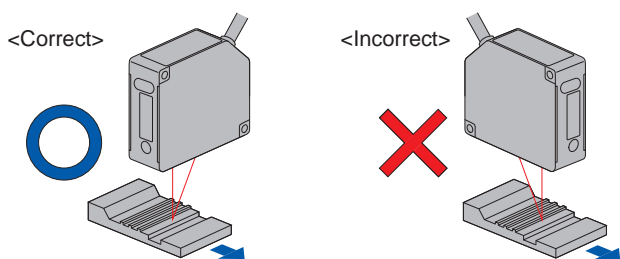

## DIMENSIONS (Unit: mm in)

The CAD data in the dimensions can be downloaded from our website.

HL-G1□-A-C5 HL-G1□-S-J

Sensor head

Model No.	Measurement center distance (ℓ)	θ
HL-G103-A-C5 HL-G103-S-J	30 mm 1.181 in	30°
HL-G105-A-C5 HL-G105-S-J	50 mm 1.969 in	21°
HL-G108-A-C5 HL-G108-S-J	85 mm 3.346 in	15°
HL-G112-A-C5 HL-G112-S-J	120 mm 4.724 in	11°
HL-G125-A-C5 HL-G125-S-J	250 mm 9.843 in	6.2°

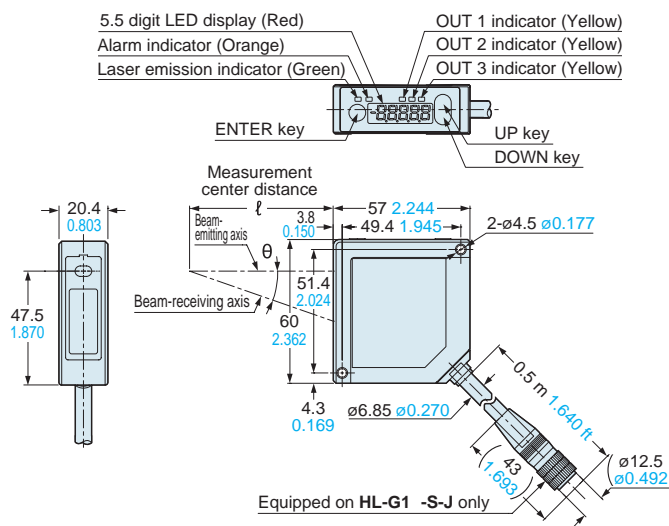

FIBER SENSORS

LASER SENSORS

PHOTO-ELECTRIC SENSORS

MICRO PHOTO-ELECTRIC SENSORS

AREA SENSORS

LIGHT CURTAINS / SAFETY COMPONENTS

PRESSURE / FLOW SENSORS

INDUCTIVE PROXIMITY SENSORS

PARTICULAR USE SENSORS

SENSOR OPTIONS

SIMPLE WIRE-SAVING UNITS

WIRE-SAVING SYSTEMS

MEASUREMENT SENSORS

STATIC ELECTRICITY PREVENTION DEVICES

LASER MARKERS

PLC

HUMAN MACHINE INTERFACES

ENERGY CONSUMPTION VISUALIZATION COMPONENTS

FA COMPONENTS

MACHINE VISION SYSTEMS

UV CURING SYSTEMS

Selection Guide

Laser Displacement

Magnetic Displacement

Collimated Beam

Digital Panel Controller

Metal-sheet Double-head Detection

HL-G1

HL-C2

HL-C1

**DIMENSIONS (Unit: mm in)**

The CAD data in the dimensions can be downloaded from our website.

**HL-G103A-RA-C5 HL-G103A-RS-J** Sensor head

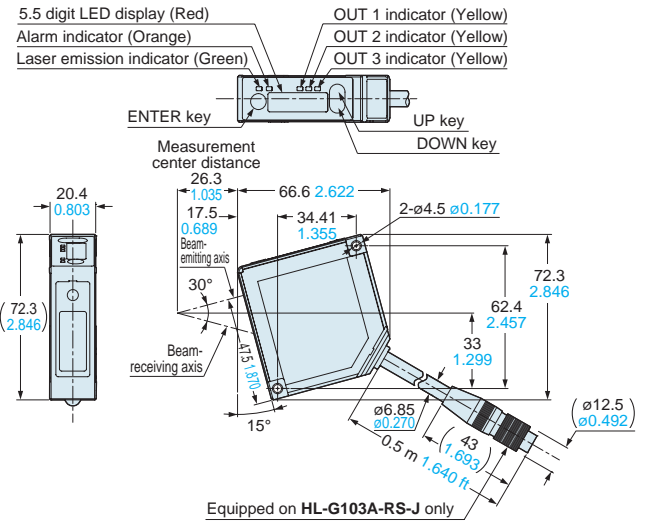

**HL-G105A-RA-C5 HL-G105A-RS-J** Sensor head

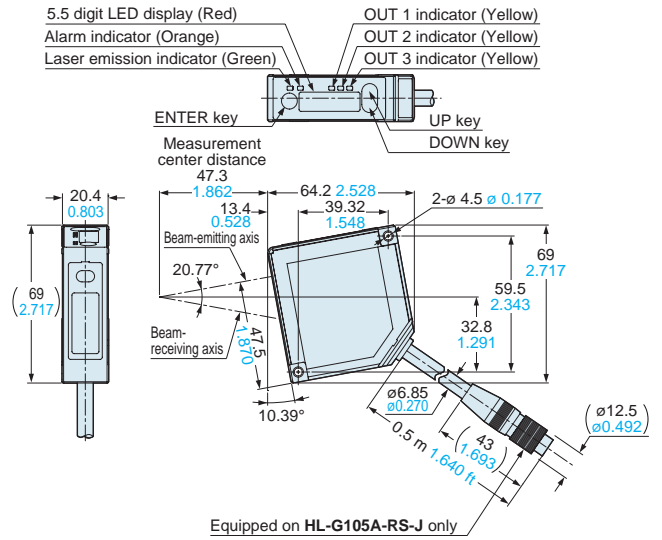

**HL-G108A-RA-C5 HL-G108A-RS-J** Sensor head

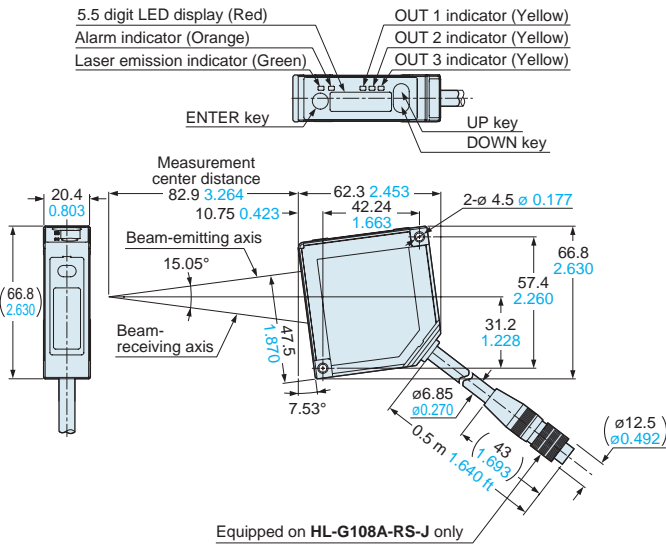

**HL-G1CCJ** Extension cable (Optional)

Model No.	L
HL-G1CCJ2	2,000 <sup>+200</sup> <sub>0</sub> 78.740 <sup>+7.874</sup> <sub>0</sub>
HL-G1CCJ5	5,000 <sup>+500</sup> <sub>0</sub> 196.850 <sup>+19.685</sup> <sub>0</sub>
HL-G1CCJ10	10,000 <sup>+1,000</sup> <sub>0</sub> 393.701 <sup>+39.370</sup> <sub>0</sub>
HL-G1CCJ20	20,000 <sup>+2,000</sup> <sub>0</sub> 787.402 <sup>+78.740</sup> <sub>0</sub>

