

ECLIPSE

StoneL's ECLIPSE features dual solid state sensors with optional communications neatly integrated into a sealed module. The function module and trigger/indicator attach quickly and conveniently to standard VDI/VDE 3845 (Namur) actuator accessory mounting pads.

The ECLIPSE series is available in nonincendive and intrinsically safe versions (EN) for hazardous areas with a removable module and in a general purpose completely sealed micro-connector version (EG).

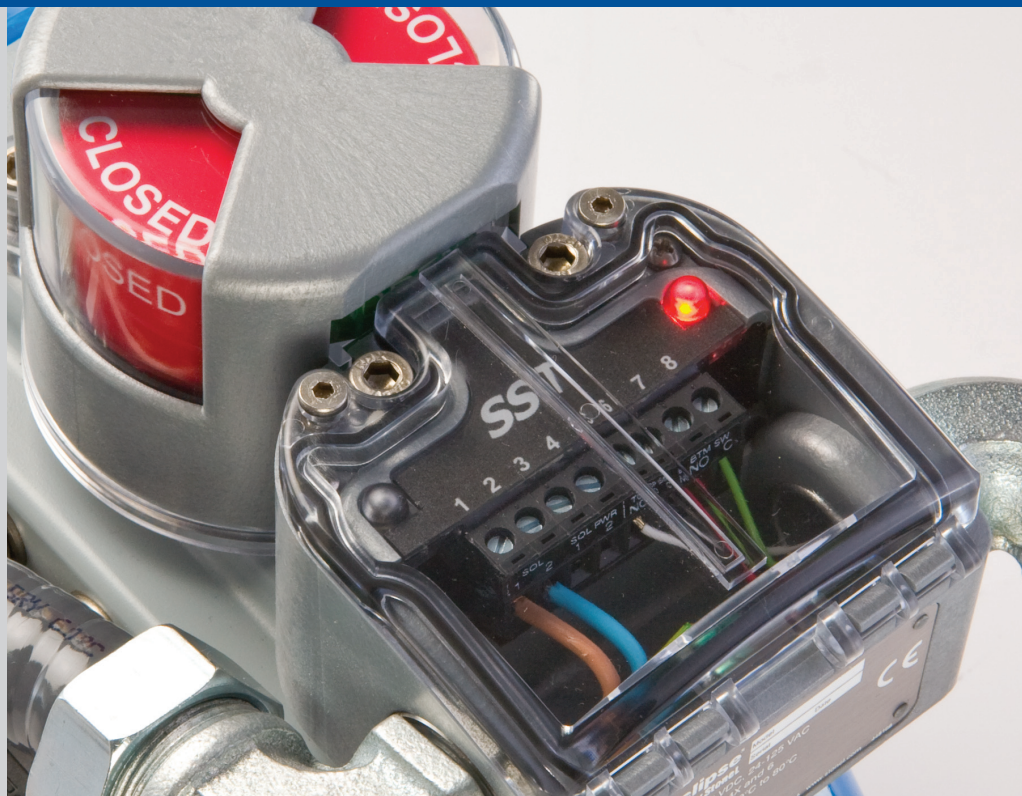

Feature Rich Design Offers Incredible Value

- Position sensors, communication electronics and power outputs for solenoids are integrated into an extremely compact, rugged enclosure.
- Red/Green visual indicator boldly displays valve status, and coordinates with Red/Green LEDs.
- Fully submersible and capable of high pressure wash down.
- ECLIPSE sensors and electronics are fully sealed to eliminate hazard threat and corrosion problems.
- Direct attachment to ISO/Namur mounting pads.
- High intensity red and green LEDs indicate electronic switch status to confirm electrical operation.
- Sensor triggers are adjustable in 3.5 degree increments through 360 degrees for precision and flexibility.
- All mechanical parts are made of Lexan® or stainless steel for corrosion resistance and durability.
- No moving mating parts assure long life and trouble-free operation.

EN: The Ultimate in Convenience, Reliability and Cost Effectiveness in Class I, Div. 2 Areas

- Suitable for all hazardous areas.
- Rated for NEMA 4, 4X, 6 (intrinsically safe and nonincendive approved: IP67).
- Additional termination points and dual conduit entries eliminate junction boxes for solenoid valve termination.
- Convenient wiring compartment and pre-labeled terminal strip enables rapid installation.



Triggering & Visual Indicator



Red/Green option



Flow line option

Red and green visual indication is viewable from 360 degrees around the automated valve and from above at distances up to 70 feet. The yellow flow line indicator is also available, which is viewable from all angles at a distance up to 30 feet.

ECLIPSE solid state inductive sensors are activated by stainless steel targets embedded into the visual indicator drum. Open and Closed targets may be independently adjusted in 3.5 degree increments.

EG: Convenient Micro-Connector Wiring

- Available with additional built in connector for solenoid termination.
- Micro-connectors with potted and sealed enclosure eliminate any threat of moisture contamination in wiring.
- Electronic module integrated permanently into enclosure.



Sensing, Communication and Visual Indication

The ECLIPSE offers incredible value and space efficiency. Communications, position sensing, power outputs and auxiliary inputs are sealed in the ECLIPSE function module. Select from Namur sensors, SST switching sensors, or AS-Interface, DeviceNet, or Modbus communication terminals. All are fully solid state and sealed.

(For more detailed information please see pages 28 through 34.)

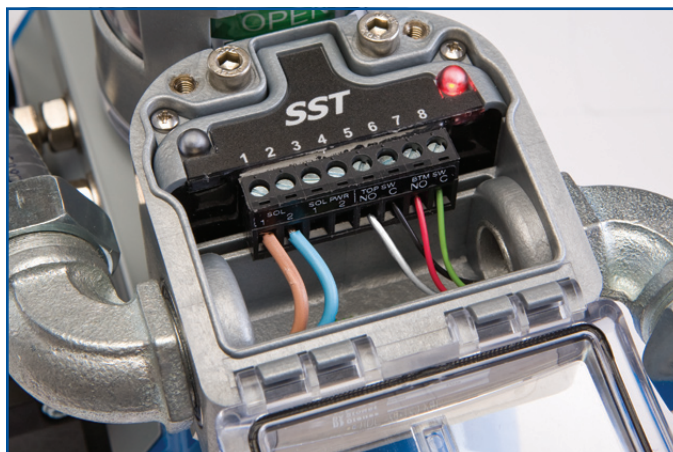

ECLIPSE

MODBUS DeviceNet.

SST Switching Sensors (33)

Configuration	(2) SST Switching Sensors (2) Wire Terminations for one Solenoid
Output	Select either NO (33) or NC (34) Models
Maximum Current	
Inrush	2.0 Amps
Continuous	0.3 Amps
Min. On Current	2.0 mA
Max. Leakage Current	0.5 mA
Voltage Range	8 to 125VDC / 24 to 125VAC
Max. Voltage Drop	7.0 Volts @ 100 mA

Namur Sensors (44)

Configuration	(2) NAMUR Sensors (2) Wire Terminations for one Solenoid
Output	Conforms to EN 60947-5-6
Current Ratings	Target On <1.0 mA Target Off >3.0 mA
Voltage Range	5 to 25 VDC

AS-Interface VCT (96)

Configuration	(2) Sensor Inputs (2) Auxiliary Inputs (2) Power Outputs (Solenoids)
Max. Current	160mA, Both Outputs Combined (Current Limited to 200mA)
Outputs, Max. Power	4 Watts, Both Outputs Combined
Outputs, Voltage	25 to 30 VDC

AS-Interface VCT (97) with Extended Addressing

Configuration	(2) Sensor Inputs (2) Auxiliary Discrete Inputs (1) Power Output (Solenoid)
Max. Current	100mA
Outputs, Max. Power	2.4 Watts
Outputs, Voltage	25 to 30 VDC

DeviceNet VCT (92)

Configuration	(2) Discrete Inputs (Open & Closed) (2) Power Outputs (Solenoids) (1) 4-20 mA Auxiliary Input
Outputs, Max. Power	4 Watts, Both Outputs Combined
Outputs, Voltage	24 VDC

Modbus VCT (95)

Configuration	(2) Discrete Inputs (Open and Closed) (2) Power Outputs (Solenoids) (1) 4-20mA Auxiliary Input
Outputs	4 watts @ 24 VDC Both Outputs Combined (Current Limited to 200mA)
Devices per Network	32
Other Features	Pre-determined Output Fail State

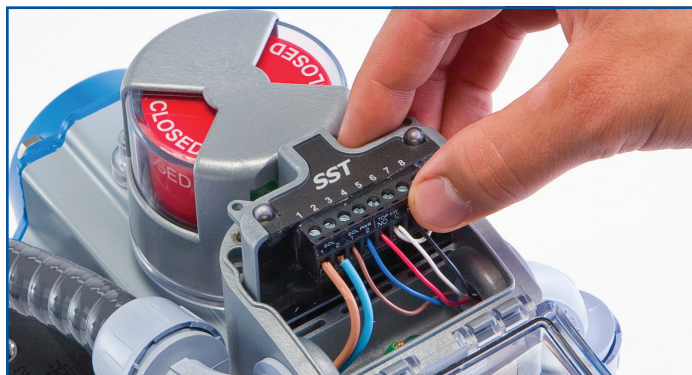

EN features a removable, fully sealed dual module to facilitate quick, convenient maintenance and wiring.

Nonincendive & Intrinsically Safe Model Selector

Model Example: EN92C02RA

	Function	Enclosure	Conduit/Connectors	Visual Indicator
EN	Sensor/Switching Modules 33 (2) SST N.O. Sensors 34 (2) SST N.C. Sensors Intrinsically Safe Models 44 (2) Namur Sensors (EN 60947-5-6) (available with conduit/connector options 02, 05, or 11) Valve Communication Terminals (VCT) 92 DeviceNet 95 Modbus 96 AS-Interface 97 AS-Interface with Extended Addressing	C North American (NEC/CEC) D International (IEC)	02 (2) 1/2" NPT Conduit Entry 05 (2) M20 Conduit Entry 11 (1) 5-Pin Mini Connector 12 (1) 5-Pin Mini and (1) 3-Pin Mini Connector *Consult factory for additional quick connector options	RA Red Closed Flow Line FA T-1 3-Way (90° rotation) 1A T-2 3-Way (90° rotation) 2A T-2 3-Way (90° rotation) XA Special See Visual Indications Designations chart on page 15

General Purpose Model Selector

Model Example: EG96C23FA

	Function	Enclosure	Connectors	Visual Indicator
EG	Sensor/Switching Modules 33 (2) SST N.O. Sensors (available with connector options 23 or 26) 34 (2) SST N.C. Sensors (available with connector options 23 or 26) Intrinsically Safe Modules 44 Namur Sensors (EN 60947-5-6) (available with connector option 23 only) Valve Communication Terminals (VCT) 92 DeviceNet (available with connector options 25 or 26) 95 Modbus (available with connector options 25 or 26) 96 AS-Interface (available with connector options 23 or 24) 97 AS-Interface with Extended Addressing (available with connector options 23 or 24)	C General Purpose, Universal	23 (1) 4-Pin Micro Connector, Metallic 24 (2) 4-Pin Micro Connectors, Metallic 25 (1) 5-Pin Micro Connector, Metallic 26 (1) 5-Pin and (1) 4-Pin Micro Connector, Metallic	RA Red Closed Flow Line FA T-1 3-Way (90° rotation) 1A T-2 3-Way (90° rotation) 2A T-2 3-Way (90° rotation) XA Special See Visual Indications Designations chart on page 15

ECLIPSE Mounting (Required for all ECLIPSE and sold separately)

- | | |
|--|--|
| <p>960701 Namur Sizes 1 and 2</p> <p>960710 Namur Size 3</p> <p>960704 Namur Size 4</p> <p>950714 Jamesbury VPVL 051, 100</p> <p>950712 Jamesbury VPVL 200, 300 (includes bracket)</p> <p>795702 Jamesbury VPVL 350 to 500</p> <p>795703 Jamesbury VPVL 550 to 800</p> <p>Consult factory for other non-Namur applications.</p> | <ul style="list-style-type: none"> • Kits conform to standard ISO/NAMUR actuator patterns. • All kits stainless steel. • Namur size 3 kit 960710 fit all shaft sizes. |
|--|--|

Other Specifications and Ratings

Materials of Construction

Housing	Lexan® Polycarbonate
Drum Components	Lexan® Polycarbonate
Fasteners	Stainless Steel
Triggers and Coupling	Stainless Steel

Temperature Range -40° C to 80° C (-40° F to 176° F)

Operating Life Unlimited

Warranty

Dual Module	Five Years
Mechanical Components	Two Years

Lexan® is a registered trademark of General Electric Corporation.

Nonincendive Ratings

EN Models

NEC/CEC	Class I Division 2 Groups A, B, C, D Class II Division 2 Groups F, G
IEC	Ex nA IIC T5, Zone 2

Intrinsically Safe Ratings

EN 44 Models only

NEC/CEC	Class I Divisions 1 and 2 Groups A, B, C, D Class II Divisions 1 and 2 Groups E, F, G
IEC	Ex ia IIC T5, Zones 0,1, & 2

Enclosure Ratings

EN and EG Models

NEC/CEC	4, 4X & 6C
IEC	IP67

For approval information visit www.stonel.com/approvals

Dimensions

Inches [mm]

ECLIPSE EN

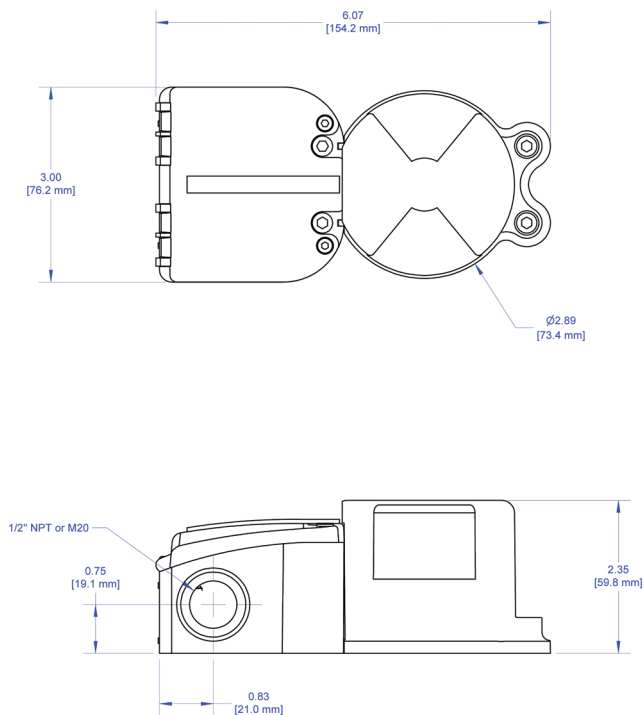

ECLIPSE EG

