



GE Magnetic Contacts

1085T Series

Surface Mount with Screw Terminals



Gap Distance	Closed Loop	SPDT
Regular 3/4"	1085T	1087T
Wide 1 1/2"	1085TW	1087TW
Extra Wide 2"		1084TW

Color	White, Mahogany Brown, Grey
Quantity	10

100% **TESTED**



1085T-N

1085T Series

Surface Mount with Screw Terminals

Installation Instructions

- 1084TW, 1085T, 1085TW, 1087T, 1087TW** Select desired mounting positions for contact and magnet. On wide gap contacts (those with W suffix) align labels on contact and magnet so labels read in the same direction (switches are polarity sensitive). Attach with screws.
- General** If protective cover is to be used to shield screw terminals, allow space for "ears" of cover before tightening down mounting screws. Route connecting wires through holes provided in cover.

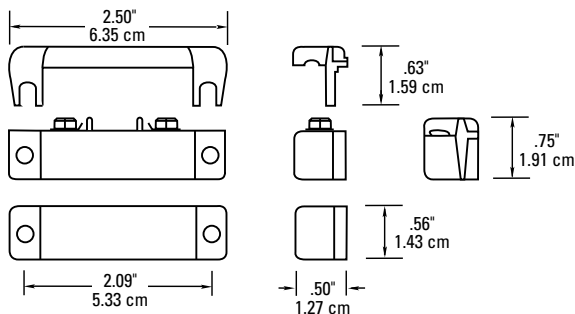

UL Specifications

Part Number	Loop Type	Electrical Configuration	Gap Distance*
1084TW	Open or Closed	SPDT	2"
1085T	Closed	N.O.	3/4"
1085TW	Closed	N.O.	1 1/2"
1087T	Open or Closed	SPDT	3/4"
1087TW	Open or Closed	SPDT	1 1/2"

* Gap Specifications are nominal and may vary $\pm 20\%$. Gap Specifications are for switch to make. Break distance is approximately 1.1 to 1.5 times make.

** European Union Specifications: 48 V AC/DC max, 0.5 Amp

** FORM A (1085T, 1085TW)

Voltage: 100 V AC/DC max
Current: 0.5 A max
Power: 7.5 W max

** FORM C (1084TW, 1087T, 1087TW)

Voltage: 30 V AC/DC max
Current: 0.25 A max
Power: 3.0 W max

WARNING: Each electrical rating is an individual maximum and cannot be exceeded!

C-UL Specifications

All Contacts: 30 VDC, 50 mA max

Gap Specifications:
See UL Gap Specifications

