



Watts Air Preparation Systems & Accessories

QUBE, General Line, QIX, Miniature, Stainless, Injection Lubricators & Accessories

Catalog 0305-2

aerospace
climate control
electromechanical
filtration
fluid & gas handling
hydraulics
pneumatics
process control
sealing & shielding



ENGINEERING YOUR SUCCESS.

Notes & Caution

 WARNING

FAILURE OR IMPROPER SELECTION OR IMPROPER USE OF THE PRODUCTS AND/OR SYSTEMS DESCRIBED HEREIN OR RELATED ITEMS CAN CAUSE DEATH, PERSONAL INJURY AND PROPERTY DAMAGE.

This document and other information from Parker Hannifin Corporation, its subsidiaries and authorized distributors provide product and/or system options for further investigation by users having technical expertise. It is important that you analyze all aspects of your application including consequences of any failure, and review the information concerning the product or system in the current product catalog. Due to the variety of operating conditions and applications for these products or systems, the user, through its own analysis and testing, is solely responsible for making the final selection of the products and systems and assuring that all performance, safety and warning requirements of the application are met.

The products described herein, including without limitation, product features, specifications, designs, availability and pricing, are subject to change by Parker Hannifin Corporation and its subsidiaries at any time without notice.

Offer of Sale

The items described in this document are hereby offered for sale by Parker Hannifin Corporation, its subsidiaries or its authorized distributors. This offer and its acceptance are governed by the provisions stated on the separate page of this document entitled "Offer of Sale".

© Copyright 2008, 2001 Parker Hannifin Corporation. All Rights Reserved



Pneumatic Division
Richland, Michigan
www.wattsfluidair.com

Buy: www.ValinOnline.com | Phone: 800-774-5630 | Email: CustomerService@valin.com

Table of Contents

QUBE Modular FRL System	A QUBE
Air Preparation Units	B Air Preparation Units
Miniature FRLs	C Miniature FRLs
Stainless Steel FRLs	D Stainless Steel FRLs
Injection Lubricators	E Injection Lubricators
Accessories	F Accessories
Safety Guide, Offer of Sale	G Safety Guide, Offer of Sale

*General Line, QIX, High Efficiency Filters,
Dial & Precision Regulators*

*Flow Controls & Accessories, Control
Panel Products, Sensing, "LV" / "EZ",
Ball Valves / Plug Valves / Drain Cocks,
Safety Blow Guns, Fittings & Hose,
Fittings & Tubing, Quick Couplings*





Pneumatic Products

Airline Accessories

Section F



Flow Controls & Accessories.....	F5
Control Panel Products (Human / Machine Dialog).....	F35
Sensing (Pneumatic Control Components).....	F51
“LV” / “EZ” (Lockout Valves).....	F69
Ball Valves / Plug Valves / Drain Cocks.....	F75
Safety Blow Guns.....	F89
Fittings & Hose.....	F95
Fittings & Tubing.....	F107
Hose.....	F189
Quick Couplings.....	F209



AIR PREPARATION UNITS

Symbol	Description
	FILTER / SEPARATOR with manual drain
	FILTER / SEPARATOR with automatic drain
	OIL REMOVAL FILTER
	AUTOMATIC DRAIN
	LUBRICATOR less drain
	LUBRICATOR with manual drain
	LUBRICATOR with automatic filling
	AIR LINE PRESSURE REGULATOR adjustable, relieving
	AIR LINE PRESSURE REGULATOR pilot controlled, relieving
	FILTER / REGULATOR (piggyback) Manual Drain Relieving (With Gauge)
	FILTER / REGULATOR (piggyback) Auto Drain Relieving
	AIR LINE COMBO F-R-L simplified

PNEUMATIC VALVES

Symbol	Description
	CHECK
	FLOW CONTROL
	RELIEF VALVE

PNEUMATIC VALVES (Cont'd)

Symbol	Description
	2-POSITION 2-WAY
	2-POSITION 3-WAY
	2-POSITION 4-WAY
	2-POSITION, 4-WAY 5-PORTED
	3-POSITION, 4-WAY, APB ports closed, center pos.
	3-POSITION, 4-WAY, CE 5-PORTED cylinder ports open to exhaust in center position
	3-POSITION, 4-WAY, PC 5-PORTED pressure ports open to exhaust in center position
	QUICK EXHAUST
	SHUTTLE

VALVE ACTUATORS

Symbol	Description
	MANUAL general symbol
	PUSH BUTTON
	LEVER
	PEDAL OR TREADLE
	MECHANICAL cam, toggle, etc.
	SPRING
	DETENT line indicates which detent is in use

VALVE ACTUATORS (Cont'd)

Symbol	Description
	SOLENOID
	INTERNAL PILOT SUPPLY
	REMOTE PILOT SUPPLY
	complete simplified
	AND / OR COMPOSITE solenoid and pilot or manual override
	AND / OR COMPOSITE solenoid and pilot or manual override and pilot

LINES AND FUNCTIONS

Symbol	Description
	solid line – MAIN LINE
	dashed line – PILOT LINE
	dotted line – EXHAUST OR DRAIN LINE
	center line – ENCLOSURE OUTLINE
	LINES CROSSING (90° intersection not necessary)
	LINES JOINING (90° intersection not necessary)
	LINES JOINING
	FLOW DIRECTION hydraulic medium
	FLOW DIRECTION gaseous medium
	ENERGY SOURCE
	LINE WITH FIXED RESTRICTION
	LINE WITH ADJUSTABLE RESTRICTION
	FLEXIBLE LINE
	PLUGGED PORT, TEST STATION, POWER TAKE-OFF
	QUICK DISCONNECT WITHOUT CHECKS
	QUICK DISCONNECT WITH CHECKS
	QUICK DISCONNECT WITH ONE CHECK

F



Saving Money and Space by Sizing Your Valves Properly

This catalog gives you a flow rating (Cv) for each valve in the Parker Hannifin line. You can “plug” your requirements into the following simple formula, and determine the Cv needed to do the job. By not oversizing, you’ll save space and money, and you’ll ensure the valve you select will do the job.

Converting the Job Requirements Into Cv
(Capacity Co-efficient).

$$Cv = \frac{\text{Cylinder Area (Sq. In.)} \times \text{Cylinder Stroke (In.)} \times \text{Compression Factor (Table 2)} \times \text{“A” (Table 2)}}{\text{Stroke Time (sec.)} \times 28.8}$$

Let’s work through an example:

We want to extend a 3 1/4" bore cylinder which has a 12" stroke in one second, and we have a supply pressure of 80 PSI to do the work. Here’s what we know:

- Cylinder Area for a 3-1/4" Bore, from Table 1 8.30 sq. in.
- Cylinder Stroke 12 in.
- Stroke Time Required in Seconds 1 sec.
- Compression Factor at 80 PSI, from Table 2 6.4
- “A” Constant for 80 PSI, from Table 2048

Substituting in the formula, we have:

$$Cv = \frac{8.30 \times 12 \times 6.4 \times .048}{1 \times 28.8} = 1.06$$

Any valve, therefore, which has a Cv of *at least* 1.06, will extend our cylinder the specified distance in the required time.

Choosing the Valve “Series”

Your next step is to choose a basic valve design to do the job. For a quick guide to valve designs, see Table 3.

Having selected the basic valve design, consult the Capacity Co-efficient (Cv) tables which describe the individual valve capacities.

Selecting the Valve Model, Options and Accessories

Having determined Cv, series, port size, flow-path configuration (pre-determined by circuit design), and actuation method, you’re ready to choose the *exact* valve model number.

Read the pertinent catalog pages; note the exact model numbers, options and accessories you want. Then phone or write your Parker Hannifin air valve distributor. They will give you prompt, accurate service.

Note: Need circuit design help? Contact your local Parker Hannifin distributor. They are backed up by our regional Sales Engineers and offices. Between them, you’ll find answers to all of your questions.

Table 1

Effective Square-Inch Areas for Standard-Bore-Size Cylinders

Bore Size	Cylinder Area (Sq. In.)	Bore Size	Cylinder Area (Sq. In.)
3/4"	.44	4"	12.57
1"	.79	4-1/2"	15.90
1-1/8"	.99	5"	19.64
1-1/4"	1.23	6"	28.27
1-1/2"	1.77	7"	38.48
1-3/4"	2.41	8"	50.27
2"	3.14	10"	78.54
2-1/2"	4.91	12"	113.10
3-1/4"	8.30	14"	153.94
3-5/8"	10.32		

Table 2

Compression Factors and “A” Constants

Inlet Pressure (PSIG)	Compression Factor	“A” Constants for Various Pressure Drop*		
		2 PSI ΔP	5 PSI ΔP	10 PSI ΔP
10	1.6	.152	.103	—
20	2.3	.126	.084	.065
30	3.0	.111	.073	.055
40	3.7	.100	.065	.048
50	4.4	.091	.059	.044
60	5.1	.085	.055	.040
70	5.7	.079	.051	.037
80	6.4	.075	.048	.035
90	7.1	.071	.046	.033
100	7.8	.068	.044	.032
110	8.5	.065	.042	.030
120	9.2	.063	.040	.029
130	9.9	.061	.039	.028
140	10.6	.058	.037	.027
150	11.2	.057	.036	.026
160	11.9	.055	.035	.025
170	12.6	.053	.034	.024
180	13.3	.052	.033	.024
190	14.0	.051	.032	.023
200	14.7	.050	.032	.023

Note: Use “A” constant at 5 PSI ΔP for most applications. On very critical applications, use “A” at 2 PSI ΔP. You will find in many cases, a 10 PSI ΔP is not detrimental, and can save money and mounting space.

* Tabulated values are the solution of $\frac{1}{22.48} \sqrt{\frac{GT}{(P_1 - P_2) P_2}}$ where T is for 68°F and G = 1 for Air.

Table 3

Characteristics of the Major Valve Designs

<p>A. Poppet 3-Way and 4-Way</p>	<ol style="list-style-type: none"> High flow capacities Minimum lubrication requirements Fast response Self-cleaning poppet seats Pressures of 15 to 150 PSIG (modifications for vacuum to 250 PSIG)
<p>B. Spool Valves (WCS) 3-Way and 4-Way</p>	<ol style="list-style-type: none"> Low friction Lower operating pressures Fast response Less wear Long Cycle Life - Under pressure, radial expansion of the seal occurs to maintain sealing contact with the valve bore Non-Lube Service - No lubrication required for continuous valve shifting Bi-Directional Spool Seals - Common spool used for any pressure, including vacuum
<p>C. Packed Bore 4-Way</p>	<ol style="list-style-type: none"> Wide range of flow capacities Wide range of flow-path configurations Pilot-operated models available Pressures of vacuum to 150 PSIG
<p>D. Rotary Or Reciprocating Disc 4-Way, manually operated</p>	<ol style="list-style-type: none"> Inexpensive Versatility in manual actuation

Cv – Capacity Co-efficients (sometimes called Flow Factors). Each flow path through the valve has its own Cv value. All Cv ratings for each valve cataloged on this page are listed on the front side of this sheet.

Q = Flow in Standard Cubic Feet per minute (14.7 PSIA at 60°F)
 $Cv = \frac{Q}{22.48} \sqrt{\frac{GT}{(P_1 - P_2) P_2}}$
 P₁ = Inlet Absolute Pressure (gauge pressure + 14.7)
 P₂ = Outlet Absolute Pressure (gauge pressure + 14.7)
 Note: P₂ must be greater than .53 x P₁
 G = Specific Gravity of flowing medium (Air, G = 1)
 T = Absolute Temperature of Air (460 + °F)

Cv = Q x “A” (Table 2)



Notes

Notes

F





Flow Controls & Accessories

Section F (Revised 10/16/08)



Flow Control Valves

"FCM701 & FCM703 Series"	F6
"FC800 & FC806 Series"	F7-F8
PWRA & PWRE	F9-F11
"3251" Series.....	F12
"337" Series.....	F13
"3250" Series.....	F14-F15
"338" Series.....	F16

Check Valves

"339" Series Check Valve.....	F17
"3047" Series Check Valve.....	F18
"VC" Series Check Valve.....	F19

Tank Valves & Air Chucks.....	F20
"EM" Series Exhaust Mufflers.....	F21
Muffler / Flow Controls	F21
Breather Vents.....	F22
"ES" Series Silencer	F22
ASN Air Line Silencer.....	F23
P6M Air Line Silencer	F24
Muffler-Reclassifier ECS	F25
Automatic Drip Leg Drain & Relief Valve.....	F26
Relief Valves - Diaphragm Type.....	F27
Shuttle Valves & Quick Exhaust	F28-F30
Drain Valves.....	F31-F32





"FCM701 & FCM703" Series

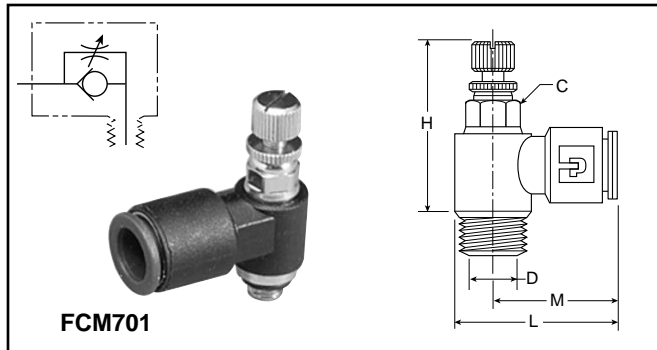

FCM701

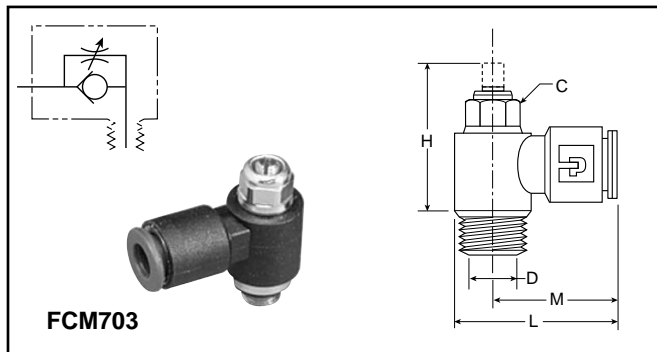

FCM703

General Information

Miniature right angle flow controls provide meter out control of exhaust air from an air cylinder while providing full flow in the reverse direction. The 10-32 male thread can be used to mount directly to cylinder ports. The inlet ports are available in 5-32 or 1/4" instant tube fittings. The adjustment screw is captive and discourages tampering. This compact flow control saves space and reduces the number of fittings involved in making the connection. Plumbing can be oriented 360° about the cylinder port.

Valve Specifications

Maximum Operating Pressure.....145 PSIG (10 bar, 1000 kPa) max.

Temperature Range*.....0°F to 140°F (-18°C to 60°C)

* Ambient temperatures below freezing require moisture-free air. Ambient temperatures below freezing and above 180° require lubricants especially selected for suitability at these temperatures. Pneumatic valves should be used with filtered and lubricated air.

Component Materials

Body.....Polyamide

Mounting Thread..... Brass

Dimensions

Miniature Exhaust Flow Control FCM701

Composite Body

Part No.	Tube Size	Thread Size	C Hex (mm)	H Closed	H Open	L	M	Flow Dia. D	Adjusted Flow (SCFM)	Free Flow (SCFM)
FCM701-5/32-0	5/32	10-32	6	0.925	1.023	0.846	0.669	0.080	5.23	2.90
FCM701-5/32-2	5/32	1/8	7	1.000	1.083	0.935	0.708	0.100	8.41	6.32
FCM701-4-0	1/4	10-32	6	0.925	1.023	0.885	0.708	0.080	9.94	3.86
FCM701-4-2	1/4	1/8	7	1.000	1.083	0.957	0.730	0.100	10.56	5.08
FCM701-4-4	1/4	1/4	8	1.083	1.180	1.013	0.748	0.160	18.79	10.79

Knobless Miniature Exhaust Flow Control FCM703

Composite Body

Part No.	Tube Size	Thread Size	C Hex (mm)	H Closed	H Open	L	M	Flow Dia. D	Adjusted Flow (SCFM)	Free Flow (SCFM)
FCM703-5/32-0	5/32	10-32	6	0.650	0.787	0.846	0.669	0.080	7.43	4.76
FCM703-4-2	1/4	1/8	7	0.708	0.860	0.956	0.730	0.100	12.08	5.86
FCM703-4-4	1/4	1/4	8	0.826	0.964	1.013	0.748	0.160	19.55	10.89

F





“FC800 & FC806” Series

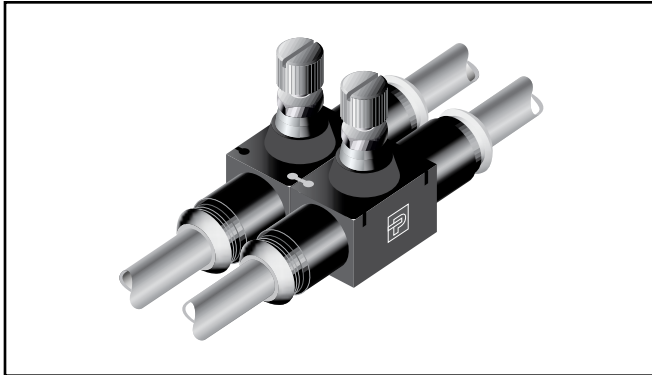

General Information

It is sometimes impossible to mount a flow control directly on the port of the cylinder, either due to lack of space or because of the need for remote adjustment of the flow control. To resolve this problem in-line flow controls are designed to mount on the piping between the directional valve and the cylinder or can be mounted on the control panel next to other control units.

Designed to be Versatile

Parker In-Line Flow Controls are unidirectional flow control valves. Intake air flows freely through the flow control; exhaust air is metered out through a specially designed adjustment screw. An arrow on the body of the valve indicates the direction of controlled flow. Since it is a tube to tube connection, our in-line flow controls may be installed as a meter in or a meter out device. Parker in-line flow controls can be easily added to existing circuitry. Simply splice it into the cylinder port line. In-line flow controls may be used individually or, they may be stacked together using two joining clips, supplied standard with each valve. Panel mounting is accomplished by using the through holes in the molded body.

Adjustment Characteristics

Control is achieved through a finely threaded special adjustment screw. The special shaped adjustment screw produces a more linear flow control than ordinary tapered screws. With the use of a locking nut, the in-line flow control may be secured in its final setting. Settings are maintained even under adverse conditions such as vibration. A captive adjustment screw prevents loss or dangerous blow out.

Full Flow in Both Directions

Intake capacity is always slightly greater than the full open exhaust capacity, enabling maximum variation of speeds between outward and return strokes.

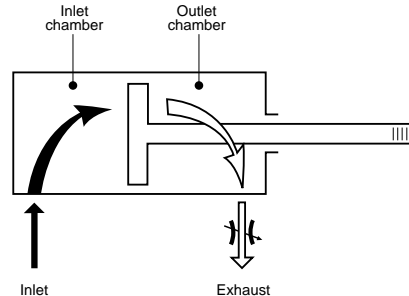
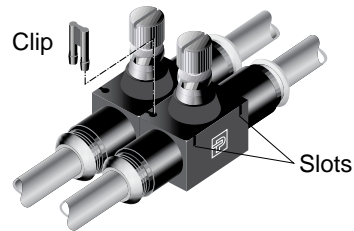
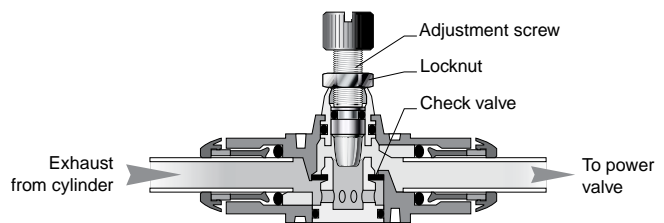

Flow regulation on the exhaust port

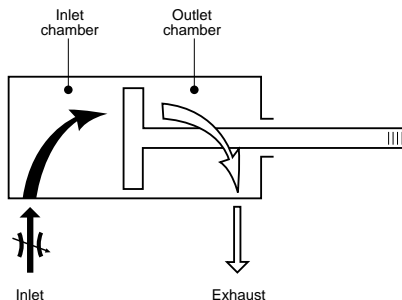

Flow regulation on the inlet port





“FC800 & FC806” Series

Advantages

- Assembly in Banks
- Panel Mounting
- Allows other Function Fittings to be Mounted on a Cylinder
- Space Saving
- Weight Saving
- Flexibility

Valve Specifications

Maximum Working Pressure.....145 PSI
 Operating Temperature 5° to 150°F
 Body MaterialHigh Resistance Polyamide
 Adjustment Screw Material..... Brass

Dimensions

FC800 In-Line Flow Control with Push-in Connection

Part No.	1 ØD	H Min.	H Max.	L	L1	K	N1	N2	T	Orifice	H2 (mm)
FC800-5/32	5/32	1.15	1.31	1.52	.59	.47	.31	.43	.09	.12	5
FC800-4	1/4	1.54	1.74	2.11	.90	.66	.43	.66	.12	.16	8
FC800-6	3/8	2.03	2.38	2.96	1.29	.94	.62	1.01	.16	.31	14
FC800-8	1/2	2.24	2.63	3.35	1.37	1.09	.78	1.07	.16	.39	14

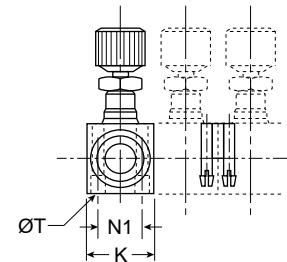
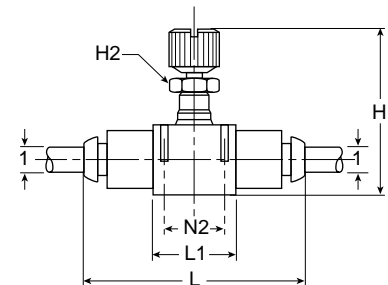

Supplied with 2 clips

FC806 Threaded In-Line Flow Control

Part No.	Thread Size	B Hex (mm)	C Hex (mm)	H Closed	H Open	L	L1	K	N	N1
FC806-2	1/8	13	8	1.56	1.75	2.70	.91	.67	.67	.43
FC806-4	1/4	16	11	1.73	1.97	3.27	1.02	.73	.79	.49
FC806-6	3/8	22	14	2.05	2.40	3.82	1.30	.94	1.02	.63
FC806-8	1/2	24	14	2.26	2.66	4.76	1.38	1.10	1.08	.79

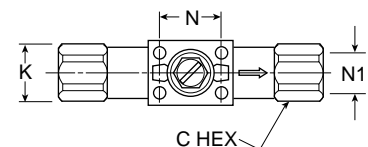
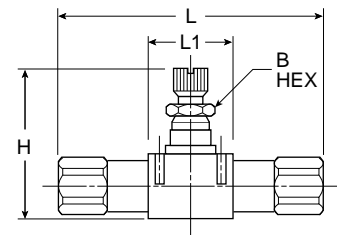

F





PWRA & PWRE Series

General Description

Flow Control – PWRE (Thermoplastic)

These rugged flow controllers enhance the performance of pneumatic cylinders by precise control of piston motion in both directions. They allow full inlet flow to the cylinder while providing fine adjustment of the exhaust flow.

Right angle construction provides for convenient mounting where the cylinder is best controlled . . . at the cylinder port.



PWRE

The PWRE series has a thermoplastic body with brass fittings giving lighter weight and lower profile than its metal counterpart to the left. These flow controls are supplied with instant tube fittings (fractional or metric) and NPT or BSP cylinder port fittings.

Valve Specifications

Maximum Operating Pressure..... 145 PSIG (10 bar)
Operating Temperature 0° to 140°F* (-18°C to 60°F)

* Ambient temperatures below freezing require moisture-free air. Ambient temperatures below freezing and above 180° require lubricants especially selected for suitability at these temperatures. Pneumatic valves should be used with filtered and lubricated air.

PWRA

The PWRA series is made of zinc alloy, built for rugged applications and is available in sizes ranging from 1/8" through 1/2" with cylinder port fittings in either NPT or BSP. Tubing connections are offered either as instant fittings (fractional or metric) or threaded fittings (NPT or BSP). To prevent unwanted drift due to shock or vibration, these devices are fitted with adjustment locking nuts.

Flow

No of Turns	Exhaust (Screw Open)	Inlet (Screw Closed)
12	1.8 SCFM	1.8 SCFM

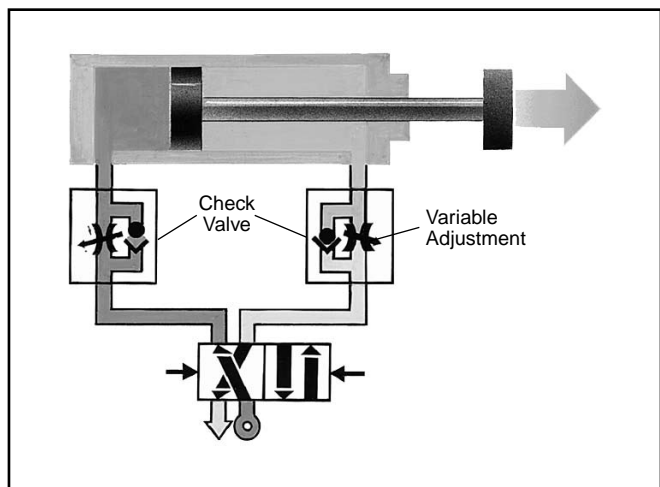
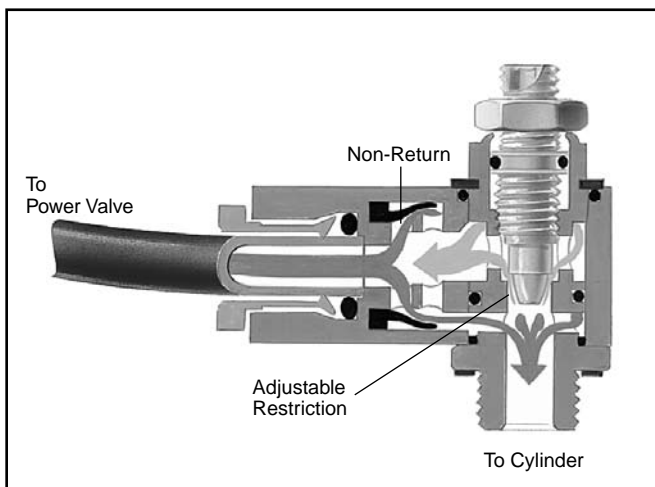



PWRA Series – Metal

For Cylinder Mounting
 (Can also be mounted in Threshold Sensor Banjo)

With Instant Tube Fittings

with Allen key adjustment and locknut



PWRA3469

Symbol	BSP			NPT		
	Cylinder Port Thread	Connection for Tube	Catalog Number	Cylinder Port Thread	Connection for Tube	Catalog Number
	1/8"	6mm	PWRA1468	1/8"	1/4"	PWRA3468
		8mm	PWRA1488			
	1/4"	6mm	PWRA1469	1/4"	1/4"	PWRA3469
		8mm	PWRA1483			
	1/2"	12mm	PWRA1412	1/2"	1/2"	PWRA3412

With Threaded Connection

with Allen key adjustment and locknut



PWRA3833

Symbol	BSP			NPT		
	Cylinder Port Thread	Connection Tapped Thread	Catalog Number	Cylinder Port Thread	Connection Tapped Thread	Catalog Number
	1/8"	1/8"	PWRA1888	1/8"	1/8"	PWRA3888
	1/4"	1/4"	PWRA1899	1/4"	1/4"	PWRA3899
	3/8"	3/8"	PWRA1833	3/8"	3/8"	PWRA3833
	1/2"	1/2"	PWRA1822	1/2"	1/2"	PWRA3822

Dimensions: Inches (mm)

PWRA14**/34**

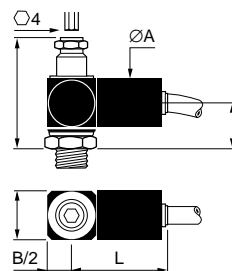

PWRA18**/38**

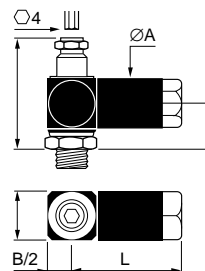

	Adjustment*	Flow**	ØA	B	K	H	L
PWRA1468/3468	10	15.9	0.67" (17)	0.71" (18)	0.67" (17)	1.77" (45)	1.26" (32)
PWRA1488	14	23.0	0.87" (22)	0.83" (21)	0.83" (21)	2.17" (55)	1.54" (39)
PWRA1469/3469	14	26.5	0.87" (22)	0.83" (21)	0.83" (21)	2.17" (55)	1.54" (39)
PWRA1483/3493	14	61.8	1.06" (27)	1.10" (28)	1.02" (26)	2.36" (60)	1.97" (50)
PWRA1412/3412	20	97.1	1.22" (31)	1.30" (33)	1.38" (35)	3.03" (77)	2.60" (66)
PWRA1888/3888	10	15.9	0.67" (17)	0.71" (18)	0.67" (17)	1.77" (45)	1.44" (36.5)
PWRA1899/3899	14	31.8	0.87" (22)	0.83" (21)	0.83" (21)	2.17" (55)	.71" (43.5)
PWRA1833/3833	14	68.9	1.06" (27)	1.10" (28)	1.02" (26)	2.36" (60)	2.19" (55.5)
PWRA1822/3822	20	97.1	1.22" (31)	1.30" (33)	1.38" (35)	3.03" (77)	2.48" (63)

* Number of turns (4mm Allen key)

** SCFM at 90 PSI with screw closed



PWRE Series – Thermoplastic

For Cylinder Mounting
 (Can also be mounted in Threshold Sensor Banjo)

With Instant Tube Fittings

with Allen key adjustment and fine thread friction locking



PWRE14457



PWRE14697

Symbol	BSP			NPT		
	Cylinder Port Thread	Connection for Tube	Catalog Number	Cylinder Port Thread	Connection for Tube	Catalog Number
	M5	4mm	PWRE1445	10-32 UNF	5/32"	PWRE14457
					10-32 UNF	PWRE14557
	1/8"	4mm	PWRE1448	1/8"	5/32"	PWRE14487
		6mm	PWRE1468		1/4"	PWRE14687
	1/4"	6mm	PWRE1469	1/4"	1/4"	PWRE14697
		3/8"	PWRE1483		3/8"	PWRE14937
Reverse Flow	M5	4mm	PWRE1145	10-32UNF	5/32"	PWRE11457

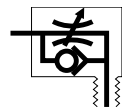

Component Materials

Body..... Polyamide
 Mounting Thread..... Brass

General Information

Miniature right angle flow controls provide meter out control of exhaust air from an air cylinder while providing full flow in the reverse direction. The M5 (10-32) male thread can be used to mount directly to cylinder ports. The inlet ports are available in M5 (10-32) male or 5/32" instant tube fitting. The adjustment screw is captive and discourages tampering. This compact flow control saves space and reduces the number of fittings involved in making the connection. Plumbing can be oriented 360° about the cylinder port.

Flow

No of Turns	Exhaust (Screw Open)	Inlet (Screw Closed)
12	1.8 SCFM	1.8 SCFM

Valve Specifications

Maximum Operating Pressure..... 145 PSIG (10 bar)
 Operating Temperature 0° to 140°F* (-18°C to 60°F)

* Ambient temperatures below freezing require moisture-free air. Ambient temperatures below freezing and above 180° require lubricants especially selected for suitability at these temperatures. Pneumatic valves should be used with filtered and lubricated air.

Dimensions: Inches (mm)

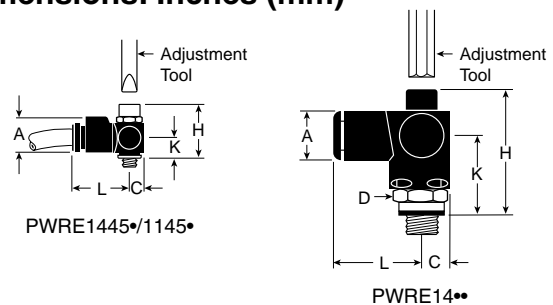

	Adjustment	# Turns	Flow*	ØA	C	D Hex.	K	H	L
PWRE1445/14457 PWRE1145/11457 PWRE14557	3mm screwdriver	12	1.8	0.43" (11)	0.16" (4)	5/16" (8)	0.28" (7.2)	0.67" (17)	0.83" (21)
PWRE1448/14487	3mm Allen key	14	10.2	0.55" (14)	0.31" (8)	9/16" (14)	0.94" (23.8)	1.77" (45)	0.94" (24)
PWRE1468/14687	3mm Allen key	14	23.0	0.55" (14)	0.31" (8)	9/16" (14)	0.94" (23.8)	1.77" (45)	0.94" (24)
PWRE1469/14697	4mm Allen key	18	23.0	0.63" (16)	0.41" (10.5)	11/16" (17)	1.04" (26.5)	1.94" (49.3)	1.06" (27)
PWRE1483/14937	4mm Allen key	18	47.7	0.79" (20)	0.45" (11.5)	7/8" (22)	1.17" (29.8)	2.24" (56.8)	1.30" (33)

* SCFM at 90 PSI with screw closed



“3251” Series

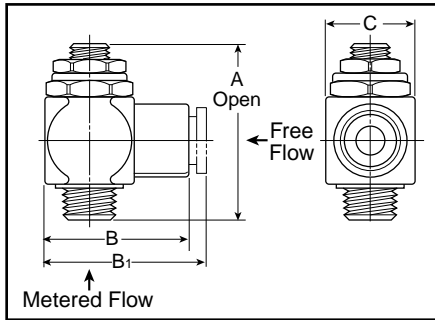
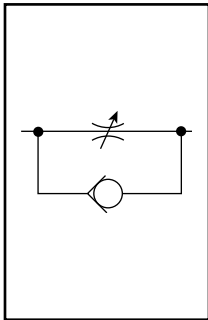
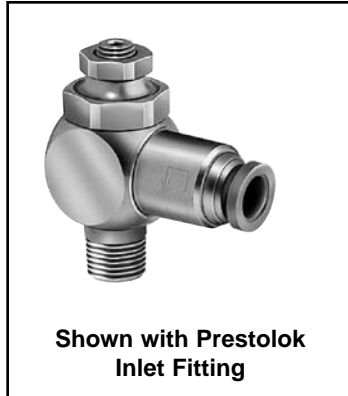

Application

The Right Angle Flow Control is an ideal solution to cylinder speed control where space is at a premium. Costly fittings, connections and piping expenses can be eliminated because the valve can rotate 360°, the piping alignment can be in any direction. The 1/8" model can be rotated after final assembly.

Operation

Install by threading male end directly into cylinder port. The free-flow and metered-flow direction is automatically predetermined. Free-flow direction is into cylinder and metered-flow is out of the cylinder. Flow is adjusted with an Allen wrench and locked with nut.

Right Angle Flow Control also available with Prestolok fittings on inlet port to accommodate 5/32 - 3/8 tube sizes. This allows for quick connection and eliminates need for separate tube fitting.

Valve Specifications

- Body**..... Brass
- Plunger** Brass and Acetal
- Seals** Buna N
- Temperature Range**.....0°F to 140°F (-18°C to 60°C)
- Pressure Rating**..... 125 PSIG (863 kPa) max.

Model Selection Information and Dimensions

Model Number	Thread (NPT) Male	Thread (NPT) Female	A		B		C		Weight		Cv	
			Inches	mm	Inches	mm	Inches	mm	oz.	kg.	Adjusted Flow	Free Flow
03251 0125	1/8	1/8	1.74	44	1.18	30	0.67	17	2.0	0.9	0.26	0.20
03251 0250	1/4	1/4	1.99	51	1.40	36	0.91	23	4.5	2.0	0.75	0.68
03251 0375	3/8	3/8	2.28	58	1.71	43	1.06	27	7.0	3.2	0.84	0.72
03251 0500	1/2	1/2	2.69	68	1.98	53	1.26	32	11.0	5.0	1.64	1.41
With Prestolok Fittings	Thread (NPT)	Tube Size	A		B ₁		C		Weight		Cv	
03251 1215	1/8	5/32	1.74	44	1.18	30	0.67	17	2.0	0.9	0.19	0.16
03251 1225	1/8	1/4	1.74	44	1.18	30	0.67	17	2.0	0.9	0.28	0.22
03251 2525	1/4	1/4	1.99	51	1.40	36	0.91	23	4.5	2.0	0.51	0.44
03251 2538	1/4	3/8	1.99	51	1.40	36	0.91	23	4.5	2.0	0.62	0.53
03251 3838	3/8	3/8	2.28	58	1.71	43	1.06	27	7.0	3.2	0.78	0.65

CAUTION: If it is possible that the ambient temperature may fall below freezing, the medium must be moisture-free to prevent internal damage or unpredictable behavior.



"337" Series

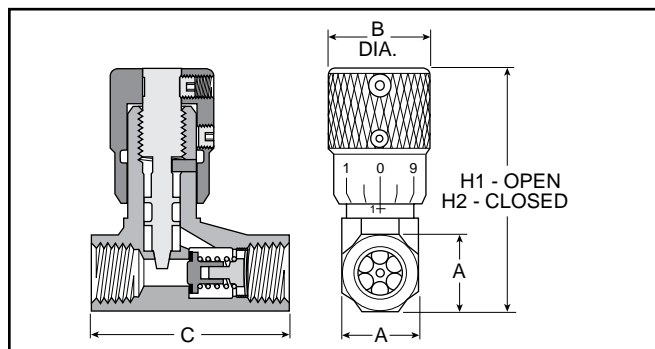
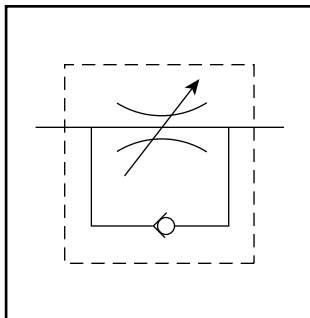

General Information

The "337" Series Flow Control Valves meter flow of air in one direction and allow free flow in the reverse direction. The "337" Series valves are manufactured with a fine tapered needle providing precise flow control, even at low flow rates. The perimeter of the adjustment knob features numerical micrometer position markings providing a visual indication of the setting. Once the desired flow is selected, a set screw can be tightened to maintain the setting. These valves are available with NPTF ports in 1/8", 1/4", 3/8", 1/2", and 3/4" sizes. This series is recommended for pneumatic service.

Valve Specifications

Maximum Operating Pressure250 PSI
 Cracking pressure for return check poppet..... 1 to 2 PSIG
Operating TemperatureStandard: 0° to 180°F*
 Extended Temperature 0° to 300°F* (consult factory)

* Ambient temperatures below freezing require moisture-free air. Ambient temperatures below freezing and above 180° require lubricants especially selected for suitability at these temperatures. Pneumatic valves should be used with filtered and lubricated air.

Component Materials

Body Material Brass
Needle..... Stainless Steel
Check Seal Urethane
Needle Seals Buna N
 (Fluorocarbon optional – consult factory)
Knob Aluminum
Spring Stainless Steel
Retainer Zinc- Plated Steel
Set Screw Steel

Model Selection and Dimensions

Port Size	Model	Flow (SCFM) [†]		Dimensions					Service Kit
		Adj.	Free Flow	A	B	C	H1	H2	
1/8"	00337 1000	15	32	9/16"	0.75	1.47	2.03	1.81	00337 8000
1/4"	00337 1001	28	75	11/16"	0.75	1.47	2.28	2.03	00337 8001
3/8"	00337 1002	59	139	7/8"	0.88	2.31	2.84	2.53	00337 8002
1/2"	00337 1003	126	183	1-3/16"	1.06	3.25	3.62	3.22	00337 8003
3/4"	00337 1004	140	327	1-3/8"	1.06	3.25	3.72	3.31	00337 8004

† At 100 PSIG inlet pressure with full pressure drop.

Mounting Bracket Model Selection and Dimensions

Port Size	Mounting Bracket Model No.	Dimensions						
		A	B	C	D	E	F	G
1/8"	00337 8100	0.66	0.66	0.505	0.75	1.38	1.88	0.22
1/4"	00337 8101	0.75	0.89	0.505	0.75	1.50	2.00	0.22
3/8"	00337 8102	0.94	1.12	0.630	1.25	1.75	2.31	0.27
1/2"	00337 8103	1.25	1.62	0.755	1.75	2.06	2.62	0.27
3/4"	00337 8104	1.44	1.72	0.755	1.75	2.25	2.81	0.27

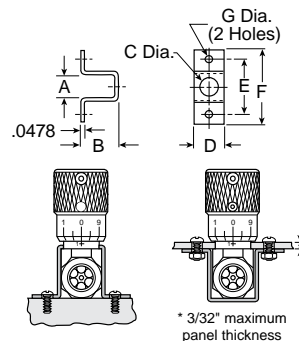

"3250" Series

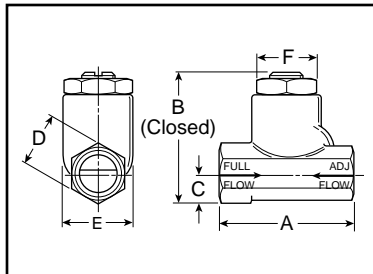
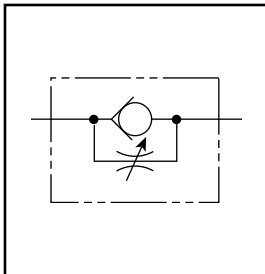
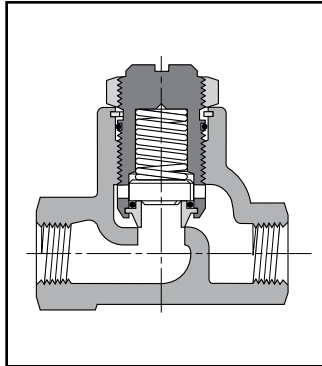

Application

The "3250" Series Flow Control Valves are specifically designed to accurately meter the flow of air in one direction and allow free flow in the opposite direction. The "3250" Series Flow Control Valves are also suitable for low pressure hydraulic service.

Operation

When air is moving in the free flow direction through the valve, it forces the poppet off its seat and unrestricted air flow is permitted.

When air is moving in the metered direction through the valve, air pressure and the force of the poppet spring causes the poppet to close. Flow must then be through the orifice that is controlled by the metering screw. Opening this screw allows more flow; closing it, less flow.

Technical Specifications

- Body..... Brass
 - Port Size..... 1/8", 1/4", 3/8", 1/2", 3/4"
 - Internal Components.....Brass, Stainless Steel
 - Seals..... Buna N
 - Operating TemperatureStandard: 0°F to 180°F
 Extended Options: 0°F to 300°F
 - Operating Pressures:
 - Air.....250 PSIG
 - Hydraulic.....250 PSIG
- Valve will operate mounted in any position.
 Lock nut on metering screw prevents change in setting during operation.

Flow Rating (SCFM)

Flow Path	Valve Port Size				
	1/8"	1/4"	3/8"	1/2"	3/4"
Maximum Flow in Metered Direction	70	130	220	295	420
Maximum Flow in Free Flow Direction	60	120	205	346	615

Model Selection Information and Dimensions

Model Number	03250 0119		03250 0219		03250 0319		03250 0419		03250 0519	
Port Size NPTF	1/8"		1/4"		3/8"		1/2"		3/4"	
	Inches	mm	Inches	mm	Inches	mm	Inches	mm	Inches	mm
A	1.75	45	2.33	59	2.66	68	3.11	79	3.56	90
B	1.56	40	1.97	50	2.44	62	3.06	78	3.69	94
C	0.37	9	0.44	11	0.56	14	0.75	19	0.88	22
D	0.62	16	0.75	19	1.00	25	1.25	32	1.50	38
E	0.81	21	1.09	28	1.38	35	1.63	41	2.00	51
F	0.68	17	0.94	24	1.19	30	1.38	35	1.75	44

F



"3250" Series

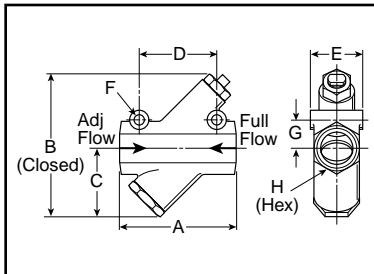
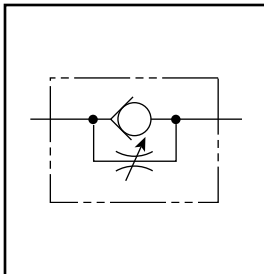
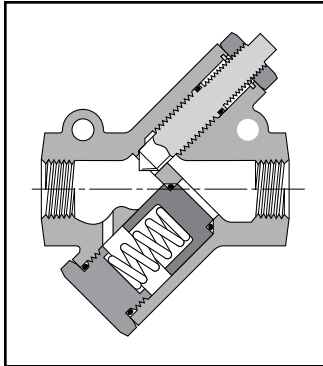
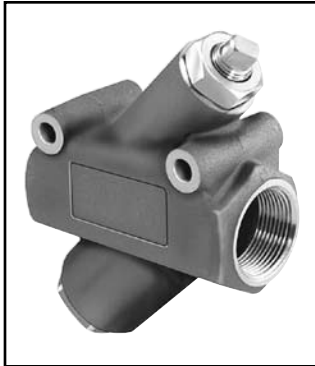

Application

These extra large flow control valves have been developed to provide effective flow settings for large diameter cylinders and for other similar air applications. Each valve has a fine screw adjustment allowing precise settings which are secured by a sturdy lock nut.

Operation

Large internal port passages coupled with unique soft seal poppet and inline design provide maximum full flow capacity and minimum pressure drop in the free flow direction. Their cone shaped brass metering valve will provide consistent cylinder speed by regulating cylinder exhaust.

Technical Specifications

- Body..... Cast Aluminum
- Port Size 1", 1-1/4", 1-1/2"
- Internal Components..... Brass, Aluminum
- Seals Buna N, Urethane
- Spring Stainless Steel
- Operating Temperature:**
 Standard..... -40°F to 180°F
 Extended Options..... -40°F to 350°F
- Operating Pressures:**
 Maximum Air..... 250 PSIG

Flow Capacity In Full Flow Direction

Port Size (NPTF)	Max. Flow (Needle Open)		Model Number
	SCFM**	C _v	
1	1000	12.3	03250 1000
1-1/4	1200	13.8	03250 1250
1-1/2	1800	17.5	03250 1500

** At 100 PSIG inlet pressure with full pressure drop.

Model Selection Information and Dimensions

Model Number	03250 1000		03250 1250		03250 1500	
Port Size NPTF	1"		1-1/4"		1-1/2"	
	Inches	mm	Inches	mm	Inches	mm
A	5.00	127	5.00	127	5.88	149
B	6.50	165	6.50	165	8.00	203
C	3.00	76	3.00	76	3.75	95
D	3.25	83	3.25	83	3.50	89
E	2.25	57	2.25	57	2.50	64
F	.39	10	.39	10	.39	10
G	1.31	33	1.31	33	1.50	38
H	2.13	54	2.13	54	2.38	60



"338" Series

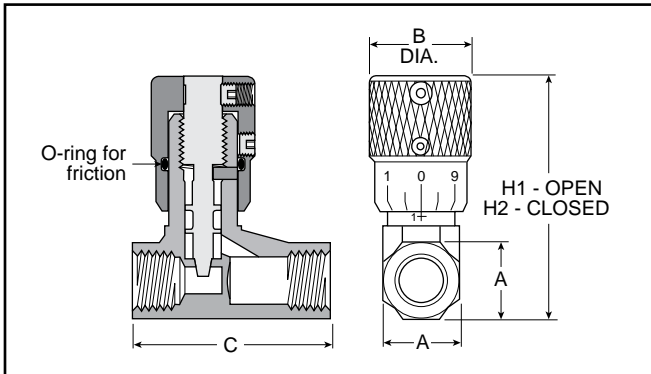
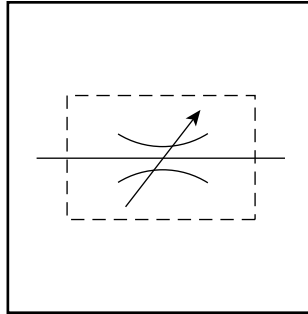

General Information

"338" Series needle valves bi-directionally meter the flow of air through the valve.

This series features a fine tapered needle providing precise flow of air in both directions. Numerical micrometer position markings are stamped on the perimeter of the adjustment knob which provide a visual indication of the setting. Once the desired flow is selected, a set screw can be tightened to maintain the setting.

These valves are available with NPTF ports in 1/8", 1/4", 3/8" 1/2" and 3/4" sizes. This series is recommended for pneumatic service

Valve Specifications

Maximum Operating Pressure 250 PSIG (Air)

Operating Temperature Standard: 0° to 180°F*
Extended Temperature 0°F to 300°F* (Consult factory)

* Ambient temperatures below freezing require moisture-free air. Ambient temperatures below freezing and above 180° require lubricants especially selected for suitability at these temperatures. Pneumatic valves should be used with filtered and lubricated air.

Component Materials

Body Material Brass
Internal Components Stainless Steel / Brass
Seals Nitrile (Fluorocarbon optional – consult factory)

Model Selection and Dimensions

Model Number	Port Size	Dimensions					Kit
		A	B	C	H1	H2	
00338 1100	1/8"	9/16"	0.75	1.47	2.03	1.81	00337 8000
00338 1101	1/4"	11/16"	0.75	1.47	2.28	2.03	00337 8001
00338 1102	3/8"	7/8"	0.88	2.31	2.84	2.53	00337 8002
00338 1103	1/2"	1-3/16"	1.06	3.25	3.62	3.22	00337 8003
00338 1104	3/4"	1-3/8"	1.06	3.25	3.72	3.31	00337 8004

Performance Data – Flow

Model Number	Port Size	Flow (SCFM†)
00338 1100	1/8"	15
00338 1101	1/4"	28
00338 1102	3/8"	59
00338 1103	1/2"	126
00338 1104	3/4"	140

† At 100 PSIG inlet pressure with full pressure drop.

F



"339" Series

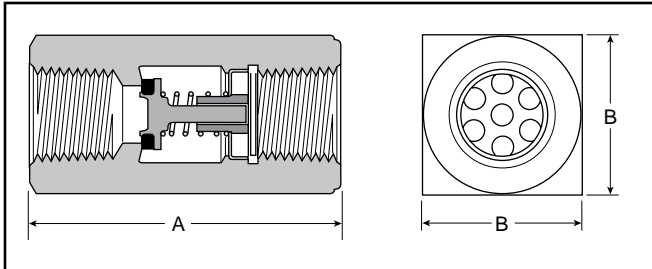
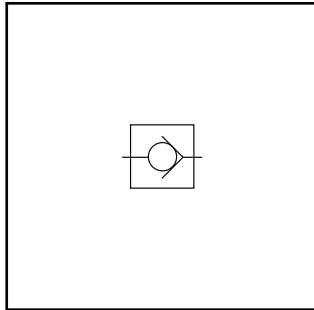

General Information

"339" Series check valves allow free flow in one direction and provide positive checked (zero flow) in the reverse direction. These valves are available with NPTF ports in 1/8", 1/4", 3/8", 1/2" & 3/4" sizes. This series is recommended for pneumatic service.

Valve Specifications

Maximum Operating Pressure..... 250 PSIG
 Cracking Pressure 1 to 2 PSIG

Operating Temperature –

Standard..... 0° to 180° F*
 Extended Temperature Option..... 0°F to 300°F*

* Ambient temperatures below freezing require moisture-free air. Ambient temperatures below freezing and above 180° require lubricants especially selected for suitability at these temperatures. Pneumatic valves should be used with filtered and lubricated air.

Component Materials

Body..... Brass
Internal ComponentsBrass / Stainless Steel / Zinc-Plated Steel
SealsUrethane (standard), Fluorocarbon (optional – consult factory)

Model Selection and Dimensions

Model Number	Port Size	Flow† (SCFM)	Dimensions		Service Kit
			A	B	
00339 3000	1/8"	35	1.22	0.56	00337 8000
00339 3001	1/4"	75	1.34	0.69	00337 8001
00339 3002	3/8"	143	2.00	0.88	00337 8002
00339 3003	1/2"	162	2.56	1.19	00337 8003
00339 3004	3/4"	323	2.66	1.38	00337 8004



"3047" Series

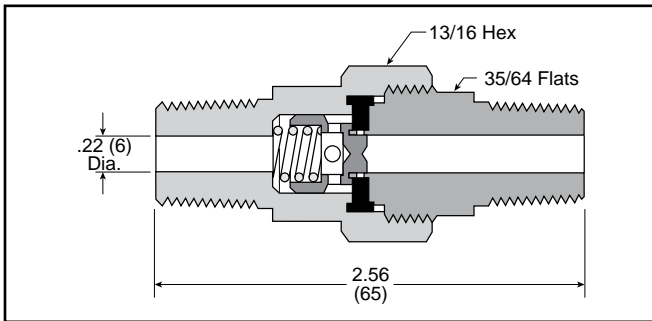
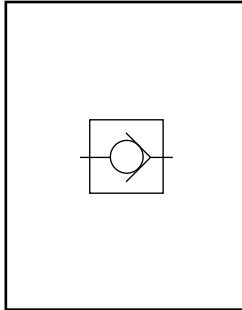

General Information

"3047" Series check valves allow free flow in one direction and provide positive checked (zero flow) in the reverse direction. This valve is available with a male 1/4" NPTF connection and is recommended for pneumatic service.

Valve Specifications

Maximum Operating Pressure..... 250 PSIG

Cracking Pressure..... 1 to 2 PSIG

Operating Temperature Standard: 0° to 180° F*

* Ambient temperatures below freezing require moisture-free air. Ambient temperatures below freezing and above 180° require lubricants especially selected for suitability at these temperatures. Pneumatic valves should be used with filtered and lubricated air.

Component Materials

Body Material Brass

Internal Components..... Brass / Stainless Steel

Seals Nitrile

Model Selection

Model Number	Pipe Thread	Flow† (SCFM)
03047 0099	1/4"	30

† At 100 PSIG inlet pressure with full pressure drop.

F

“VC” Series

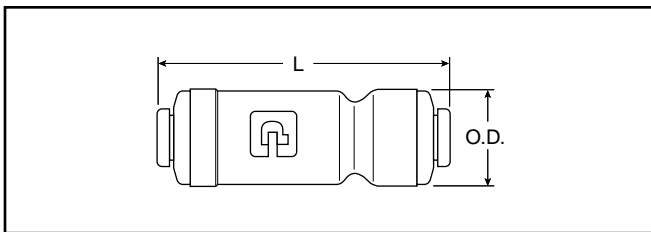

General Information

Push-to-Connect check valves that ensures protection against reversal of flow. The valves have an arrow molded into the body to indicate the direction of flow. Valves are designed for connection with either thermoplastic or soft metal tubing and are intended for use with liquids only.

Valve Specifications

Working Pressure Up to 150 PSI
 depending on tubing being used
Temperature Range +34°F (1° C) to +150°F (65°C)
Cracking Pressure 1/3 PSI

Assembly Instructions

1. Cut tubing squarely, be certain the tubing is clean and free of debris.
2. Insert tubing into check valve until it bottoms. A slight twisting motion will ease the insertion. Pull on tubing to verify it is properly retained in the fitting.
3. To disassemble, simply push in the release button against the body and remove the tubing

Component Materials

Body Acetal
O-ring EPDM
Metal Grip Edge 300 Stainless

Model Selection and Dimensions

Part No.	Tube Size	L	O.D.
A4VC4-MG	1/4	2.00	0.66
A5VC5-MG	5/16	2.10	0.70
A6VC6-MG	3/8	2.15	0.80



Tank Valves **Air Chucks**

For tanks, steel barrels, compressors and other pneumatic containers where a dependable automatic air valve is needed. Equipped with standard valve core and sealing cap. Maximum operating pressure is 185 PSIG. Temperature range is -40°F to 220°F.

Model No. 09166 0060

Has a 1/8" pipe thread at bottom for minimum protrusion. N/P finish, dome shaped cap. Packed 25 to a box.

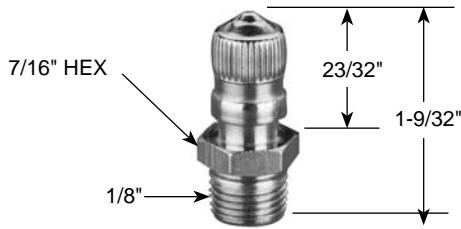

For regular airlines.

Model No. 05499 0000

Ball-foot air chuck, 1/4" female port. Packed 10 to a box.



Model No. 00645 0060

A 1/8" pipe thread at bottom permits maximum protrusion. N/P finish, screwdriver type cap. Packed 25 to a box.

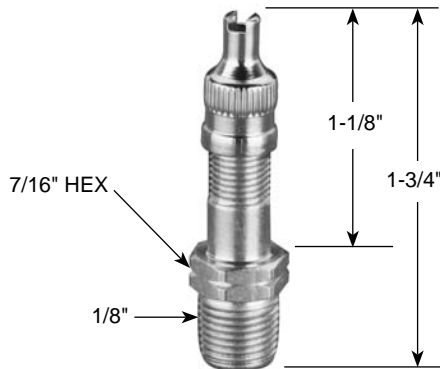

Model No. 06739 0000

Ball-foot air chuck with clip. Fits standard valve mouth. Saves holding on by hand. Has 1/4" port for connecting to hose. Packed 10 to a box.



Model No. 01468 0006

Has a 1/8" pipe thread part way up the stem which allows for minimum protrusion. N/P finish, has screwdriver type cap. Packed 25 to a box.

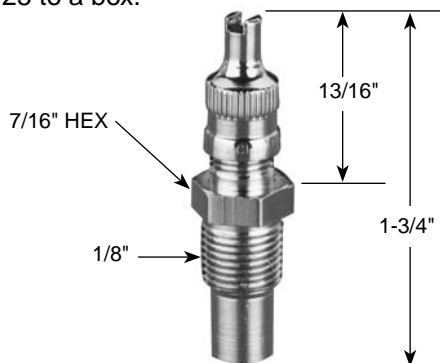

F

“EM” Series – Sintered Bronze Muffler / Filters

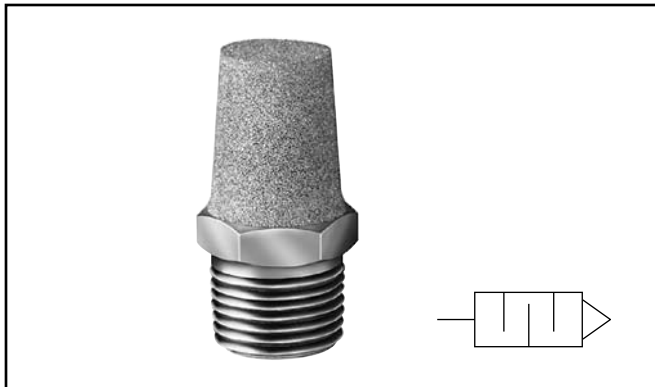

General Description

Muffler / filters effectively reduce air exhaust noises to an industry accepted level with minimum flow restriction. They protect valves, impact wrenches, screw drivers and other air tools by preventing dirt and other foreign matter from entering the system. Non-corrosive. Can be cleaned with many common solvents.

Specifications

Maximum Operating Pressure..... 250 PSIG (Air)

Operating Temperature 0° to 300°F*

* Ambient temperatures below freezing require moisture-free air. Ambient temperatures below freezing and above 180° require lubricants especially selected for suitability at these temperatures. Pneumatic valves should be used with filtered and lubricated air.

Model Number	Pipe Thread	Overall Length	Hex Size
EM12	1/8"	1.00	7/16"
EM25	1/4"	1.32	9/16"
EM37	3/8"	1.54	11/16"
EM50	1/2"	1.85	7/8"
EM75	3/4"	2.29	1-1/16"
EM100	1"	2.91	1-5/16"
EM125	1-1/4"	3.25	1-11/16"
EM150	1-1/2"	3.69	2"

Muffler / Flow Controls



General Description

Muffler / flow controls provide an acceptable exhaust noise level and effectively meter exhaust. Installed in valve exhaust ports, they control cylinder piston speeds throughout a wide range. The adjusting screw cannot be accidentally blown out, can be locked to maintain setting. Brass and bronze construction. Clean with commonly used solvents.

Specifications

Maximum Operating Pressure..... 250 PSIG (Air)

Operating Temperature 0° to 300°F*

* Ambient temperatures below freezing require moisture-free air. Ambient temperatures below freezing and above 180° require lubricants especially selected for suitability at these temperatures. Pneumatic valves should be used with filtered and lubricated air.

Model Number	Pipe Thread	Overall Length	Hex Size
04502 0002	1/8"	1.15	9/16"
04504 0004	1/4"	1.42	1/2"
04506 0060	3/8"	1.49	11/16"
04508 0080	1/2"	1.77	7/8"
04512 0012	3/4"	1.98	1-1/16"
04516 0016	1"	2.15	1-5/16"



Breather Vents & "ES" Series



NOTE: Breather vents should not be used as exhaust mufflers.

General Description

These low silhouette versions of the muffler / filter are useful where space is a problem and / or to prevent contamination. Use for vacuum relief or pressure equalization in gear boxes, oil tanks, reservoirs, etc. Non-corrosive.

Specifications

Maximum Operating Pressure..... 150 PSIG (Air)

Operating Temperature 0° to 300°F*

* Ambient temperatures below freezing require moisture-free air. Ambient temperatures below freezing and above 180° require lubricants especially selected for suitability at these temperatures. Pneumatic valves should be used with filtered and lubricated air.

Model Number	Pipe Thread	Overall Length	Hex Size
04702 0002	1/8"	0.44	7/16"
04704 0004	1/4"	0.63	9/16"
04706 0006	3/8"	0.75	11/16"
04708 0008	1/2"	0.88	7/8"
04712 0012	3/4"	1.00	1-1/6"
04716 0016	1"	1.31	1-5/16"
04720 0020	1-1/4"	1.41	1-11/16"
04724 0024	1-1/2"	1.50	2"

"ES" Series – Silencer

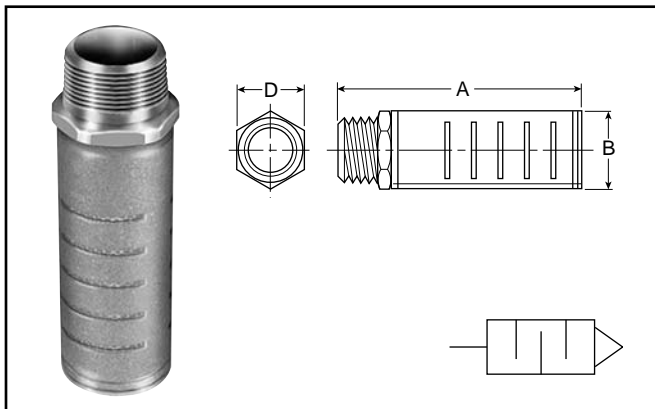

General Description

These low silhouette versions of the muffler / filter are useful where space is a problem and / or to prevent contamination. Use for vacuum relief or pressure equalization in gear boxes, oil tanks, reservoirs, etc. Non-corrosive.

The silencer is designed to give superior performance in noise control with a minimum effect on air efficiency. "Trimline" design allows location in the tightest places without extra plumbing and fittings. Fits directly into the exhaust port of more than 90% of present commercial valves. Slotted body permits rapid discharge of air without undesirable back pressure. Unique nylon screen element resists dirt buildup or clogging.

Specifications

Maximum Operating Pressure..... 250 PSIG (Air)

Operating Temperature 0° to 300°F*

* Ambient temperatures below freezing require moisture-free air. Ambient temperatures below freezing and above 180° require lubricants especially selected for suitability at these temperatures. Pneumatic valves should be used with filtered and lubricated air.

Model Numbers		Pipe Thread	Flow SCFM @ 100 PSIG Inlet	Dimensions		
NPTF	BSPT (R)			A	B	D
ES12MC	ESB12MC	1/8"	115	1.85	0.81	0.63
ES25MC	ESB25MC	1/4"	129	1.85	0.81	0.63
ES37MC	ESB37MC	3/8"	219	3.31	1.26	1.00
ES50MC	ESB50MC	1/2"	549	3.31	1.26	1.00
ES75MC	ESB75MC	3/4"	893	4.56	2.01	1.62
ES100MC	ESB100MC	1"	1,013	4.56	2.01	1.62
ES125MC	ESB125MC	1-1/4"	1,486	5.69	2.88	—
ES150MC	ESB150MC	1-1/2"	1,580	5.69	2.88	—

F



ASN Series

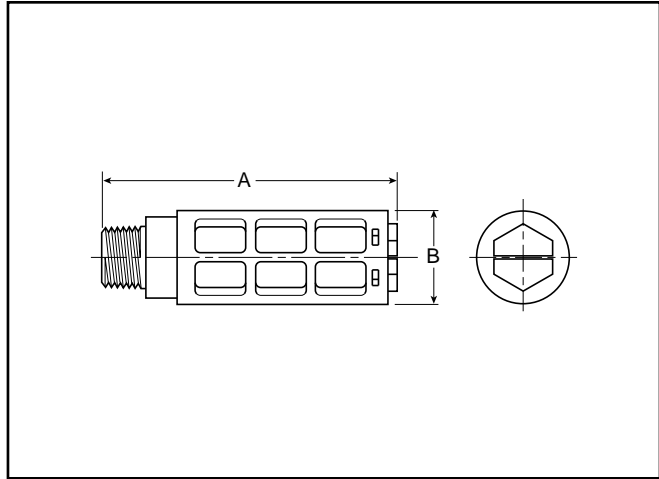

Features

- Compact
- Lightweight
- Easy to Install
- Excellent Noise Reduction
- Protects Components from Contamination
- NPT and BSPT Threads Available

Application

The plastic silencer is designed to give excellent noise reduction with a minimum effect on air efficiency. The "Trimline" design allows for locating the silencer in the tightest places without extra plumbing or fittings. Fits directly into the exhaust port of most commercial valves. Open surface area of element allows for rapid discharge of air without undesirable back pressure.

Part Number		Thread Size	A (mm)	B (mm)	Maximum Flow (SCFM) 100 PSIG Inlet	Sound Pressure Level (dBA)	
NPT	BSPT					20 PSIG Inlet	100 PSIG Inlet
AS-5		M5	0.43 (11)	0.32 (8)	15	69	79
ASN-6	AS-6	1/8"	1.57 (40)	0.63 (16)	51	69	81
ASN-8	AS-8	1/4"	2.56 (65)	0.83 (21)	124	67	84
ASN-10	AS-10	3/8"	3.35 (85)	0.98 (25)	247	83	98
ASN-15	AS-15	1/2"	3.74 (95)	1.18 (30)	370	69	96

Specifications

Pressure Rating0 to 150 PSIG
 (0 to 10 bar, 0 to 1034 kPa)
 Temperature Rating14°F to 140°F (-10°C to 60°C)
 Body Acetal (Plastic)
 Element Polyethylene





P6M Series

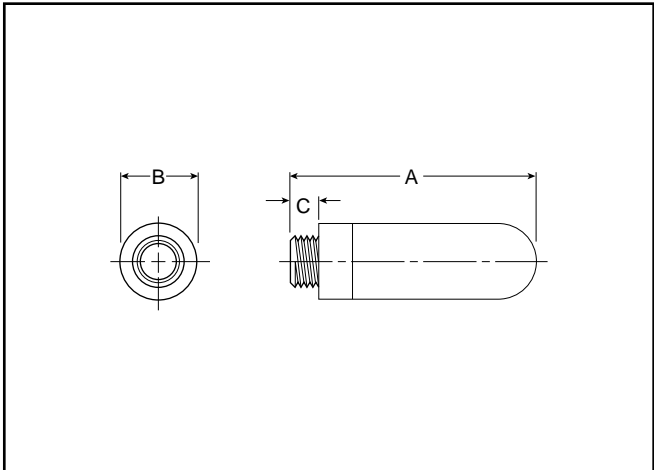
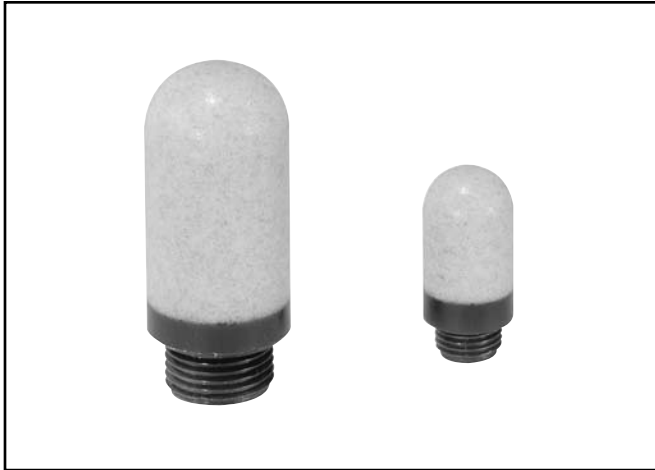

Features

- All Plastic Ultra Light Weight Versions
- High Noise Level Reduction
- Low Back Pressure Generation

Application

The plastic silencer is designed to give excellent noise reduction with a minimum effect on air efficiency. The “Trimline” design allows for locating the silencer in the tightest places without extra plumbing or fittings. Fits directly into the exhaust port of most commercial valves. Open surface area of element allows for rapid discharge of air without undesirable back pressure.

Part Number	Port Thread	A	Diameter B	C	Weight (grams)
P6M-PAC5	M5	0.91 (23)	0.26 (6,5)	0.16 (4)	0.01
P6M-PAB1	G1/8	1.14 (29)	0.55 (14)	0.24 (6)	0.02
P6M-PAB2	G1/4	1.34 (34)	0.67 (17)	0.24 (6)	0.04
P6M-PAB3	G3/8	2.36 (60)	0.98 (25)	0.35 (9)	0.06
P6M-PAB4	G1/2	2.52 (64)	0.98 (25)	0.43 (11)	0.10
P6M-PAB6	G3/4	5.51 (140)	1.50 (38)	0.55 (14)	0.50
P6M-PAB8	G1	6.30 (160)	1.89 (48)	0.79 (20)	0.62



Specifications

Pressure Rating0 to 246 PSIG
(0 to 17 bar, 0 to 1700 kPa)

Temperature Rating

Plastic14°F to 176 °F (-10°C to 80°C)
Metal14°F to 165 °F (-10°C to 74°C)

Efficiency..... 92%





ECS Series

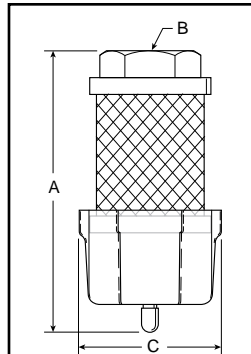

Dimensions:

Model	A	B	C
ECS3	5.30 (135 mm)	1/2" NPT	2.57 (65 mm)
ECS5	7.30 (185 mm)	1" NPT	2.57 (65 mm)

Operation

Compressor oils and lubricating oils are exhausted from valves, cylinders and air motors into the ECS. Oil aerosols are “coalesced” into larger droplets and gravity pulls them into the attached drain sump. The sump can then be drained manually or by using a 1/4" ID plastic tube drain. The air flowing into the ECS is also muffled or silenced as it enters the inside of the ECS and passes through the filter media into the atmosphere.

Proven Technology

The ECS units are constructed from the same materials that go into our oil removal coalescing filter elements. The seamless design insures media uniformity and strength. This proven technology provides high coalescing efficiency with low pressure drop. The filter media is supported by cylindrical perforated steel retainers both inside and out. These retainers, fully plated for excellent corrosion resistance, give the ECS units high rupture strength in either flow direction. These filters can also be used as high efficiency inlet or bypass filters for vacuum pumps, or breather elements to protect the air above critical process liquids.

ECS3 / ECS5

The ECS solves two problems inherent in compressed air exhaust from valves, cylinders and air motors - oil mist removal and noise abatement. The ECS will improve your industrial plant environment, thereby improving worker productivity.

Performance Characteristics

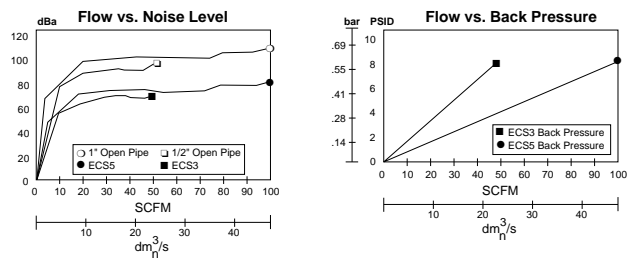

Features

The ECS (Muffler-Reclassifier) eliminates unwanted oil mist and reduces exhaust noise from pneumatic valves, cylinders and air motors.

- 99.97% Oil Removal Efficiencies
- 25 dBA Noise Attenuation
- 1/2" NPT and 1" NPT
- Disposable Units
- Continuous or Plugged Drain Option
- Metal Retained Construction
- Fast Exhaust Time

Improve Overall Plant Environment

Exhaust oil mist and noise pollution have a direct impact on worker productivity. Oil aerosol mist from lubricators and compressors is pervasive and enters the industrial plant environment through the exhaust ports of valves, cylinders and air motors. This rapidly expanding exhaust also produces sudden and excessive noise. The ECS (Muffler-Reclassifier) is 99.97% efficient at removing the oil aerosols. The ECS also acts as a silencer to lower the dBA levels below O.S.H.A. requirements. The result is a cleaner, quieter environment which equates to greater work productivity and safety.

Specifications

Maximum Operating Temperature 125°F (52°C)
Maximum Line Pressure 100 PSIG (6.8 bar)

Ordering Information

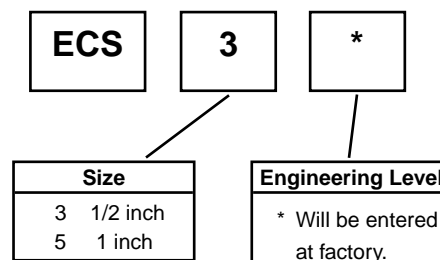

Automatic Drip Leg Drain, Relief Valve

Automatic Drip Leg Drain Relief Valve

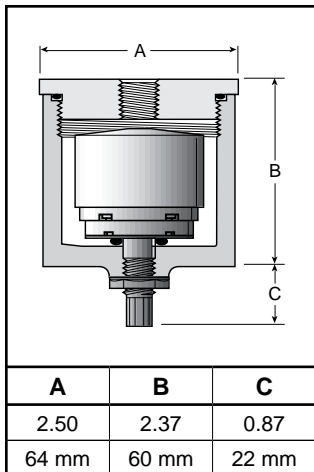

Features

- Auto Drain Ported 1/8" to Pipe Away Liquid
- Drain has Manual Override
- Easily Serviced Without Tool
- 20-250 PSIG Range
- Compact Size

Specifications

Housing & Cap.....Aluminum
 Port Threads..... 1/4" - 1/2" Top
 1/8" Drain
Pressure and Temperature Ratings:
 Metal Bowl..... 20 to 250 PSIG (0 to 17.2 bar)
 32°C to 175°F (0°C to 80°C)
 Seals..... Buna N

Ordering Information

Consists of Drip Leg Drain Housing WITH Auto Drain.

Model No.	Size
06D1NA	1/4"
06D3NA	1/2"

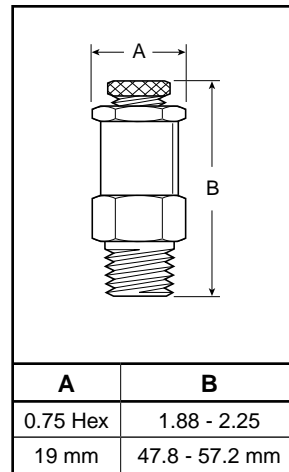
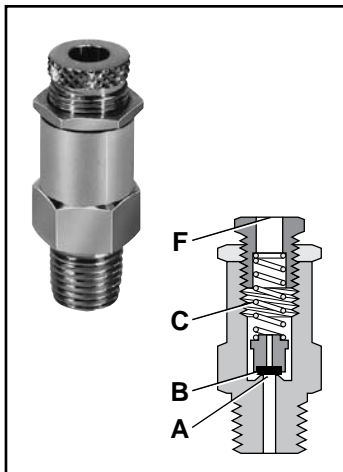

Features

- Large Relief Capacity in a Compact Size
- Lightweight Aluminum Construction with Resilient Seat

Application

The RV01A1N Pop Off Relief Valve is designed to protect against excessive pressure buildup in a pneumatic circuit or system.

Operation*

With the relief valve mounted in a reservoir or system, the force of system pressure at (A) is offset by the force of spring (C) acting on poppet seat (B). At pressures lower than the setting, the poppet seat (B) is held against the body at (A) effecting a seal. As pressure approaches set point, the poppet begins to vent until set point is reached, at which time the poppet seat (B) lifts off the body at (A) allowing the excess pressure to vent to atmosphere at (F). When the excess pressure has been vented, the spring (C) acts on the poppet seat (B) forcing it to seat on the body at (A), sealing off the flow of air.

Specification

Body & Adjusting Screw.....Aluminum
 Locking Nut..... Steel
 Seat Nitrile
 Spring..... Steel
 Poppet..... Plastic
 Operating Temperature..... 32°F to 200°F (0°C to 93°C)
 Port Threads..... 1/4 Inch Male
 Relief Range..... 10 to 200 PSIG (.7 to 14 bar)
 with standard spring.

* Ref: 1RV100B Installation & Service Instructions

Ordering Information

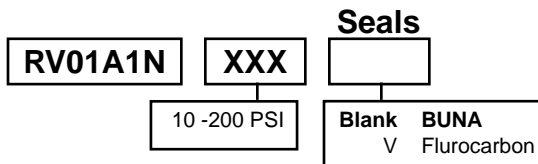

130 Relief Valve

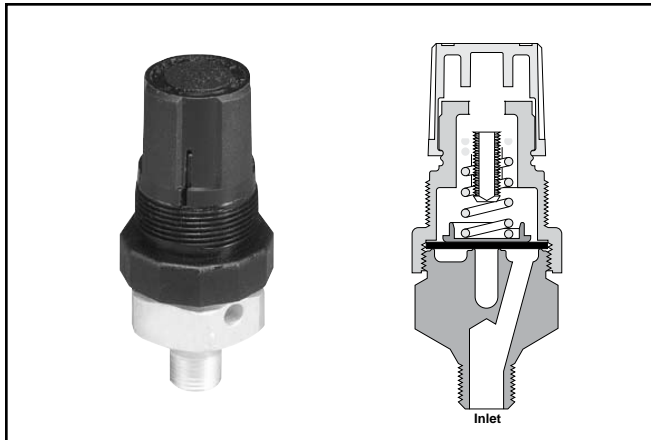

134 Relief Valve

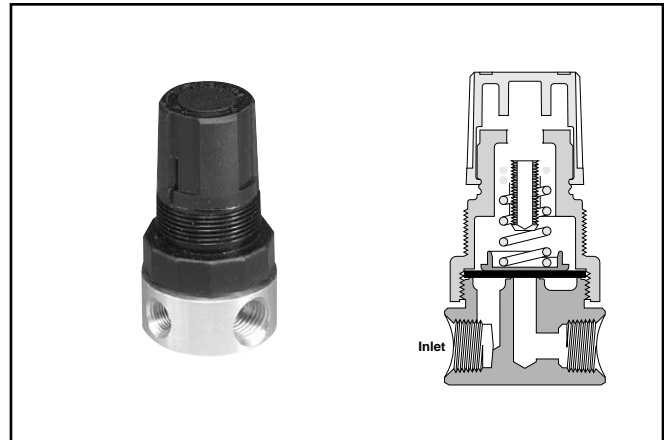

Features

- Compact, Sensitive Diaphragm-type Relief Valve
- Push-pull, Locking Knob
- Knob and Top Work the Same as a Miniature Regulator.
- 130 has Lightweight Aluminum Construction.
- 134 has a Brass Body, Captured Exhaust and is an In-line Type with 3 Inlet Ports and 1 Outlet Port

Applications

- Designed to protect against excessive pressure buildup in a pneumatic circuit or system.
- For use where gradual proportional relief is required.

Operation

- Turn relief valve knob clockwise for maximum pressure.
- Set pressure going into relief valve at desired pressure.
- Turn relief valve knob counter-clockwise until exhaust starts to bleed.
- Turn relief valve knob clockwise until exhaust stops bleeding. Push to lock knob.

Dimensions

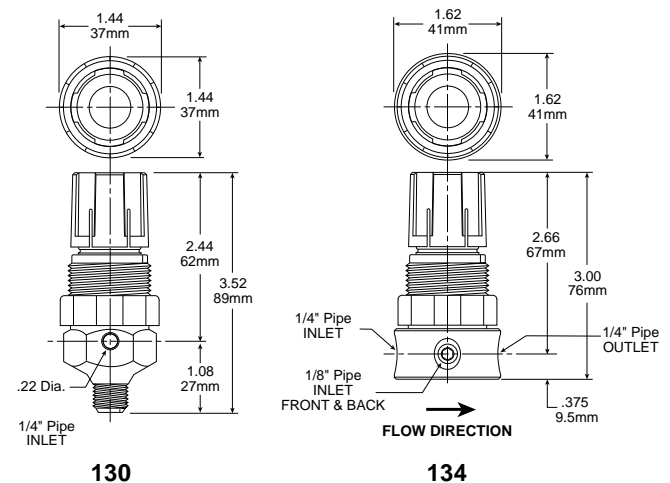

Relief Valve Kits

- Bonnet Assembly Kit PCKR364Y
- Panel Mount Nut PR05X51

Specifications

- Relief Range 0 to 100 PSIG (0 to 6.9 bar)
- Maximum Inlet Pressure 300 PSIG (20.7 bar)
- Operating Temperature 40°F to 120°F (4°C to 49°C)
- Port Threads:
- 130 1/4" Pipe Male Only
- 134 Inlet Port – Two 1/8" & One 1/4" Pipe
Outlet Port – 1/4" Pipe

Ordering Information

Relief Valve	Spring Range			
	0-15 PSIG	0-25 PSIG	0-50 PSIG	0-100 PSIG
130	130-02AA	130-02A	130-02B	130-02C
	130-02AAP*	130-02AP*	130-02BP*	130-02CP*
134	134-02AA	134-02A	134-02B	134-02C
	134-02AAP*	134-02AP*	134-02BP*	134-02CP*

* Panel mount nut included.

Materials of Construction

- Adjusting Knob Polypropylene
- Adjusting Screw Zinc-plated Steel
- Body Aluminum (130); Brass (134)
- Diaphragm / Disc Buna-N
- Nut Chromated Steel
- Spring Cage Acetal
- Spring Zinc-plated Steel



Quick Exhaust & Shuttle Valves

"0R" Series

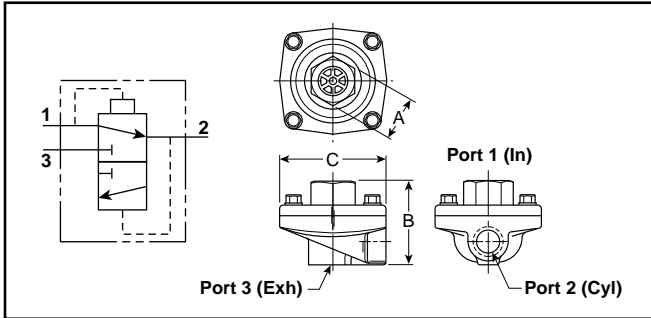
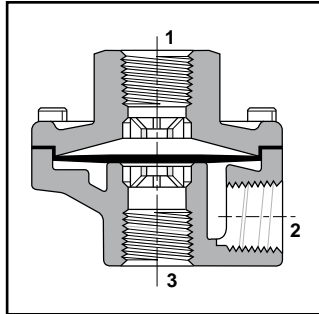

Valve Specifications

Operating Pressure (Air)

Maximum:

- 150 PSIG
- 200 PSIG for Model No. 0R37TB (PTFE diaphragm)

Minimum:

- 3 PSIG
- 50 PSIG for Model No. 0R37TB (PTFE diaphragm)

Operating Temperature:

- Urethane: 0°F to 180°F* (-18°C to 80°C)
- Nitrile: 0°F to 180°F* (-18°C to 80°C)
- Fluorocarbon: 0°F to 400°F* (-18°C to 205°C)
- PTFE: 0°F to 500°F* (-18°C to 260°C)

* Ambient temperatures below freezing require moisture-free air. Ambient temperatures below freezing and above 180° require lubricants especially selected for suitability at these temperatures. Pneumatic valves should be used with filtered and lubricated air.

Component Materials

- Body Material** Die cast aluminum
- Static Seals** Nitrile standard with urethane (Others see below)
- Diaphragm** Standard – Urethane
 Optional – Fluorocarbon, PTFE, or Nitrile (Depending on size)

General Information

Quick exhaust valves provide rapid exhaust of control air when placed between control valve and actuator. They can also be used as shuttle valves. Diaphragm materials are available in urethane, Nitrile, Fluorocarbon, and PTFE to meet a wide variety of operating conditions.

Mounting Bracket Kit – No. 03640 8100

(Including body screws)
 For "0R12" and "0R25" sizes with 7/8" "A" Dimension.

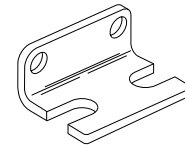

Model Selection, Performance Data and Dimensions

Port			Flow (SCFM) [†]	Model Number		A	B	C	Service Kit No.
1	2	3		NPTF	BSPP "G"				
STANDARD URETHANE DIAPHRAGMS (Nitrile static seals)									
1/4"	1/4"	3/8"	150	0R25NB	ORB25NB	1" Hex	2.06	2.44	03340 0105
		3/8"	240	0R25PB	—	1" Hex	2.06	2.44	03340 0105
3/8"	3/8"	3/8"	240	0R37B	ORB37B	1" Hex	2.06	2.44	03340 0105
1/2"	1/2"	1/2"	450	0R50B	ORB50B	1-1/2" Hex	2.88	3.38	03475 0109
3/4"	3/4"	3/4"	550	0R75B	ORB75B	1-1/2" Hex	2.88	3.38	03475 0109
NITRILE DIAPHRAGMS (Nitrile static seals)									
1/8"	1/8"	1/8"	70	0R12B	ORB12B	7/8" Sq.	1.75	1.88	03640 8000
		1/4"	70	0R12NB	ORB12NB	7/8" Sq.	1.75	1.88	03640 8000
1/4"	1/4"	1/4"	90	0R25B	ORB25B	7/8" Sq.	1.75	1.88	03640 8000
		3/8"	90	0R25NFB	ORB25NFB	7/8" Sq.	1.75	1.88	03340 8000
3/8"	3/8"	3/8"	240	0R37FB	ORB37FB	1" Hex	2.06	2.44	03340 8000
3/4"	3/4"	3/4"	550	0R75FB	ORB75FB	1-1/2" Hex	2.88	3.38	03475 9000
FLUOROCARBON DIAPHRAGMS for extended temperature operation (Fluorocarbon static seals)									
1/8"	1/8"	1/8"	70	0R12VB	ORB12VB	7/8" Sq.	1.75	1.88	03650 8000
		1/4"	70	0R12NVB	ORB12NVB	7/8" Sq.	1.75	1.88	03650 8000
1/4"	1/4"	1/4"	90	0R25VB	ORB25VB	7/8" Sq.	1.75	1.88	03650 8000
3/8"	3/8"	3/8"	240	0R37VB	ORB37VB	1" Hex	2.06	2.44	03340 0319
1/2"	1/2"	1/2"	450	0R50VB	ORB50VB	1-1/2" Hex	2.88	3.38	03475 0120
3/4"	3/4"	3/4"	550	0R75VB	ORB75VB	1-1/2" Hex	2.88	3.38	03475 0120
PTFE DIAPHRAGMS for higher pressure and temperature (Fibre static seals)									
3/8"	3/8"	3/8"	240	0R37TB	ORB37TB	1" Hex	2.06	2.44	03340 0504

† At 100 PSIG inlet pressure with full pressure drop.

BOLD ITEMS ARE MOST POPULAR.



Shuttle Valve

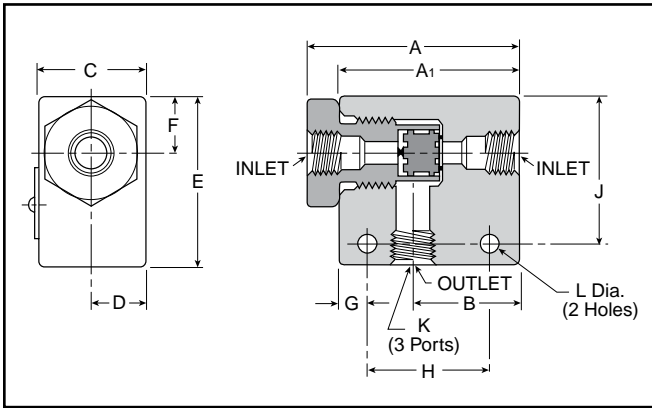
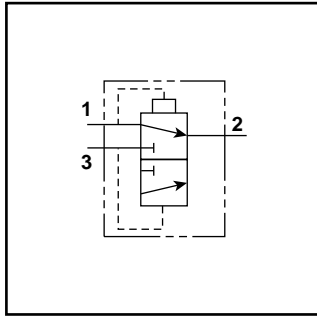
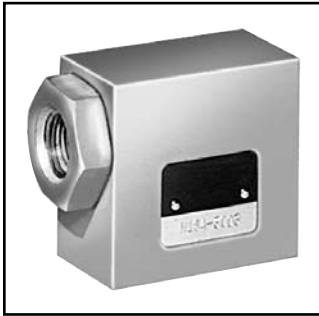

General Information

Shuttle valves determine a single pneumatic output from two separate inputs. If pressure is applied to both ports simultaneously, the valve will select the port with the higher pressure.

Valve Specifications

Maximum Operating Pressure..... 200 PSIG Maximum
 3 PSIG Minimum: Differential Pressure

Operating Temperature 0° to 160°F*

* Ambient temperatures below freezing require moisture-free air. Ambient temperatures below freezing and above 180° require lubricants especially selected for suitability at these temperatures. Pneumatic valves should be used with filtered and lubricated air.

Component Materials

Body Material Aluminum
Internal Components..... Aluminum
Seals Nitrile

Model Selection and Dimensions

Model Number	Port Size	Dimensions											
		A	A1	B	C	D	E	F	G	H	J	K	L
N164 1001	1/8"	N/A	1.62	0.81	0.62	0.31	1.00	0.281	0.312	1.00	0.75	1/8 - 27	0.219
N164 2003	1/4"	2.50	2.12	1.25	1.25	0.62	2.00	0.67	0.265	1.25	1.35	1/4 - 18	0.219
N164 3003	3/8"	2.50	2.12	1.25	1.25	0.62	2.00	0.67	0.265	1.25	1.35	3/8 - 16	0.219

Performance Data – Flow

Model Number	Port Size	Flow (Cv)
N164 1001	1/8"	0.32
N164 2003	1/4"	1.65
N164 3003	3/8"	2.02



Typical “Quick Exhaust Valve” Applications

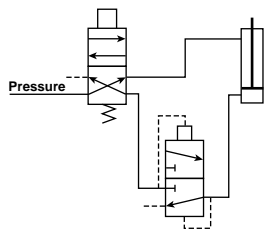

Rapid Retraction – Double Acting Cylinder

In this circuit, air is exhausted through a Quick Exhaust Valve that is **close coupled** to the cap end of the cylinder. Because the Quick Exhaust Valve has a greater exhaust capacity than the four-way Control Valve, increased cylinder speed can be accomplished with a smaller and less expensive control valve.

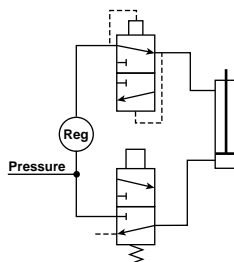

Dual Pressure Actuation of Double Acting Cylinder

This circuit utilizes a Quick Exhaust Valve and a three-way Control Valve to permit rapid extension of the cylinder at a high pressure, thus saving air and increasing cylinder life.

NOTE: Line pressure must be 3 or 4 times greater than rod end pressure. Effective working pressure is the differential between the cap and rod end.

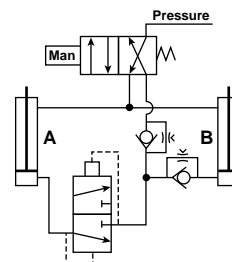

Bi-Directional Control of Two Double Acting Cylinders

This circuit provides maximum control with a minimum of valving. A large four-way Control Valve is not needed to permit the rapid retraction of Cylinder A, as the Quick Exhaust Valve performs this function. The extension of Cylinders A and B and retraction of Cylinder B are controlled by Speed Control Valves.

Typical “Shuttle Valve” Applications

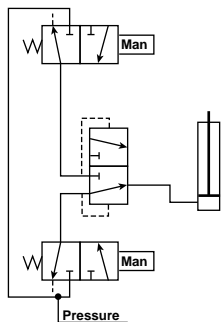

“OR” Circuit

The most common application of the Shuttle Valve is the “OR” Circuit. Here a cylinder or other work device can be actuated by either control valve. The valves can be manually or electrically actuated and located in any position.

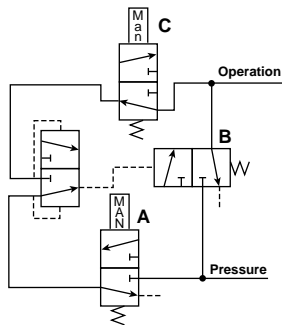

Memory Circuit

This circuit enables continuous operation once initiated. Pressure is delivered to the circuit when Valve A is actuated. This allows pressure to pass through the shuttle valve actuating Valve B. Pressure then flows through Valve B and also the other side of the shuttle valve which holds Valve B open for continuous operation. To unlock the circuit, Valve C must be opened to exhaust the circuit and allow Valve B to return to its normally closed position.

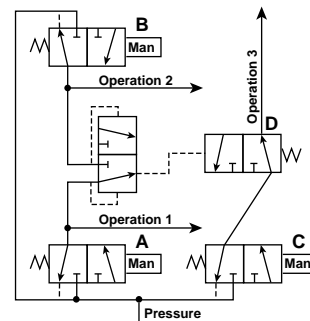

Interlock

This circuit prevents the occurrence of a specific operation while one or another operation takes place. When either Valve A or B is actuated to perform operation 1 or 2, Valve D is shifted to the closed position and prevents operation 3 from occurring.

F

WDV3-G Series



WDV3-G

The WDV3 Electrical Drain is designed to remove condensate from compressors, compressed air dryers and receivers up to any size, type or manufacturer.

The WDV3 offers true installation simplicity and it is recognized as the most reliable and best performing condensate drain worldwide. The large orifice in the direct acting valve, combined with its sophisticated timer module ensure many years of trouble-free draining of condensate.

Benefits

- Does Not Air-Lock During Operation.
- Compressed Air Systems Up to Any Size.
- Also Available In Stainless Steel.
- The Direct Acting Valve Is Serviceable.
- Suitable for All Types of Compressors.
- TEST (Micro-Switch) Feature.
- High Time Cycle Accuracy.
- Large (4.5mm) Valve Orifice.

Specifications

Operating Pressure 230 PSIG (15,9 bar)

Ambient Operating Range Temperature:
34° to 130°F (1.1° to 54°C)

Coil Insulation
Class H 340°F (171.1°C)

Voltages
AC 115, 230/50-60
DC 24

Timer:
Open Time5 to 10 sec., Adjustable
Cycle Time5 sec. to 45 min., Adjustable

Maximum Current Rating 4mA Max.

Port Size 1/4, 3/8, 1/2 NPT

Weight 1.8 lb. (0.8 kg)

Materials of Construction

Valve Body Brass / Stainless Steel

Enclosure (NEMA 4) ABS Plastic

Internal Parts Brass / Stainless Steel

Sealing Material FPM (Fluorocarbon)

Ordering Information

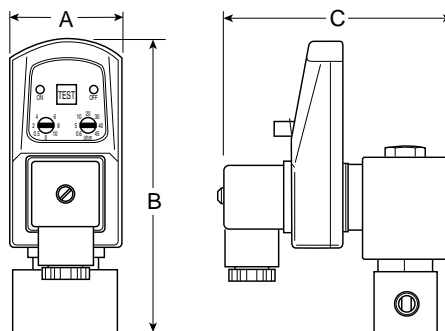
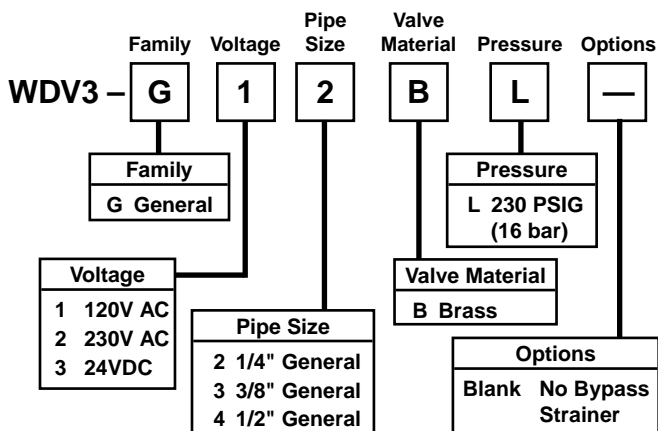

Model Selection and Dimensions

Model Number	A	B	C
WDV3-G**BL	1.73 (44)	4.53 (115)	3.46 (88)



Zero Loss Drain – WDV2



WDV2-425

Features

- Zero Air Loss.
- Automatically Self-Adjusting for Voltages from 110 to 230V.
- Sensor Device with No Moving Parts.
- Sophisticated Electronic Controls.
- Alarm with Remote Contacts.
- Large Inlet Port to Eliminate Clogging.
- Manual Push-to-Test Button.
- Automatically Clears Slugs.

Benefits

- Energy Efficient.
- World-Wide Applications.
- Long Life.
- High Reliability.
- Versatility, Early Warning.
- Low Maintenance.
- On Demand Operation.
- Maintenance Free.

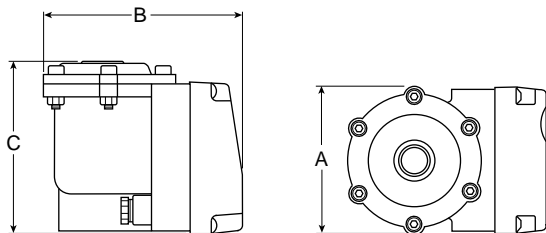

Model Selection and Dimensions

Model Number	A	B	C
WDV2-425	3.23 (82)	4.61 (117)	4.65 (118)

Specifications

- Drain Volume** 0.01 Gallons / Cycle
Maximum Fluid Temperature 150°F (60°C)
Voltage 110 to 240V, 50/60 Hz
Inlet Ports (2) 1/2" NPT
Outlet Ports (1) 5/16" (8mm) I.D. Hose

Operating Conditions

- Ambient Temperature** 33° to 140°F (0° to 60°C)
Maximum Operating Pressure 232 PSIG (16 bar)

The WDV2 Electronic Demand Drain Valves, with zero air loss, are suitable for all compressed air system applications from aftercoolers to filters to receivers to refrigerated dryers. These drain valves activate automatically and are both reliable and economical.

Alarm Mode

Should the drain fail to discharge due to an excessive volume of condensate or blocked outlet piping, an alarm condition is activated. During the alarm condition, the drain cycles continuously in an attempt to remove the excess condensate. At the same time, the volt free alarm contacts change state and the normally green power LED flashes to indicate a problem. When the excess condensate or blockage has been cleared, the drain will resume normal operation.

Operation

1. Upon power up, the outlet valve is closed and sensor is constantly monitoring for presence of liquid.
2. When condensate is detected by the sensor, the outlet valve is opened for a pre-set time.

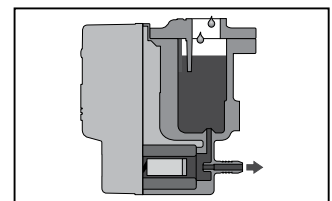
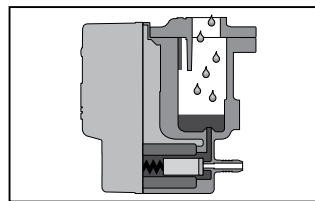

3. The condensate is discharged from the outlet port, due to the system pressure acting on the top of the liquid.
4. The outlet valve is closed after a pre-set time has expired. The opening time has been calculated to always ensure a small amount of liquid remains in bowl. This liquid acts as a seal, preventing air loss.

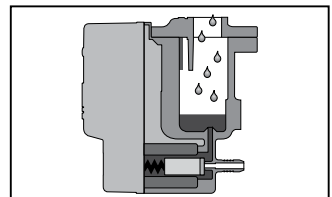
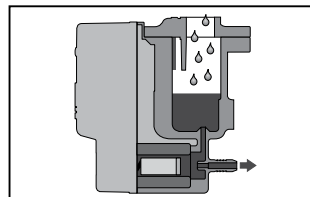

Level monitoring and discharge operation are continuous.

F

Notes

Notes



Notes

Notes





Control Panel Products

Human / Machine Dialog

Section F



Basic Features	F36-F37	Rotary Selector Switches, 22mm (7/8")	F46
Push Button, Selector Switches with Bodies	F38	Joystick Operators	F47
Push Buttons	F39	Foot Pedal Operated Switches	F48
Selector Switches	F40	Two-Hand Controls	F49-F50
Valve Bodies & Accessories	F41		
Dimensions & Assembly	F42		
Legend Plates, Specifications	F43		
Mounting	F44		
Visual Indicators 22mm (7/8")	F45		

BOLD ITEMS ARE MOST POPULAR.



Basic Features

HUMAN-MACHINE DIALOG requires devices such as push buttons and selector switches to provide command inputs. A wide variety of these devices is available to meet most application needs. Both pneumatic and electrical switch bodies are available to match system technology. All of these devices use the 22 mm (7/8") mounting standard.

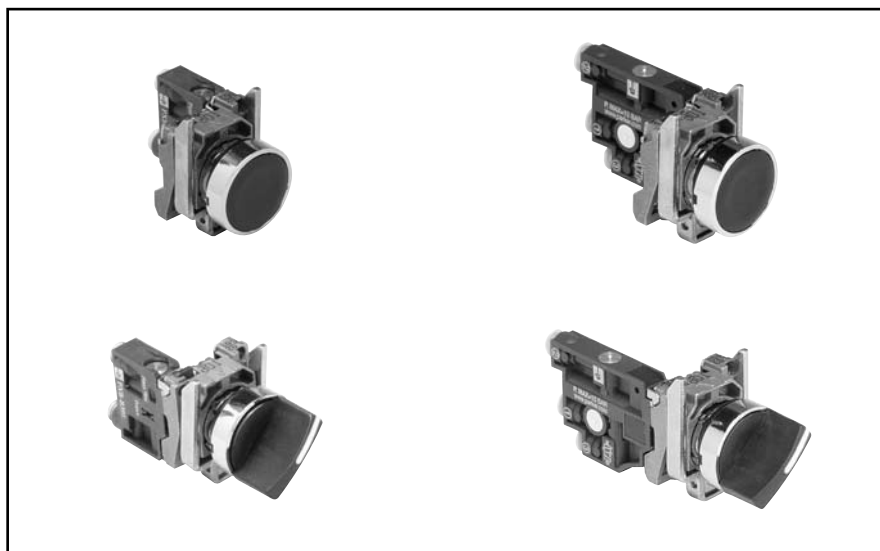

PNEUMATIC VISUAL INDICATORS

An indicator ball is rotated by a pneumatic input, changing the visible color. The ball sits behind a clear plastic window, providing a wide field of view. The visual indicators are available in five brightly colored Day-Glow paints for increased visibility. Like push buttons and selector switches, visual indicators use the 22mm (7/8") mounting standard.

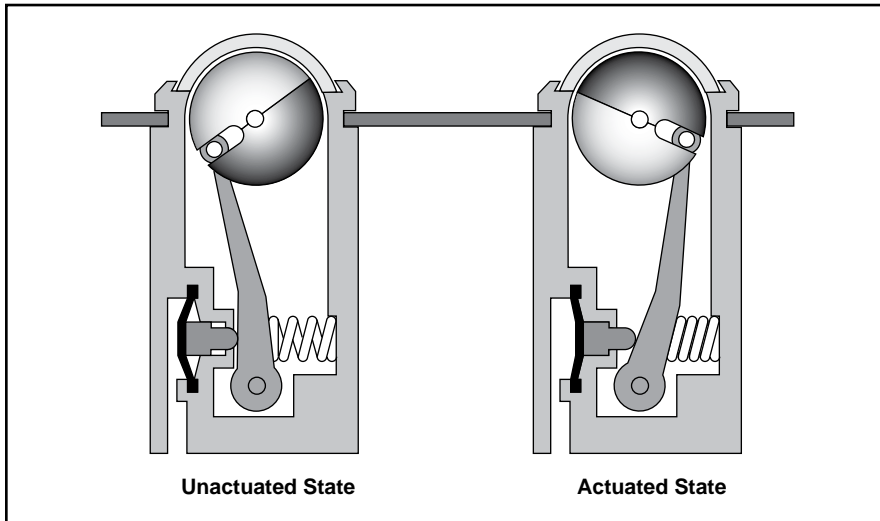

FOOT PEDAL SWITCHES

When the application requires the use of foot pedals, these devices can be used to initiate a cycle or a step within a cycle. A metal foot pedal is available with protective guard.

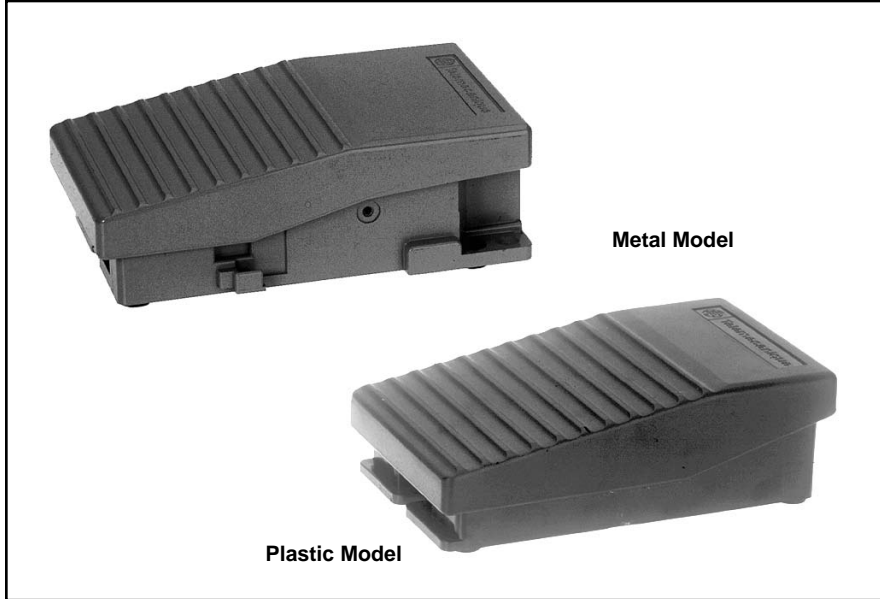

**MODULAR
 PNEUMATIC / ELECTRIC
 PUSH BUTTONS**

As with electrical contact switches, pneumatic valve modules can be mounted on a number of different operating heads.

- Pneumatic normally non passing (NNP) is equivalent to electrical normally open (N.O.).
- Pneumatic normally passing (NP) is equivalent to electrical normally closed (N.C.).

Note: Electrical switches can be stacked, but the rear connection on pneumatic switches prevents stacking. Therefore, when mixing electrical and pneumatic switch bodies on the same operator, the pneumatic switch must be mounted last.

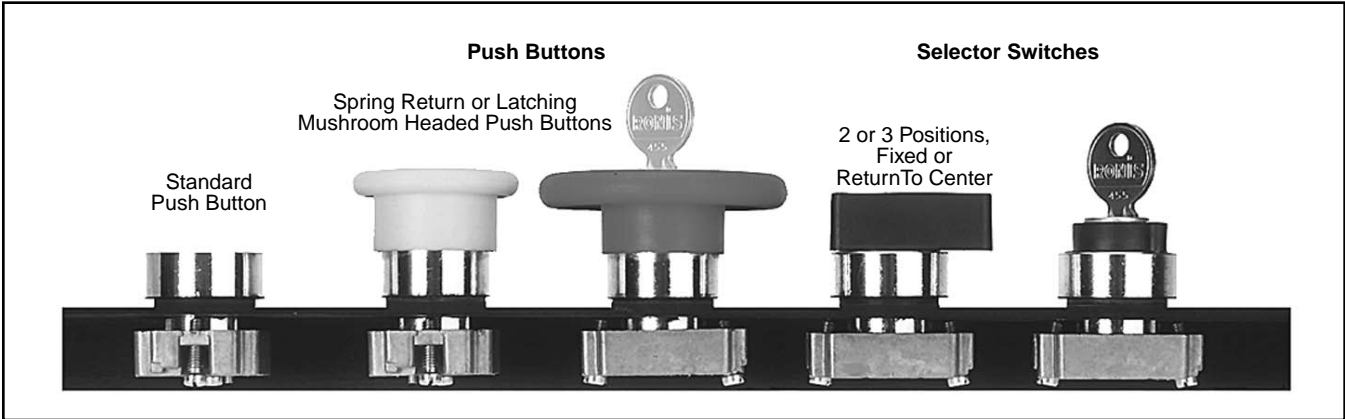

With 3/2 Valve Bodies 5/32" Instant Straight Connections

Flush Push Buttons



PXBB3111BA2



PXBB4131BA2

Part Number	Color	Function	Type of Switching*
PXBB3111BA2	Black	Spring Return	NNP
PXBB3111BA3	Green		
PXBB3111BA4	Red		
PXBB3251BA2	Black	Spring Return	NNP+NP
PXBB4131BA2	Black	Spring Return	Single Universal 3-Way
PXBB4131BA3	Green		
PXBB4131BA4	Red		
PXBB4231BA2	Black	Spring Return	Dual Universal 3-Way

* Type of switching: Universal 3-way: valve can be connected either as NP or NNP as required by connecting the primary air supply to port 1 or port 3.

Note: Mount up to three valves on mounting ring.

Selector Switches



PXBB3111BD2



PXBB4131BD2

Part Number	Color	Function	Type of Switching*
PXBB3111BD2	Black	2 Maintained	NNP
PXBB3211BD2	Black	Positions with	NNP+NNP
PXBB3251BD2	Black	Std. Handle	NNP+NP
PXBB3211BD3	Black	3 Maintained Positions with Std. Handle	NNP+NNP
PXBB3251BD3	Black		NNP+NP
PXBB3211BJ5	Black	3 Positions, Spring Return to Center with Long Handle	NNP+NNP
PXBB4131BD2	Black	2 Maintained Positions with Std. Handle	Single Universal 3-Way
PXBB4231BD2	Black	2 Maintained Positions with Std. Handle	Dual Universal 3-Way
PXBB4231BD3	Black	3 Maintained Positions with Std. Handle	Dual Universal 3-Way
PXBB4231BJ5	Black	3 Maintained Positions with Long Handle	Dual Universal 3-Way

* Type of switching: Universal 3-way: valve can be connected either as NP or NNP as required by connecting the primary air supply to port 1 or port 3.

Mushroom Head Push Buttons (40mm Diameter)



PXBB3111BC2



PXBB4131BC2

Part Number	Color	Function	Type of Switching*
PXBB3111BC2	Black	Spring Return	NNP
PXBB3111BT4	Red	Push-Pul	
PXBB3121BT4	Red	Push-Pull	NP
PXBB4131BC2	Black	Spring Return	Single Universal 3-Way
PXBB4131BT4	Red	Push-Pull	

* Type of switching: Universal 3-way: valve can be connected either as NP or NNP as required by connecting the primary air supply to port 1 or port 3.

Note: Mount up to three valves on mounting ring.

BOLD ITEMS ARE MOST POPULAR

F



For Use With PXBB Valve Bodies and ZBE Electrical Switch Bodies

Push Buttons

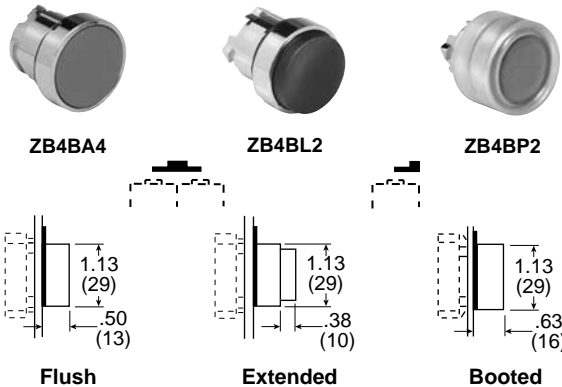

Plastic Head ZB5**	Metal Head ZB4*	Color	Function	Description
ZB5AA2	ZB4BA2	Black	Spring Return	Flush
ZB5AA3	ZB4BA3	Green		
ZB5AA4	ZB4BA4	Red		
—	ZB4BA5	Yellow		
—	ZB4BA6	Blue		
ZB5AL2	ZB4BL2	Black	Spring Return	Extended
ZB5AL3	ZB4BL3	Green		
ZB5AL4	ZB4BL4	Red		
—	ZB4BL5	Yellow		
—	ZB4BP2	Black	Spring Return	Booted
—	ZB4BP3	Green		
—	ZB4BP4	Red		

* ZB4*** Model Numbers are Metal Head Operators
** ZB5*** Model Numbers are Plastic Head Operators

Mushroom Head Push Buttons

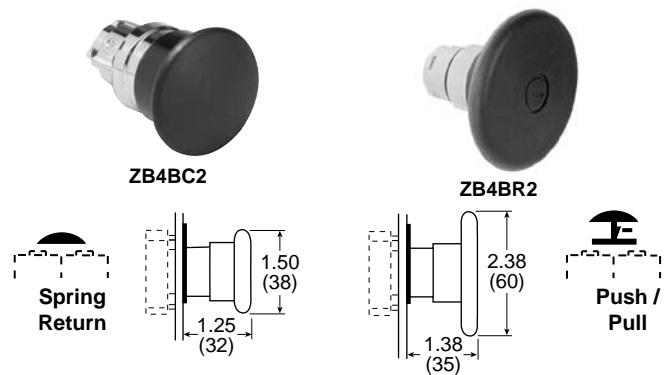

Part Number*	Color	Function	Description
ZB4BC2	Black	Spring Return	Ø 40mm Head
ZB4BC3	Green		
ZB4BC4	Red		
ZB4BT2	Black	Latching Push-Pull	
ZB4BT4	Red		
ZB4BR2	Black	Spring Return	Ø 60mm Head
ZB4BR3	Green		
ZB4BR4	Red		

* ZB4*** Model Numbers are Metal Head Operators

Mounting Accessories

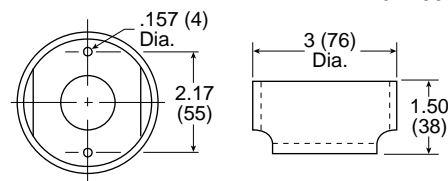
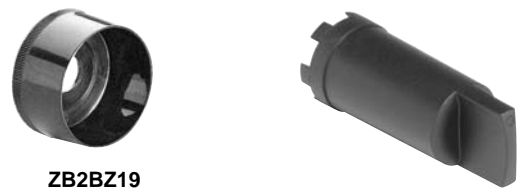

Push / Push Buttons



Part Number*	Color	Function	Description
ZB4BH02	Black	Detent 2-Position	Flush
ZB4BH03	Green		
ZB4BH04	Red		

* ZB4**** Model Numbers are Metal Head Operators

Part Number	Color	Description
ZB2BZ19	Black Plastic	Guard for 60mm Mushroom Heads
ZB5AZ905	—	Plastic Head (ZB5) Mounting Nut Tightening Tool

BOLD ITEMS ARE MOST POPULAR



For Use With PXBB Variable Composition Switch Bodies

Selector Switches



ZB4BD3



ZB4BJ3

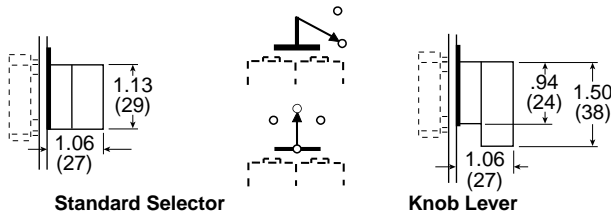

Key Operated Selectors



ZB4BG2

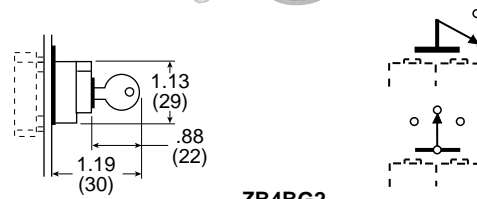

Standard Black Handle		
Part Number*	Description	Function
ZB4BD2	Maintained	2-Positions
ZB4BD4	Spring Return from Right to Left	
ZB4BD3	Maintained	3-Positions
ZB4BD5	Spring Return to Center from Left and Right	
ZB4BD7	Maintained Right Spring Return from Left to Center	
ZB4BD8	Maintained Left Spring Return from Right to Center	3-Positions
Long Black Handle		
ZB4BJ2	Maintained	2-Positions
ZB4BJ4	Spring Return from Right to Left	
ZB4BJ3	Maintained	3-Positions
ZB4BJ5	Spring Return to Center from Left and Right	

Key Operated		
Part Number*	Key Withdrawal	Function
ZB4BG2	Left	2 Maintained
ZB4BG4	Left and Right	Positions
ZB4BG3	Center	3 Maintained
ZB4BG5	Left and Right	Positions
ZB4BG7	Center	3 Positions 2 Spring Return to Center

* ZB4*** Model Numbers are Metal Head Operators

* ZB4*** Model Numbers are Metal Head Operators

Mushroom Head Push Buttons with Key Select



ZB4BS24



Part Number*	Color	Function	Description
ZB4BS54	Red	Latching Turn to Release	Ø 40mm Head
ZB4BS14	Red	Key Latching	
ZB4BS64	Red	Latching Turn to Release	Ø 60mm Head
ZB4BS24	Red	Key Latching	

* ZB4**** Model Numbers are Metal Head Operators

BOLD ITEMS ARE MOST POPULAR



For Use With 22mm (7/8") Metal Operating Heads 5/32" Instant

3/2 Valve Bodies with Mounting Ring



PXBB3111B



PXBB4131B

Part Number	Connections	Function	Type of Switching*
PXBB3111B	5/32" Instant	3/2	NNP
PXBB3121B	5/32" Instant	3/2	NP
PXBB4131B	5/32" Instant	3/2	Universal 3-Way

Note: • Mount up to 3 valves on mounting ring for push buttons.
• Mount up to 2 valves on mounting ring for selector switches,
Valves **cannot** be mounted in center position.

Specifications

- Air Quality –**
Standard Shop Air, Lubricated or Dry 40 µm Filtration
- Flow –**
PXBB3• Cv=.08
PXBB4• Cv=.18
- Materials –**
Body Polyamide
Operating Head Zinc Alloy & Plastic
- Operating Positions.....** All Positions
- Operating Pressure –**
PXBB3• 15 to 115 PSIG (1 to 9 bar)
PXBB4• 15 to 145 PSIG (1 to 10 bar)
- Ports5/32" Instant for Semi-Rigid Nylon or Polyurethane Tube**
- Temperature –**
Operating5°F to 140°F (-15°C to + 60°C)

Additional Valve Bodies



PXBB3911



PXBB4932



PXBB4931

Part Number	Connections	Function	Type of Switching*
PXBB3911	5/32" Instant Straight	3/2	NNP
PXBB3912	5/32" Instant Swivel		
PXBB3921	5/32" Instant Straight	3/2	NP
PXBB3922	5/32" Instant Swivel		
PXBB4931	5/32" Instant Straight	3/2	Universal 3-Way
PXBB4932	5/32" Instant Swivel		

Replacement Valve Bodies for PXBB1 and PXBB2 Push Button Valve Series



PXBB1911



PXBB1922



PXBB2911

Part Number	Part Number	Connections	Function	Type of Switching*
1/16" ID Body	1/8" ID Body			
PXBB1911	PXBB2911	5/32" Instant Straight	3/2	NNP
PXBB1912	—	5/32" Instant Swivel		
PXBB1915	PXBB2915	10-32 UNF Threaded	3/2	NP
PXBB1921	PXBB2921	5/32" Instant Straight		
PXBB1922	—	5/32" Instant Swivel	3/2	NP
PXBB1925	PXBB2925	10-32 UNF Threaded		
PXBB1911SE	—	5/32" Instant Straight	2/2	NNP NP
PXBB1921SE	—	5/32" Instant Swivel		

BOLD ITEMS ARE MOST POPULAR



Dimensions & Assembly

PXB-B3 Dimensions

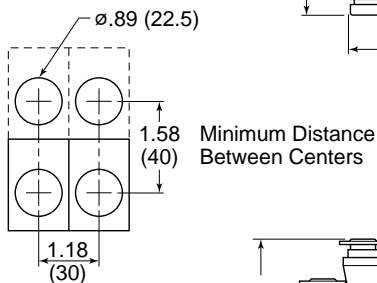
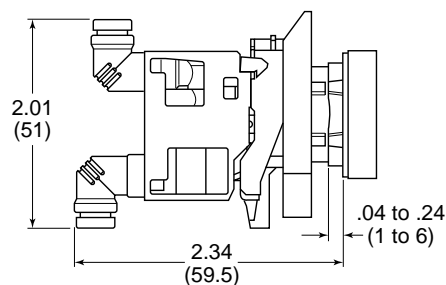
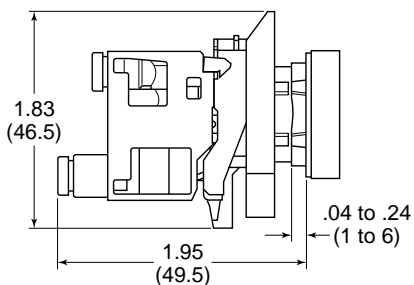

PXB-B4 Dimensions

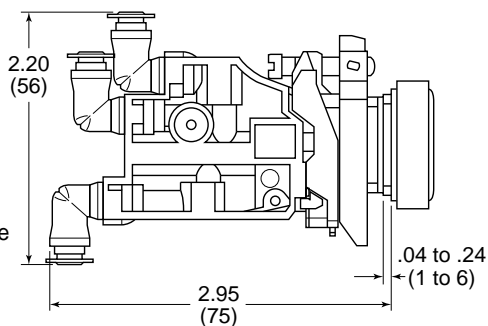
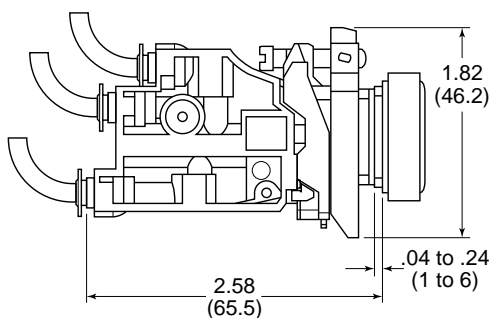

Tube Bending Radius For PXBB3 and PXBB4

- 4 mm O.D. x 2 mm I.D. Tube = Minimum 0.39 (10) Radius
- 4 mm O.D. x 2.7 mm I.D. Tube = Minimum 0.59 (15) Radius

Assembly

Assembling PXB Valves On Mounting Block

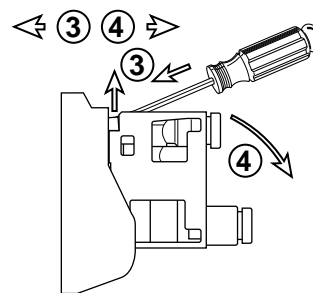
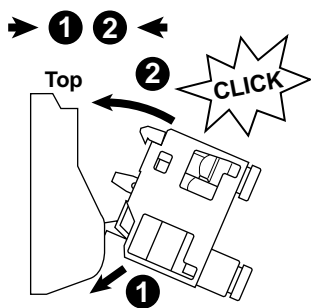

Assembling PXB Valves On the Back of the Electrical Contact

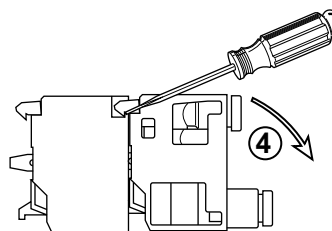
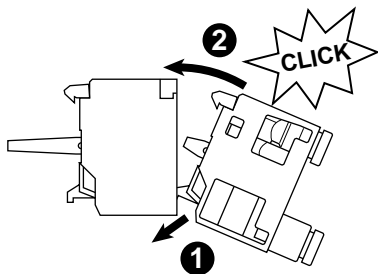

F

For Push Buttons and Visual Indicators

Legend Plates for PXBB Devices (22mm)

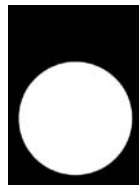

ZBY****

Part Number	Description
Without Text For Customer Engraving	
ZBY2101	Black / Red Background (White Letters)
ZBY4101	Yellow / White Background (Black Letters)
With Text For Push Buttons	
ZBY2303	Start
ZBY2304	Stop
ZBY2305	Forward
ZBY2306	Reverse
ZBY2307	Up
ZBY2308	Down
ZBY2309	Right
ZBY2310	Left
ZBY2311	On
ZBY2312	Off
ZBY2313	Open
ZBY2314	Close
ZBY2321	Inch
ZBY2323	Reset
ZBY2326	Power On
ZBY2327	Slow
ZBY2328	Fast
ZBY2330	Emergency Stop
ZBY2334	Run
With Text For 2-Position Selectors	
ZBY2367	Off On
With Text For 3-Position Selectors	
ZBY2387	Hand Off Auto

Blank Legend Plates for Inscription

For PXBB Devices (2 lines of 11 characters maximum)	
Please indicate the required text when ordering. (Allow 3 weeks for delivery)	
Part Number	Description
ZBY2002	Black Background / White Letters

For 22mm Visual Indicators Only

2 lines of 11 characters maximum

Please indicate the required text when ordering.
(Allow 3 weeks for delivery)

Part Number	Description
ZB2BY2002	Black Background / White Letters

Accessories



ZBE101

Electrical Switch Bodies

When combined with pneumatic valves, these contact blocks allow different forms of power to be provided from a single push button. Can be mounted with both types of valves PXBB3 / PXBB4.

Electrical Specification: 240V, 10Amp

Part Number	Type of Contact
ZBE101	Normally Open (NO)
ZBE102	Normally Closed (NC)

Note: Plastic Mounting Ring ZB5AZ009 to be used with ZB5 Plastic Operating Heads.

Metal Mounting Ring ZB4BZ009 to be used with ZB4 Metal Operating Heads.



Metal: ZB4BZ009



Plastic: ZB5AZ009

Mounting Ring for Valve Bodies, Switch Bodies and Operating Heads

To make up a complete push button with one to three switching elements with 5/32" instant connections, use this mounting block and select the operating heads and bodies in this Section.

Part Number	Description
ZB4BZ009	Metal Mounting Ring
ZB5AZ009	Plastic Mounting Ring

To make up a complete selector switch with one or two switching elements with 5/32" instant connections, use this mounting block and select the operating heads and bodies in this Section.

Part Number	Description
ZB4BZ009	Metal Mounting Ring
ZB5AZ009	Plastic Mounting Ring

Note: To release push button from mounting ring, pull lever on top of mounting ring up and remove push button operator. To assemble push button operator to mounting ring, align arrows and snap into place.

BOLD ITEMS ARE MOST POPULAR



Functionality Explanation

Fluid Power		Universal Description	Electrical	
Function	Symbol		Function	Symbol
Normally Closed (N.C.)		Normally Non-Passing (NNP)	Normally Open (N.O.)	
Normally Open (N.O.)		Normally Passing (NP)	Normally Closed (N.C.)	

Type of Switching: Universal 3-Way: Valve can be connected either as NP or NNP as required by connecting the primary air supply to port 1 or port 3.



- NNP: Normally Non-Passing.
- NP: Normally Passing.
- NNP + NNP: Double Switch Body, Both Normally Non-Passing.
- NNP + NP: Normally Non passing and Normally-Passing.
- NP + NP: Both Normally Passing.

Combination of Output Devices on a Single Mounting Block

Up to 3 output devices (valves or electrical contacts) can be mounted side by side on 1 mounting block.

Note: The central position can only be activated by push button heads.

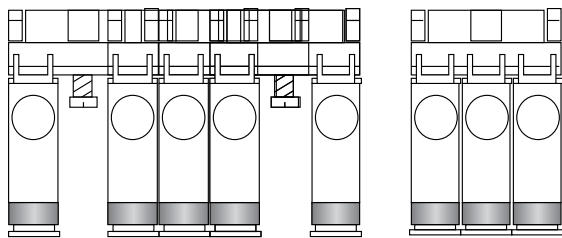

Electrical Contacts and Valves can be Combined Either Side by Side, or by Mounting the Valve on the Back of the Electrical Contact.

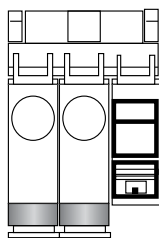

Side by Side Combination

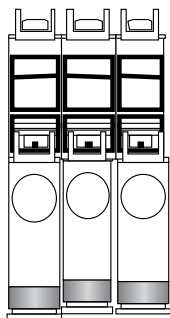

Combination by Mounting Valves On the Back of the Electrical Contact

Assembling Output Devices and Heads on ZB5 Series Mounting Block

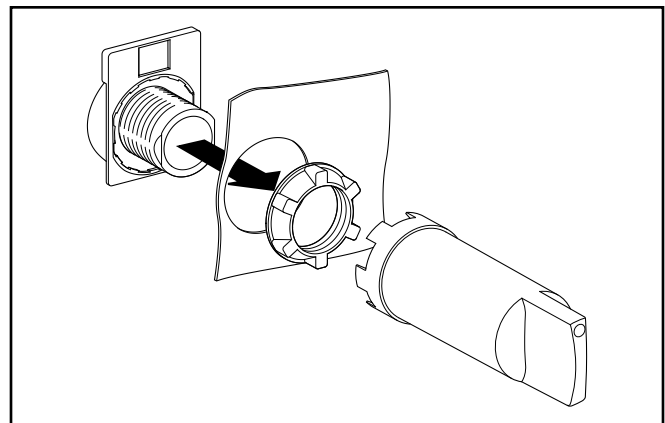

Mounting

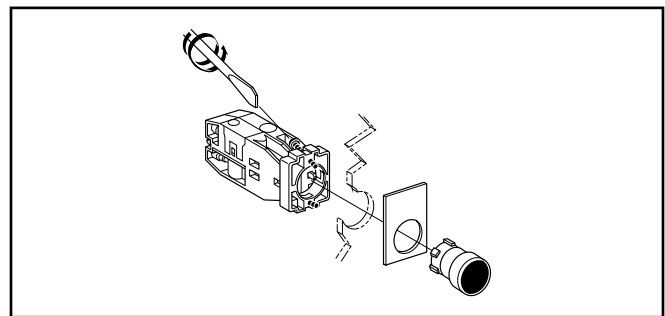

F

With 5/32" Instant Connections

22mm Visual Indicators



PXVF131

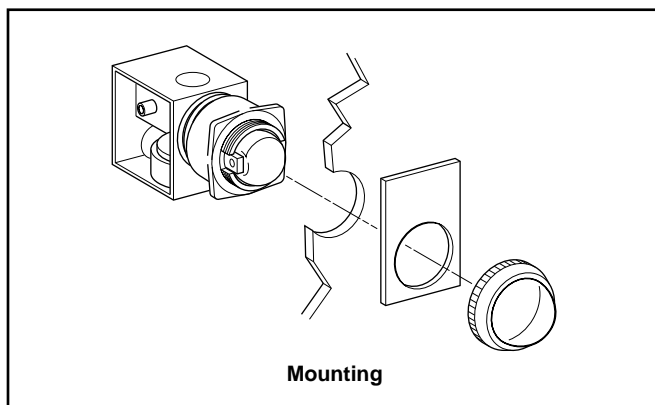

Specifications

Air Quality –

Standard Shop Air, Lubricated or Dry, 40µm Filtration

Materials –

Body..... Polyamide
 Operating Head..... Zinc Alloy & Plastic

Number of Operations with Dry Air at 90 PSI (6 bar) and 68°F (20°C) - Frequency 1 Hz.....

1 million Operations
 Mushroom Head 300,000 Operations

Operating Positions..... All Positions

Operating Pressure 15 to 115 PSIG (1 to 8 bar)

Ports –

Standard5/32" Instant for Semi- Rigid Nylon or Polyurethane Tube

10-32 UNF Available

Temperature –

Operating32°F to 122°F (0°C to + 50°C)
 Storage -22°F to 140°F (-30°C to +60°C)

Black Plastic Bezel

Part Number "ON" Indicator	Part Number "OFF" Indicator	Color
PXVF131	PXVF1213	Green
PXVF141	PXVF1214	Red
PXVF151	PXVF1215	Yellow
PXVF161	PXVF1216	Blue
PXVF111	PXVF1211	White

Notes:

- The Pneumatic Indicators are black in one position and colored in the other. The colored position corresponds either to the presence of a pressure ("ON" Indicator) or the absence of pressure ("OFF" Indicator).
- For Legend Plates, see page B9.

Dimensions

PXVF1••

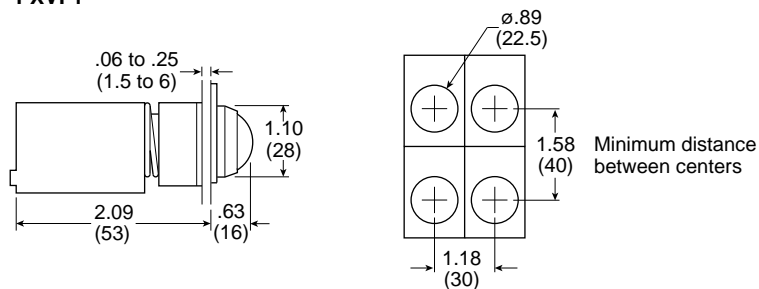

With 5/32" Instant Connections, 1/16" I.D. Internal Orifice

4-Positions, 4-Outputs 3/2

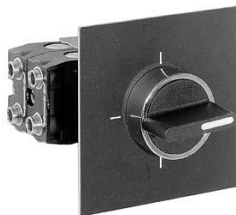
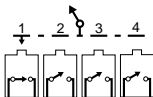
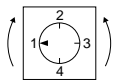

PXBDD104

Without Mechanical Stop		
Part Number	Operating Head	Type of Switching*
PXBDD104	Black Handle with 2.5" x 2.5" (64 x 64 mm) Legend Plate, Red or Black Background	NNP

Specifications

Air Quality –
 Standard Shop Air, Lubricated or Dry, 40µm Filtration

Materials –
 Body..... Polyamide
 Operating Head..... Zinc Alloy & Plastic

Minimum Operating Force 9.4 Lb (42 N)

Number of Operations with Dry Air at 90 PSI (6 bar) and 68°F (20°C) - Frequency 1 Hz..... 1 million Operations
 Mushroom Head..... 300,000 Operations

Operating Positions..... All Positions

Operating Pressure 15 to 115 PSIG (1 to 8 bar)

Ports –
 Standard: 5/32" Instant for Semi- Rigid Nylon or Polyurethane Tube
 10-32 UNF Available.

Temperature –
 Operating 32°F to 122°F (0°C to + 50°C)
 Storage -22°F to 140°F (-30°C to +60°C)

Notes:
 These Rotary Switches operate in either direction. They come assembled with switch PXBB1921 (Normally Passing). All switches are held in the actuated non-passing position except the one associated with a given dial position, which is in the unactuated Normally Passing position.

Example of Operation: Rotation from Position 1 to Position 2:

- Switch 1 changes from unactuated Normally Passing to actuated non-passing.
- Switch 2 changes from actuated non-passing to unactuated Normally Passing.

Units will accept all switch bodies shown earlier in this Section, but care must be taken in selecting switch type.

8-Positions, 8-Outputs 3/2

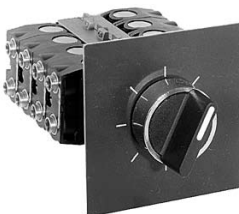
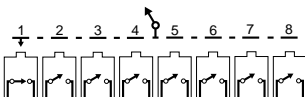
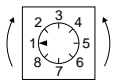

PXBDD508

Without Mechanical Stop		
Part Number	Operating Head	Type of Switching*
PXBDD508	Black Handle with 2.5" x 2.5" (64 x 64 mm) Legend Plate, Red or Black Background	NNP



With 5/32" Instant Connections, 1/16" I.D. Internal Orifice

2-Position Unit



PXBGA8211

4-Position Unit

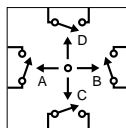

PXBGA8411

Note: These Joystick Operators come assembled with switch type PXBB1911, but will accept all Switch Bodies shown later in this Section.

Part Number	Position	Function	Type of Switching*	Operating Head
PXBGA8211	2	Maintained Position in Each Direction	NNP	Chrome Plated Lever with Protective Bellows 1.6" x 2.5"
PXBGA8411	4			
PXBGA8221	2	Spring Return in Each Direction	NNP	(40 x 64 mm) Legend Plate Red or Black Background
PXBGA8421	4			

* NNP: Normally Non-Passing.

Specifications

- Air Quality –**
Standard Shop Air, Lubricated or Dry, 40µm Filtration
- Flow at 90 PSI (6 bar) in SCFM (l/mn ANR)** 1.8 (50)
- Materials –**
Body..... Polyamide
Operating Head..... Zinc Alloy & Plastic
- Nominal Bore Ø in Inches (mm).....** 1/16" (1.5)
- Number of Operations with Dry Air at 90 PSI (6 bar) and 68°F (20°C) - Frequency 1 Hz.....** 1 million Operations
- Operating Angle.....** 18°
- Operating Positions.....** All Positions
- Operating Pressure** 15 to 115 PSIG (1 to 8 bar)
- Operating Torque** 59.5 oz-in (420 mNm)
- Ports –**
Standard: 5/32" Instant for Semi- Rigid Nylon or Polyurethane Tube
10-32 UNF Available.
- Temperature –**
Operating 32°F to 122°F (0°C to + 50°C)
Storage -22°F to 140°F (-30°C to +60°C)

Dimensions

PXBGA82**

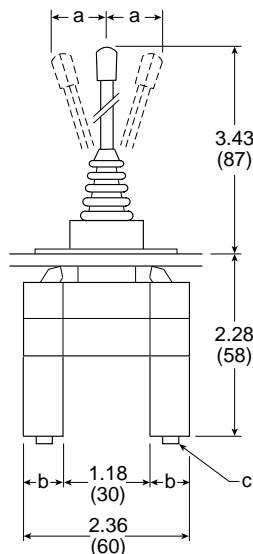

	inch	mm
a*	1.57	40
b	.59	15
c	5/32 Dia.	4 Dia.

* In both directions

PXBGA84**

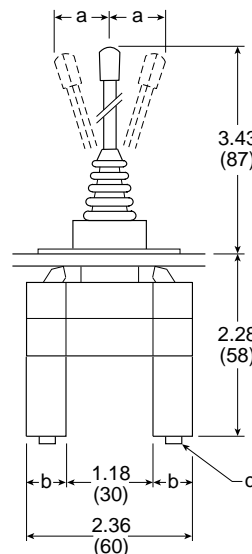

	inch	mm
a*	1.57	40
b	.59	15
c	5/32 Dia.	4 Dia.

* In all 4 directions



Standard Duty 1/6" I.D. Valves with 5/32" Instant Connections

Protective Guard



PXPEM510

Part Number	Function	Material	Type of Switching*
PXPEM510	High resistance protective guard, with interlock mechanism to prevent accidental operation by a falling object.	Metal	NNP

Foot Switches Without Protective Guard



PXPEA110

Part Number	Function	Material	Type of Switching*
PXPEA110	Spring Return	Plastic	NNP
PXPEM110	Spring Return	Metal	NNP

CAUTION:
 This valve shall not be used to actuate a punch press. Do not use this valve on punch presses or press brakes. See OSHA 1910.217.

Dimensions

PXPEM510

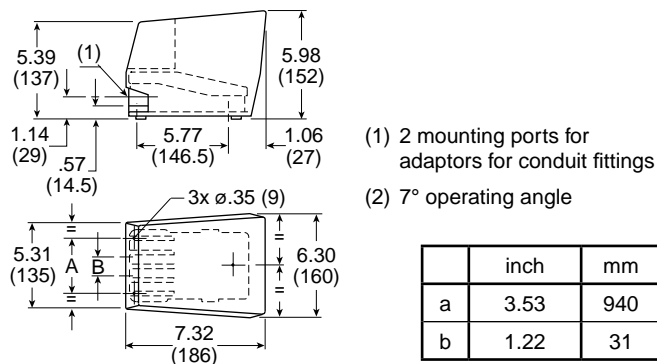

Notes: These Foot Pedal Operators come assembled with switch PXBB1921 (Normally Passing). With the pedal in the unoperated position, the switch is in the actuated non-passing position. With the pedal actuated, the switch is in the unactuated Normally Passing position.

Units will accept all switch bodies shown earlier in this Section, but care must be taken in selecting switch type.

Dimensions

PXPEM110

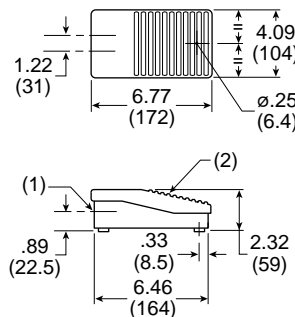

PXPEA110

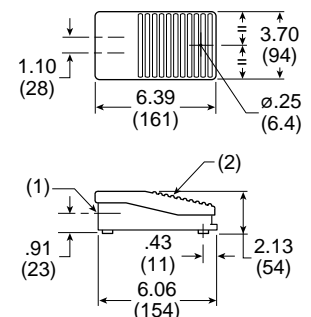

Specifications

- Air Quality –**
 Standard Shop Air, Lubricated or Dry, 40µm Filtration
- Flow at 90 PSI (6 bar) in SCFM (l/mn ANR) 1.8 (50)**
- Materials –**
 Body..... Polyamide
 Operating Head..... Zinc Alloy & Plastic
- Nominal Bore Ø in Inches (mm) 1/16" (1.5)**
- Number of Operations with Dry Air at 90 PSI (6 bar) and 68°F (20°C) - Frequency 1 Hz..... 1 million Operations**

- Operating Positions..... All Positions**
- Operating Pressure 15 to 115 PSIG (1 to 8 bar)**
- Ports –**
 5/32" Instant for Semi-Rigid Nylon or Polyurethane Tube
- Temperature –**
 Operating 32°F to 122°F (0°C to + 50°C)
 Storage -22°F to 140°F (-30°C to + 60°C)

* NNP: Normally Non-Passing.

F



Pre-Assembled Two-Hand Control Enclosure

Features

- The pre-assembled two-hand control enclosure occupies both hands of an operator by requiring nearly simultaneous operation of two pushbuttons
- Poppet – snap-acting (no spools)
- Same air as in cylinders – Filtration: 40 micron
- No lubrication required



PXPC111

Part Number	Connections
PXPC111	5/32" Instant

Operation

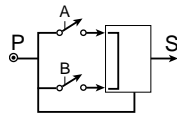

- Output "S" will appear only if "A" and "B" are simultaneously operated (within .5 seconds or less of each other).
- If the operator actuates only one pushbutton, either "A" or "B", or if both "A" and "B" are actuated but at an interval greater than .5 seconds, output "S" will not appear.
- Output "S" is regenerated by supply "P". Output "S" will therefore disappear if supply "P" is cut off.
- Output "S" will disappear if either "A" or "B" is released.
- If output "S" disappears for any reason, "A" and "B" must be nearly simultaneously actuated to again provide output "S".
- Since output "S" is regenerated it appears sharply, at full force (snap-acting), and is quickly exhausted upon deactivation. In addition the module is not affected by the length or diameter of tubing used for output "S".

General Characteristics

- Operating Pressure**40 to 120 PSI (3 to 8 bar)
- Permissible Fluids –**
Air or neutral gas 40 micron filtration, lubricated or dry
- Flow at 90 PSI (6 bar)** 7 SCFM (200 l/mn ANR)
- Operating Temperature** -5°F to 140°F (-15°C to 60°C)
Below 40°F (5°C), an air dryer is required
- Storage Temperature** -40°F to 160°F (-40°C to 70°C)
- Number of operations with dry air at 90 PSI (6 bar), 68°F (20°C), frequency 1 Hz** 1 Million Operations
- Vibration resistance –**
Conforms to section 19-2 of bureau Véritas regulations (November 1987)

Materials –

- Body..... Glass Filled Nylon
- Operating Head Zinc Alloy and Plastic

Connections..... 5/32" instant

Mounting

Approvals:

- In accordance with European Standard EN 574 - September 1996
- Conforms to the model that has obtained CE Type Test Certificate No. 02526 520 4631 0397

⚠ WARNING

These devices should NOT be used in any application involving rotary clutch presses. Two hand control modules do not of themselves insure the safety of any machine. Users and original equipment manufacturers are responsible for making sure that installations meet all relevant safety regulations.

Dimensions

Inches (mm)

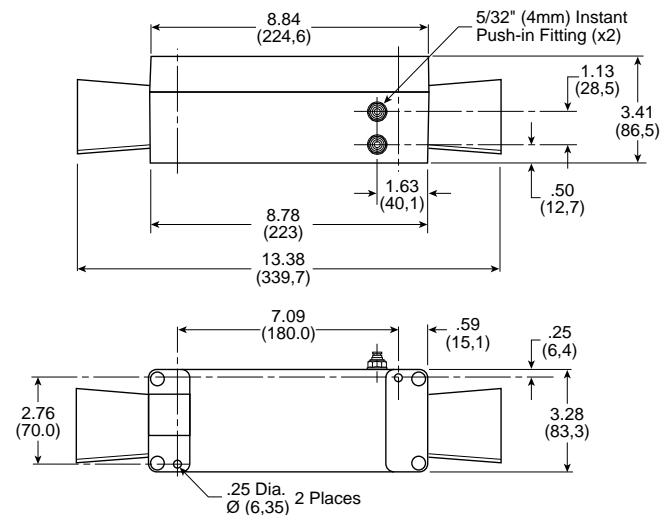

Control Module & Repair Parts

Two-Hand Control Module

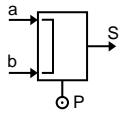

PXPA11

Part Number	Connections
PXPA11	5/32" Instant

Dimensions

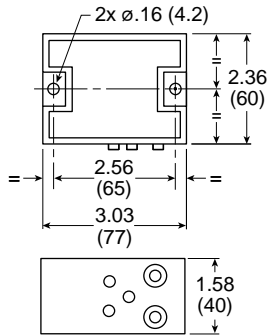

PXPA11

Specifications

- Air Quality –**
 Standard Shop Air, Lubricated or Dry, 40µm Filtration
- Flow at 90 PSI (6 bar) in SCFM (l/mn ANR) 7 (200)**
- Materials –**
 Body..... Polyamide
 Operating Head..... Zinc Alloy & Plastic
- Nominal Bore Ø in Inches (mm) 7/64" (2.5)**
- Number of Operations with Dry Air at 90 PSI (6 bar) and 68°F (20°C) - Frequency 1 Hz 1 million Operations**
- Operating Positions..... All Positions**
- Operating Pressure 40 to 115 PSIG (3 to 8 bar)**
- Ports –**
 5/32" Instant for Semi-Rigid Nylon or Polyurethane Tube
- Temperature –**
 Operating 32°F to 122°F (0°C to + 50°C)
 Storage -22°F to 140°F (-30°C to + 60°C)
- Vibration resistance:**
 Conforms to section 19-2 of bureau Véritas regulations (November 1987)

WARNING

These devices should **NOT** be used in any application involving rotary clutch presses. Two hand control modules do not of themselves insure the safety of any machine. Users and original equipment manufacturers are responsible for making sure that installations meet all relevant safety regulations.

Notes: These two-hand control modules provide an output signal upon nearly concurrent operation of two pushbuttons.

Two-Hand Control Module Guard



PPRL15

Part Number	Base Component
PPRL15	PXPC111

Two Hand Repair Parts

Part Number	Quantity Required	Description
PXPA11	1	Control Module
PXBB3111B	2	Valve Body & Mounting Ring
ZB4BR*	2	Push Button
PPRL15	2	Control Module Guard

* 2 = Black, 3 = Green, 4 = Red

Section F



Basic Features – Pneumatic Sensors F52

Limit Switches

- 3/2 Miniature Limit SwitchesF53-F54
- 3/2 Compact Limit Switches.....F55-F56
- “K” Series – Standard Duty Limit Switches...F57-F60
- “J” Series – Heavy Duty Limit Switches.....F61-F63

PWBA Blocking ValvesF64-F65

Threshold SensorsF66-F68



Basic Features

To achieve the sensing or feedback function, pneumatic sensors can be:

- Limit Switches in a Variety of Sizes and Configurations
- Pressure Switches with Many Adjustable Ranges
- Components Designed Specifically for Pneumatic Technology using Pressure Variation, Air Bleed or Blocking for Detection.

A wide variety of pneumatic sensors are available to suit any application requirement.

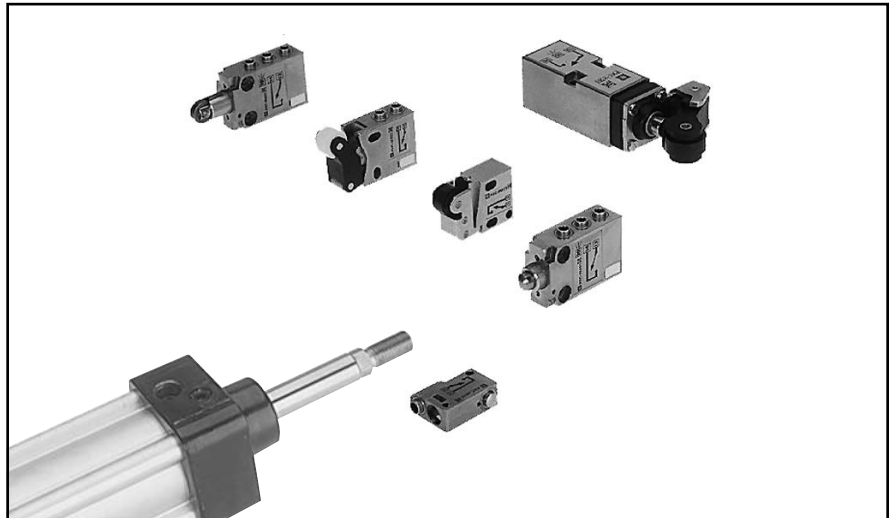

**PNEUMATIC
LIMIT
SWITCHES**

Pneumatic limit switches are non-passing (NNP) or passing (NP) when actuated by a moving part. The various operating levers, bore dimensions and functions are given below.

Interchangeable with an Electrical Microswitch

1/16" Bore 1/16" Bore 7/64" Bore

Normally Non-Passing (NNP) Models

Multiple Operating Heads

1/8" Bore Connectable Exhaust 1/8" Bore Connectable Exhaust

NNP or NP, as Required



3/2 Miniature Limit Switches

Direct Acting Limit Switches

1/16" I.D. Internal Orifice



PXCM111



PXCM121

Part Number	Connection	Actuator	Type of Switching*
PXCM111	5/32" Instant	Steel Plunger Operating Levers Available (See Below)	NNP
PXCM115	10-32 UNF		
PXCM121	5/32" Instant	Plastic Roller	NNP
PXCM125	10-32 UNF		

7/64" I.D. Internal Orifice



PXCM521

Part Number	Connection	Actuator	Type of Switching*
PXCM521	5/32" Instant	Plastic Roller	NNP

Specifications

Air Quality –

Standard Shop Air, Lubricated or Dry, 40µm Filtration

Flow SCFM (NI/min) –

PXCM111	2.2 (60)
PXCM121	3.0 (85)
PXCM521	8.8 (250)

Materials –

Body	Zinc Alloy
Poppets	Polyurethane
Seals	Nitrile (Buna N)

Maximum Operating Frequency 5 Hz

Nominal Bore Ø –

PXCM111, PXCM121	1/16" (1.5 mm)
PXCM521	7/64" (2.5 mm)

Number of Operations with Dry Air at 90 PSI (6 bar) and 68°F (20°C) – Frequency 1 Hz 10 Million

Operating Positions All Positions

Operating Pressure 40 to 115 PSIG (3 to 8 bar)

Ports –

5/32" Instant for Semi-Rigid Nylon or Polyurethane Tube

10-32 UNF Available

Temperature –

Operating 32°F to 122°F (0°C to + 50°C)

Storage -22°F to 140°F (-30°C to + 60°C)

3/2 Miniature Limit Switch Operator Specifications

	PXCM111	PXCM121	PXCM521
Differential Travel at 90 PSI (6 bar)	.006" (0.15 mm)	.012" (0.3 mm)	.020" (0.5 mm)
Maximum Travel (B) at 90 PSIG (6 bar)	.055" (1.4 mm)	.126" (3.2 mm)	.228" (5.8 mm)
Minimum Pre-Travel (A) at 90 PSIG (6 bar)	.035" (0.9 mm)	.079" (2 mm)	.087" (2.2 mm)
Minimum Operating Force at 90 PSI (6 bar)	2.5 lb (11 N)	1.0 lb (4.5 N)	1.6 lb (7 N)
Operating Diagram			

Dimensions

PXCM111

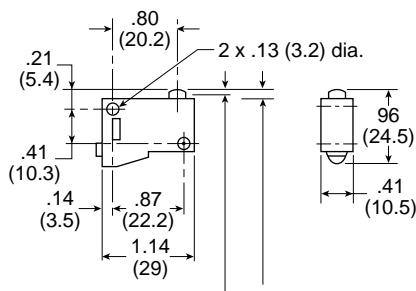

PXCM121

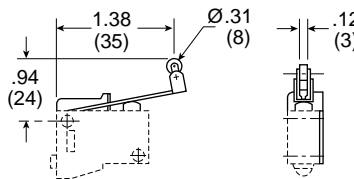

PXCM521

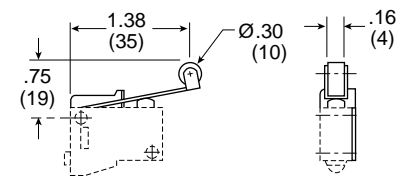

PXCM121, PXCM131

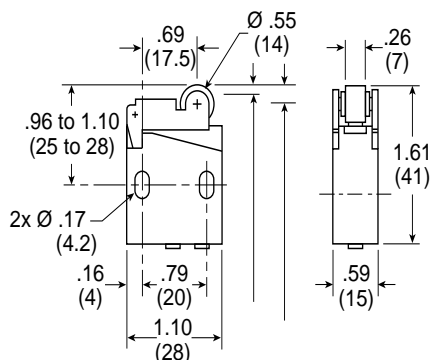

PXCM521

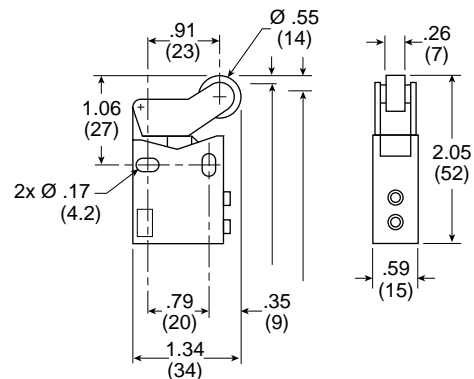

F

3/2 Compact Limit Switches

Pilot Operated Compact Limit Switches

5/32" Instant Connections
 Pipeable Exhaust Port
 7/64" I.D. Internal Orifice

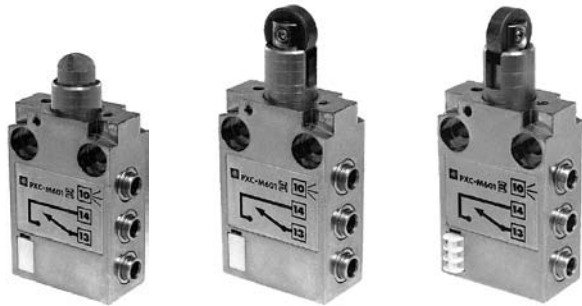

PXCM601A110

PXCM601A102

PXCM601A103

Part Number	Actuator	Type of Switching*
PXCM601A110	Steel Plunger Operating Levers Available (See Below)	NNP
PXCM601A102	Steel Roller Plunger	
PXCM601A103	90° Steel Roller Plunger	

Specifications

- Air Quality –**
 Standard Shop Air, Lubricated or Dry, 40µm Filtration
- Flow SCFM (NI/min).....** 8.8 (250)
- Materials –**
 Body..... Zinc Alloy
 Poppets..... Polyurethane
 Seals..... Nitrile (Buna N)
- Maximal Operating Frequency.....** 5 Hz
- Nominal Bore Ø.....** 7/64" (2.5 mm)
- Number of Operations with Dry Air at 90 PSI (6 bar) and 68°F (20°C) – Frequency 1 Hz.....** 10 Million
- Operating Positions.....** All Positions
- Operating Pressure.....** 40 to 115 PSIG (3 to 8 bar)
- Ports –**
 5/32" Instant for Semi-Rigid Nylon or Polyurethane Tube
- Temperature –**
 Operating..... 32°F to 122°F (0°C to + 50°C)
 Storage..... -22°F to 140°F (-30°C to + 60°C)

Actuators For Steel Plunger



XCMZ24

Use with PXCM601A110

Part Number	Actuator
XCMZ24	90° Stainless Steel Roller Lever, One Way Trip

* NNP: Normally Non-Passing.



3/2 Compact Limit Switch Operator Specifications

	PXCM601A110	PXCM601A102	PXCM601A103	PXCM601A110 + XCMZ24
Differential Travel at 90 PSI (6 bar)	.012" (0.3 mm)	.008" (0.2 mm)	.020" (0.5 mm)	.047" (1.2 mm) (A)
Maximum Travel (B) at 90 PSIG (6 bar)	.197" (5 mm)	.197" (5 mm)	.197" (5 mm)	—
Minimum Pre-Travel (A) at 90 PSIG (6 bar)	.066" (1.7 mm)	.066" (1.7 mm)	.066" (1.7 mm)	.370" (9.4 mm) (A)
Minimum Operating Force at 90 PSI (6 bar)	5.4 lbf (24 N)	5.2 lbf (23 N)	5.2 lbf (23)	4.3 lbf (19)
Operating Diagram				<p>A = cam travel</p>

Dimensions

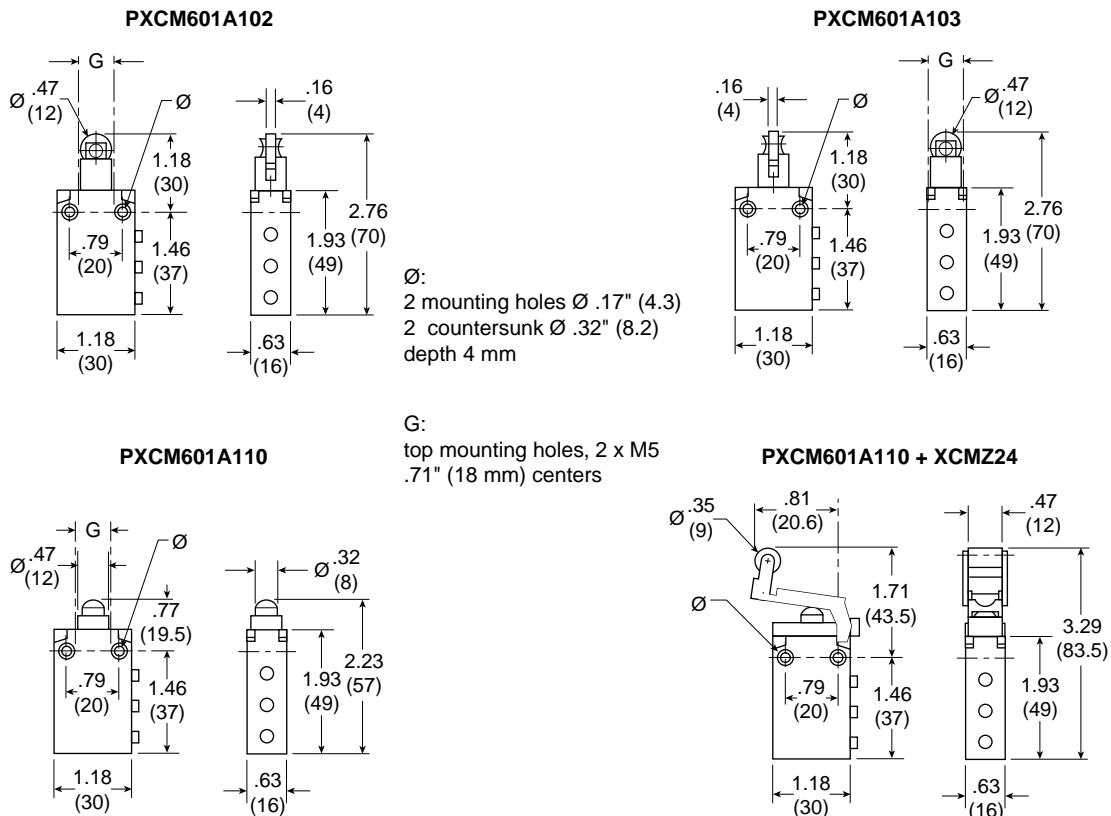

F



“K” Series Limit Switches

Plunger Operated
 5/32" Instant Connections
 Pipeable Exhaust Port
 1/8" I.D. Internal Orifice

Roller Operated
 5/32" Instant Connections
 Pipeable Exhaust Port
 1/8" I.D. Internal Orifice

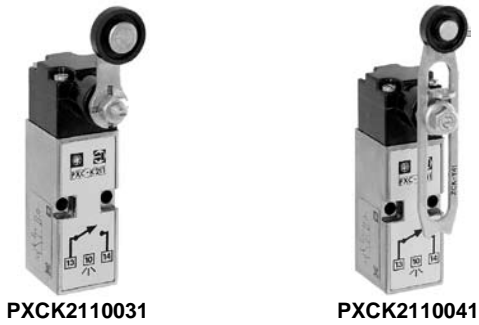

Complete Assemblies		
Part Number	Actuator	Type of Switching*
PXCK21101	Steel Plunger	NNP
PXCK22101		NP
PXCK21102	Steel Roller Plunger	NNP
PXCK22102		NP
PXCK21121	Plastic Roller Plunger	NNP
PXCK22121		NP
PXCK21106	Cats Whisker	NNP
PXCK22106		NP

With Die Cast Rotary Operating Head and Operating Lever - Complete Assemblies		
Part Number	Actuator	Type of Switching*
PXCK2110031	Fixed Delrin Roller Lever Multi-Function Head Actuates: - From Right and Left - From Right - From Left	NNP
PXCK2210031		NP
PXCK2110041	Adjustable Delrin Roller Lever Multi-Function Head Actuates: - From Right and Left - From Right - From Left	NNP
PXCK2210041		NP

NNP: Normally Non-Passing

NP: Normally Passing

Field Conversion of Rotary Operating Head

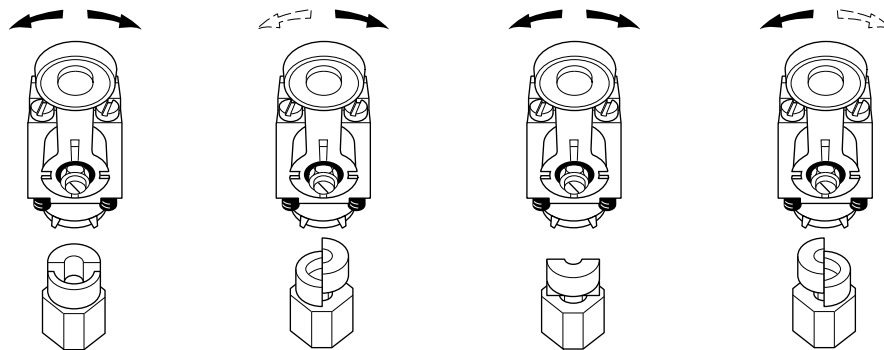

“K” Series Limit Switches

Separate Pneumatic Switch Bodies



PXCK211

Part Number	Actuator	Type of Switching*
PXCK211	For Use with ZCK Series Operating Heads	NNP
PXCK221		NP

Pneumatic Switch Bodies with Rotary Heads



PXCK21100

Part Number	Actuator	Type of Switching*
PXCK21100	Multi-Function Head Actuates: - From Right and Left - From Right - From Left	NNP
PXCK22100		NP

Operating Heads

For Use With PXCK Switch Bodies



ZCKG00

Part Number	Actuator	Description
Rotary Operated		
ZCKG00	—	Die Cast Zinc
Plunger Operated		
ZCKD02	Roller Plunger	Plunger Operated
ZCKD06	Whisker	
ZCKD10	Rod Plunger	
ZCKD21	Delrin Roller Lever On Plunger	
ZCKD23	Steel Roller Lever On Plunger	

Operating Levers for Rotary Heads



ZCKY81



ZCKY91

For Use With Rotary Head ZCKG00		
Part Number	Actuator	Description
ZCKY51	Steel 1/8" Square	Rod Levers
ZCKY52	Fiberglass 1/8" Dia. Round	
ZCKY81	Plastic Spring Rod Lever	
ZCKY91	Metal Spring Rod Lever	
ZCKY11	Delrin Roller Lever	Roller Levers
ZCKY13	Steel Roller Lever	
ZCKY41	Adjust. Delrin Roller Lever	
ZCKY43	Adjust. Steel Roller Lever	

F

Specifications

Air Quality –

Standard Shop Air, Lubricated or Dry, 40µm Filtration

Flow SCFM (NI/min)..... 7.4 (210)

Materials –

Body..... Zinc Alloy

Poppets..... Polyurethane

Seals..... Nitrile (Buna N)

Maximal Operating Frequency 5 Hz

Nominal Bore Ø 1/8" (3 mm)

Number of Operations with Dry Air at 90 PSI (6 bar) and 68°F (20°C) – Frequency 1 Hz..... 10 Million

Operating Positions..... All Positions

Operating Pressure 40 to 115 PSIG (3 to 8 bar)

Ports –

5/32" Instant for Semi-Rigid Nylon or Polyurethane Tube

Temperature

Operating 32°F to 122°F (0°C to + 50°C)

Storage -22°F to 140°F (-30°C to +60°C)

Operator Specifications

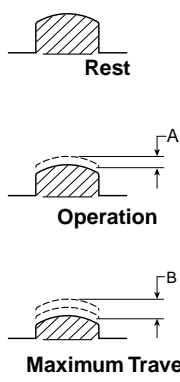
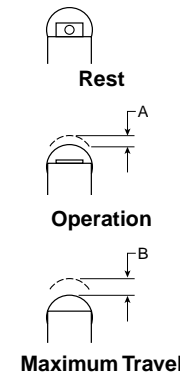
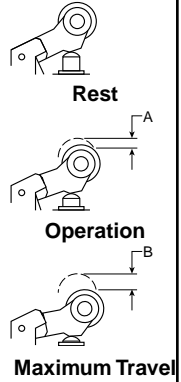
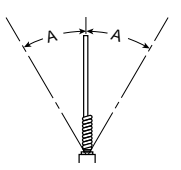
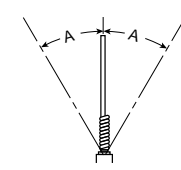
	PXCK2••01	PXCK2••02	PXCK2••03	PXCK2••06	PXCK2••00 + Actuator
Differential Angle	—	—	—	12°	3°
Differential Travel	.008" (0.2 mm)	.008" (0.2 mm)	.008" (0.2 mm)		
Maximum Angle of Travel	—	—	—	—	80°
Maximum Travel (B) at 90 PSIG (6 bar)	.020" (0.5 mm)	.020" (0.5 mm)	.020" (0.5 mm)	—	—
Minimum Pre-Travel (A) at 90 PSIG (6 bar)	.087" (2.2 mm)	.087" (2.2 mm)	.102" (2.6 mm)	—	—
Minimum Operating Force at 90 PSI (6 bar)	3.6 lbf (16N)	4.5 lbf (20N)	3.4 lbf (15N)	—	—
Minimum Operating Torque at 90 PSI (6 bar)	—	—	—	17.0 oz in (120mNm)	29.8 oz in (210mNm)
Operating Angle	—	—	—	35°	31° (Minimum Lever Travel Including Pre-Travel Required For Operation)
Operating Diagram					



Dimensions

PXCK21101, PXCK22101

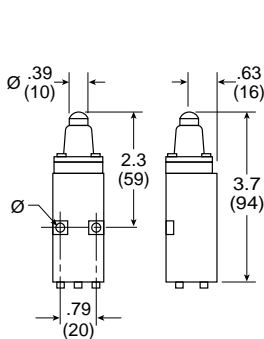

PXCK21102, PXCK22102

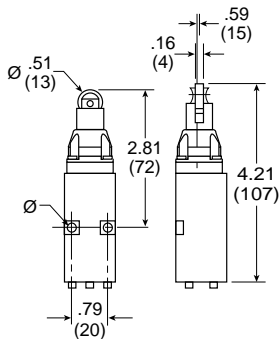

PXCK21121, PXCK22121

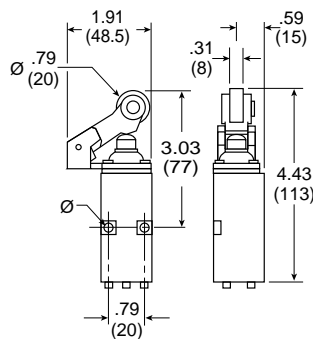

PXCK21106, PXCK22106

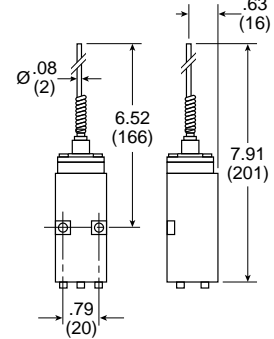

PXCK2110531, PXCK2210531

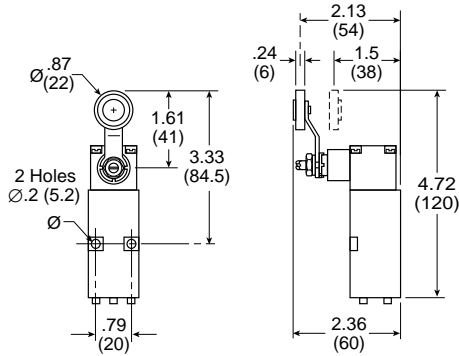

PXCK2110541, PXCK2210541

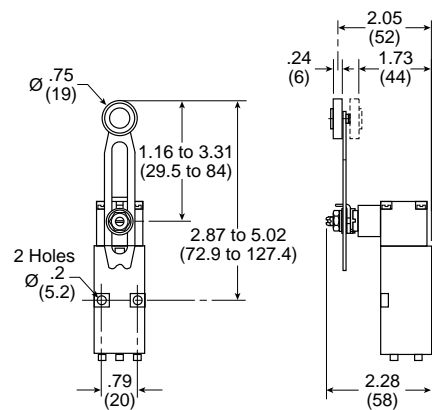

Pneumatic Switch Bodies

PXCK211, PXCK221

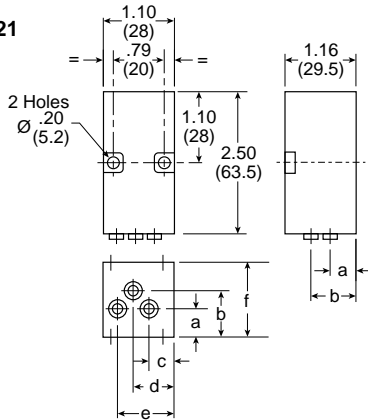

	inch	mm
a	.39	10
b	.77	19.5
c	.35	9
d	.61	15.5
e	.87	22
r	1.66	29.5

F

Rotary Heads with Operating Levers

ZCKY81

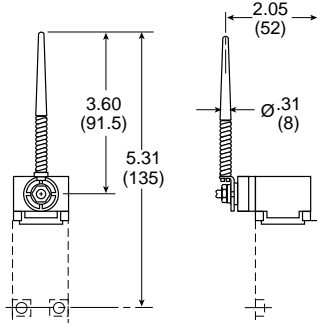

ZCKY91

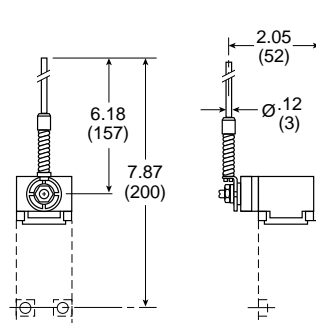

“J” Series Limit Switches

Switch Bodies Only



PXCJ117

Part Number	Type of Switching*
PXCJ117	NNP
PXCJ127	NP

Switch Bodies with Rotary Head



PXCJ11701

Part Number	Direction of Actuation	Type of Switching*
PXCJ11701	Right & Left, Spring Return	NNP
PXCJ11705	Right or Left, Spring Return	
PXCJ12701	Right & Left, Spring Return	NP
PXCJ12705	Right or Left, Spring Return	

Operating Levers for Rotary Heads



ZC2JY11



ZC2JY31



ZC2JY81



ZC2JY91

Die Cast Zinc. For Use With PXCJ Switch Bodies		
Part Number	Operator	Description
ZC2JY11	Delrin Roller	Spring Return
ZC2JY13	Steel Roller	
ZC2JY21	Offset Delrin Roller	
ZC2JY81	Plastic Spring Rod	
ZC2JY91	Metal Spring Rod	
ZC2JY31	Delrin Roller	Adjustable Roller
ZC2JY41	Offset Delrin Roller	
ZC2JY51		Rod Lever
ZC2JY71	Single Track, Delrin Roller	Fork Lever
ZC2JY61	Double Track, Delrin Rollers	

NNP: Normally Non-Passing

NP: Normally Passing

Top Plunger & Rotary Operating Heads



ZC2JE70



ZC2JE01

Die Cast Zinc. For Use With PXCJ Switch Bodies		
Top Plunger Type		
Part Number	Operation	Description
ZC2JE61	Top Push	Spring Return
ZC2JE62	Top Roller Push	
ZC2JE63	Side Push	
ZC2JE70	Cat's Whisker	
Rotary Type		
ZC2JE01	From Left & Right	Spring Return
ZC2JE02	Counterclockwise From Right	
ZC2JE03	Clockwise From Left	
ZC2JE05	From Left or Right	
ZC2JE09	Maintained Positions	



Specifications

Air Quality –

Standard Shop Air, Lubricated or Dry, 40µm Filtration

Flow SCFM (NI/min)..... 7.4 (210)

Materials –

Body..... Zinc Alloy

Poppets..... Polyurethane

Seals..... Nitrile (Buna N)

Maximal Operating Frequency 5 Hz

Nominal Bore Ø 1/8" (3 mm)

Number of Operations with Dry Air at 90 PSI (6 bar) and

68°F (20°C) – Frequency 1 Hz..... 10 Million

Operating Positions..... All Positions

Operating Pressure 40 to 115 PSIG (3 to 8 bar)

Ports 1/8" NPT

Temperature –

Operating 32°F to 122°F (0°C to + 50°C)

Storage -22°F to 140°F (-30°C to +60°C)

Operator Specifications

	ZC2JE61	ZC2JE62	ZC2JE70	ZC2JE01	ZC2JE05
Differential Angle	—	5°	5°	2°	2°
Differential Travel at 90 PSI (6 bar)	.008" (0.2 mm)	—	—	—	—
Maximum Angle of Travel	—	—	—	75°	75°
Maximum Travel (B) at 90 PSIG (6 bar)	228" (5.8 mm)	—	—	—	—
Minimum Pre-Travel (A) at 90 PSIG (6 bar)	.059" (1.5 mm)	—	—	—	—
Minimum Operating Force at 90 PSI (6 bar)	3.6 lbf (16N)	—	—	—	—
Minimum Operating Torque at 90 PSI (6 bar)	7.1 oz in (50Nm)	35.4 oz in (250Nm)	35.4 oz in (250Nm)	35.4 oz in (250Nm)	—
Operating Angle (Minimum Lever Travel Including Pre-Travel Required For Operation)	—	23°	23°	12°	12°
Operating Diagram					

F

Switch Body With Plunger Heads

With ZC2JE61

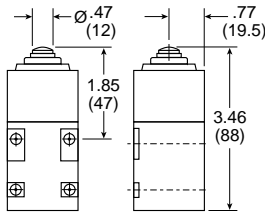

With ZC2JE62

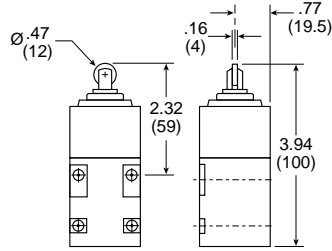

With ZC2JE70

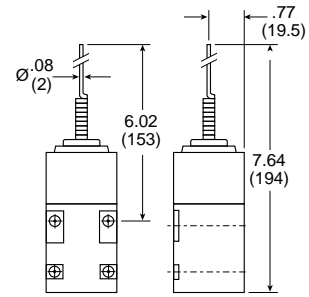

Switch Body With Rotary Heads and Operating Levers

With ZC2JY11

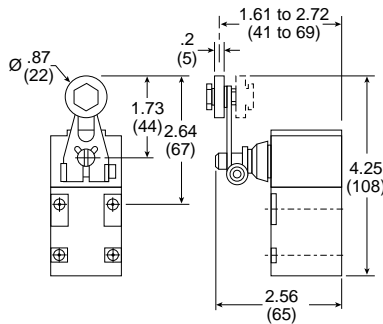

With ZC2JY31

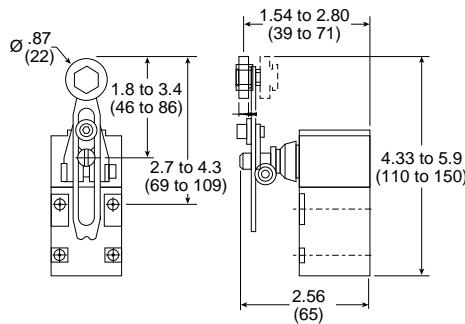

With ZC2JY51

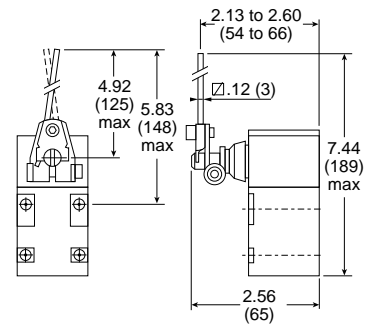

Rotary Heads With Operating Levers

ZC2JY81

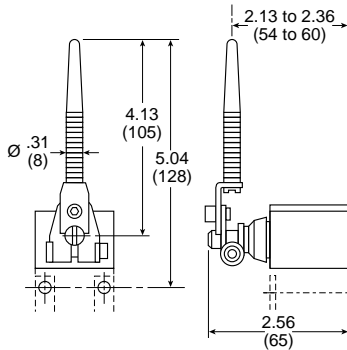

ZC2JY91

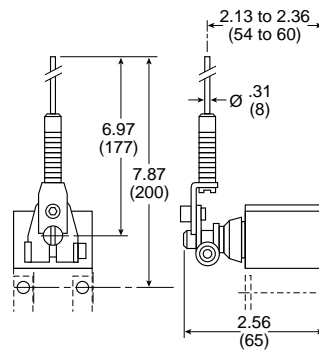

ZC2JY41

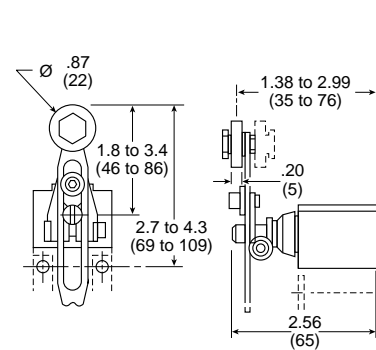

Pneumatic Switch Bodies

PXCJ117, PXCJ127

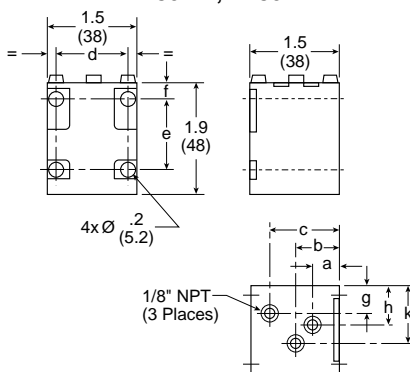

	inch	mm
a	.47	12
b	.75	19
c	1.16	29.5
d	1.14 to 1.18	29 to 30
e	1.18	30
f	.28	7
g	.43	11
h	.51	13
k	.94	24





Blocking Valves

The blocking valve is a single acting spring return 2/2 valve in a fitting format. The device requires a pneumatic pilot signal to open, which allows free flow of air, gas or liquid to pass. As long as a pilot signal is present, the device will remain open. When the pilot signal is removed, the internal spring will close the blocking valve, bubble tight. The blocking valve is oil serviceable and rated to 150 PSI.

These devices have two primary design uses: (1) to prevent unwanted gravity induced motion in cylinders during shut down procedures or during periods of lost supply pressure and (2) freezing the cylinder position by using a blocking valve at each end of the cylinder. Application needs such as tool or work piece protection, horizontal indexing or inspection stops are often satisfied by these devices.

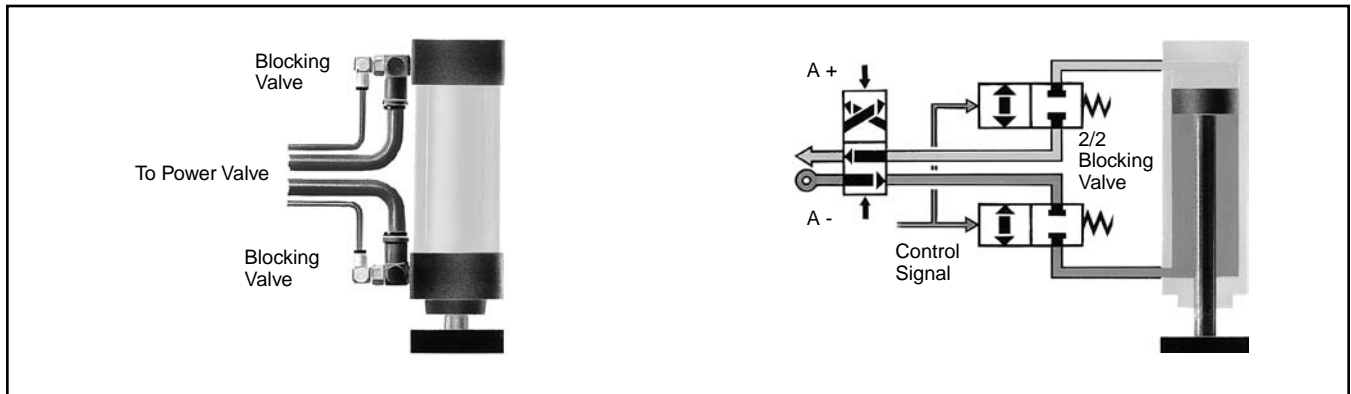
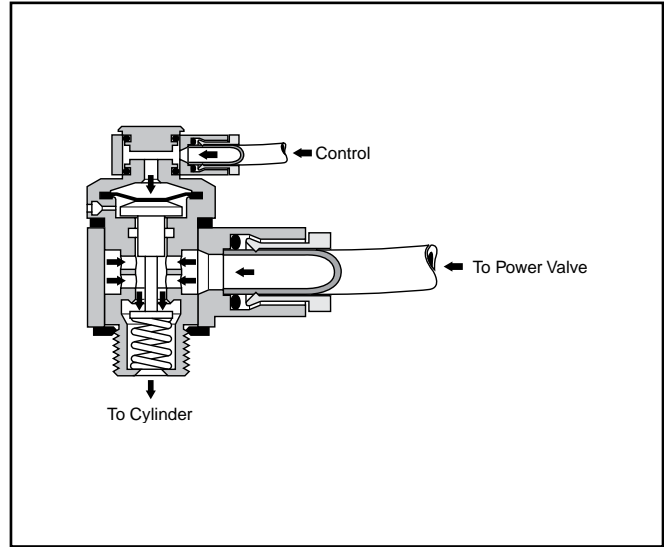

PWBA General Characteristics

Operating Pressure	0 to 150 PSI
Permissible Fluids	Air or neutral gas, 50 µm filtration, lubricated or not
Operating Temperature	5° to 140°F (-15° to 60°C)
Storage Temperature	-40° to 160°F (-40° to 70°C)
Flow	See page C15
Mechanical Life	10 Million
Maximum Operating Frequency	10Hz
Material: Body	Zinc alloy
Mounting Screw	Brass
Maximum Mounting Torque: 10-32 UNF and M5	88 inch pounds
1/8"	70 inch pounds
1/4"	105 inch pounds
3/8"	265 inch pounds
1/2"	310 inch pounds
Adjustment	N/A
Adjustment Locking	N/A

Piloting and De-Piloting Pressure

Blocking Valve Sizes	Pilot with Operating Pressure of:			
	30 PSI	60 PSI	90 PSI	120 PSI
1/8" BSP or NPT	33 PSI	40 PSI	45 PSI	50 PSI
1/4" BSP or NPT	33 PSI	40 PSI	45 PSI	50 PSI
3/8" BSP or NPT	35 PSI	40 PSI	45 PSI	50 PSI
1/2" BSP or NPT	45 PSI	50 PSI	55 PSI	60 PSI
Blocking Valve Sizes	Depilot with Operating Pressure of:			
	30 PSI	60 PSI	90 PSI	120 PSI
1/8" BSP or NPT	20 PSI	25 PSI	30 PSI	34 PSI
1/4" BSP or NPT	20 PSI	25 PSI	30 PSI	34 PSI
3/8" BSP or NPT	20 PSI	25 PSI	30 PSI	34 PSI
1/2" BSP or NPT	25 PSI	30 PSI	34 PSI	40 PSI

F





PWBA Series

For Cylinder Mounting (Can also be mounted in Threshold Sensor Banjo)
With Instant Tube Fittings



PWBA3469

Symbol	Connection for Pilot	BSP			NPT			
		Cylinder Port Thread (Male)	Connection for Tube	Catalog Number	Connection for Pilot	Cylinder Port Thread (Male)	Connection for Tube	Catalog Number
	4mm Tube	1/8"	6mm	PWBA1468	5/32" Tube	1/8"	1/4"	PWBA3468
		1/4"	6mm	PWBA1469		1/4"	1/4"	PWBA3469
		1/4"	8mm	PWBA1489				
		3/8"	8mm	PWBA1483				
		3/8"	10mm	PWBA1493				
		1/2"	12mm	PWBA1412				

With Threaded Connections and Tube Pilot Port



PWBA3833

Symbol	Connection for Pilot	BSP			NPT			
		Cylinder Port Thread (Male)	Connection from Valve (Female)	Catalog Number	Connection for Pilot	Cylinder Port Thread (Male)	Connection from Valve (Female)	Catalog Number
	4mm Tube	1/8"	1/4"	PWBA1898	5/32" * Tube	1/8"	1/8"	PWBA3888
		1/4"	1/4"	PWBA1899		1/4"	1/4"	PWBA3899
		3/8"	3/8"	PWBA1833	5/32" * Tube	3/8"	3/8"	PWBA3833
		1/2"	1/2"	PWBA1822		1/2"	1/2"	PWBA3822

* Instant fitting

PWBA14/34

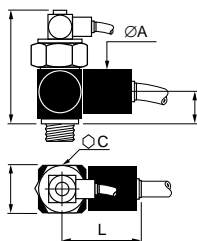

PWBA18/38

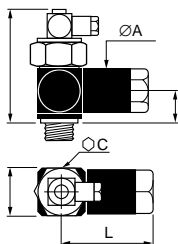

PWBA38

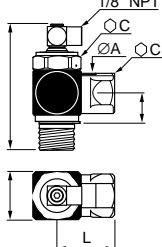

With Threaded Connections and Threaded Pilot Port

Connection for Pilot	NPT		
	Cylinder Port Thread (Male)	Connection from Valve	Catalog Number
1/8" pipe	1/8"	1/8"	PWBA38887
	1/4"	1/4"	PWBA38997
	3/8"	3/8"	PWBA38337
	1/2"	1/2"	PWBA38227

Dimensions: Inches (mm)

	Flow*	ØA	B	C	K	H	L
PWBA1468/3468	14.8	0.86" (22)	0.82" (21)	0.94" (24)	0.53" (13.5)	2.32" (59)	1.54" (39)
PWBA1469/3469 PWBA1489	19.4	0.86" (22)	0.82" (21)	0.94" (24)	0.53" (13.5)	2.09" (53)	1.54" (39)
PWBA1483 PWBA1493/3493	45.9	1.06" (27)	1.10" (28)	0.94" (24)	0.55" (14)	2.09" (53)	1.98" (50)
PWBA1412/3412	81.2	1.22" (31)	1.30" (33)	1.30" (33)	0.94" (24)	2.59" (66)	2.59" (66)
PWBA1898/3888	14.8	0.86" (22)	0.82" (21)	0.94" (24)	0.53" (13.5)	2.32" (59)	1.71" (43.5)
PWBA1899/3899	19.4	0.86" (22)	0.82" (21)	0.94" (24)	0.53" (13.5)	2.09" (53)	1.71" (43.5)
PWBA1833/3833	45.9	1.06" (27)	1.10" (28)	0.94" (24)	0.55" (14)	2.09" (53)	2.18" (55)
PWBA1822/3822	81.2	1.22" (31)	1.30" (33)	1.30" (33)	0.94" (24)	2.59" (66)	2.47" (63)
PWBA38887	14.8	0.75" (19)	0.87" (22)	0.83" (21)	0.67" (17)	2.20" (56)	1.73" (44)
PWBA38997	19.4	0.75" (19)	0.87" (22)	0.83" (21)	0.67" (17)	2.20" (56)	1.73" (44)
PWBA38337	45.9	1.06" (27)	1.18" (30)	1.06" (27)	0.91" (23)	2.64" (67)	1.42" (36)
PWBA38227	81.2	1.06" (27)	1.18" (30)	1.06" (27)	0.91" (23)	2.64" (67)	1.42" (36)

*SCFM at 90 PSI



General Description

Threshold Sensors – PWS

The plug-in threshold sensors provide feedback information on pneumatic cylinder status in one of three possible outputs . . . pneumatic, electric, or electronic. Mounted into the cylinder port, these devices monitor the back pressure of the cylinder's exhaust. When the cylinder's piston stops, the back pressure rapidly drops and the threshold sensor provides the desired output. Ideal for variable stroke applications such as robotics where other sensor type devices such as limit switches are impractical, these devices provide a signal whenever the cylinder stops motion.

The threshold sensor consists of two complementary sub assemblies (1) the banjo fitting and (2) the plug-in sensor element. In all cases, the sensor is easily plugged into the banjo fitting and locked in place with a spring clip. The banjo fitting is designed to accept (piggy backed) other functional fittings such as flow controls or blocking valves. Simply select the sensor based on the type feedback signal that best fits the application.

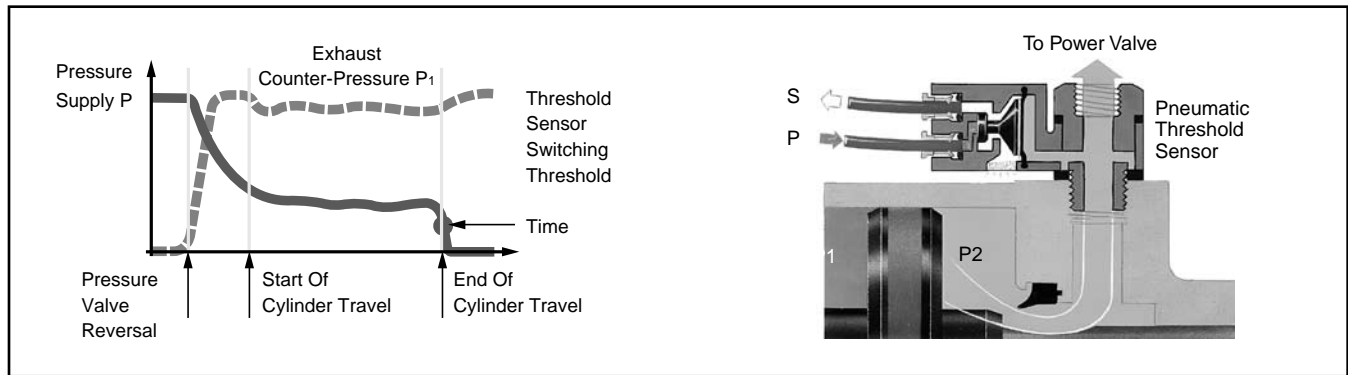
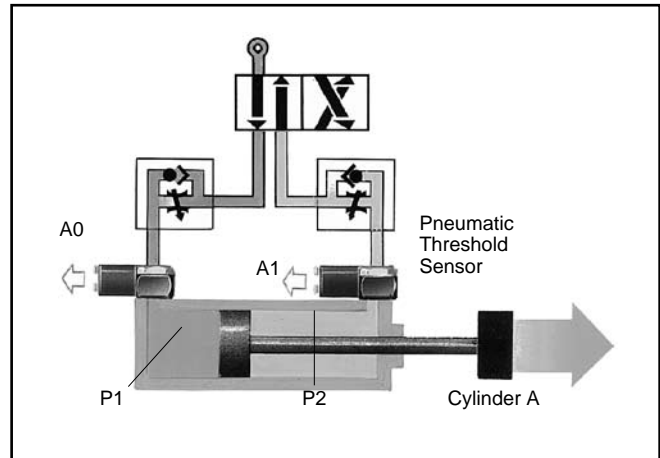

PWS General Characteristics

Operating Pressure	0 to 150 PSI
Permissible Fluids	Air or neutral gas, 50 µm filtration, lubricated or not
Operating Temperature	5° to 140°F (-15° to 60°C)
Storage Temperature	-40° to 160°F (-40° to 70°C)
Flow	N/A
Mechanical Life	10 Million
Maximum Operating Frequency	10Hz
Material: Body	Thermoplastic
Mounting Screw	Brass
Maximum Mounting Torque: 10-32 UNF and M5	88 inch pounds
1/8"	70 inch pounds
1/4"	105 inch pounds
3/8"	265 inch pounds
1/2"	310 inch pounds
Adjustment	N/A
Adjustment Locking	N/A

Piloting and De-Piloting Pressure

Threshold Sensors	Pilot with Operating Pressure of 90 PSI	Depilot with Operating Pressure of 90 PSI
PWSP111	64 PSI	6 PSI
PWSM1012	15 PSI	9 PSI
PWSE101 and PWSE111	10 PSI	7 PSI

F



Threshold Sensors

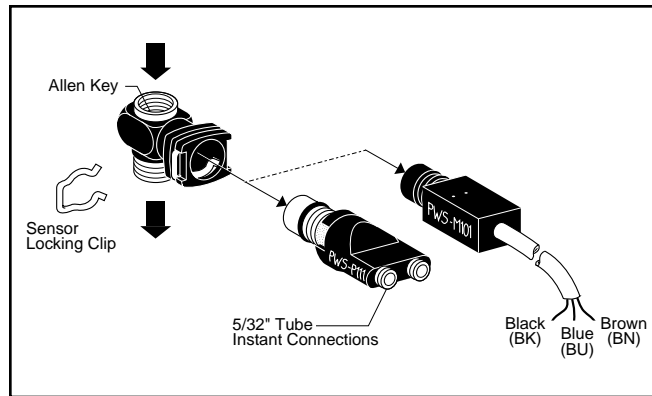

Model Selection

Banjo Sockets (with Sensor Clip)		
Port Size	Model Number	Wrench
10-32	PWSB1557	5/16" Hex
1/8"	PWSB1887	3/16" Allen
1/4"	PWSB1997	5/16" Allen
3/8"	PWSB1337	3/8" Allen
1/2"	PWSB1227	1/2" Allen

Plug-in Sensors		
Output	Model Number	Connection
Pneumatic	PWSP111	5/32" push-in
Electrical	PWSM1012	3-wire cable (6 ft)

Mounting

Banjo fittings in 10-32 to 1/2" pipe sizes are designed to be installed directly into actuator ports (up to 5" bore cylinders). The banjo fitting can accommodate other functional fittings and components such as right angle flow control valves or blocking valves. Banjo fittings screw into actuators using an Allen wrench or 5/16" hex head wrench for 10-32 size. Electrical or pneumatic feedback element snaps into place using a locking clip.

Operation

Pneumatic sensors have a continuous pressure signal applied to the sensor device. Electrical sensors have a continuous electrical signal applied to the sensor device. The threshold sensor assembly mounted directly into the cylinder Port provides an output signal S, which can be pneumatic or electrical, when the falling back pressure in the exhausting chamber of the cylinder reaches the operating threshold (approximately 6-9 PSIG). (The device is a normally passing device. The output is only on when there is nearly zero pressure at the cylinder.)

Application

The threshold sensor provides electrical or pneumatic feedback information on pneumatic (air) cylinder status. These devices monitor the back pressure of the cylinder's exhausting chamber. When the cylinder stops, the back pressure drops and the threshold sensor provides the desired output. Ideal for variable stroke applications. The banjo fitting and the feedback element are two separate subassemblies, giving the user flexibility between electrical and pneumatic outputs as feedback.

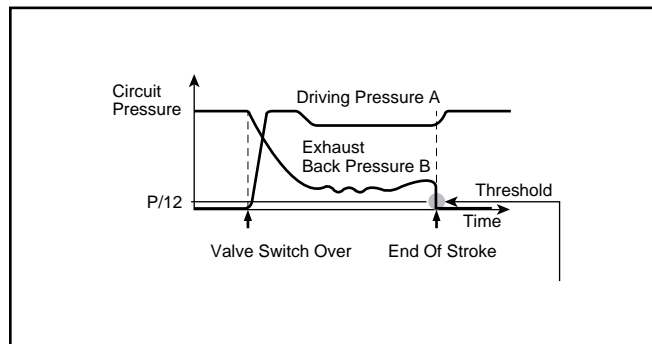

Dimensions

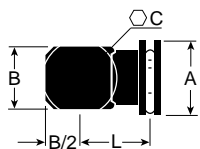
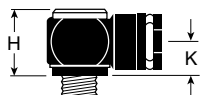

Banjo Socket

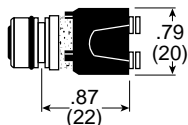

PWSB111

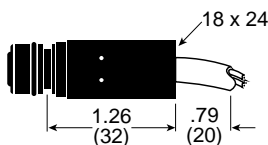

PWSM1012

Model	A	B	C	H	K	L
PWSB1557	.98 (25)	.43 (11)	5/16" Hex	.79 (20)	.40 (10)	.67 (17)
PWSB1887	.98" (25)	.63 (16)	3/16" Allen	.71 (18)	.40 (10)	.79 (20)
PWSB1997	.98 (25)	.83 (21)	5/16" Allen	.71 (18)	.40 (10)	.87 (22)
PWSB1337	.98 (25)	1.10 (28)	3/8" Allen	.79 (20)	.47 (12)	.98 (25)
PWSB1227	.98 (25)	1.30 (33)	1/2" Allen	.93 (24)	.55 (14)	1.02 (26)

inches
(mm)

Specifications

Operating Pressure 0 to 150 PSIG (0 to 10 bar)

Temperature Range 5°F to 140°F (-15°C to 60°C)

CAUTION: If it is possible that the ambient temperature may fall below freezing, the medium must be moisture free to prevent internal damage or unpredictable behavior.

Maximum Operating Frequency 10 Hz

Pilot Pressure (PWSP111) >64 PSIG (4.4 bar)

Threshold Pressure 6 to 9 PSIG (.4 to .6 bar)

Output Flow Rate (PWSP111) 3 SCFM at 90 PSIG

Current Rating (PWSM1012) –

5 VA, 250 VAC

5W, 48 VAC

Materials –

Body Thermoplastic

Mounting Screw & Threads Brass

Life Expectancy –

10 million cycles with dry air at 90 PSIG, 68°F, and 1 Hz operating frequency

Voltage Range (PWSM1012) –

12 - 240 VAC

12 - 48 VDC

F

Universal Description	Electrical		Fluid Power	
	Function	Symbol	Function	Symbol
Normally Non-Passing (NNP)	Normally Open (N.O.)		Normally Closed (N.C.)	<div style="display: flex; justify-content: space-around;"> <div style="text-align: center;"> <p>2-Way</p> </div> <div style="text-align: center;"> <p>3-Way</p> </div> </div>
Normally Passing (NP)	Normally Closed (N.C.)		Normally Open (N.O.)	<div style="display: flex; justify-content: space-around;"> <div style="text-align: center;"> </div> <div style="text-align: center;"> </div> </div>





“LV” & “EZ” Series

Lockout Valves, 3-Way, 3-Port, 2-Position

Section F



“LV” Series		“EZ” Series	
Basic Features	F70	Basic Features	F72
Applications	F70	Applications	F72
Mounting	F70	Mounting	F72
Dimensions	F70	Dimensions	F72
“LV” Series Technical Information		“EZ” Series Technical Information	
Operation	F71	Operation	F73
Specifications	F71	Specifications	F73
Ordering Information	F71	Ordering Information	F73
		Flow & Safety Standards	F74

Bold Items are Most Popular.





Basic Features

“LV” Series

Features

- Used in systems for compliance with OSHA Standard 29 CFR Part 1910
- 3/8 inch to 1-1/4 inch Pipe Sizes
- Cv’s from 6.0 to 14
- 3/4 and 1-1/4 inch Exhaust Ports available
- Rugged Cast Aluminum Alloy Body
- Inline or Surface Mountable
- Safety Yellow and Red for High Visibility
- Detented Spool
- Exhaust Port Threaded for Installation of Silencer or Line for Remote Exhausting

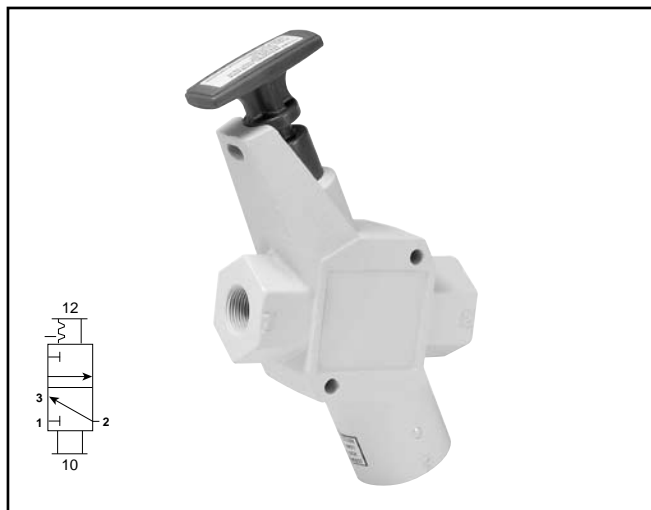

Applications

Lockout valves are installed in pneumatic drop legs, or individual pneumatic control lines (see Figure 1). In accordance with OSHA procedures, lockout valves are used during maintenance and service procedures of pneumatically (air) operated equipment. Prior to servicing, the red handle is pressed inward, blocking pressure and relieving all downstream air pressure. A padlock is installed through the locking hasp, Preventing accidental actuation during the maintenance procedure. Following maintenance, the padlock is removed and the red handle is pulled outward, returning air pressure to the system. (For complete Lockout / Tagout procedures, consult OSHA Standard 29 CFR Part 1910 in U.S. Federal Register/Vol. 54 No. 169, Friday, September 1, 1989 / Page 36644.)

Dimensions

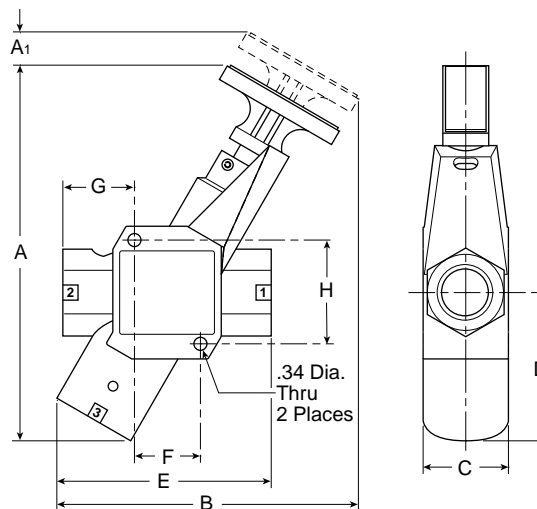

LV Series, 3/4" Exhaust Port Inches (mm)

A	A1	B	C	D
8.32 (211)	0.64 (16)	6.60 (168)	2.00 (51)	3.06 (78)
E	F	G	H	
4.24 (108)	1.32 (111)	1.56 (40)	2.21 (56)	

LV Series, 1-1/4" Exhaust Port Inches (mm)

A	A1	B	C	D
9.91 (252)	0.85 (22)	7.95 (202)	2.25 (57)	3.91 (99)
E	F	G	H	
5.65 (144)	1.74 (44)	1.89 (48)	2.74 (70)	

Mounting

Valves can be inline mounted or surface mounted using the two 11/32" mounting holes provided in the valve body. Mount valves in plain view with the handle oriented for accessibility.





Operation

Normal Machine Operation – Valve Open

With the handle pulled outward. Inlet Port 1 is open to outlet Port 2. Exhaust Port 3 is blocked.

Lockout Operation – Valve Closed

With the handle pushed inward. Inlet Port 1 is blocked. Outlet Port 2 is open to Exhaust Port 3.

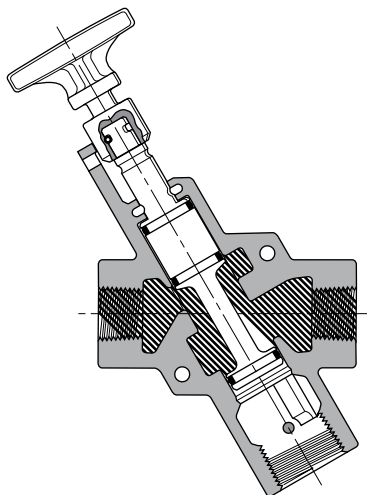

Open

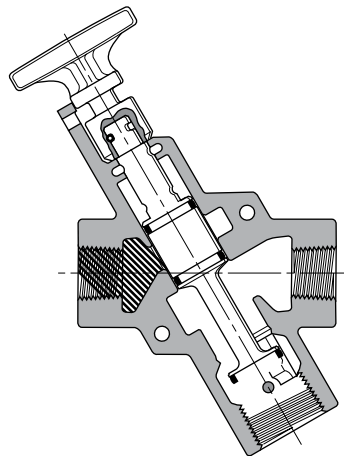

Closed

Specifications

Operating Pressure Range:

0 to 250 PSIG (0 to 1725 kPa)

Operating Temperature Range (Ambient):

32°F to 160°F (0°C to 71°C)

Lubrication:

For best results and service life, use clean, moisture free, lubricated air.

Recommended Lubricant:

F442 Oil

Materials of Construction

Body..... Cast Aluminum Alloy

Handle..... 3/4" Exhaust Port - Cast Aluminum Alloy
1-1/4" Exhaust Port - Plastic

Spool.....Aluminum

Seals Carboxylated Nitrile

Detent SpringStainless Steel

GreaseMagnalube G[†]

LV Series Model Number Index

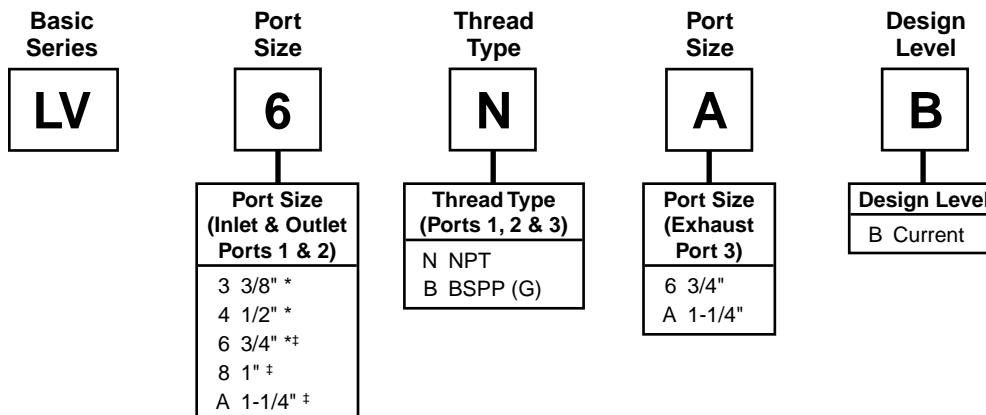

* Available with 3/4" Exhaust Port.

‡ Available with 1-1/4" Exhaust Port.

† Trademark Magnalube



Basic Features

“EZ” Series

Features

- Combines Lockout and Soft-Start Functions in a Single Unit
- Used in systems for compliance with OSHA Standard 29 CFR Part 1910
- 3/8 inch to 1-1/4 inch Pipe Sizes
- Cv’s from 3.7 to 13.7
- 3/4 and 1-1/4 inch: Exhaust Ports available
- Rugged Cast Aluminum Alloy Body
- Exhaust Port Threaded for Installation of Silencer or Line for Remote Exhausting
- Inline or Surface Mountable

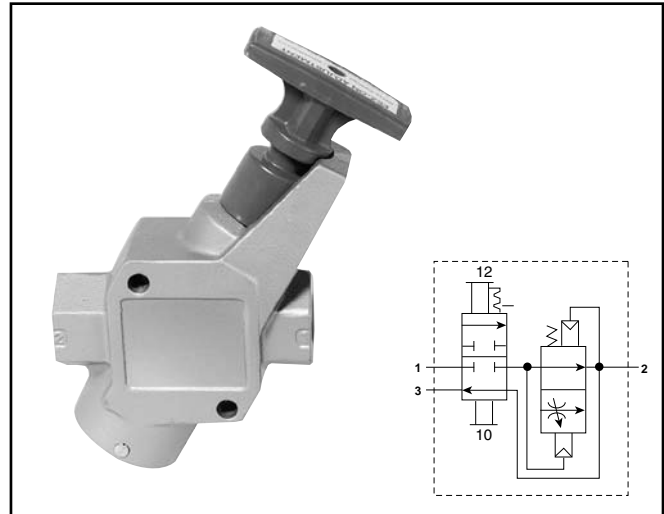

Applications

EZ valves are installed in pneumatic drop legs, or individual pneumatic control lines (see Figure 1). In accordance with OSHA procedures, EZ valves are used during maintenance and service procedures of pneumatically (air) operated equipment. Prior to servicing, the blue handle is pressed inward, blocking pressure and relieving all downstream air pressure. A padlock is installed through the locking hasp, preventing accidental actuation during the maintenance procedure. Following maintenance, the padlock is removed and the blue handle is pulled outward, gradually returning air pressure to the system. (For complete Lockout / Tagout procedures, consult OSHA Standard 29 CFR Part 1910 in U.S. Federal Register/Vol. 54 No. 169, Friday, September 1, 1989 / Page 36644.)

Dimensions

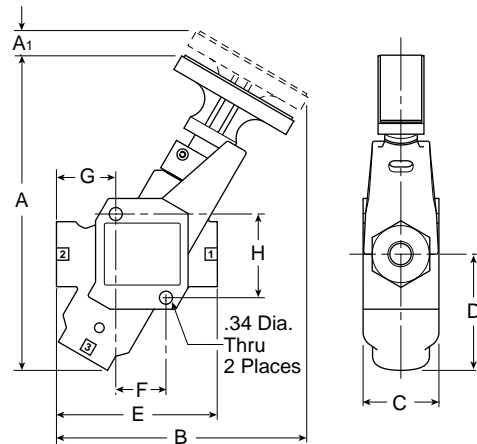

EZ Series, 3/4" Exhaust Port Inches (mm)

A 8.32 (211)	A1 0.64 (16)	B 6.60 (168)	C 2.00 (51)	D 3.06 (78)
E 4.24 (108)	F 1.32 (111)	G 1.56 (40)	H 2.21 (56)	

EZ Series, 1-1/4" Exhaust Port Inches (mm)

A 9.91 (252)	A1 0.85 (22)	B 7.95 (202)	C 2.25 (57)	D 3.91 (99)
E 5.65 (144)	F 1.74 (44)	G 1.89 (48)	H 2.74 (70)	

Mounting

Valves can be inline mounted or surface mounted using the two 11/32" mounting holes provided in the valve body. Mount valves in plain view with the handle oriented for accessibility.

F



Operation

Normal Machine Operation – Valve Open

When the blue handle is pulled outward, the adjustable needle valve (accessed through the top of the handle) setting determines the rate of pressure buildup. When downstream pressure reaches the full flow described in the specifications below, Inlet Port 1 is open to outlet Port 2. Exhaust Port 3 is blocked.

Lockout Operation – Valve Closed

When the blue handle is pushed inward, the Inlet Port 1 is blocked. Downstream air is exhausted through Exhaust Port 3.

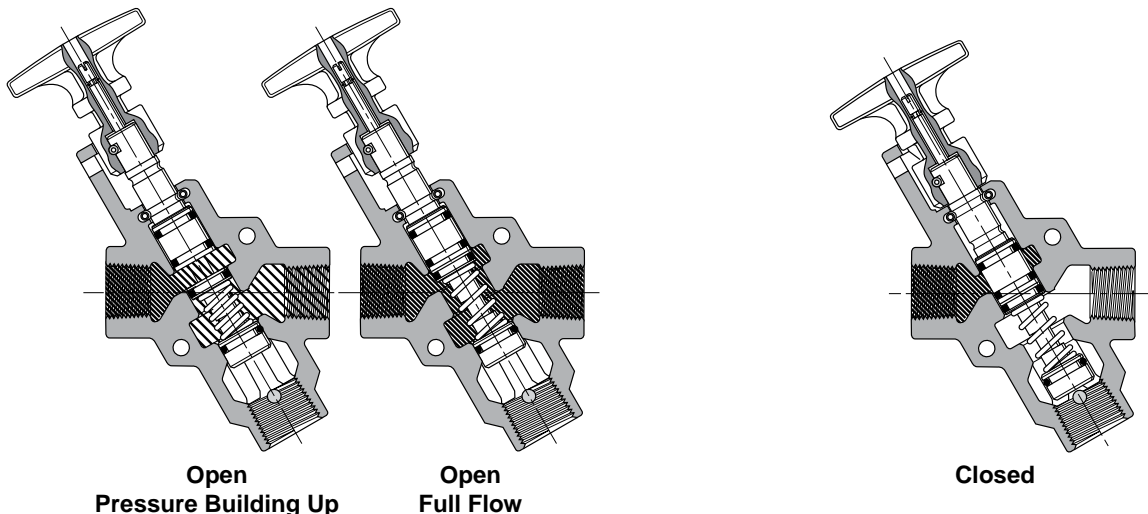

Specifications

Operating Pressure Range:

30 to 150 PSIG (2 to 10 bar)
Open to Full Flow: Inlet Pressure - 25 PSIG (1.7 bar)

Operating Temperature Range (Ambient):

40°F to 175°F (4°C to 80°C)

Lubrication:

For best results and service life, use clean, moisture free, lubricated air.

Recommended Lubricant:

F442 Oil

Materials of Construction

- Body..... Cast Aluminum Alloy
- Handle..... Plastic
- Spool..... Aluminum
- Seals Carboxylated Nitrile
- Detent Spring Stainless Steel
- Grease Magnalube G[†]

EZ Combination EEZ-On Series Model Number Index

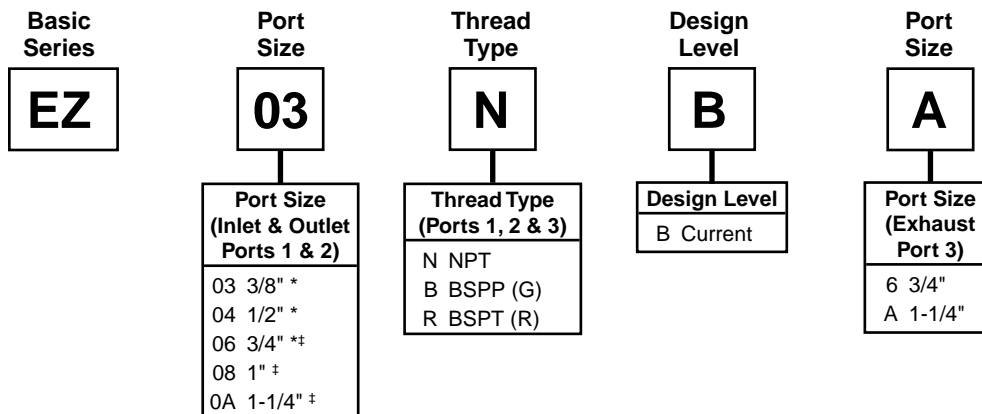

Notes:

* Available with 3/4" Exhaust Port.

† Available with 1-1/4" Exhaust Port.

† Trademark Magnalube



Flow

Model	1 to 2 Cv	2 to 3 Cv
LV3N6B	6.00	8.00
LV4N6B	7.10	8.30
LV6N6B	8.60	9.50
LV6NAB 	13.00	12.00
LV8NAB	13.00	14.00
LVANAB	20.00	14.00

Model	1 to 2 Cv	2 to 3 Cv
EZ03NB6	3.79	3.78
EZ04NB6	5.31	3.77
EZ06NBA	6.01	9.25
EZ08NBA	11.18	8.13
EZ0ANBA	13.74	8.03

Schematic

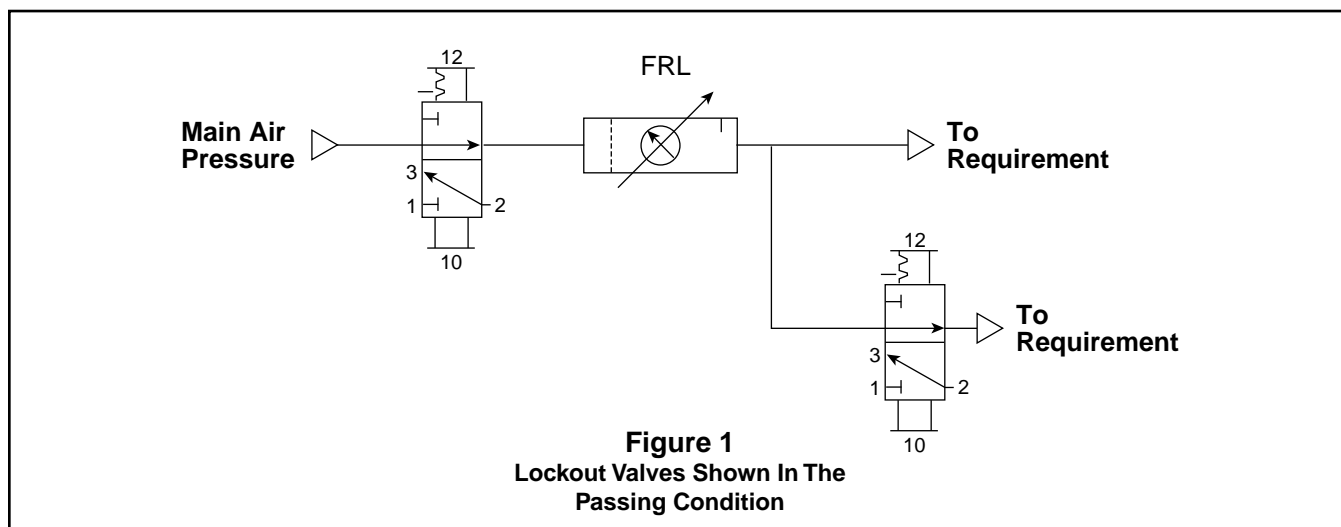

Friday, September 1, 1989 the Occupational Safety and Health Administration (OSHA) passed a standard, 29CFR Part 1910, requiring certain lockout and / or tagout procedures for the control of a hazardous energy source. This standard addresses practices and procedures that are necessary to disable the release of potentially hazardous energy while maintenance and servicing activities are being performed. Tagout refers to the use of tags to warn workers when equipment using potentially hazardous energy is being serviced. Lockout is the procedure which ensures that all power to a piece of equipment is isolated, locked or blocked and dissipated using a method that cannot be readily removed to bypassed. Dissipation means stored energy at the equipment is brought to a neutral state. This standard is expected to save 120 lives and prevent 60,000 accidents a year. This OSHA Standard became effective October 31, 1989.

A typical application (Figure 1) shows a main lockout valve mounted in the main drop leg, before the split to machine functions. Additional lockout valves can be used to isolate individual control lines. Before servicing, the valve can be actuated and locked to isolate downstream from pressure, and exhaust downstream to atmosphere thus making equipment safe for maintenance.

To reference this standard see the U.S. Federal Register / Vol. 54, No. 169 / Friday, September 1, 1989 / Page 36644. For copies of this standard, contact U.S. Department of Labor, Occupational Safety and Health Administration, Office of Publication, Room N3101, Washington, DC 20210, (202) 523-9667.

F



Ball Valves

1/4" to 2", 2-Way

1/4" to 1", 2-Way Vented

Plug Valves

1/8" to 1/4" Pipe Size

Section F



Ball Valve Series 500

Basic Features F76

Part Numbers & Dimensions F77-F78

Ball Valve Series 520

Basic Features F80

Part Numbers & Dimensions F81

Ball Valve Series 708 / 709

Basic Features F82

Part Numbers & Dimensions F83

Ball Valve Series 200 / 608 / 609

Basic Features F84

Part Numbers & Dimensions F85

Plug Valve / Drain Cock

Basic Features F86

Part Numbers & Dimensions F87-F88



Basic Features & Specifications

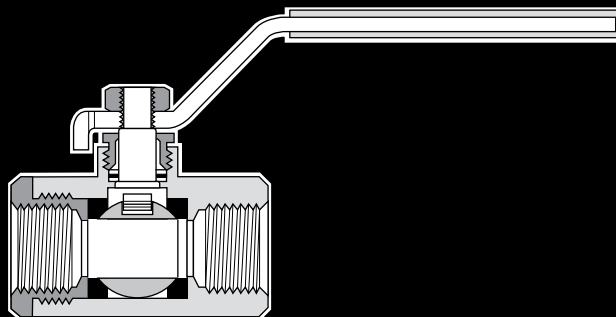

Brass Ball Valves Series 500

Advantages

Parker's forged body ball valve provides extended service life and resists failure caused by severe temperature applications. Optimum flow design assures maximum system efficiency. Highly inert PTFE seats and seals provide resistance to chemical corrosion. Parker also provides a blow-out proof stem, chrome plated brass ball and a specially designed handle enabling increased turning leverage for ease of opening and closing. Parker's ball valve can be readily identified assuring high quality engineering and reliability. This economical ball valve is available in female pipe sizes. Parker's ball valve bodies are machined from high quality CA 377 forgings.

Applications

Parker's industrial ball valve product line is intended for general purpose use. Please be aware that ball valves are intended for use in the fully open or closed positions. Depending on application conditions, throttling of the valve may result in premature seal failure and/or inability to turn the valve handle.

For use as fuel line shutoffs for gasoline and diesel powered over the highway, off highway, and construction equipment vehicles. Water and air service lines on capital equipment and plant design plumbing that require total shutoff capability.

Working Pressure and Temperature

Saturated steam service up to 150 PSI and 400°F
Vacuum, 29 Inches of Mercury
Vented up to 250 PSI

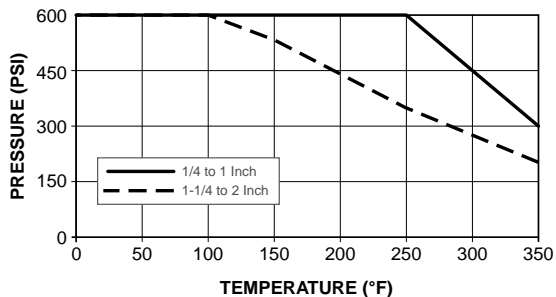

Style	Type	Material	Size	Options
V	500	P	4	00
Style	V – Valve			
	VP – Valve, Padlocking Handle			
	VV – Valve, Vented			
	VVP – Valve, Vented, Padlocking Handle			
Type	500 – Female / Female PTF Ports			
Material	P – Brass			
	PN – Nickle Plated			
Size	4 - 1/4"			
	6 - 3/8"			
	8 - 1/2"			
	12 - 3/4"			
	16 - 1"			
Options	04 - Tee Handle			

Style	Type	Material	Size
V	500	P	20
Style	V – Valve		
	VP – Valve, Padlocking Handle		
Type	500 – Female / Female PTF Ports		
Material	P – Brass		
Size	20 – 1-1/4"		
	24 – 1-1/2"		
	32 – 2"		

Flow Data

Valve Size	Cv
1/4	4.0
3/8	5.8
1/2	12.0
3/4	35.0
1	54.0
1-1/4	57.0
1-1/2	92.0
2	224.0

Operating Instructions

Quarter turn is "ON" or "OFF".
(Provides positive stop action for full shutoff.)

NOTE: PERIODICALLY CHECK THE ADJUSTABLE PACKING NUT AND TIGHTEN AS REQUIRED.



V500P Female-Female Pipe Ends

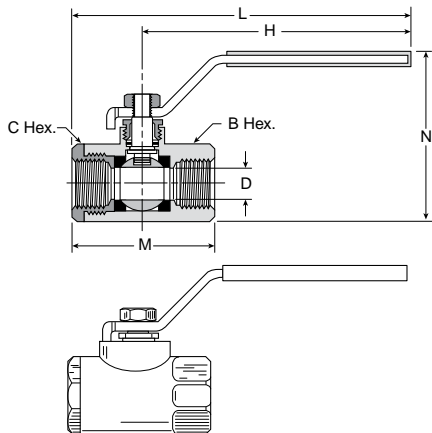

Part No.	Pipe Thread [PTF]	B Hex.	C Hex.	H	L	M	N	Flow Dia. D
V500P-4	1/4	15/16	15/16	3.96	4.90	2.03	2.47	0.375
V500P-6	3/8	15/16	15/16	3.96	4.90	2.03	2.47	0.375
V500P-8	1/2*	1-1/16	1-1/16	3.96	5.00	2.20	2.58	0.500
V500P-12†	3/4**	1-1/4	1-5/16	3.96	5.25	2.42	2.81	0.685
V500P-16†	1**	1-1/2	1-9/16	3.96	5.34	2.75	3.08	0.875

*PTF special short
**PTF special extra short
† Available in Full Flow Panel Mount, see XV508P Series

V500P-X-04 Tee Handle, Female Pipe Ends

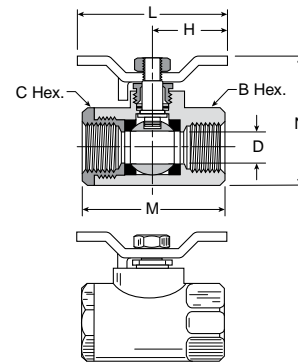

Part No.	Pipe Thread	B Hex.	C Hex.	H	L	M	N	Flow Dia. D
V500P-4-04	1/4	15/16	15/16	1.25	2.50	2.03	1.87	.375
V500P-6-04	3/8	15/16	15/16	1.25	2.50	2.03	1.87	.375
V500P-8-04	1/2*	1-1/16	1-1/16	1.25	2.50	2.20	1.98	.500
V500P-12-04	3/4**	1-1/4	1-5/16	1.25	2.50	2.42	2.20	.685
V500P-16-04	1**	1-1/2	1-9/16	1.25	2.50	2.75	2.48	.875

V500P-20, V500P-24, V500P-32
Female - Female Pipe Ends

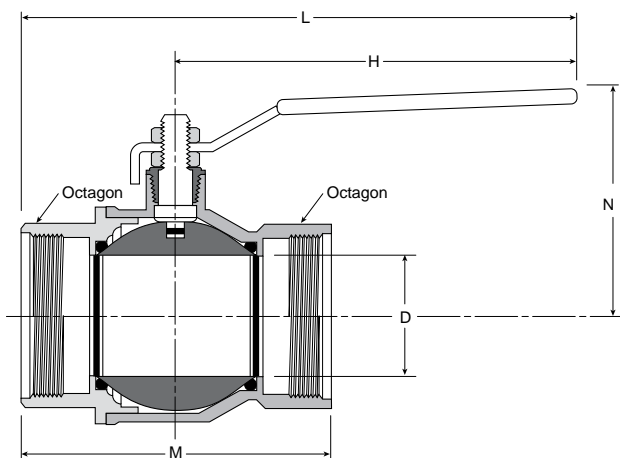

Part No.	Pipe Thread [PTF]	Octagon	H	L	M	N	Dia. D
V500P-20	1-1/4	1.93	6.22	8.05	3.66	3.01	1.18
V500P-24	1-1/2	2.13	6.22	8.23	4.02	3.25	1.50
V500P-32	2	2.69	6.22	8.58	4.76	3.52	1.89

V500P-X-21 Oval Handle, Female Pipe Ends

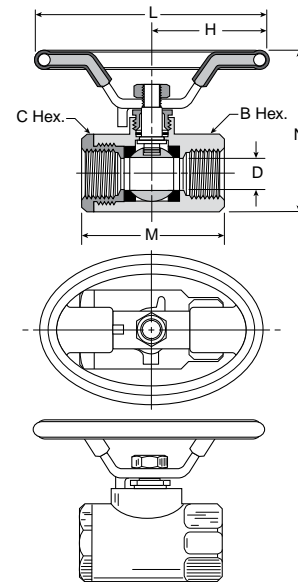

Part No.	Pipe Thread	B Hex.	C Hex.	H	L	M	N	Flow Dia. D
V500P-4-21	1/4	15/16	15/16	1.74	3.49	2.03	2.38	.375
V500P-6-21	3/8	15/16	15/16	1.74	3.49	2.03	2.38	.375
V500P-8-21	1/2*	1-1/16	1-1/16	1.74	3.49	2.20	2.49	.500
V500P-12-21	3/4**	1-1/4	1-5/16	1.74	3.48	2.42	2.71	.685
V500P-16-21	1**	1-1/2	1-9/16	1.74	3.48	2.75	2.99	.875



VP500P Locking Handle, Female Pipe Ends

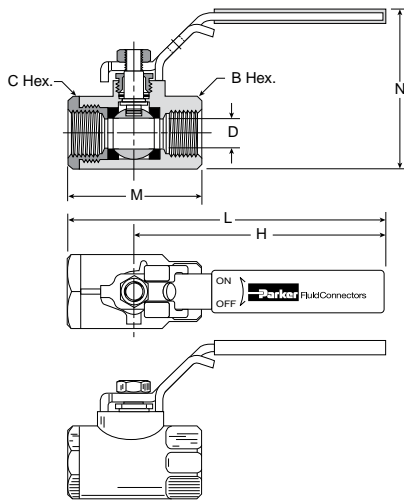

Part No.	Pipe Thread	B Hex.	C Hex.	H	L	M	N	Flow Dia. D
VP500P-4	1/4	15/16	15/16	3.96	4.90	2.03	2.47	0.375
VP500P-6	3/8	15/16	15/16	3.96	4.90	2.03	2.47	0.375
VP500P-8	1/2*	1-1/16	1-1/16	3.96	5.00	2.20	2.58	0.500
VP500P-12	3/4**	1-1/4	1-5/16	3.96	5.25	2.42	2.81	0.685
VP500P-16	1**	1-1/2	1-9/16	3.96	5.34	2.75	3.08	0.875
For use with 5/16" Dia. shank lock; 0.33 Dia.								
VP500P-20	1-1/4	1-15/16	1-15/16	6.22	8.05	3.66	4.04	1.180
VP500P-24	1-1/2	2-1/8	2-1/8	6.22	8.23	4.02	4.52	1.500
VP500P-32	2	2-11/16	2-11/16	6.22	8.60	4.76	5.07	1.890
For use with 9/32" Dia. shank lock; 0.31 Dia.								
*PTF special short								
**PTF special extra short								

VVP500P OSHA 29 CFR Part 1910 Vented, Locking Handle, Female Pipe Ends

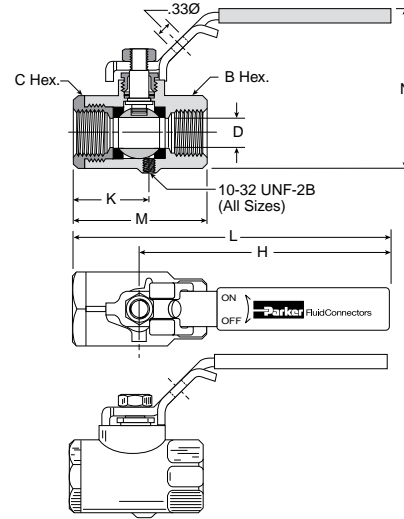

Part No.	Pipe Thread	B Hex.	C Hex.	K	H	L	M	N	Flow Dia. D
VVP500P-4	1/4	15/16	15/16	1.11	3.96	4.90	2.03	2.47	0.375
VVP500P-6	3/8	15/16	15/16	1.11	3.96	4.90	2.03	2.47	0.375
VVP500P-8	1/2*	1-1/16	1-1/16	1.23	3.96	5.00	2.20	2.58	0.500
VVP500P-12	3/4**	1-1/4	1-5/16	1.45	3.96	5.25	2.42	2.81	0.685
VVP500P-16	1**	1-1/2	1-9/16	1.58	3.96	5.34	2.75	3.08	0.875
For use with 5/16" Dia. shank lock									
*PTF special short									
**PTF special extra short									

VV500P Vented, Female Pipe Ends

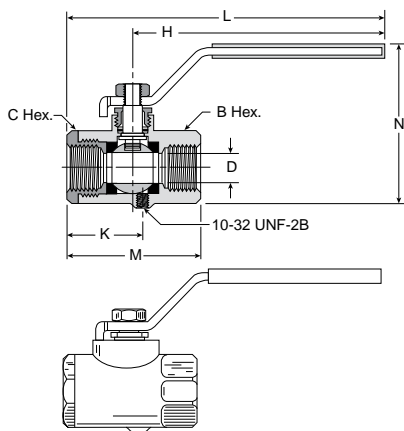

Part No.	Pipe Thread [PTF]	B Hex.	C Hex.	K	H	L	M	N	Flow Dia. D
VV500P-4	1/4	15/16	15/16	1.11	3.96	4.90	2.03	2.47	0.375
VV500P-6	3/8	15/16	15/16	1.11	3.96	4.90	2.03	2.47	0.375
VV500P-8	1/2*	1-1/16	1-1/16	1.23	3.96	5.00	2.20	2.58	0.500
VV500P-12	3/4**	1-1/4	1-5/16	1.45	3.96	5.25	2.42	2.81	0.685
VV500P-16	1**	1-1/2	1-9/16	1.58	3.96	5.34	2.75	3.08	0.875
*PTF special short									
**PTF special extra short									

F



Basic Features & Specifications

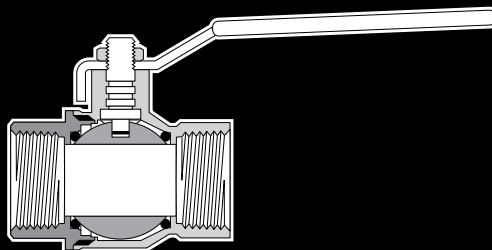

Brass Ball Valves Series 520

Advantages

Parker's forged body ball valve provides extended service life and resists failure caused by severe temperature applications. Full flow design assures maximum system efficiency. Highly inert PTFE seats provide resistance to chemical corrosion. Two Viton o-rings at the stem provide maximum safety with no maintenance. The blow-out proof stem, chrome plated brass ball and a specially designed handle enable increased turning leverage for ease of opening and closing. Parker's ball valve can be readily identified, assuring high quality engineering and reliability. This economical ball valve is available in female pipe sizes.

Applications

Parker's industrial ball valve product line is intended for general purpose use. Please be aware that ball valves are intended for use in the fully open or closed positions. Depending on application conditions, throttling of the valve may result in premature seal failure and/or inability to turn the valve handle.

For use as shutoffs for highway, off highway, and construction equipment vehicles. Water and air service lines on capital equipment and plant design plumbing that require total shutoff capability.

Working Pressure and Temperature

Saturated steam service up to 150 PSI and 350° F
Vacuum, 29 Inches of Mercury

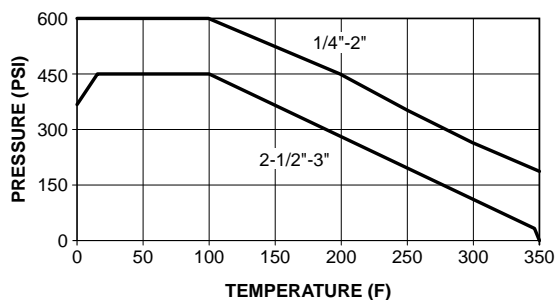

Style	Type	Material	Size	Options
V	520	P	4	00
Style	V – Valve			
Type	520 – Female / Female PTF Ports			
Material	P – Brass			
Size	4 - 1/4"			
	6 - 3/8"			
	8 - 1/2"			
	12 - 3/4"			
	16 - 1"			
	20 - 1-1/4"			
	24 - 1-1/2"			
32 - 2"				

Operating Instructions

Quarter turn is "ON" or "OFF".
(Provides positive stop action for full shutoff.)

U.L. Listed

U.L. Category	Description
YSDT	LP-Gas Shut-off Valves
YRBX	Flammable Liquid Shut-off Valves
YRPV	Gas Shut-off Valves
YQNZ	Compressed Gas Shut-off Valves



V520P Brass Ball Valve

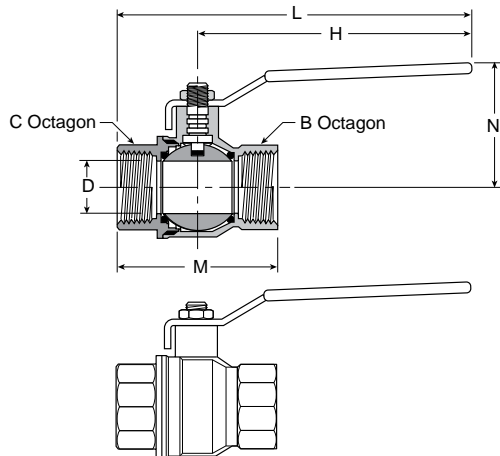

Part No.	Pipe Thread	B Octagon	C Octagon	H	L	M	N	Flow Dia. D
V520P-4	1/4-18	.79	.79	3.94	4.83	1.77	1.50	.310
V520P-6	3/8-18	.79	.79	3.94	4.83	1.77	1.50	.400
V520P-8	1/2-14	.98	.98	3.94	5.10	2.32	1.69	.600
V520P-12	3/4-14	1.22	1.22	4.72	5.98	2.52	1.97	.790
V520P-16	1-11.5	1.57	1.57	4.72	6.32	3.19	2.13	1.000
V520P-20	1-1/4	1.93	1.93	6.22	8.05	3.66	2.82	1.250
V520P-24	1-1/2	2.13	2.13	6.22	8.23	4.02	3.06	1.570
V520P-32	2	2.69	2.69	6.22	8.58	4.76	3.33	2.000
V520P-40	2-1/2	3.35	3.35	10.04	13.11	6.14	5.20	2.520
V520P-48	3	3.89	3.89	10.04	13.52	6.97	5.51	3.000



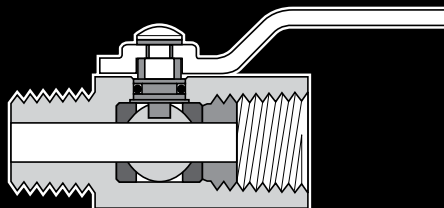

Micro Ball Valve Series 708 / 709

Advantages

The Parker Micro-Valve is designed to be used in confined and hard to reach applications. This miniature 2 way valve has a barstock body for extended service life and is offered with either male / female or female / female pipe ends. Features of the MV708 / 709 valves include chrome plate ball, PTFE seats, nitrile stem seal and a low profile chrome plated steel handle.

Applications

Parker's industrial ball valve product line is intended for general purpose use. Please be aware that ball valves are intended for use in the fully open or closed positions. Depending on application conditions, throttling of the valve may result in premature seal failure and / or inability to turn the valve handle.

Working Pressure and Temperatures

These valves are designed and built for use at pressures and temperatures within the stated ranges. Consult the factory for any use outside of these ranges.

Vacuum to 29 inches Hg

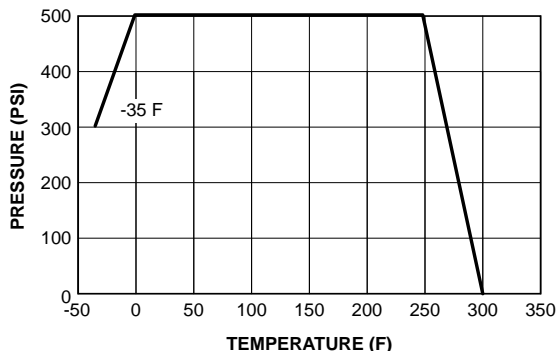

Style	Type	Size
MV	708	4
	709	
Style	MV – Mini Valve	
Type	708 – Male / Female	
	709 – Female / Female	
Size	4 - 1/4"	

Flow Data

Valve Size	MV708 Cv	MV709 Cv
1/4	.95	.95

Operating Instructions

Quarter turn is "ON" or "OFF".
(Provides positive stop action for full shutoff.)



**MV708 Male-Female Pipe Ends,
Mini Ball Valve**

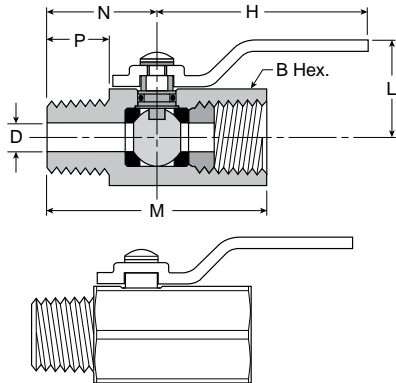

Part No.	Pipe Thread	B Hex.	H	L	M	N	P	Flow Dia. D
MV708-4	1/4	11/16	1.52	.70	1.57	.79	.50	.210

**MV709 Female Pipe Ends,
Mini Ball Valve**

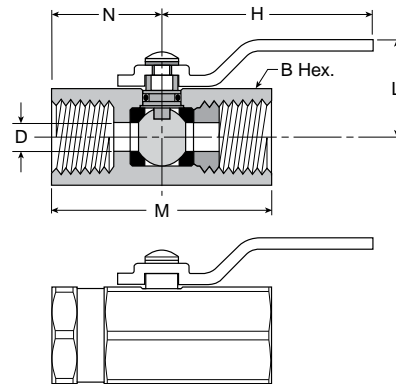

Part No.	Pipe Thread	B Hex.	H	L	M	N	Flow Dia. D
MV709-4	1/4	11/16	1.52	.70	1.57	.76	.210



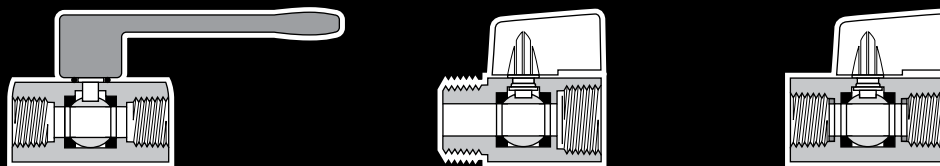

Mini Ball Valves Series 200 / 608 / 609

Advantages

The Parker Mini-Valve is to be used in confined and hard to reach applications. The Brass extruded body allows for extended service life and is chrome plated as standard. Features of the MV608/609 valves include blowout proof stem, hard chrome plate ball, PTFE seats, viton stem seals, and standard yellow handle. MV200 valve features a black lever handle. This economical ball valve is available in 1/8", 1/4", 3/8" and 1/2" sizes.

Applications

Parker's industrial ball valve product line is intended for general purpose use. Please be aware that ball valves are intended for use in the fully open or closed positions. Depending on application conditions, throttling of the valve may result in premature seal failure and/or inability to turn the valve handle.

For use on water and air service lines on capital equipment and plant design plumbing that require total shutoff capability.

Working Pressure and Temperatures

These valves are designed and built for use at pressures and temperatures within the stated ranges. Consult the factory for any use outside of these ranges.

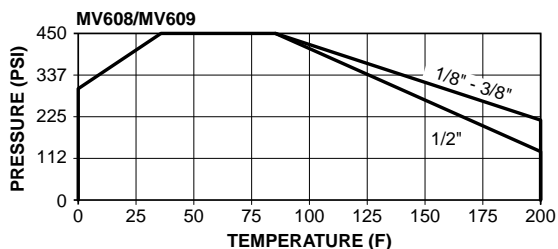
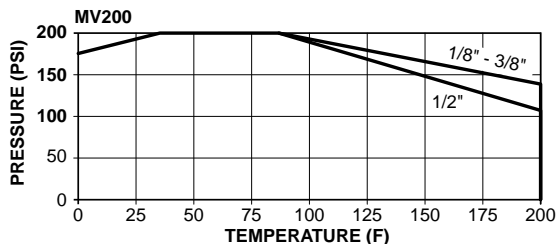

Operating Instructions

Quarter turn is "ON" or "OFF".
(Provides Positive stop action for full shutoff.)

Style	Type	Size
MV	608	2
	609	
Style	MV – Mini Valve	
Type	608 – Male / Female	
	609 – Female / Female	
Handle Color	MV200 Features Black Lever Handle MV608, MV609 Features Yellow Wedge Lever Handle	
Size	2 - 1/8"	
	4 - 1/4"	
	6 - 3/8"	
	8 - 1/2"	

Style	Type	Size
MV	200	2
Style	MV – Mini Valve	
Type	200 – Female / Female Lever Handle	
Size	2 - 1/8"	
	4 - 1/4"	
	6 - 3/8"	
	8 - 1/2"	

Flow Data

Valve Size	MV200 Cv	MV608 Cv	MV609 Cv
1/8	1.3	1.2	1.4
1/4	4.0	5.8	4.3
3/8	3.7	3.9	3.6
1/2	5.8	5.6	6.0



MV200 Female Pipe Ends, Lever Handle, Mini Ball Valve

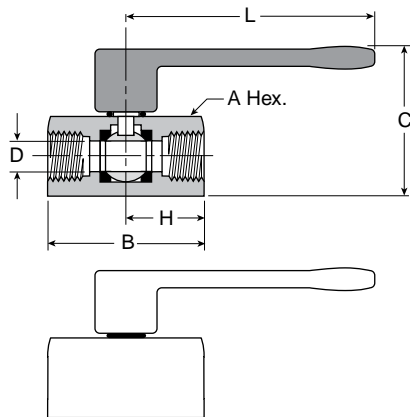

Part No.	Pipe Thread	A Hex.	B	C	H	L	Flow Dia. D
MV200-2	1/8	.83	1.71	1.20	.91	2.83	.31
MV200-4	1/4	.83	1.71	1.20	.91	2.83	.31
MV200-6	3/8	.83	1.71	1.20	.91	2.83	.31
MV200-8	1/2	.98	2.11	1.28	1.10	2.83	.39

MV609 Female Pipe Ends, Compact Handle, Mini Ball Valve

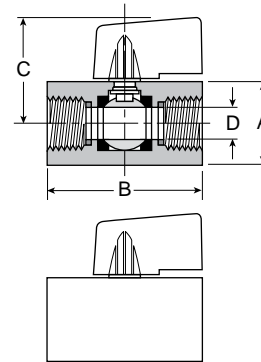

Part No.	Pipe Thread	A Hex.	B	C	Flow Dia. D
MV609-2	1/8	.83	1.72	1.12	.240
MV609-4	1/4	.83	1.72	1.12	.300
MV609-6	3/8	.83	1.72	1.12	.300
MV609-8	1/2	.98	2.11	1.20	.380
MV609-6-4	3/8 x 1/4	.83	1.72	1.12	.300

MV608 Male-Female Pipe Ends, Compact Handle, Mini Ball Valve

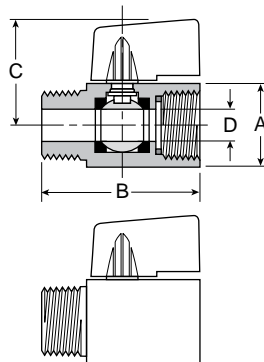

Part No.	Pipe Thread	A Hex.	B	C	Flow Dia. D
MV608-2	1/8	.83	1.72	1.12	.240
MV608-4	1/4	.83	1.72	1.12	.300
MV608-6	3/8	.83	1.72	1.22	.315
MV608-8	1/2	.98	2.11	1.20	.380



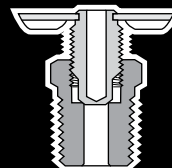
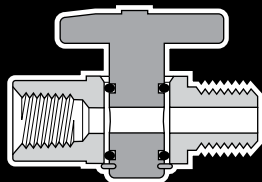

Plug Valves Series PV & Drain Cocks Series DC

Plug Valve Advantages

Compact design features internal nitrile seals and a one-piece extruded brass body, offering compatibility with a wide range of media. The one-piece stem/handle combination is constructed of glass reinforced acetal copolymer. Parker plug valves feature 1/4 turn shutoff allowing for ease of operation. All plug valves are 100% leak tested and are certified to be leak free to one SCCM.

Drain Cock Advantages

Both external-seat and internal-seat drain cocks are manufactured to the highest quality standards. Hand-tightening provides a metal-to-metal seal.

Materials

Extruded Bodies: CA 360

Stem / Handle: Acetal Copolymer

O-Rings: Nitrile (other compounds available)

Stop Pin: 420SS

Spiral Ring: 302SS

Temperature and Working Pressure Ranges

From -40° to +175°F at 250 PSI maximum.

Applications

Manufactured for use with air, water, oil and certain other fluids. Contact factory for special fluid requirements.

Installation Instructions

To assure sealability and reliable performance, the valve must be installed so that the flow media travels in the direction of the arrow on the valve handle.

Nomenclature

Part numbers are constructed from symbols that identify the style and size of the fitting. The first series of numbers and letters identifies the style and type fitting. The second series of numbers describes the size.

Example: PV 607 2

Plug Valve _____
 Male to Male _____
 1/8" (2/16) Male _____

Example: DC 602 2

Drain Cock _____
 INternal Seal _____
 1/8" (2/16) Male _____

Plug Valve Features

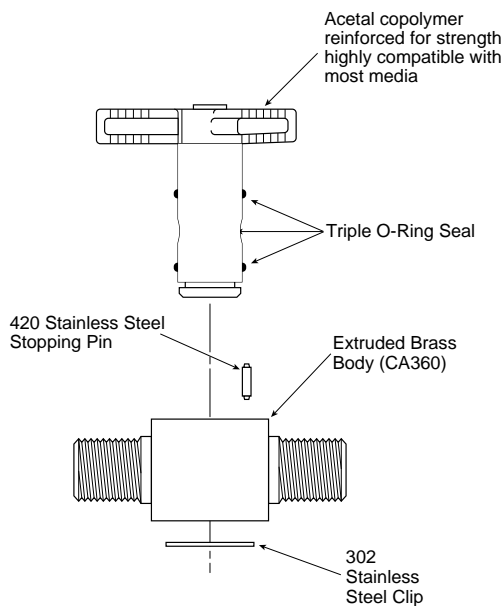

F



Part Numbers & Dimensions

Plug Valves & Drain Cocks
1/8" to 3/8" Pipe

PV607 Male Pipe to Male Pipe Plug Valve

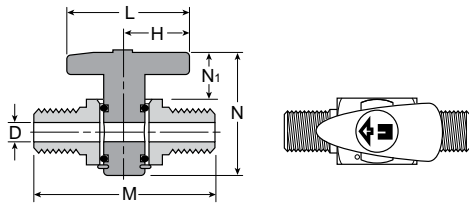

Part No.	Pipe Thread	H	L	M	N	N ₁	Flow Dia. D
PV607-2	1/8	0.67	1.34	1.66	1.38	0.51	0.200
PV607-4	1/4	0.67	1.34	2.02	1.38	0.51	0.200

DCR601 Drain Cock
(Temperature Range: -30° to +250° F)

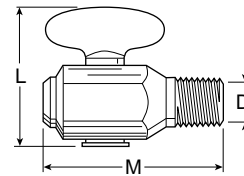

Part No.	Pipe Thread	L	M	Flow Dia. D
DCR601-4	1/4	1.41	1.73	.188

PV608 Female Pipe to Male Pipe Plug Valve

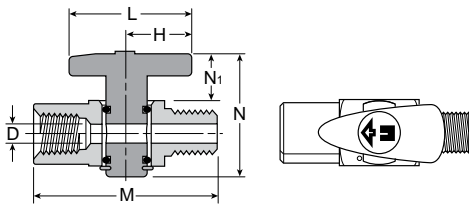

Part No.	Pipe Thread	H	L	M	N	N ₁	Flow Dia. D
PV608-2	1/8	0.67	1.34	1.67	1.38	0.51	0.200
PV608-4	1/4	0.67	1.34	2.06	1.38	0.51	0.200

DC602 Internal Seal Drain Cock
(Temperature Range: -65° to +250° F)

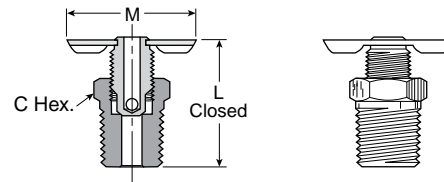

Part No.	Pipe Thread	C Hex.	L	M
DC602-2	1/8	13/32	0.92	1.25
DC602-4	1/4	9/16	0.94	1.25

PV609 Female Pipe to Female Pipe Plug Valve

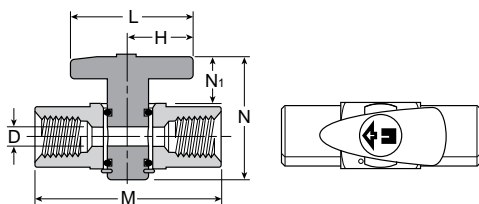

Part No.	Pipe Thread	H	L	M	N	N ₁	Flow Dia. D
PV609-2	1/8	0.67	1.34	1.68	1.38	0.51	0.200
PV609-4	1/4	0.67	1.34	2.10	1.38	0.51	0.200

DC603 Drain Cock
(Temperature Range: -65° to +250° F)

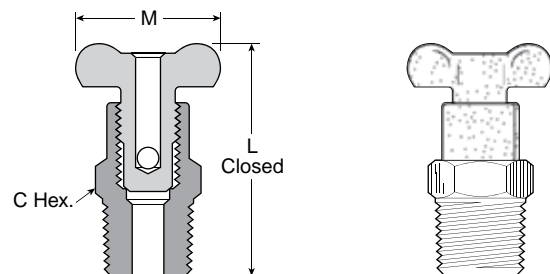

Part No.	Pipe Thread	C Hex.	L	M
DC603-2	1/8	1/2	1.41	1.00
DC603-4	1/4	5/8	1.54	1.16
DC603-6	3/8	11/16	1.63	1.16



Part Numbers & Dimensions

**Drain Cocks
1/8" to 3/8" Pipe**

DC604 External Seal Drain Cock
(Temperature Range: -25° to +250° F)

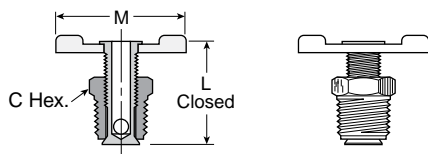

Part No.	Pipe Thread	C Hex.	L	M
DC604-2*	1/8	7/16	0.85	1.25
DC604-4	1/4	9/16	1.00	1.38
DC604-6*	3/8	11/16	1.22	1.68

*When assembled handle wings are down facing

DC607 Bib Drain Valve
(Temperature Range: -65° to +250° F)

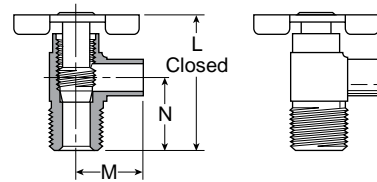

Part No.	Hose Size	Pipe Thread	Flow	L	M	N
DC607-4	3/8	1/4	0.31	1.32	0.67	0.71

DC606 External Seal Drain Cock
(Temperature Range: -65° to +250° F)

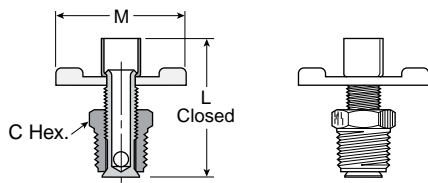

Part No.	Pipe Thread	C Hex.	L	M
DC606-4	1/4-18	9/16	1.50	1.38





Safety Blow Guns

Section F

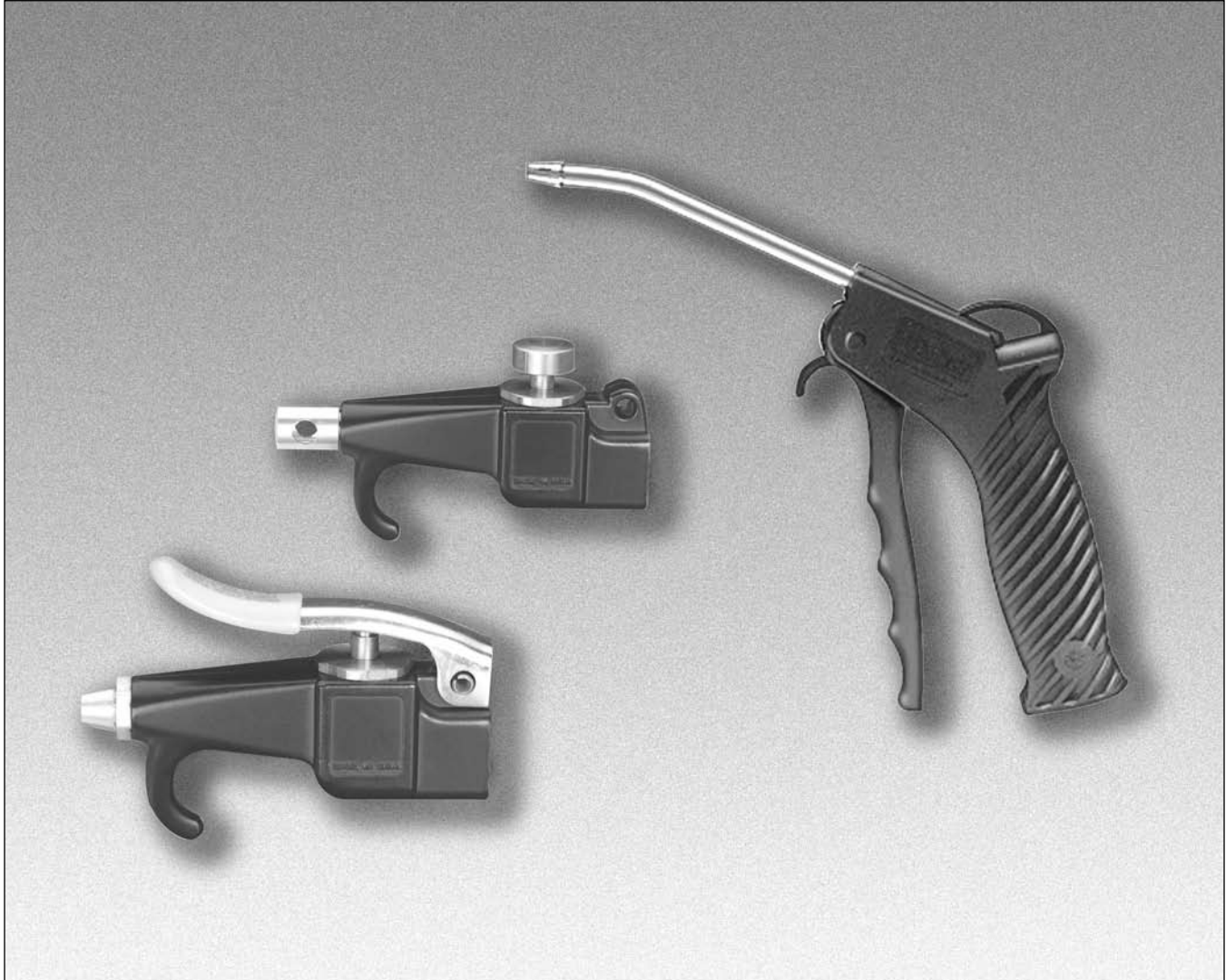

F

Brass Nozzle & Aspirator Blow Guns	F90
Vortec FLO-GAIN & Self Regulating Blow Guns.....	F91
Pistol Grip Blow Guns	F92
Blow Gun Accessories	F93
Replacement Parts.....	F94

O.S.H.A. Certification — All safety blow guns conform to the requirements of Compressed Air Standards as currently described in the U.S. Bureau of Labor Standards, paragraph 1910.242, when pressurized at the inlet to a maximum of 100 PSIG. Conform to current O.S.H.A. Directive No. 100-1.



Brass Nozzle Blow Guns

Contoured lever or button control both provide a natural, comfortable grip even when used with gloves. Finger guard and hang-up hook for finger protection and quick safe storage. Die cast zinc body, painted finish.

Lever Operated

Part Number	Inlet Port	SCFM Rating*
00475 0010	1/4"	20

Button Operated

Part Number	Inlet Port	SCFM Rating*
00470 0010	1/4"	20

*Based on 100 PSIG inlet pressure.

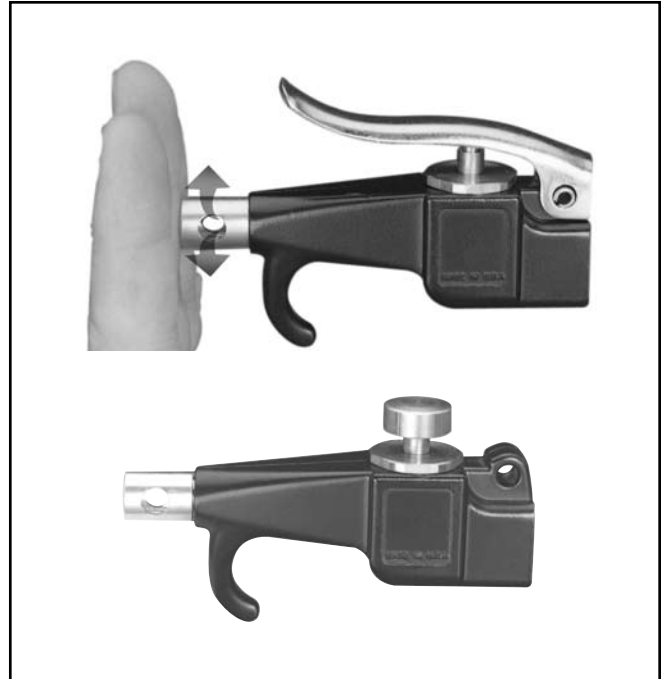

Aspirator Blow Guns

Dual air shield provides wide fan of air to reduce chip blow back. Secondary shielding is provided by four radial holes for close in work. Aspirator nozzle gives heavy duty chip blowing performance without exceeding legal limits. Pressure relieves to safe limits if nozzle is blocked. Finger guard and hang-up hook offer desirable finger protection and quick secure storage. Die cast zinc body, painted finish.

Lever Operated

Part Number	Inlet Port	SCFM Rating*
00475 0474	1/4"	74.5

Button Operated

Part Number	Inlet Port	SCFM Rating*
00470 0474	1/4"	74.5

*Based on 100 PSIG inlet pressure.

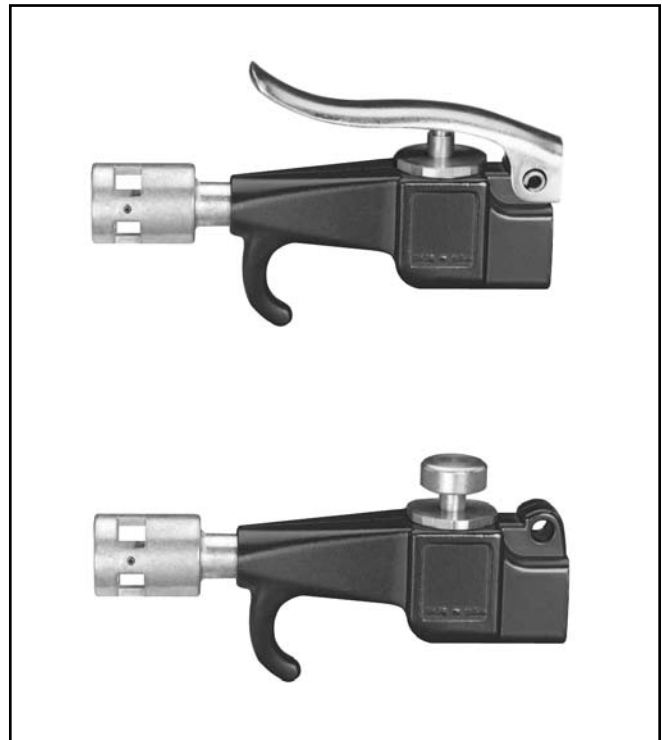

F

Vortec FLO-GAIN Blow Guns

A quiet Vortec FLO-GAIN nozzle is combined with a high performance blow gun. Compressed air attains sonic velocity through an adjustable slot and attaches to the exterior surface of the cone shaped nozzle. Settings are shown on a micrometer dial. Sound level of 80 dBA with 80 PSIG inlet. Finger guard and hang-up hook offers desirable finger protection and quick secure storage. Die cast zinc body, painted finish.

Lever Operated

Part Number	Inlet Port	SCFM Rating*
00475 0900	1/4"	70+

Button Operated

Part Number	Inlet Port	SCFM Rating*
00470 0900	1/4"	70+

*Based on 100 PSIG inlet pressure.

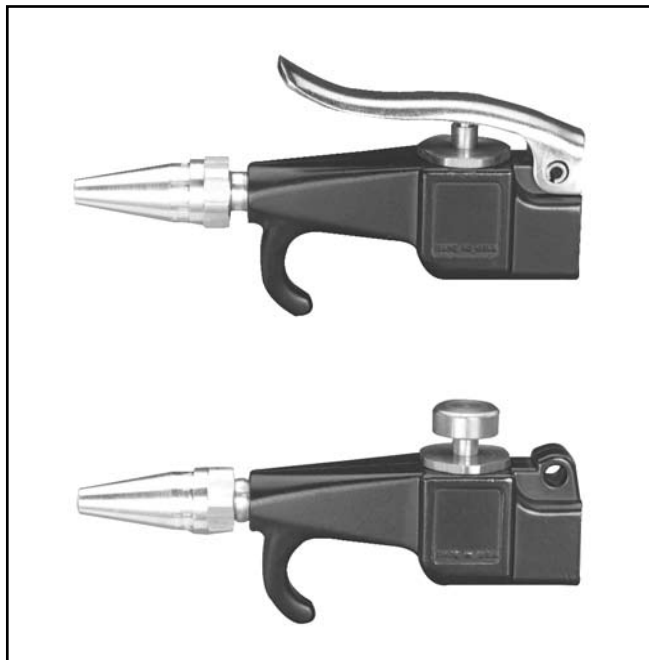

Self-Regulating Blow Gun

Designed with integral self-regulating pressure reducing valve for automatic shut-off when nozzle is blocked. Prevents air pressure buildup over 30 PSIG in compliance with U.S. Dept. of Labor standards.

Air shield aids in protecting the operator against blow back of flying chips or dirt. Designed to operate at less than 90 dBA to comply with government regulations. Die cast zinc body, painted finish.

May be used with nozzle extensions on page C5.

Lever Operated

Part Number	Inlet Port	SCFM Rating*
00475 2900	1/4"	10

Performance Data

Inlet Pressure	Blocked Pressure	Sound Level
70 PSIG	17.0 PSIG	79 dBA
100 PSIG	21.0 PSIG	83 dBA
175 PSIG	28.0 PSIG	87 dBA

*Based on 100 PSIG inlet pressure.



Pistol Grip Blow Gun

Pistol grip is easy to aim for quick and efficient cleaning. Ideal for all shop housekeeping purposes. Lightweight and easy to handle. Easy trigger action features instant spring adjustment for controlled air. Get the amount of air where you want it with no restrictions, no cut-offs! Makes for a convenient connection for overhead or underbench floor air use.

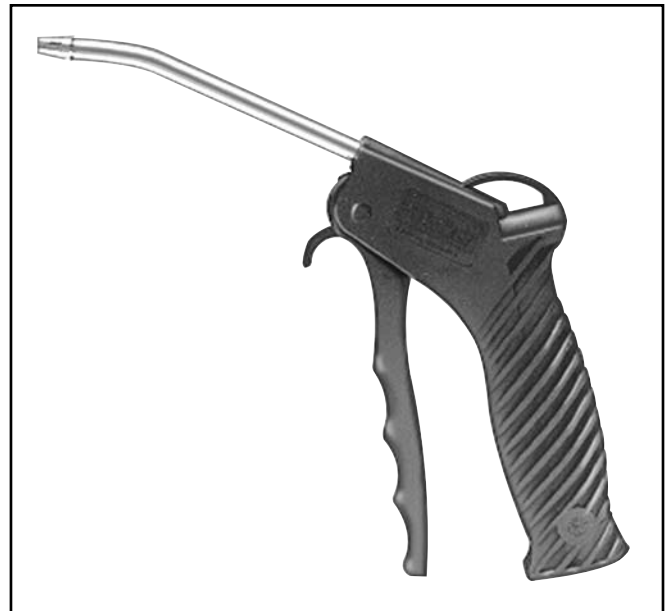

Part Number	Inlet Port	Rated Pressure	Temperature Range	OSHA Rated
BG441-NBL	1/4"	175 PSI	120° F	No

F

Accessories**Brass Nozzle****Model No. 00470 7020**

General purpose nozzles are supplied as standard on 00470 0010, 00475 0010 and 07184 1000 blow guns. Conform to the requirements of the Williams Steiger Occupational Safety and Health Act of 1970, paragraph 1910.242 when fitted with blow guns pressurized at the inlet to a maximum of 100 PSIG. Conform to O.S.H.A. Directive 100-1.

**Aspirator Nozzle****Model No. 00474 1000**

Protect against personal injury by relieving pressure if the nozzle end is blocked. Develop exceptionally high flow rates which insure effective cleaning. Conform to the requirements of the Williams Steiger Occupational Safety and Health Act of 1970, paragraphs 1910.95 and 1910.242 when fitted with blow guns pressurized at the inlet to a maximum of 100 PSIG. Conform to O.S.H.A. Directive 100-1.

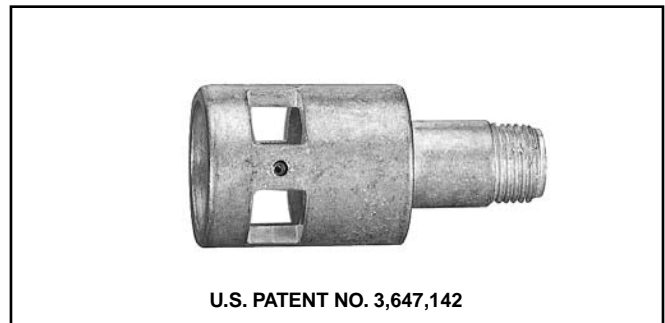
**FLO-GAIN Nozzle****Model No. W1110 0900**

This FLO-GAIN nozzle is the most widely used of the transvector products for industrial blow off. Compressed air attains sonic velocity through an adjustable slot and attaches to the cone shaped exterior surface of the nozzle. Induction and entrainment take place outside the nozzle. Factory slot setting is .008 inch, but is adjustable from closed to .012 inch. A micrometer dial allows adjustment without the use of shims or gauges.

Must be used with filtered air.

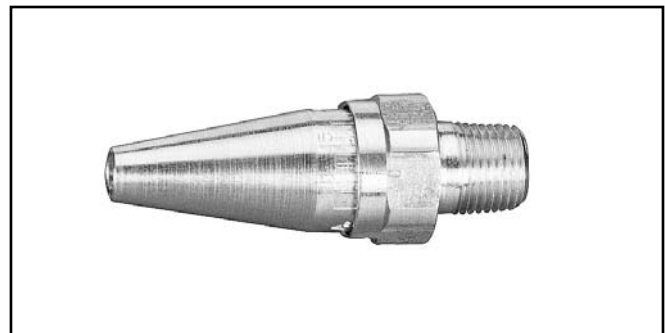

470 and 475 Series Blow Guns

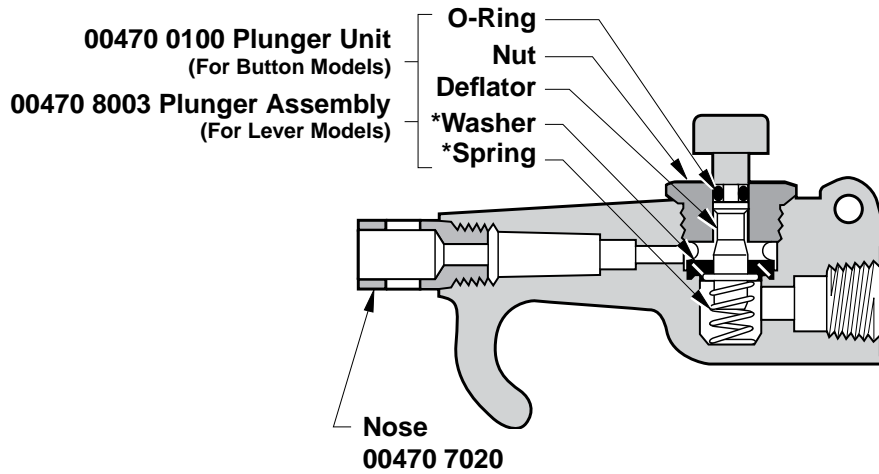

* Contained in Service Kit No. 00470 0090

F

Section F



Push-on Hose Fittings

Basic Features	F96
Part Numbers & Dimensions	F97-F99
General Purpose Hose.....	F100-F101
Selection Guide	F102-F103
Chemical Compatibility Guide (GPH).....	F104-F105

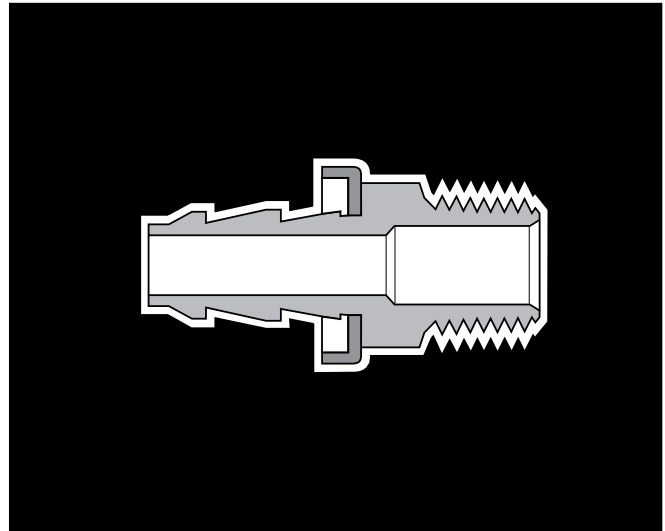

Advantages

Push-on Hose Fittings are machined from the highest quality brass or stainless steel. The barbs are specifically engineered to work in conjunction with the I.D. and braid angle of Push-on Hose, ensuring a tight connection **without clamps**.

Assembly

Push-on Hose Fittings are designed only for use with Push-on Hose. Do not use with any other style or manufacturer of hose.

Assembly Instructions:

1. Cut hose cleanly and squarely to length.
2. Lubricate hose I.D. and barbs with light oil or soapy water.
3. Push the hose onto the fitting until it bottoms against the yellow stop ring. This ensures that all of the barbs are engaged with the hose and will also help keep the end of the hose from fraying.
4. **⚠ CAUTION: Use of clamps may damage sealing integrity of Hose and Fitting Assembly.**

Temperature Range

-40°F to 180°F (-40°C to 82°C)

Limited by media through hose assembly.

Pressure Range

Limited by hose I.D.

Nomenclature

Part numbers are constructed from symbols that identify the style, size and material of the fitting.

Example:

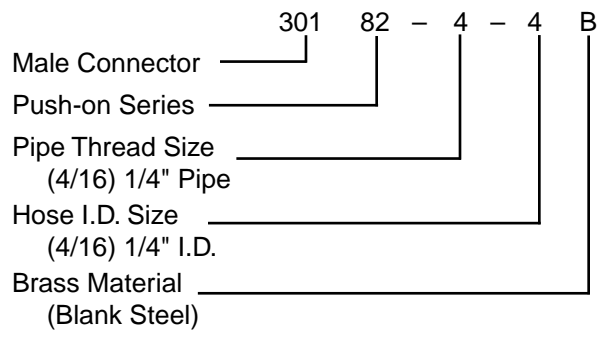

F



30182 Push-on Hose Barb to Male Pipe

#	Thread		Hose Size		A		H	B	
	Inch		Inch		Inch	mm		Inch	mm
30182-2-4B	1/8 x 27	-2	1/4	-4	1.39	35	7/16	.64	16
30182-4-4B	1/4 x 18	-4	1/4	-4	1.57	40	9/16	.82	21
30182-4-6B	1/4 x 18	-4	1/4	-4	1.78	45	9/16	.88	22
30182-6-6B	3/8 x 18	-6	3/8	-6	1.78	45	11/16	.88	22
30182-8-6B	1/2 x 14	-8	3/8	-6	2.03	52	7/8	1.13	29
30182-6-8B	3/8 x 18	-6	1/2	-8	1.93	49	11/16	.88	22
30182-8-8B	1/2 x 14	-8	1/2	-8	2.18	55	7/8	1.13	29
30182-12-8B	3/4 x 14	-12	1/2	-8	2.21	56	1-1/16	1.16	29
30182-8-10B	1/2 x 14	-8	5/8	-10	2.58	66	7/8	1.13	29
30182-12-12B	3/4 x 14	-12	3/4	-12	2.61	66	1-1/16	1.16	29

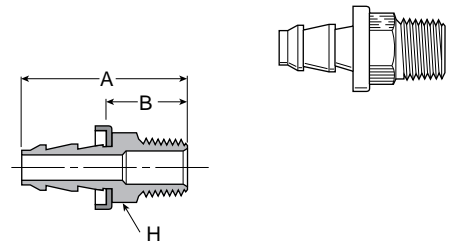

30282 Push-on Hose Barb to Male Pipe

#	Thread		Hose Size		A		H	B	
	Inch		Inch		Inch	mm		Inch	mm
30282-4-4B	1/4 x 18	-4	1/4	-4	1.56	40	3/4	.81	21
30282-6-6B	3/8 x 18	-6	3/8	-6	1.82	46	7/8	.92	23
30282-8-8B	1/2 x 14	-8	1/2	-8	2.16	55	1-1/16	1.11	28

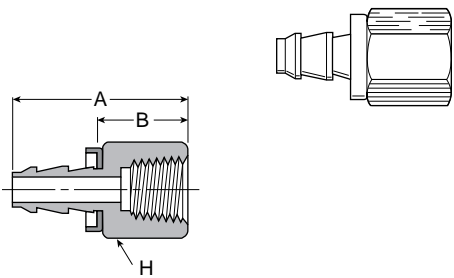

30482 Push-on Hose Barb to Male SAE 45°

#	Thread		Hose Size		A		H	B		
	Inch		Inch		Inch	mm		Inch	mm	
30482-4-4B	1/4	7/16 x 20	-4	1/4	-4	1.51	38	7/16	0.76	19
30482-5-4B	5/16	1/2 x 20	-5	1/4	-4	1.61	41	9/16	0.86	22
30482-6-6B	3/8	5/8 x 18	-6	3/8	-6	1.84	47	5/8	0.94	24
30482-8-8B	1/2	3/4 x 16	-8	1/2	-8	2.15	55	3/4	1.1	28

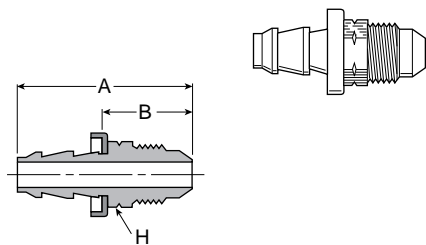

30682 Push-on Hose Barb to Female SAE JIC 37° Swivel

# Part No.	Thread Inch			Hose Size Inch		A		H	B	
	Inch	mm	Inch	Inch	mm	Inch	mm	Inch	mm	
30682-4-4B	1/4	7/16 x 20	-4	1/4	-4	1.52	39	9/16	0.77	20
30682-5-4B	5/16	1/2 x 12	-5	1/4	-4	1.58	40	5/8	0.83	21
30682-6-6B	3/8	9/16 x 18	-6	1/4	-4	1.61	41	11-16	0.86	22
30682-8-6B	1/2	3/4 x 16	-8	3/8	-6	1.87	47	7/8	0.97	25
30682-8-8B	1/2	3/4 x 16	-8	1/2	-8	2.02	51	7/8	0.97	25
30682-10-8B	5/8	7/8 x 14	-10	1/2	-8	2.14	54	1	1.09	28
30682-10-10B	5/8	7/8 x 14	-10	5/8	-10	2.54	65	1	1.09	28
30682-12-12B	3/4	1-1/16 x 12	-12	3/4	-12	2.65	67	1-1/4	1.2	30

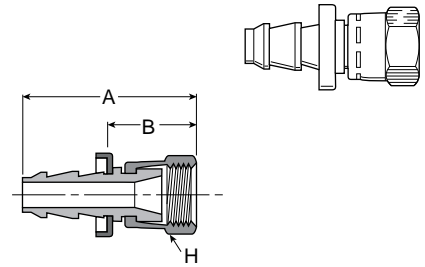

30882 Push-on Hose Barb to Female SAE 45° Swivel

# Part No.	Thread Inch			Hose Size Inch		A		H	B	
	Inch	mm	Inch	Inch	mm	Inch	mm	Inch	mm	
30882-4-4B	1/4	7/16 x 20	-4	1/4	-4	1.52	39	9/16	0.76	19
30882-5-4B	5/16	1/2 x 20	-5	1/4	-4	1.58	40	5/8	0.83	21
30882-6-6B	3/8	5/8 x 18	-6	3/8	-6	1.81	46	3/4	0.91	23
30882-8-6B	1/2	3/4 x 16	-8	3/8	-6	1.87	47	7/8	0.97	25
30882-8-8B	1/2	3/4 x 16	-8	1/2	-8	2.02	51	7/8	0.97	25
30882-10-8B	5/8	7/8 x 14	-10	1/2	-8	2.14	54	1	1.09	28
30882-10-10B	5/8	7/8 x 14	-10	5/8	-10	2.54	65	1	1.09	28
30882-12-12B	3/4	1-1/16 x 14	-12	3/4	-12	2.65	67	1-1/4	1.19	30

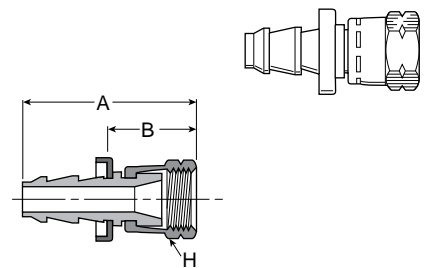

31382 Push-on Hose Barb to Male Pipe Swivel

# Part No.	Thread Inch		Hose Size Inch		A		H	B	
	Inch	mm	Inch	mm	Inch	mm	Inch	mm	
31382-4-4	1/4 x 18	-4	1/4	-4	1.6	41	9/16	.85	22
31382-6-6	3/8 x 18	-6	3/8	-6	1.79	45	11/16	.89	23
31382-8-8*	1/2 x 14	-8	1/2	-8	2.2	56	7/8	1.15	29

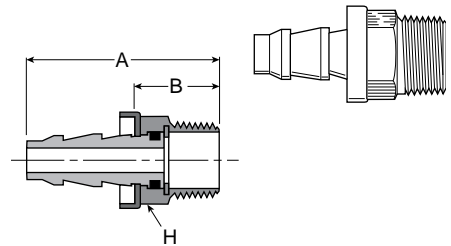

* Steel

F

37G82 Push-on Hose Barb to Female Pipe (NPSM)

Swivel with Gasket

# Part No.	Gasket	Thread		Hose Size		A		H	B	
		Inch	-	Inch	-	Inch	mm	Inch	Inch	mm
37G82-4-4	07G-4	1/4- 18	-4	1/4	-4	1.55	39	11/16	0.80	20
37G82-4-6	07G-4	1/4- 18	-4	3/8	-6	1.7	43	11/16	0.80	20
37G82-6-6	07G-6	3/8- 18	-6	3/8	-6	1.75	44	7/8	0.85	22
37G82-8-8	07G-8	1/2- 14	-8	1/2	-8	2.07	53	1	1.02	26
37G82-8-10	07G-8	1/2- 14	-8	5/8	-10	2.47	63	1	1.02	26
37G82-12-12	07G-12	3/4- 14	-12	3/4	-12	2.54	65	1-1/4	1.09	28

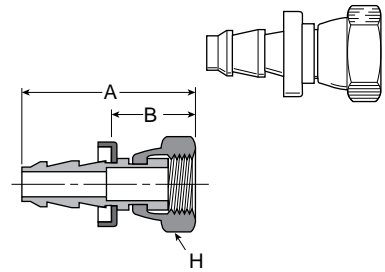

38282 Push-on Hose Barb Union

# Part No.	Hose Size		A	
	Inch	-	Inch	mm
38282-4-4B	1/4	-4	1.80	46
38282-6-6B	3/8	-6	2.15	55
38282-8-8B	1/2	-8	2.51	64

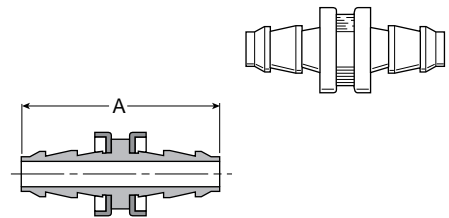

Synthetic Rubber Hose Reel (RL) or Box (BX) Footage

Hose Type	I.D.	Approx. Reel Size (Feet)	Maximum Number of Lengths on Reel	Minimum Feet of Hose in Each Length	Hose Box (BX) Footage (Feet)
Push-on 801-4	1/4"	500 ± 50	4	50	50
Push-on 801-6	3/8"	370 ± 37	4	50	50
Push-on 801-8	1/2"	240 ± 24	3	50	50
Push-on 801-10	5/8"	250 ± 25	3	50	50
Push-on 801-12	3/4"	200 ± 20	3	50	50
Push-on 801-16	1"	150 ± 15	3	50	50

F

Features & Dimensions



The Push-Lok Plus line is the most versatile general purpose hose available. It can be used in numerous applications where low-pressure media is used.

Features and Benefits

- Widest fluid compatibility and application range
- Broadest size range (-4 through -16)
- Highest working pressure in all sizes in the industry

Construction

- Inner tube: Synthetic Rubber
- Reinforcement: One Fiber Braid
- Cover: Synthetic Rubber, MSHA Accepted

Temperature

- Petroleum base hydraulic fluids, lubricating oils, and antifreeze solutions -40°F to +257°F (-40°C to +125°C)
- Water, water / oil emulsion, and water / glycol fluids up to +185°F (+85°C)
- Air up to +158°F (+70°C)

Water Service

Water, water/oil emulsion, and water/glycol hydraulic fluids up to +185°F (+85°C). Air up to +158°F (+70°C).

Fitting Recommendations

Use only with Push-on Hose Fittings and Quick Couplers with Push-lock Hose Barb.

Note: Push-Lok hose is recommended for vacuum applications but not for cooling lines in air conditioners and heat pumps, nor for hydraulic applications where extreme pulsations are encountered. Push-Lok is not recommended for any fuel.

Nomenclature

Part numbers are constructed from symbols that identify the style and size of the hose. Numbers identify the hose I.D. in 1/16's of an inch.

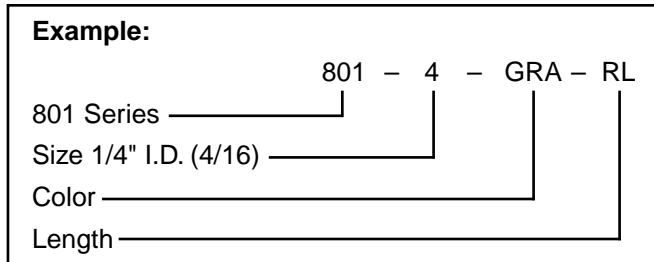

Note: 801-10-GRN-RL Not Available

Available Cover Colors

- GRA = gray
- RED = red
- YEL = yellow
- BLU = blue
- GRN = green
- BLK = black

Hose Length

Hose Type	I.D.	Reel Length
801-4	1/4"	600 feet
801-6	3/8"	450 feet
801-8	1/2"	300 feet
801-10	5/8"	250 feet
801-12	3/4"	200 feet
801-16	1"	200 feet

Push-on Hose 801 Push-Lok Plus

#	Hose I.D.		Hose O.D.		Working Pressure		Burst Pressure		Minimum Bend Radius		Weight		Vacuum Rating	
	Inch	mm	Inch	mm	PSI	MPa	PSI	MPa	Inch	mm	lbs/ft	kg/m	Inches of Hg	kPa
801-4	1/4	6,3	0.50	12,7	350	2.4	1000	6,8	2-1/2	65	0.09	0.13	28	95
801-6	3/8	10	0.63	15,9	350	2.4	1000	6,8	3	75	0.11	0.16	28	95
801-8	1/2	12,5	0.78	19,8	300	2.1	1000	6,8	5	125	0.18	0.27	28	95
801-10	5/8	16	0.91	23,0	300	2.1	1000	6,8	6	150	0.19	0.28	15	51
801-12	3/4	19	1.03	26,2	300	2.1	1000	6,8	7	180	0.24	0.36	15	51
801-16	1	25	1.28	32,6	200	1.4	700	4,8	10	250	0.37	0.55	15	51



⚠ DANGER: Failure or improper selection or improper use of hose, fittings, or related accessories can cause death, personal injury and property damage.

Possible consequences of failure or improper selection or improper use of hose, fittings or related accessories include but are not limited to:

- Fittings thrown off at high speed.
- High velocity fluid discharge.
- Explosion or burning of the conveyed fluid.
- Electrocutation from high voltage electric power lines or other sources of electricity.
- Contact with suddenly moving or falling objects that are to be held in position or moved by the conveyed fluid.
- Dangerously whipping hose.
- Contact with conveyed fluids that may be hot, cold, toxic or otherwise injurious.
- Sparking or explosion caused by static electricity buildup.
- Sparking or explosion while paint or flammable liquid spraying.

Before selecting or using any hose or fittings or related accessories, it is important that you read and follow the instructions in the Guide below.

1.0 GENERAL INSTRUCTIONS

1.1 Scope: This guide provides instructions for selecting and using (including assembling, installing, and maintaining) hose (including all rubber and/or plastic products commonly called "hose" or "tubing"), fittings (including all products commonly called "fittings" or "couplings" for attachment to hose), and related accessories (including crimping and swaging machines and tooling). This guide is a supplement to and is to be used with, the specific publications for the specific hose, fittings and related accessories that are being considered for use.

1.2 Fail-Safe: Hose and hose assemblies can and do fail without warning for many reasons. Design all systems and equipment in a fail-safe mode, so that failure of the hose or hose assembly will not endanger persons or property.

1.3 Distribution: Provide a copy of this guide to each person that is responsible for selecting or using hose and fitting products. Do not select or use hose and fittings without thoroughly reading and understanding this guide as well as the specific publications for the products considered or selected.

1.4 User Responsibility: Due to the wide variety of operating conditions and uses for hose and fittings, the manufacturer and its distributors do not represent or warrant that any particular hose or fitting is suitable for any specific and use system. This guide does not analyze all technical parameters that must be considered in selecting a product. The user, through their own analysis and testing, are solely responsible for:

- Making the final selection of the hose and fitting.
- Assuring that the user's requirements are met and that the use presents no health or safety hazards.
- Providing all appropriate health and safety warnings on the equipment on which the hose and fittings are used.

1.5 Additional Questions: Consult the supplier if you have any additional questions or require additional information.

2.0 HOSE AND FITTING SELECTION INSTRUCTIONS

2.1 Electrical Conductivity: Certain applications require that a hose be nonconductive to prevent electrical current flow. Other applications require the hose to be sufficiently conductive to drain off static electricity. Extreme care must be exercised when selecting hose and fittings for these or any other applications in which electrical conductivity or nonconductivity is a factor.

For applications that require hose to be electrically nonconductive, including but not limited to applications near high voltage electric lines, only special nonconductive hose can be used. The manufacturer of the equipment in which the nonconductive hose is to be used must be consulted to be certain that the hose and fittings that are selected are proper for the application. Do not use any hose or fitting for any such application requiring nonconductive hose, including but not limited to applications near high voltage electric lines, unless (I) the application is expressly approved in the technical publication for the product, (II) the hose is both orange color and marked "nonconductive", and (III) the manufacturer of the equipment on which the hose is to be used specifically approves the particular hose and fitting for such use.

The manufacturer does not supply any hose or fittings for conveying paint in airless paint spraying or similar applications, and hose and

fittings must not be so used. A special hose and fitting assembly is required for this application, to avoid static electricity buildup. If the proper hose and fitting assembly is not used for this application, static electricity can build up and cause a spark that may result in an explosion and/or fire.

The electrical conductivity or nonconductivity of hose and fittings is dependent upon many factors and may be susceptible to change. These factors include but are not limited to the various materials used to make the hose and the fittings, manufacturing methods (including moisture control), how the fittings contact the hose, age and amount of deterioration or damage or other changes, moisture content of the hose at any particular time, and other factors.

2.2 Pressure: Hose selection must be made so that the published maximum recommended working pressure of the hose is equal to or greater than the maximum system pressure. Surge pressures in the system higher than the published maximum recommended working pressure will cause failure or shorten hose life. Do not confuse burst pressure or other pressure values with working pressure and do not use burst pressure or other pressure values for this purpose.

2.3 Suction: Hoses used for suction applications must be selected to ensure that the hose will withstand the vacuum and pressure of the system. Improperly selected hose may collapse in suction application.

2.4 Temperature: Be certain that fluid and ambient temperatures, both steady and transient, do not exceed the limitations of the hose. Care must be taken when routing hose near hot objects such as manifolds.

2.5 Fluid Compatibility: Hose selection must assure compatibility of the hose tube, cover, reinforcement, and fittings with the fluid media used. See the fluid compatibility chart in the publication for the product being considered or used.

2.6 Permeation: Permeation (that is, see page through the hose) will occur from inside the hose to outside when hose is used with gases, liquid and gas fuels, and refrigerants (including but not limited to such materials as helium, fuel, oil, natural gas, or freon). This permeation may result in high concentrations of vapors which are potentially flammable, explosive, or toxic, and in loss of fluid. Dangerous explosions, fires, and other hazards can result when using the wrong hose for such applications. The system designer must take into account the fact that this permeation will take place and must not use hose if this permeation could be hazardous. The system designer must take into account all legal, government, insurance, or any other special regulations which govern the use of fuels and refrigerants. Never use a hose even though the fluid compatibility is acceptable without considering the potential hazardous effects that can result from permeation through the hose assembly.

Permeation of moisture from outside the hose to inside the hose will also occur in hose assemblies, regardless of internal pressure. If this moisture permeation would have detrimental effects (particularly but not limited to refrigeration and air conditioning systems), incorporation of sufficient drying capacity in the system or other appropriate system safeguards should be selected and used.

- 2.7 Size:** Transmission of power by means of pressurized fluid varies with pressure and rate of flow. The size of the components must be adequate to keep pressure losses to a minimum and avoid damage due to heat generation or excessive fluid velocity.
- 2.8 Routing:** Attention must be given to optimum routing to minimize inherent problems (kinking or flow restriction due to hose collapse). Freon® is a registered trademark of the E.I. DuPont De Nemours Co., Inc.
- 2.9 Environment:** Care must be taken to ensure that the hose and fittings are either compatible with or protected from the environment (that is, surrounding conditions) to which they are exposed. Environmental conditions include but are not limited to ultraviolet radiation, sunlight, heat, ozone, moisture, water, salt water, chemicals, and air pollutants that can cause degradation and premature failure.
- 2.10 Mechanical Loads:** External forces can significantly reduce hose life or cause failure. Mechanical loads which must be considered include excessive flexing, twist, kinking, tensile or side loads, bend radius, and vibration. Use of swivel type fittings or adapters may be required to ensure no twist is put into the hose. Applications must be tested prior to hose selection.
- 2.11 Physical Damage:** Care must be taken to protect hose from wear, snagging and cutting, which can cause premature hose failure.
- 2.13 Length:** When establishing a proper hose length, motion absorption, hose length changes due to pressure, and hose and machine tolerances must be considered.
- 2.14 Specifications and Standards:** When selecting hose and fittings, government, industry, and manufacturer specifications and recommendations must be reviewed and followed as applicable.
- 2.15 Hose Cleanliness:** Hose components may vary in cleanliness levels. Care must be taken to ensure that the assembly selected has an adequate level of cleanliness for the application.
- 2.16 Fire Resistant Fluids:** Some fire resistant fluids require the same hose as petroleum oil. Some use a special hose, while a few fluids will not work with any hose at all. See instructions 2.5 and 1.5. The wrong hose may fail after a very short service. In addition, all liquids may burn fiercely under certain conditions, and leakage may be hazardous.
- 2.17 Radiant Heat:** Hose can be heated to destruction without contact, by such nearby items as hot manifolds or molten metal. The same heat source may then initiate a fire. This can occur despite the presence of cool air around the hose.
- 2.18 Welding and Brazing:** Heating of plated parts, including hose fittings and adapters, above 450°F (232°C) such as during welding, brazing, or soldering may emit deadly gases.
- 2.19 Radiation:** Radiation affects all materials used in hose assemblies. Since the long term effects may be unknown, do not expose hose assemblies to radiation.
- 3.0 HOSE AND FITTING ASSEMBLY AND INSTALLATION INSTRUCTIONS**
- 3.1 Pre-Installation Inspection:** Prior to installation, a careful examination of the hose must be performed. All components must be checked for correct style, size, catalog number, and length. In addition, the hose must be examined for cleanliness, obstructions, blisters, cover looseness, or any other viable defects.
- 3.2 Hose and Fitting Assembly:** Do not assemble fittings onto a hose that is not specifically listed by the manufacturer for that fitting unless authorized in writing by the chief engineer. Do not assemble one manufacturer's fitting on another manufacturer's hose.
- The published instructions must be followed for assembling fittings on the hose. These instructions are provided in the fitting catalog for the specific fitting being used.
- 3.3 Related Accessories:** Do not crimp or swage any hose or fitting with anything but the proper listed swage or crimp machine, and dies, and in accordance with published instructions. Do not crimp or swage one manufacturer's hose fitting with another's crimp or swage die unless authorized in writing by their chief engineer.
- 3.4 Parts:** Do not use any hose fitting part (including but not limited to socket, shell, nipple, or insert) except with the correct mating parts, in accordance with instructions, unless authorized in writing by the chief engineer of the appropriate manufacturer.
- 3.5 Reusable/Permanent:** Do not reuse any reusable hose product that has blown or pulled off a hose. Do not reuse a permanent (that is, crimped or swaged) hose fitting or any part thereof.
- 3.6 Minimum Bend Radius:** Installation of a hose at less than the minimum listed bend radius may significantly reduce the hose life. Particular attention must be given to preclude sharp bending at the hose/fitting juncture.
- 3.7 Twist Angle and Orientation:** Hose installations must be such that relative motion of machine components does not produce twisting.
- 3.8 Securement:** In many applications, it may be necessary to restrain, protect, or guide the hose to protect it from damage by unnecessary flexing, pressure surges, and contact with other mechanical components. Care must be taken to ensure such restraints do not introduce additional stress or wear points.
- 3.9 Proper Connection of Ports:** Proper physical installation of the hose requires a correctly installed port connection while ensuring that no twist or torque is transferred to the hose.
- 3.10 External Damage:** Proper installation is not complete without ensuring that tensile loads, side loads, kinking, flattening, potential abrasion, thread damage, or damage to sealing surfaces are corrected or eliminated. See instruction 2.10.
- 3.11 System Checkout:** All air entrapment in hydraulic lines must be eliminated, all systems must be pressurized to the maximum system pressure and checked for proper function and freedom from leaks. Personnel must stay out of potential hazardous areas while testing and using.
- 4.0 HOSE AND FITTING MAINTENANCE INSTRUCTIONS**
- 4.1 Visual Inspection Hose/Fitting:** Any of the following conditions require immediate shut down and replacement of the hose assembly
- Fitting slippage on hose.
 - Damaged, cut or abraded cover (any reinforcement exposed).
 - Hard, stiff, heat cracked, or charred hose.
 - Cracked, damaged, or badly corroded fittings.
 - Leaks at fitting or in hose.
 - Kinked, crushed, flattened or twisted hose.
 - Blistered, soft, degraded, or loose cover.
- 4.2 Visual Inspection All Other:** The following items must be tightened, repaired or replaced as required:
- Leaking port conditions.
 - Remove excess dirt buildup.
 - Clamps, guards, shields.
 - System fluid level, fluid type and any air entrapment.
- 4.3 Functional Test:** Operate the system at maximum operating pressure and check for possible malfunctions and freedom from leaks. Personnel must avoid potential hazardous areas while testing and using.
- 4.4 Replacement Intervals:** Specific replacement intervals must be considered based on previous service life, government or industry recommendations, or when failure could result in unacceptable downtime, damage, or injury risk. See instructions 1.2.

Media	GPH	Media	GPH
Acetaldehyde	P	Gas (Oil) (2)	G
Acetic Acid	G	Gas (Natural) (4)	(2)
Acetone	P	Gasoline (Aromatic and Non-Aromatic) (2)	L
Acetylene	(2)	Glue	(3)
Air (4)	G	Glycerine	G
Alcohols (Menthanol-Ethanol) (6)	G	Glycol to 150°F	G
Ammonium Chloride	G	Greases	G
Ammonium Hydroxide	L	Heptachlor (Insecticide)	—
Anhydrous Ammonia (2)	P	Hexane (2)	L
Aniline	L	Houghto Safe—600 Series	
Animal Oils (6)	G	(Hydraulic Fluid/Water Glycol)	G
Aromatic Hydrocarbons	P	Houghto Safe—1000 Series	
Asphalt	G	(Phosphate Ester Base)	G
Baygon (Insecticide)	—	Hydraulic Fluid—Petroleum Base	G
Beer	G	Hydraulic Fluid—Phosphate Ester Base	G
Benzene	L	Hydraulic Fluid—Water Glycol Base	G
Brake Fluid (DOT #3)	P	Hydraulic Oil	L
Butane (2) (4)	G	Hydrochloric Acid	—
Butter (6)	G	Hydrofluoric Acid	L
Calcium Chloride Solutions	L	Hydrogen Gas (2) (4)	G
Carbon Dioxide (4)	G	Hydrolube	
Carbon Monoxide (4)	G	(Hydraulic Fluid/Water Glycol Base)	G
Carbon Tetrachloride	L	IRUS 902	
Castor Oil	G	(Hydraulic Fluid/Water-Oil Emulsion)	G
Chlorinated Hydrocarbon Base Fluids	P	Isocyanates	—
Chlorinated Petroleum Oil	—	Isooctane (2)	L
Chlorinated Solvents	L	Isopropyl Alcohol	—
Chlorine Gas, Dry	G	Kerosene (2)	L
Chlordane (Insecticide)	—	Ketones	P
Chloroform	P	Lacquer Solvents	P
Chromic Acid	G	Lactic Acid	G
Citric Acid Solutions	G	Lime	G
Crude Petroleum Oil	G	Lindol	
Cyclohexane (2)	—	(Hydraulic Fluid/Phosphate Esters)	—
Cygon (Insecticide)	—	Linseed Oil	G
Diazinon (Insecticide)	—	LP-Gas	(2)
Diesel Fuel (2)	L	Lubricating Oils (Diester Base)	—
Diester Oils	—	Lubricating Oils (Petroleum Base)	G
Enamels	L	Malathion (Insecticide)	—
Ethanol (6)	L	Magnesium Hydroxide	G
Ethers	L	Magnesium Salts	G
Ethylene Glycol (to 150°F)	G	Mercury	G
Ethylene Oxide	—	Meropa Oil (Sulphur Base)	—
Fatty Acid	G	Methane	(2)
Formaldehyde	G	Methanol	P
Formic Acid	G	Methoxychlor (Insecticide)	—
Freon 12 (5)	G	Methyl Alcohol	P
Freon 22 (5)	G	Methylene Chloride	L
Fruit Juices (6)	G	Methyl Ethyl Keytone (MEK)	P
Fuel Oil (2)	L	Methyl Ethyl Keytone Peroxide (MEKP)	—

Ratings Code (1)

- G — Good to excellent. Little or no swelling, tensile or surface changes. Preferred choice.
 L — Marginal or conditional. Noticeable effects but not necessarily indicating lack of serviceability. Further testing suggested for specific application. Very long term effects such as stiffening or potential for crazing should be evaluated.
 P — Poor or unsatisfactory. Not recommended without extensive and realistic testing.
 — — Not tested.

NOTE: For Footnotes (1), (2), (3), (4), (5), (6) & (7), See Page J12.



Media	GPH	Media	GPH
Methyl Isobutyl Keytone (MIBK)	P	Silicone Oil	—
Milk (6)	G	Skydrol 500, 7000	P
Mineral Oil	G	Soap Solutions	G
Mineral Spirits	P	Soda Water (6)	G
Motor Oils	G	Sodium Borate	G
Naphtha	P	Sodium Carbonate	(3)
Natural Gas (4)	(2)	Sodium Chloride Solutions	G
Nitric Acid	G	Sodium Hydroxide, 50%	L
Nitrobenzene	P	Sodium Hypochlorite	L
Nitrogen Gas (4)(5)	G	Steam	P
Oil	G	Stoddard Solvent	L
Oil of Turpentine	G	Straight Synthetic Oils (Phosphate Ester and Phosphate Ester Base)	P
Oleic Acid	L	Chlorinated Hydrocarbon Base	—
OS 45 Hydraulic Fluid (Silicate Ester Base)	—	Sulphur	G
Oxygen Gas (4) (5) (6)	G	Sulphur Hexafluoride Gas (4) (5)	—
Ozone	G	Sulphuric Acid	P
Paint Solvents (Oil Base) (7)	P	Toluene	P
Paints (Oil Base) (7)	P	Toluol	P
Pentane (2)	L	Transmission Fluid	—
Perchloric Acid	L	Trichloroethylene	L
Perchloroethylene	L	Trisodium Phosphate Solutions	G
Petroleum Ether	P	Turpentine	G
Petroleum Oils	G	Ucon (Hydraulic Fluid — Water Glycol Base)	G
Phenols	L	Varnish	P
Phosphate Esters (Above 150°F)	P	Vinegar (6)	G
Phosphate Esters (to 150°F)	P	Water (to 135°F) (6)	G
Polyol Esters	P	Water (Above 135°F) (6)	L
Potassium Hydroxide, 50%	L	Water Glycols (to 135°F)	G
Propane (4) (5)	(2)	Water Glycols (Above 135°F)	G
Propylene Glycol	L	Water in Oil Emulsions (to 135°F)	G
Pydraul F-9, 150,160 (to 135°)	P	Water in Oil Emulsions (Above 135°F)	L
Pydraul 312 C, 625 (to 135°F)	P	Whiskey (6)	G
Quintolubric 822 Fluid	—	Wood Oil	G
Salt Water	(3)	Xylene	P
Sevin (Insecticide in Water)	—	Zinc Chloride	G
Silicone Grease	—		

Ratings Code (1)

G — Good to excellent. Little or no swelling, tensile or surface changes. Preferred choice.

L — Marginal or conditional. Noticeable effects but not necessarily indicating lack of serviceability. Further testing suggested for specific application. Very long term effects such as stiffening or potential for crazing should be evaluated.

P — Poor or unsatisfactory. Not recommended without extensive and realistic testing.

— — Not tested.

- The Chemical Compatibility Guides are simplified rating tabulations based on immersion tests at 75°F. Higher temperatures tend to reduce ratings. Since final selection depends on pressure, media and ambient temperature and other factors not known to Parker Hannifin Corporation, no performance guarantee is expressed or implied. Ratings do not imply compliance with specialized codes such as FDA, NSF, AGA or UL and do not cover possible fluid discoloration, taste or odor effects. For conveying foodstuffs use FDA sanctioned materials, and for potable water use NSF approved materials. For chemicals not listed, or for advice on particular applications, please consult the supplier.
- Hose applications for these fluids must take into account legal and insurance regulations. This does not imply AGA or UL compliance.
- Satisfactory at some concentrations and temperatures, unsatisfactory in others.
- For high pressure gases, the cover should be pinpricked and the pressure must not be released quickly. Chain or restrain the hose to prevent personal injury in the event of damage or failure.
- Chemical compatibility does not imply low permeation rates. Consult the supplier for a recommendation for your specific requirements.
- Does not imply NSF or FDA compliance.
- Chemical compatibility does not imply acceptability for use in airless paintspray applications. These applications require a special conductive hose.



Notes

F



Section F



Prestomatic Fittings.....	F108-F116	Polyethylene Tubing.....	F193-F194
Poly-Tite Fittings.....	F117-F125	Nylon Tubing.....	F195-F196
Prestolok.....	F126-F148	Polyurethane Tubing.....	F197
Dubl-Barb®.....	F149-F153	Burst Pressure / Temperature Charts.....	F198-F199
Hose Barb.....	F154-F157	Chemical Compatibility Guide	
Global Connectors.....	F158-F165	Brass.....	F200-F201
TrueSeal™.....	F166-F176	Thermoplastic.....	F202-F203
Pipe Fittings.....	F177-F183	Tubing.....	F204-F205
Brass Metric Adapters.....	F184-F188	Approvals.....	F206
FS Hose & Fittings.....	F189-F192	Technical Information.....	F207-F208

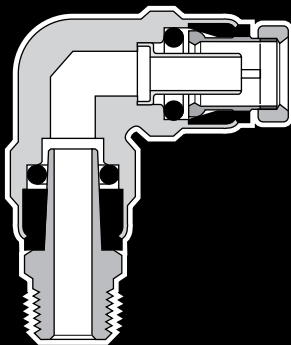

Prestomatic Air Brake Push-In Fittings

Advantages

Patented design of sizes 5/32" and above meet SAE J2494 and D.O.T. FMVSS 571.106 air brake performance specifications.. No special tools are needed to assemble. Just bottom the tubing in the fitting body for a positive seal. Stainless steel tube support in sizes 1/4" and above assures maximum flow and performance requirements of SAE J1131. 1/8" Prestomatic[†] is designed for use in pressure protected air accessory lines that are isolated from the air brake system.

Application

Use with Parker Parflex SAE J844 type A & B nylon tubing. Designed for all D.O.T. truck and trailer applications. Consult the factory with any questions regarding special product applications. Prior to use, all applications should be carefully tested through the range of conditions which may be encountered.

Features

1. All brass body.
2. Stainless steel tube support assures maximum flow and performance characteristics.
3. Elbows and tees are available in swivel or rigid dryseal pipe threads. Swivels are designed for alignment purposes only.
4. Lubricated O-Ring Seal (Buna N) insures a quick, easy and positive seal.
5. Innovative Collet design insures positive grip on tubing.
6. Release Button offers quick and easy disconnections.

Technical Data

- Working pressure from vacuum to 250 PSI.
- Working temperature from -40° F to +200°F
Note: See tubing manufacturer's recommendations for pressure and temperature limitations.
- Buna N (Nitrile) O-Rings.

Nomenclature

Part numbers are constructed from symbols that identify the style and size of the fitting. The first series of numbers and letters identify the style and type of fitting. The Prestomatic series 1/4" and above has a stainless steel tube support and is designated with a "PMT" suffix. The Prestomatic series in sizes 1/8", 5/32", and 3/16" does not have a tube support and is designated with a "PM" suffix.

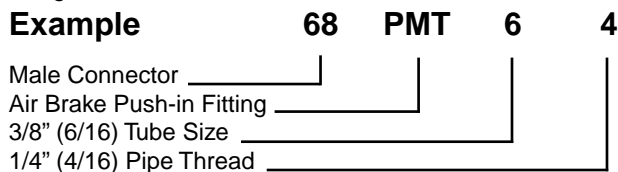

Special Fittings

Fitting configurations and/or sizes other than those shown in the catalog can be furnished. It is suggested that a print or sketch be submitted with the inquiry. Price and delivery for non-stock items furnished on request for specified quantities.

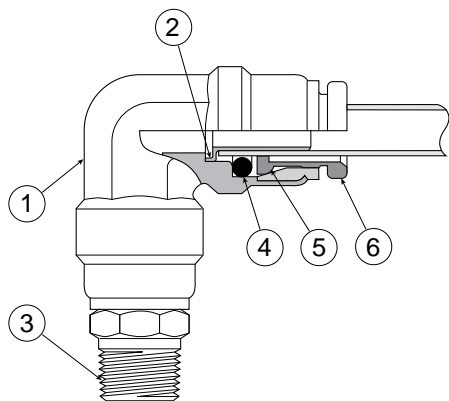

[†] U.S. Patent No. 5,683,120



Assembly Instructions

1. Cut tubing squarely—maximum of 15° angle allowable.
 - Use of Parker tube cutter PTC-001 is recommended.
2. Check that port or mating part is clean and free of debris.
3. Insert tubing into fitting until it bottoms.
 - Push twice to verify that tubing is inserted past collet and O-Ring.
4. Pull on tubing to verify it is fully inserted.
5. To disassemble, simply press release button, hold against body, and pull tubing out of fitting.

Note: In order to pass hot pull requirements of SAE J1131 a stainless steel tube support must be present in the end of the fitting before final fitting assembly.

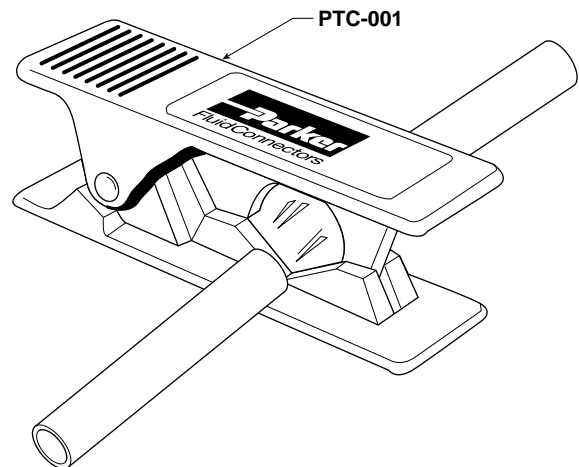

Tubing Nomenclature

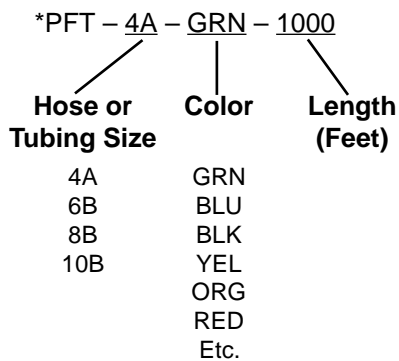

* Order from Parker Parflex Division

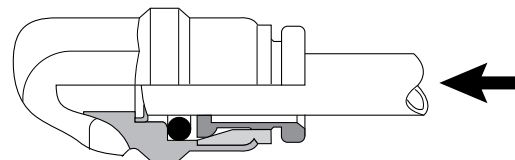

Insert Tubing until it Bottoms

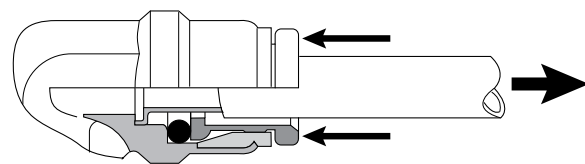

Depress Button to remove Tubing

† U.S. Patent No. 5,683,120



Prestomatic† Retaining Ring Bulkhead Unions

Prestomatic† retaining ring bulkhead unions feature a unique design that provides the user with an economical method to install and assemble a union connection through a bulkhead. The retaining ring bulkhead unions feature a smaller envelope size than standard bulkhead union connectors and do not require a wrench to mount or assemble in cramped areas.

The external seal feature provides a moisture barrier and can also prevent external contamination from entering into an enclosed area.

To install, simply support the bulkhead union from behind and apply the external seal. Then push the external retainer against the external seal with an assembly tool and you have a reliable bulkhead connection in a confined area.

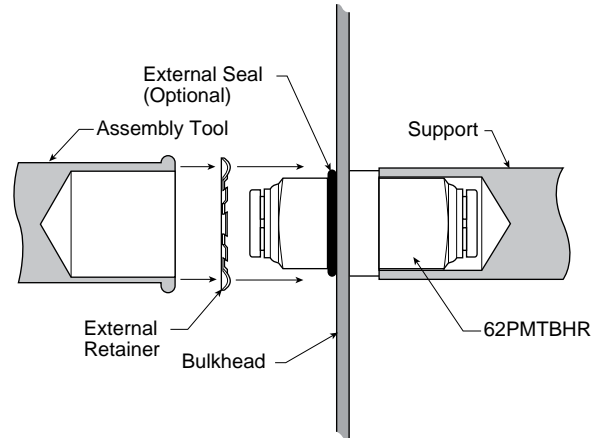

62PMTBHR Retaining Ring Bulkhead

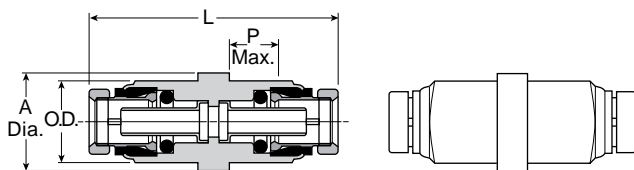

Part No.	Tube Size	O.D.	Rec. Hole Size	P Max.	L	A Dia.
62PMTBHR-4	1/4	0.500	0.512	0.26	1.53	0.625
62PMTBHR-6	3/8	0.750	0.762	0.36	1.92	0.875
62PMTBHR-8	1/2	0.875	0.887	0.43	2.15	1.000
62PMTBHR-10	5/8	1.000	1.012	0.62	2.54	1.250

ES* External Seal

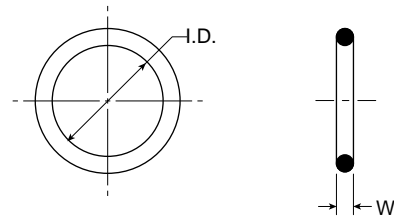

Part No.	Tube Size	Bulkhead Union O.D.	A Dia.	W
ES-50	1/4	0.500	0.489	0.07
ES-75	3/8	0.750	0.739	0.07
ES-87	1/2	0.875	0.864	0.07

*Material is Nitrite (Buna N), 70 Durometer

ERHD* External Retainer

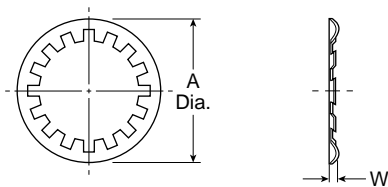

Part No.	Tube Size	Bulkhead Union O.D.	A Dia.	W
ERHD-50	1/4	0.500	0.83	0.05
ERHD-75	3/8	0.750	1.08	0.05
ERHD-87	1/2	0.875	1.20	0.05
ERHD-100	5/8	1.000	1.33	0.05

*Material Carbon Spring Steel

62PM Union

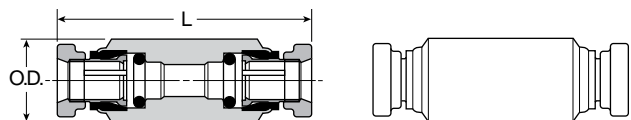

Part No.	Tube Size	L	O.D.
62PM-2	1/8	1.60	0.406
62PM-5/32	5/32	1.60	0.406
62PM-3	3/16	1.35	0.440

*Material is Nitrite (Buna N), 70 Durometer

† U.S. Patent No. 5,683,120

62PMT Union

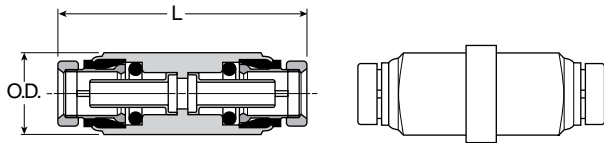

Part No.	Tube Size	L	O.D.
62PMT-4	1/4	1.48	0.50
62PMT-4-2	1/4 - 1/8	1.48	0.50
62PMT-6	3/8	1.87	0.75
62PMT-6-4	3/8 - 1/4	1.68	0.75
62PMT-8	1/2	2.03	0.88
62PMT-10	5/8	2.42	1.00

62PMTBH Bulkhead Union

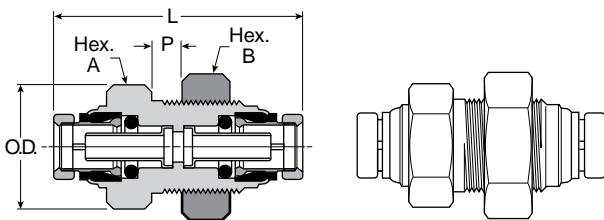

Part No.	Tube Size	O.D.	L	P Max.	A Hex.	B Hex.	Bulkhead Hole Dia.
62PMTBH-4	1/4	0.56	1.69	0.25	11/16	3/4	9/16
62PMTBH-6	3/8	0.88	1.93	0.44	1-1/16	1-1/16	7/8
62PMTBH-8	1/2	1.00	2.02	0.58	1-1/4	1-1/4	1
62PMTBH-10	5/8	1.12	2.92	0.81	1-1/4	1-3/8	1-1/8

66PMT Female Connector

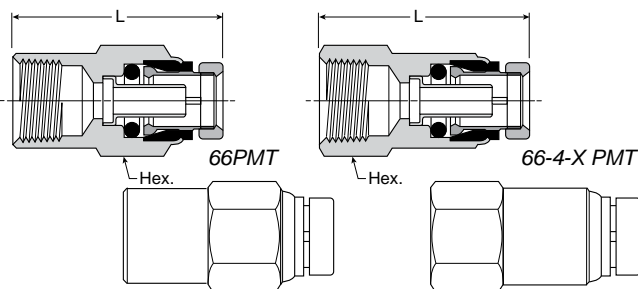

Part No.	Tube Size	Pipe Thread	L	Hex.
66PMT-4-2	1/4	1/8	1.22	9/16
66PMT-4-4	1/4	1/4	1.43	11/16
66PMT-6-2	3/8	1/8	1.37	3/4
66PMT-6-4	3/8	1/4	1.58	3/4
66PMT-6-6	3/8	3/8	1.62	13/16
66PMT-8-4	1/2	1/4	1.69	7/8
66PMT-8-6	1/2	3/8	1.68	7/8
66PMT-8-8	1/2	1/2	1.91	1

† U.S. Patent No. 5,683,120

66PMTBH Bulkhead Female Connector

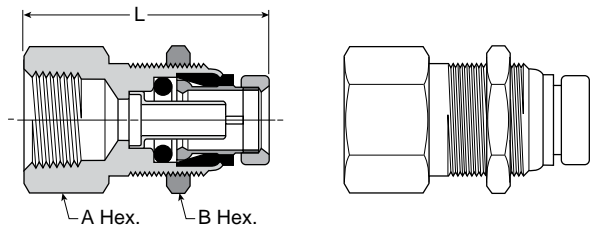

Part No.	Tube Size	Pipe Thread	L	A Hex.	B Hex.	Bulkhead Hole Dia.
66PMTBH-4-4	1/4	1/4	1.62	11/16	3/4	9/16
66PMTBH-6-6	3/8	3/8	1.87	1.06	1.06	7/8
66PMTBH-8-8	1/2	1/2	2.02	1-1/4	1-1/4	1

68PM Male Connector

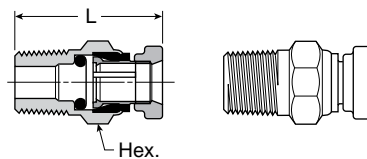

Part No.	Tube Size	Pipe Thread	L	Hex.
68PM-2-1	1/8	116	0.93	3/8
68PM-2-2	1/8	1/8	0.88	7/16
68PM-5/32-1	5/32	1/16	0.95	3/8
68PM-5/32-2	5/32	1/8	0.74	7/16
68PM-5/32-4	5/32	1/4	0.99	9/16
68PM-3-1	3/16	1/16	0.95	7/16
68PM-3-2	3/16	1/8	0.92	7/16
68PM-3-4	3/16	1/4	1.10	9/16

68PMT Male Connector

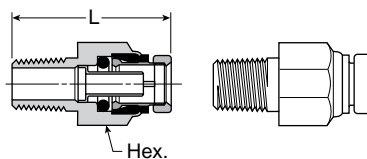

Part No.	Tube Size	Pipe Thread	L	Hex.
68PMT-4-2	1/4	1/8	1.06	1/2
68PMT-4-4	1/4	1/4	1.19	9/16
68PMT-4-6	1/4	3/8	1.27	3/4
68PMT-6-2	3/8	1/8	1.37	3/4
68PMT-6-4	3/8	1/4	1.43	3/4
68PMT-6-6	3/8	3/8	1.33	3/4
68PMT-6-8	3/8	1/2	1.38	7/8
68PMT-8-4	1/2	1/4	1.72	7/8
68PMT-8-6	1/2	3/8	1.52	7/8
68PMT-8-8	1/2	1/2	1.44	7/8
68PMT-10-6	5/8	3/8	1.88	1
68PMT-10-8	5/8	1/2	1.88	1
68PMT-12-8	3/4	1/2	2.03	1-3/16
68PMT-12-12	3/4	3/4	2.03	1-1/8



68PMT-X-M Male Connector to Metric Adapter

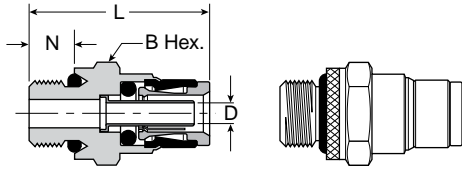

Part No.	Tube Size	Metric Thread	L	B Hex.	N
68PMT-4-M12	1/4	M12x1.5	1.19	11/16	0.29
68PMT-4-M16	1/4	M16x1.5	1.29	7/8	0.39
68PMT-6-M12	3/8	M12x1.5	1.40	3/4	0.29
68PMT-6-M16	3/8	M16x1.5	1.35	7/8	0.39
68PMT-6-M22	3/8	M22x1.5	1.23	1-1/16	0.40
68PMT-8-M12	1/2	M12x1.5	1.45	7/8	0.29
68PMT-8-M16	1/2	M16x1.5	1.52	7/8	0.39
68PMT-8-M22	1/2	M22x1.5	1.31	1-1/16	0.37
68PMT-10-M16	5/8	M16x1.5	1.78	1	0.39

68PMTBH Bulkhead Male Connector

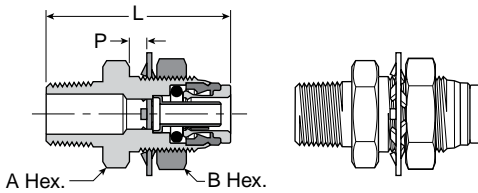

Part No.	Tube Size	Pipe Thread	L	P Max.	A Hex.	B Hex.	Bulkhead Hole Dia.
68PMTBH-6-8	3/8	1/2	2.37	0.33	1-1/4	1-1/4	1
68PMTBH-8-8	1/2	1/2	2.38	0.33	1-1/4	1-1/4	1

164PM Union Tee

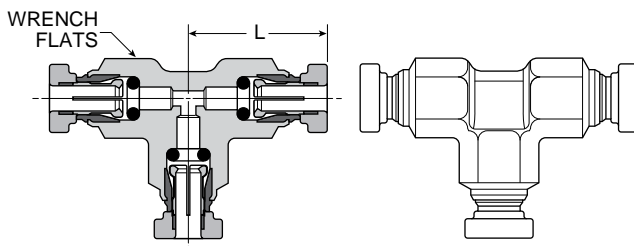

Part No.	Tube Size	L	Wrench Flats
164PM-2	1/8	0.81	0.42
164PM-5/32	5-32	0.71	0.42

164PMT Union Tee

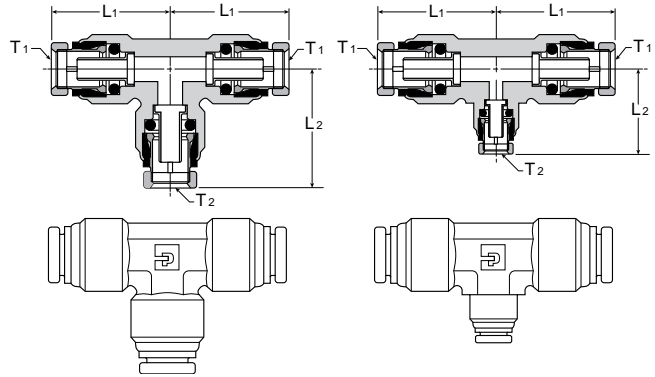

Part No.	Tube 1 Size	Tube 2 Size	L1	L2
164PMT-4	1/4	1/4	0.85	0.85
164PMT-6	3/8	3/8	1.21	1.21
164PMT-6-6-5/32	3/8	5/32	1.22	0.85
164PMT-6-6-4	3/8	1/4	1.21	0.93
164PMT-8	1/2	1/2	1.27	1.27
164PMT-10	5/8	5/8	1.63	1.62

165PMT Union Elbow

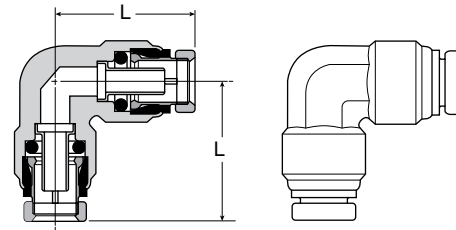

Part No.	Tube Size	L
165PMT-4	1/4	0.85
165PMT-6	3/8	1.11
165PMT-8	1/2	1.24
165PMT-10	5/8	1.57

165PMTBH Union Bulkhead Elbow

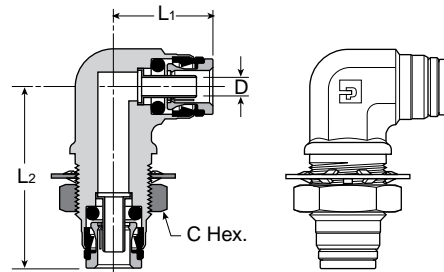

Part No.	Tube Size	L1	L2	C Hex.	Flow Dia. D	Bulkhead Hole Dia.
165PMTBH-6-8	1/2	1.29	2.45	1-1/4	0.34	1

† U.S. Patent No. 5,683,120

F



169PMNS Male Elbow Non-Swivel

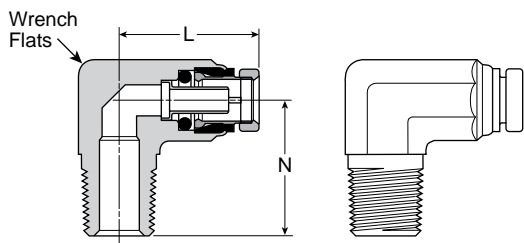

Part No.	Tube Size	Pipe Thread	L	N	Wrench Flats
169PMNS-2-2	1/8	1/8	0.86	0.68	3/8
169PMNS-5/3-2	5-32	1/8	0.88	0.68	3/8
169PMNS-3-2	3/16	1/8	0.75	0.67	3/8
169PMNS-3-4	3/16	1/4	0.74	0.93	1/2

169PMT Male Elbow Swivel 90°

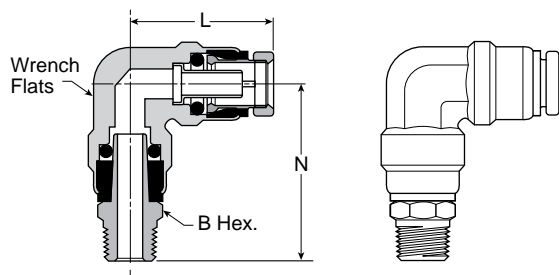

Part No.	Tube Size	Pipe Thread	B Hex.	L	N	Wrench Flats
169PMT-4-2	1/4	1/8	7/16	0.84	1.21	13/32
169PMT-4-4	1/4	1/4	9/16	0.84	1.43	13/32
169PMT-4-6	1/4	3/8	11/16	0.84	1.43	13/32
169PMT-6-2	3/8	1/8	9/16	1.11	1.41	9/16
169PMT-6-4	3/8	1/4	9/16	1.11	1.58	9/16
169PMT-6-6	3/8	3/8	11/16	1.11	1.58	9/16
169PMT-6-8	3/8	1/2	7/8	1.11	1.79	9/16
169PMT-8-4	1/2	1/4	5/8	1.27	1.73	11/16
169PMT-8-6	1/2	3/8	3/4	1.27	1.81	11/16
169PMT-8-8	1/2	1/2	7/8	1.27	1.96	11/16
169PMT-10-6	5/8	3/8	3/4	1.53	2.03	7/8
169PMT-10-8	5/8	1/2	7/8	1.53	2.18	7/8

169PMTBH Male Elbow Bulkhead

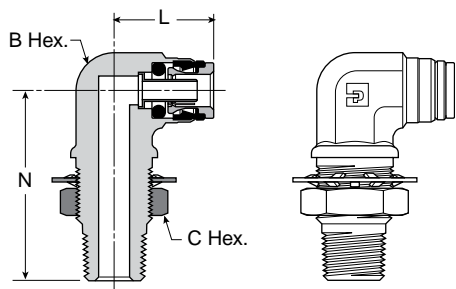

Part No.	Tube Size	Pipe Thread	L	N	B Hex.	C Hex.	Bulkhead Hole Dia.
169PMTBH-6-8	3/8	1/2	1.19	2.50	1-1/4	7/8	1
169PMTBH-8-8	1/2	1/2	1.29	2.50	1-1/4	7/8	1

† U.S. Patent No. 5,683,120

169PMTL Male Elbow Long Non-Swivel 90°

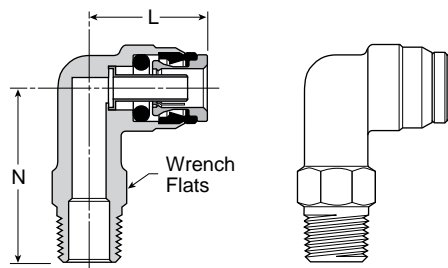

Part No.	Tube Size	Pipe Thread	L	N	Wrench Flats
169PMTL-6-4	3/8	1/4	1.06	1.63	9/16
169PMTL-6-6	3/8	3/8	1.19	2.50	7/8
169PMTL-6-8	3/8	1/2	1.19	2.50	7/8
169PMTL-8-8	1/2	3/8	1.22	2.50	7/8
169PMTL-10-8	5/8	3/8	1.46	2.50	7/8

169PMTNS Male Elbow Non-Swivel 90°

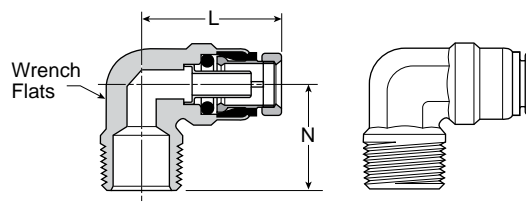

Part No.	Tube Size	Pipe Thread	L	N	Wrench Flats
169PMTNS-4-2	1/4	1/8	0.84	0.72	1/2
169PMTNS-4-4	1/4	1/4	0.84	0.90	1/2
169PMTNS-4-6	1/4	3/8	0.84	1.06	1/2
169PMTNS-6-2	3/8	1/8	1.05	0.75	9/16
169PMTNS-6-4	3/8	1/4	1.05	0.94	9/16
169PMTNS-6-6	3/8	3/8	1.05	0.94	3/4
169PMTNS-6-8	3/8	1/2	1.12	1.26	11/16
169PMTNS-8-4	1/2	1/4	1.17	1.06	11/16
169PMTNS-8-6	1/2	3/8	1.22	1.06	11/16
169PMTNS-8-8	1/2	1/2	1.22	1.26	11/16
169PMTNS-10-6	5/8	3/8	1.46	1.11	7/8
169PMTNS-10-8	5/8	1/2	1.46	1.32	7/8
169PMTNS-12-8	3/4	1/2	1.81	1.44	1



169PMTNS-X-M
Male Elbow Non-Swivel to Metric Adapter

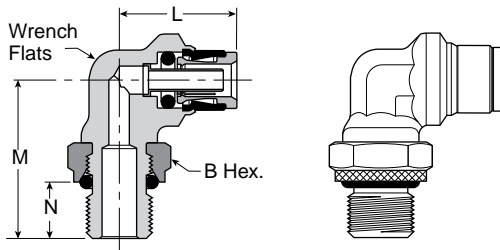

Part No.	Tube Size	Pipe Thread (mm)	Pipe			Wrench Flats (mm)	B Hex. (mm)
			L	M	N		
169PMTNS-4-M12	1/4	M12x1.5	0.84	1.11	0.37	10	17
169PMTNS-4-M16	1/4	M16x1.5	0.96	1.27	0.41	11	24
169PMTNS-4-M22	1/4	M22x1.5	1.09	1.53	0.41	16	30
169PMTNS-6-M12	3/8	M12x1.5	1.10	1.15	0.66	16	17
169PMTNS-6-M16	3/8	M16x1.5	1.23	1.27	0.41	19	24
169PMTNS-8-M12	1/2	M12x1.5	1.21	1.31	0.37	16	17
169PMTNS-8-M16	1/2	M16x1.5	1.26	1.34	0.41	16	24
169PMTNS-8-M22	1/2	M22x1.5	1.26	1.59	0.41	19	30
169PMTNS-12-M22	3/4	M22x1.5	1.77	1.59	0.41	27	30

170PMTNS Female Elbow Non-Swivel 90°

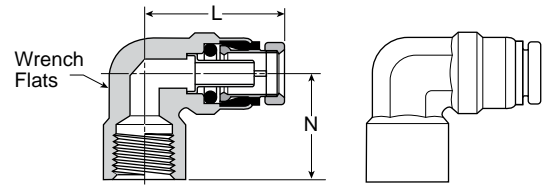

Part No.	Tube Size	Pipe Thread	L	N	Wrench Flats
170PMTNS-4-2	1/4	1/8	.84	0.56	11/16
170PMTNS-4-4	1/4	1/4	1.00	0.67	11/16
170PMTNS-6-2	3/8	1/8	1.12	0.64	9/16
170PMTNS-6-4	3/8	1/4	1.25	1.00	11/16
170PMTNS-6-6	3/8	3/8	1.25	1.00	13/16
170PMTNS-8-4	1/2	1/4	1.25	0.75	11/16
170PMTNS-8-6	1/2	3/8	1.32	0.88	11/16
170PMTNS-8-8	1/2	1/2	1.70	0.98	1

169PMTR Male Elbow Positional Swivel 90°

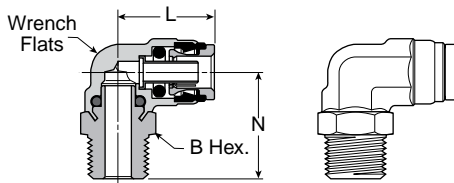

Part No.	Tube Size	Pipe Thread	B Hex.	L	N	Wrench Flats
169PMTR-4-4	1/4	1/4	9/16	0.84	1.13	1/2
169PMTR-6-6	3/8	3/8	3/4	1.12	1.19	9/16
169PMTR-10-8	5/8	1/2	7/8	1.54	1.50	7/8

171PMT Male Run Tee Swivel 90°

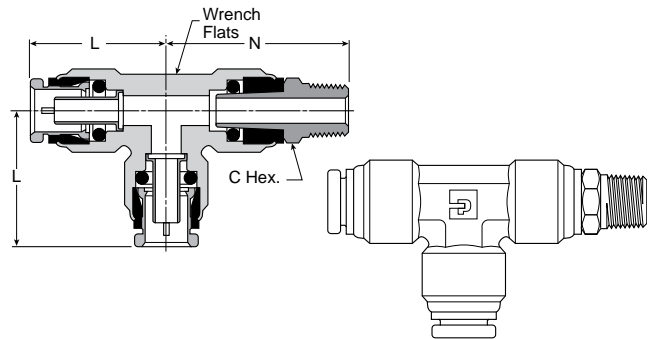

Part No.	Tube Size	Pipe Thread	L	N	C Hex.	Wrench Flats
171PMT-4-2	1/4	1/8	0.85	1.25	7/16	1/2
171PMT-4-4	1/4	1/4	0.85	1.48	9/16	1/2
171PMT-6-2	1/4	3/8	0.85	1.43	11/16	1/2
171PMT-6-4	3/8	1/4	1.21	1.83	9/16	5/8
171PMT-6-6	3/8	3/8	1.21	1.83	11/16	5/8
171PMT-8-4	1/2	1/4	1.27	1.74	5/8	7/8
171PMT-8-6	1/2	3/8	1.27	1.83	3/4	7/8
171PMT-8-8	1/2	1/2	1.27	1.99	7/8	7/8

170PMT Female Elbow Swivel 90°

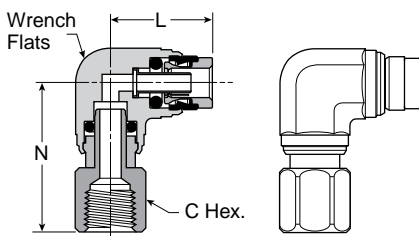

Part No.	Tube Size	Pipe Thread	L	N	C Hex.	Wrench Flats
170PMT-4-2	1/4	1/8-27	0.84	1.18	1/2	1/2

† U.S. Patent No. 5,683,120

F



171PMTNS Male Run Tee Non-Swivel 90°

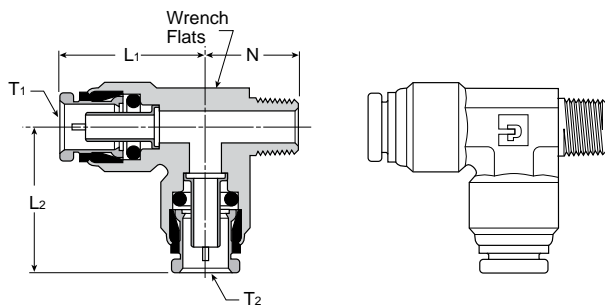

Part No.	Tube 1 Size	Tube 2 Size	Pipe Thread	L1	L2	N	Wrench Flats
171PMTNS-4-2	1/4	1/4	1/8	0.91	0.91	0.77	15/32
171PMTNS-4-4	1/4	1/4	1/4	0.91	0.91	0.94	15/32
171PMTNS-4-6-4	1/4	3/8	1/4	0.93	1.21	0.97	5/8
171PMTNS-6-4	3/8	3/8	1/4	1.21	1.21	0.97	5/8
171PMTNS-6-4-4	3/8	1/4	1/4	1.21	0.93	0.97	5/8
171PMTNS-6-4-6	3/8	1/4	3/8	1.22	0.97	0.93	5/8
171PMTNS-6-6	3/8	3/8	3/8	1.21	1.21	0.97	5/8
171PMTNS-6-8	3/8	3/8	1/2	1.17	1.17	1.26	5/8
171PMTNS-8-4	1/2	1/2	1/4	1.28	1.28	1.06	7/8

172PMTNS Male Branch Tee Non-Swivel

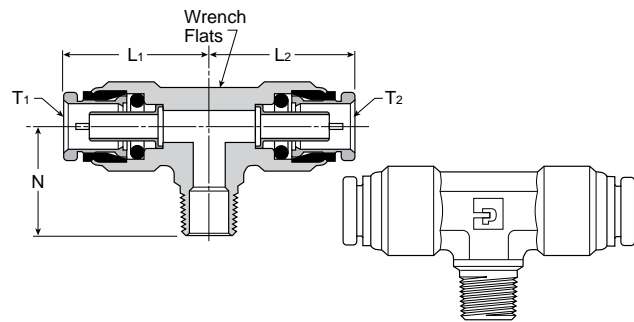

Part No.	Tube 1 Size	Tube 2 Size	Pipe Thread	L1	L2	N	Wrench Flats
172PMTNS-4-2	1/4	1/4	1/8	0.91	0.91	0.78	1/2
172PMTNS-6-4	3/8	3/8	1/4	1.21	1.21	0.97	5/8
172PMTNS-6-4-4	3/8	1/4	1/4	1.21	0.93	0.97	5/8
172PMTNS-6-6	3/8	3/8	3/8	1.21	1.21	0.97	5/8
172PMTNS-6-8	3/8	3/8	1/2	1.17	1.17	1.26	7/8
172PMTNS-8-6	1/2	1/2	3/8	1.28	1.28	1.06	7/8
172PMTNS-8-6-8	1/2	3/8	1/2	1.25	1.25	1.25	7/8
172PMTNS-8-8	1/2	1/2	1/2	1.34	1.34	1.25	7/8

172PMT Male Branch Tee Swivel

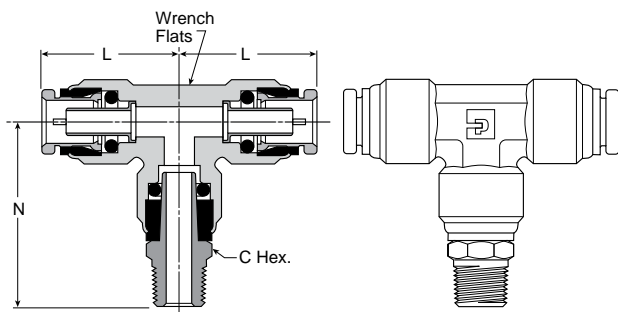

Part No.	Tube Size	Pipe Thread	L	N	C Hex.	Wrench Flats
172PMT-4-2	1/4	1/8	0.85	1.25	7/16	1/2
172PMT-4-4	1/4	1/4	0.85	1.43	9/16	1/2
172PMT-6-2	3/8	1/8	1.22	1.66	9/16	5/8
172PMT-6-4	3/8	1/4	1.22	1.83	5/8	5/8
172PMT-6-6	3/8	3/8	1.22	1.83	3/4	5/8
172PMT-8-4	1/2	1/4	1.27	1.73	5/8	7/8
172PMT-8-6	1/2	3/8	1.27	1.79	3/4	7/8
172PMT-8-8	1/2	1/2	1.27	1.97	7/8	7/8

179PMT Male Elbow Swivel 45°

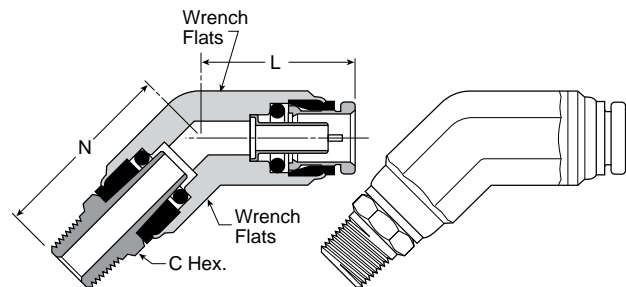

Part No.	Tube Size	Pipe Thread	L	N	C Hex.	Wrench Flats
179PMT-4-2	1/4	1/8	0.79	1.16	7/16	9/16
179PMT-4-4	1/4	1/4	0.89	1.46	9/16	9/16
179PMT-6-2	3/8	1/8	0.99	1.44	5/8	3/4
179PMT-6-4	3/8	1/4	0.99	1.61	5/8	3/4
179PMT-6-6	3/8	3/8	0.99	1.61	5/8	3/4
179PMT-8-4	1/2	1/4	1.20	1.70	5/8	7/8
179PMT-8-6	1/2	3/8	1.20	1.78	3/4	7/8
179PMT-8-8	1/2	1/2	1.20	1.93	7/8	7/8

[†] U.S. Patent No. 5,683,120



179PMTNS Male Elbow Non-Swivel 45°

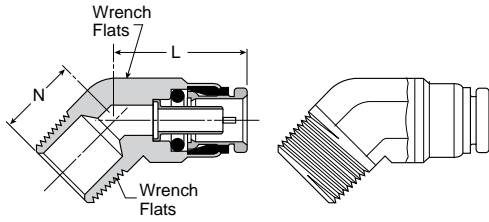

Part No.	Tube Size	Pipe Thread	L	N	Wrench Flats
179PMTNS-4-2	1/4	1/8	0.80	0.56	9/16
179PMTNS-4-4	1/4	1/4	0.80	0.75	9/16
179PMTNS-6-2	3/8	1/8	0.99	0.55	3/4
179PMTNS-6-4	3/8	1/4	0.99	0.73	3/4
179PMTNS-6-6	3/8	3/8	0.99	0.73	3/4
179PMTNS-8-4	1/2	1/4	1.28	0.81	13/16
179PMTNS-8-6	1/2	3/8	1.28	0.81	13/16
179PMTNS-8-8	1/2	1/2	1.28	1.06	13/16
179PMTNS-10-6	5/8	3/8	1.22	0.88	1-1/16
179PMTNS-10-8	5/8	1/2	1.22	1.00	1-1/16
179PMTNS-12-8	3/4	1/2	1.41	1.25	1-1/16

189PMTR Dual Port 90° Male Elbow Positional

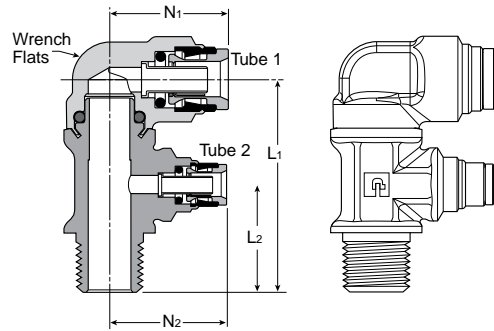

Part No.	Tube 1 Size	Tube 2 Size	Pipe Thread	L1	L2	N1	N2	Wrench Flats
189PMTR-6-4-6	3/8	1/4	3/8	2.12	1.05	1.21	1.19	11/16
189PMTR-6-6-4	3/8	3/8	1/4	2.06	0.98	1.12	1.20	9/16
189PMTR-6-6-6	3/8	3/8	3/8	2.06	0.98	1.12	1.20	9/16
189PMTR-10-6-6	5/8	1/4	3/8	2.18	1.05	1.54	1.19	7/8
189PMTR-10-6-8	5/8	3/8	3/8	2.31	1.12	1.54	1.18	7/8

179PMTR Male Elbow Positional Swivel 45°

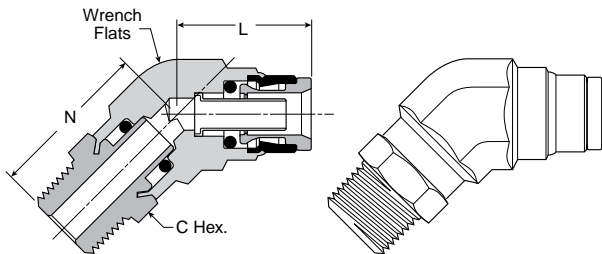

Part No.	Tube Size	Pipe Thread	L	N	C Hex.	Wrench Flats
179PMTR-4-4	1/4	1/4	0.79	1.18	9/16	9/16
179PMTR-8-8	1/2	1/2	1.17	1.35	7/8	7/8

639PM / 639PMT Push-To-Connect Fitting Plug

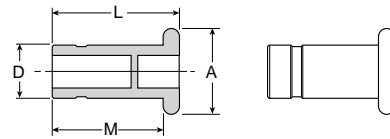

Part No.	Tube Size	L	M	A	D
639PM-5/32BL	5/32	1.09	1.00	0.39	0.156
639PMT-4	1/4	1.14	0.96	0.48	0.250
639PMT-6	3/8	1.33	1.15	0.67	0.375
639PMT-8	1/2	1.33	1.15	0.81	0.500

Specify color when ordering Black (BL) or Blue (BU), example 639PMT-4BU
Note: use appropriate PM / PMT style connection as determined by part number.

† U.S. Patent No. 5,683,120



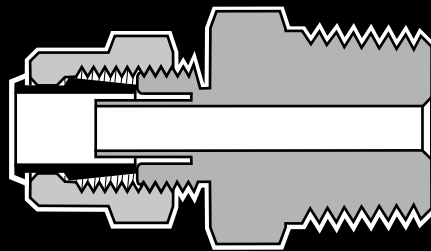

Poly-Tite Fittings

Advantages

A compact brass compression fitting designed to speed any installation. Body, nut and sleeve are furnished preassembled, ready for installation. An exclusive acetal copolymer sleeve holds plastic tubing where it belongs, even when the system pressure exceeds the tubing burst point. P fitting sleeves have superior resilience to resist creeping and stress caused from compression. The black acetal copolymer sleeve also resists ultra-violet ray attack and has excellent dimensional stability. P fitting nuts will rotate around the sleeve as it tightens to prevent twisting and weakening of the plastic tubing. P fittings can be assembled and disassembled repeatedly.

Materials

Bodies and Nuts: CA377, CA360, CA345, 316 Stainless Steel
 Plastic Sleeves: Acetal Copolymer
 O-rings: Buna N on chrome plated couplings, fluorocarbon on stainless steel couplings.

Applications

Use with Parker or other high-quality thermoplastic tubing for pneumatic instrumentation circuits, lubricant and coolant lines, and applications with other gases and liquids. For use with soft metal tubing and nylon thermoplastic tubing, use brass sleeve and nut assembly 61PB.

Working Pressure and Temperature Ranges

Up to 150 PSI from 0° to 150°F with thermoplastic tubing.
 Up to 300 PSI from 0° to 175°F with soft metal tubing.

Assembly Instructions

Polyethylene, polypropylene and vinyl tubing:

1. Cut tubing squarely – maximum of 15° angle allowable.
2. Check that port or mating part is clean and free of debris.
3. Insert tube end until it bottoms in the fitting and tighten knurl / hex nut finger tight – plus one wrench turn.

Copper, aluminum and nylon tubing:

Brass sleeves are recommended. Insert tube until it bottoms in the P fitting and tighten one wrench turn past finger-tight.

Maximum allowable metal tube wall thickness for use with P fittings: 1/8", 3/16", O.D. — no limitation, 1/4" O.D. — .035" 5/16", 3/8", 1/2" O.D. — .049".

Nomenclature

Part numbers are constructed from symbols that identify the style and size of the fitting. The first series of numbers and letters identifies the style and type fitting. The second series of numbers describes the size.

Example:

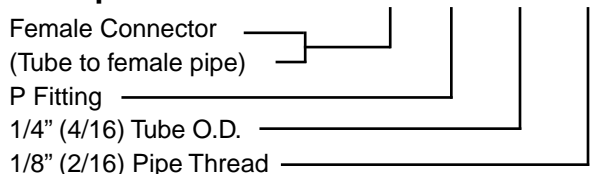

Sizes

Tube sizes are determined by the number of sixteenths of an inch in the tube O.D.

Special Fittings

Fitting configurations and/or sizes other than those shown in the catalog can be furnished. It is suggested that a print or sketch be submitted with the inquiry.

Tube Support O.D.

Tube Size Inches	*D1 Tube Support O.D.
1/4	.168
5/16	.185
3/8	.248
1/2	.373

*Note: No tube support for sizes 1/8" and 3/16".

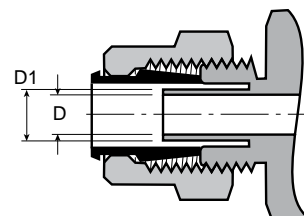

56PSG Spring Guard

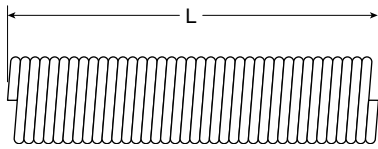

Part No.	Tube Size	L
56PSG-4	1/4	3.00
56PSG-5	5/16	3.00
56PSG-6	3/8	3.00

59P Plastic Cap



Part No.	Tube Size	A	L
59P-4	1/4	0.247	0.50
59P-5	5/16	0.307	0.53
59P-6	3/8	0.372	0.56
59P-8	1/2	0.497	0.63

60P Acetal Plastic Sleeve



Part No.	Tube Size	A	D	L
60P-4	1/4	0.334	0.261	0.338
60P-5	5/16	0.405	0.321	0.340
60P-6	3/8	0.465	0.381	0.367
60P-8	1/2	0.628	0.514	0.399

60PB Sleeve

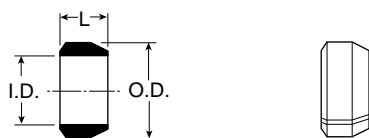

Part No.	L	O.D.	I.D.
60PB-2	0.187	0.265	0.130
60PB-3	0.187	0.322	0.192
60PB-4	0.187	0.336	0.255
60PB-5	0.187	0.400	0.318
60PB-6	0.218	0.460	0.382
60PB-8	0.250	0.620	0.507

61P Nut and Sleeve Assembly

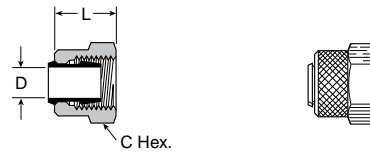

Part No.	Tube Size	Straight Thread	C Hex	D	L
61P-2*	1/8	5/16-24	3/8	0.130	0.34
61P-3*	3/16	3/8-24	7/16	0.192	0.37
61P-4	1/4	3/8-24	7/16	0.261	0.38
61P-5	5/16	7/16-24	1/2	0.321	0.34
61P-6	3/8	1/2-24	9/16	0.380	0.38
61P-8	1/2	11/16-20	3/4	0.514	0.44

*Brass Sleeve

61PB Nut and Sleeve Assembly

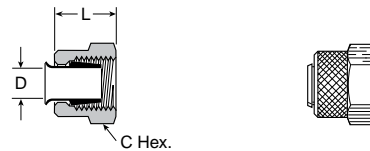

Part No.	Tube Size	Straight Thread	C Hex.	D	L
61PB-4	1/4	3/8-24	7/16	0.255	0.38
61PB-5	5/16	7/16-24	1/2	0.318	0.34
61PB-6	3/8	1/2-24	9/16	0.382	0.38
61PB-8	1/2	11/16-20	3/4	0.507	0.44

61PN Nut

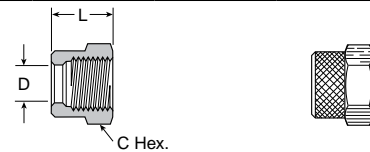

Part No.	Tube Size	Straight Thread	C Hex.	L
61PN-2	1/8	5/16-24	3/8	0.34
61PN-3	3/16	3/8-24	7/16	0.37
61PN-4	1/4	3/8-24	7/16	0.38
61PN-5	5/16	7/16-24	1/2	0.34
61PN-6	3/8	1/2-24	9/16	0.38
61PN-8	1/2	11/16-20	3/4	0.44

61PSGN Nut Only, for Use with Spring Guard

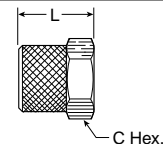

Part No.	Tube Size	L	C Hex.
61PSGN-4	1/4	0.625	0.437
61PSGN-5	5/16	0.625	0.500
61PSGN-6	3/8	0.656	0.562

F



62P Union

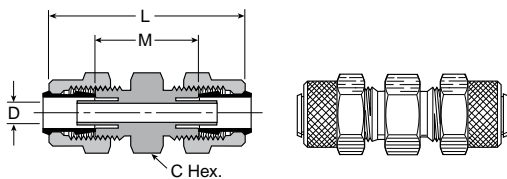

Part No.	Tube Size	Straight Thread	C Hex.	L	M	Flow Dia. D
62P-2*	1/8	5/16-24	5/16	1.08	0.64	0.094
62P-3*	3/16	3/8-24	3/8	1.16	0.73	0.125
62P-4	1/4	3/8-24	3/8	1.17	0.96	0.125
62P-5	5/16	7/16-24	7/16	1.16	0.96	0.144
62P-6	3/8	1/2-24	1/2	1.23	0.99	0.204
62P-8	1/2	11/16-20	11/16	1.47	1.24	0.323

*Brass Sleeve, No Tube Support

62P Union Reducer

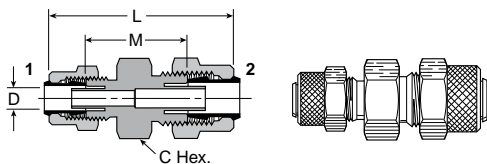

Part No.	1 Tube Size	2 Tube Size	1 Straight Thread	2 Straight Thread	C Hex.	L	M	Flow Dia. D
62P-6-4	1/4	3/8	3/8-24	1/2-24	1/2	1.22	0.99	0.125

62PBH Bulkhead Union

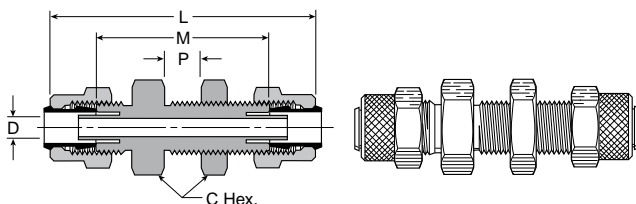

Part No.	Tube Size	Straight Thread	C Hex.	P Max.	L	M	Bulkhead Hole Dia.	Flow Dia. D
62PBH-4	1/4	3/8-24	9/16	0.38	1.75	1.53	3/8	0.125
62PBH-5	5/16	7/16-24	5/8	0.38	1.71	1.52	7/16	0.144
62PBH-6	3/8	1/2-24	11/16	0.47	1.89	1.65	1/2	0.204
62PBH-8	1/2	11/16-20	7/8	0.63	2.28	2.05	11/16	0.323

62PCA Union (Tube to Compress-Align Fitting)

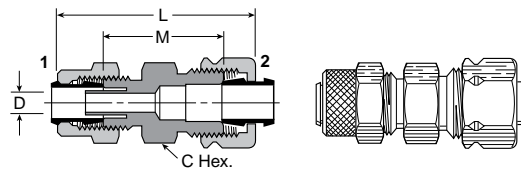

Part No.	1 Tube Size	2 Straight Thread	1 Straight Thread	C Hex.	L	M	Flow Dia. D
62PCA-4	1/4	3/8-24	7/16-24	7/16	1.25	0.89	0.125
62PCA-5	5/16	7/16-24	1/2-24	1/2	1.30	0.92	0.144
62PCA-6	3/8	1/2-24	9/16-24	9/16	1.37	0.98	0.204

62PCABH Bulkhead Union (Tube to Compress Align Fitting)

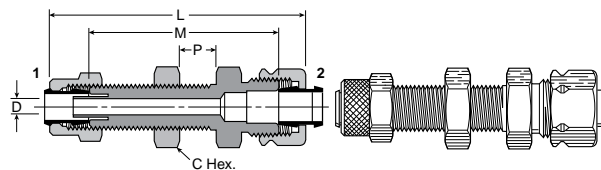

Part No.	1 Tube Size	2 Straight Thread	1 Straight Thread	C Hex.	P Max.	L	M	Bulkhead Hole Dia.	Flow Dia. D
62PCABH-4	1/4	3/8-24	7/16-24	9/16	0.38	1.81	1.45	3/8	0.125
62PCABH-6	3/8	1/2-24	9/16-24	11/16	0.47	2.03	1.64	1/2	0.204

62PTBH Bulkhead Union (Straight Through)

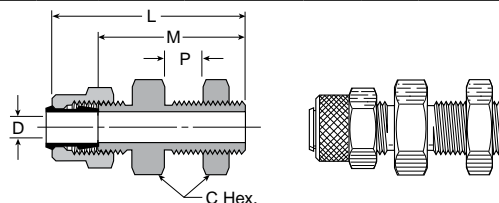

Part No.	Tube Size	Straight Thread	C Hex.	P Max.	L	M	Bulkhead Hole Dia.	Flow Dia. D
62PTBH-4	1/4	3/8-24	9/16	0.31	1.19	0.93	3/8	0.260
62PTBH-5	5/16	7/16-24	5/8	0.31	1.19	0.93	7/16	0.323
62PTBH-6	3/8	1/2-24	11/16	0.34	1.26	0.99	1/2	0.387

63PT Brass Insert

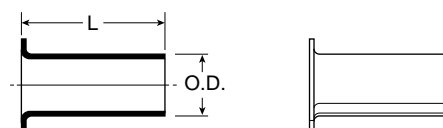

Part No.	Tube Size	L	O.D.
63PT-2-16	1/8	0.46	0.080
63PT-2-32	1/8	0.31	0.061
63PT-3-25	3/16	0.45	0.135
63PT-3-40	3/16	0.52	0.095



66P Female Connector

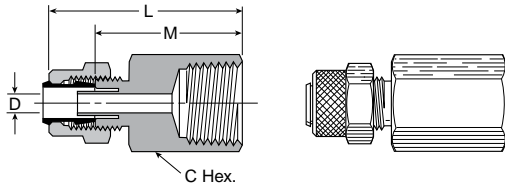

Part No.	Tube Size	Pipe Thread	Straight Thread	C Hex.	L	M	Flow Dia. D
66P-2-2*	1/8	1/8	5/16-24	9/16	0.97	0.75	0.094
66P-3-2*	3/16	1/8	3/8-24	9/16	1.00	0.78	0.125
66P-3-4*	3/16	1/4	3/8-24	11/16	1.18	0.96	0.125
66P-4-2	1/4	1/8	3/8-24	1/2	0.97	0.86	0.125
66P-4-4	1/4	1/4	3/8-24	5/8	1.18	1.07	0.125
66P-5-2	5/16	1/8	7/16-24	1/2	0.97	0.86	0.144
66P-6-4	3/8	1/4	1/2-24	5/8	1.18	1.07	0.204
66P-8-6	1/2	3/8	11/16-20	13/16	1.31	1.20	0.323

*Brass Sleeve, No Tube Support

68P Male Connector

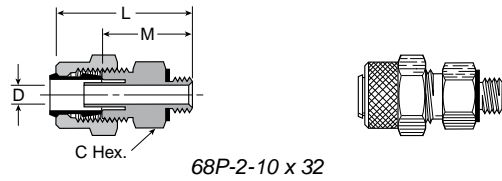
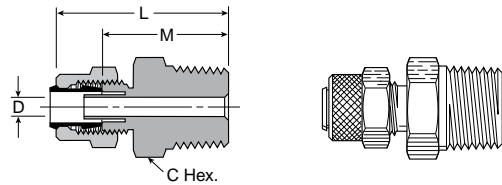

Part No.	Tube Size	Pipe Thread	Straight Thread	C Hex.	L	M	Flow Dia. D
68P-2-1*	1/8	1/16	5/16-24	11/32	1.00	0.78	0.094
68P-2-2*	1/8	1/8	5/16-24	7/16	0.99	0.77	0.094
68P-3-1	3/16	1/16	3/8-24	7/16	1.09	0.84	0.094
68P-3-2*	3/16	1/8	3/8-24	7/16	1.06	0.84	0.125
68P-3-4*	3/16	1/4	3/8-24	9/16	1.25	1.03	0.125
68P-4-1	1/4	1/16	3/8-24	3/8	1.06	0.95	0.125
68P-4-2	1/4	1/8	3/8-24	7/16	1.06	0.95	0.125
68P-4-4	1/4	1/4	3/8-24	9/16	1.25	1.14	0.125
68P-4-6	1/4	3/8	3/8-24	11/16	1.28	1.17	0.125
68P-5-2	5/16	1/8	7/16-24	7/16	1.05	0.95	0.144
68P-5-4	5/16	1/4	7/16-24	9/16	1.24	1.14	0.144
68P-6-2	3/8	1/8	1/2-24	1/2	1.10	0.98	0.204
68P-6-4	3/8	1/4	1/2-24	9/16	1.29	1.17	0.204
68P-6-6	3/8	3/8	1/2-24	11/16	1.29	1.17	0.204
68P-8-4	1/2	1/4	11/16-20	11/16	1.46	1.29	0.320
68P-8-6	1/2	3/8	11/16-20	11/16	1.37	1.29	0.323
68P-2-10 x 32*	1/8	10-32	5/16-24	3/8	0.86	0.64	0.094
68P-4-10 x 32	1/4	10-32	3/8-24	3/8	0.86	0.75	0.094

*Brass Sleeve, No Tube Support

97P Tube End Reducer

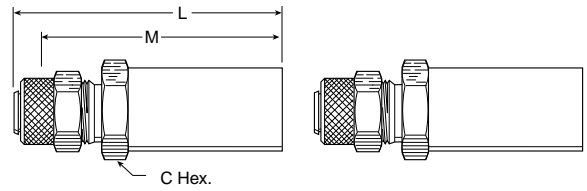

Part No.	Tube Size	C Hex.	L	M
97P-4-6	3/8 x 1/4	0.437	1.718	1.625
97P-6-8	1/2 x 3/8	0.562	1.875	1.781

391P Pipe Coupler Body (Chrome Plated)

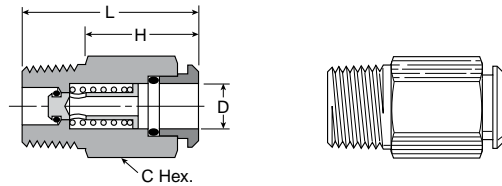

Part No.	Insert Dia.	Pipe Thread	C Hex.	H	L
391P-4-2	1/4	1/8	1/2	0.91	1.29
391P-4-4	1/4	1/4	9/16	0.73	1.29
391P-6-4	3/8	1/4	5/8	0.85	1.41

391PSS Pipe Coupler Body (Stainless Steel)

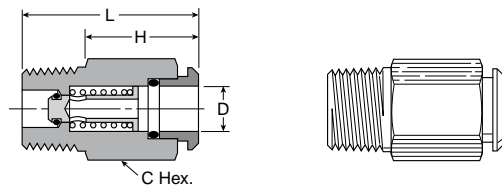

Part No.	Insert Dia.	Pipe Thread	C Hex.	H	L
391PSS-4-2	1/4	1/8	0.500	0.900	1.271
391PSS-4-4	1/4	1/4	0.562	0.710	1.271
391PSS-6-4	3/8	1/4	0.625	0.840	1.400

392P Bulkhead Coupler Body (Chrome Plated)

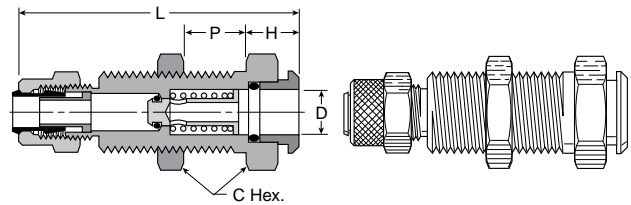

Part No.	Tube Size	Insert Dia.	Straight Thread	C Hex.	P Max.	H	L	Bulkhead Hole Dia.
392P-4-4	1/4	1/4	1/2-24	5/8	0.84	0.39	2.13	1/2
392P-6-6	3/8	3/8	11/16-24	13/16	0.93	0.37	2.01	11/16

F



392PSS Bulkhead Coupler Body (Stainless Steel)

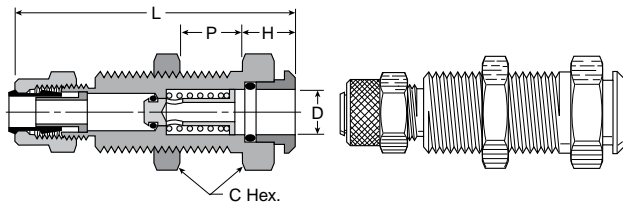

Part No.	D		Straight Thread	C Hex.	P Max.	H	L	Bulkhead Hole Dia.
	Tube Size	Insert Dia.						
392PSS-4-4	1/4	1/4	1/2-24	0.625	0.84	0.28	2.03	1/2
392PSS-6-6	3/8	3/8	11/16-24	0.812	0.93	0.31	2.20	11/16

393PD Shut-off Type Insert (Chrome Plated)

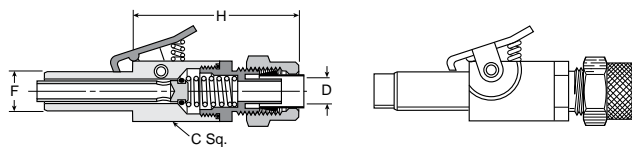

393PD-4-4

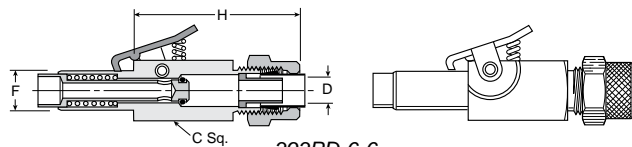

393PD-6-6

Part No.	Tube Size	Insert Dia.	Straight Thread	C Square	H	Flow
						Dia. D
393PD-4-4	1/4	1/4	3/8-24	7/16	1.61	0.110
393PD-6-6	3/8	3/8	1/2-24	1/2	1.45	0.187

393P Through Type Insert (Chrome Plated)

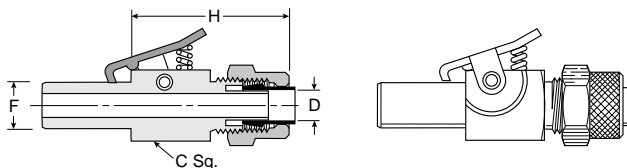

Part No.	Tube Size	Insert Dia.	Straight Thread	C Square	H	Flow
						Dia. D
393P-4-4	1/4	1/4	3/8-24	7/16	1.12	0.125
393P-6-6	3/8	3/8	1/2-24	1/2	1.34	0.203

393PDSS Shut-off Type Insert (Stainless Steel)

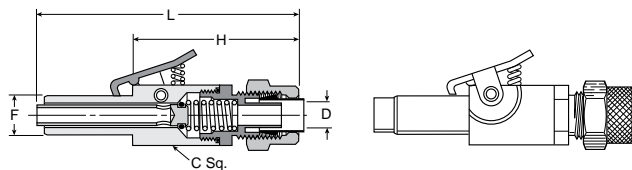

Part No.	Tube Size	Insert Dia.	L	C Square	H	Flow
						Dia. D
393PDSS-4-4	1/4	1/4	2.46	0.500	1.62	0.116
393PDSS-6-6	3/8	3/8	2.60	0.500	1.67	0.157

394P Single End Shut-off Bulkhead Quick Coupler (Chrome Plated)

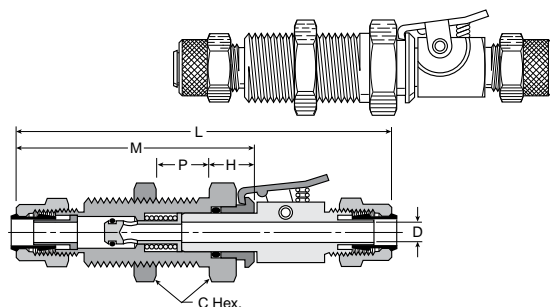

393PSS Through Type Insert (Stainless Steel)

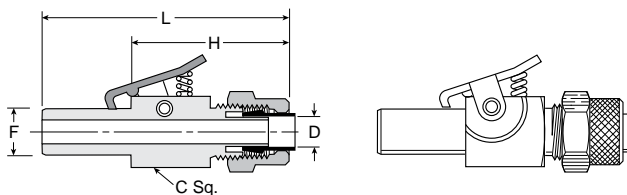

Part No.	Tube Size	Insert Dia.	L	C Square	H	Flow
						Dia. D
393PSS-4-4	1/4	1/4	1.677	0.500	0.99	0.125
393PSS-6-6	3/8	3/8	2.030	0.500	1.27	0.203

Part No.	Tube Size	Straight Thread	C Hex.	P Max.	H	L	M	Bulkhead	Flow
								Hole Dia.	Dia. D
394P-4-4	1/4	1/2-24	5/8	0.84	0.39	3.28	2.13	1/2	0.125
394P-6-6	3/8	11/16-24	13/16	0.93	0.37	3.41	2.01	11/16	0.203



394PSS Single End Shut-off Bulkhead Quick Coupler (Stainless Steel)

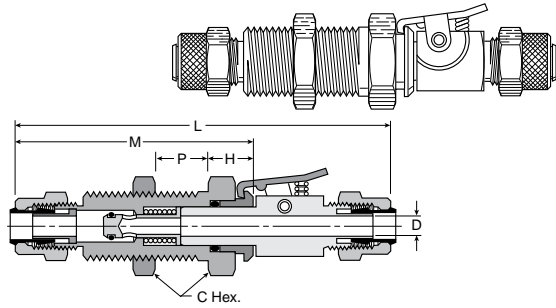

Part No.	Tube Size	Straight Thread	C Hex.	P Max.	H	L	M	Flow Dia. D
394PSS-4-4	1/4	1/2 - 24	0.625	0.84	0.31	3.05	2.06	0.125
394PSS-6-6	3/8	11/16-24	0.812	0.93	0.34	3.50	2.23	0.203

394PDSS Double End Shut-off Bulkhead Quick Coupler (Stainless Steel)

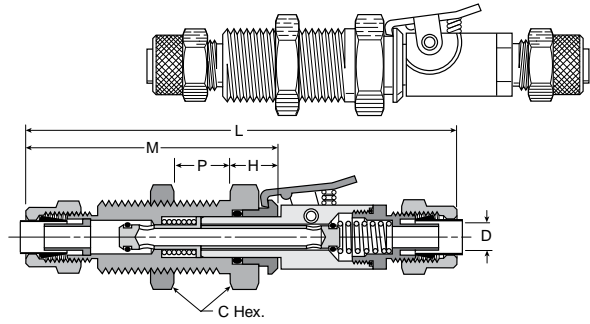

Part No.	Tube Size	Straight Thread	C Hex.	P Max.	H	L	M	Flow Dia. D
394PDSS-4-4	1/4	1/2-24	0.625	0.84	0.32	3.69	2.67	0.125
394PDSS-6-6	3/8	11/16-24	0.812	0.93	0.34	3.91	2.24	0.204

394PD Double End Shut-off Bulkhead Quick Coupler (Chrome Plated)

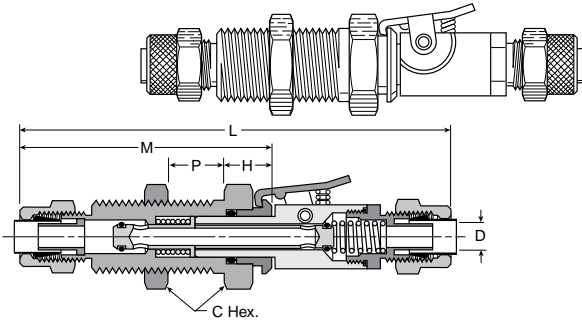

394PD-4-4

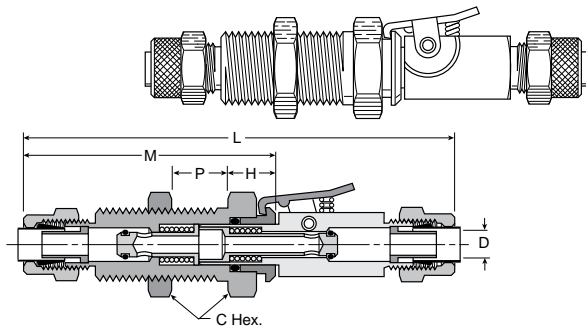

394PD-6-6

Part No.	Tube Size	Straight Thread	C Hex.	P Max.	H	L	M	Bulk-head Hole Dia.	Flow Dia. D
394PD-4-4	1/4	1/2-24	5/8	0.84	0.39	3.77	2.13	1/2	0.125
394PD-6-6	3/8	11/16-24	13/16	0.93	0.47	3.48	2.01	11/16	0.204

398P Single End Shut-off Pipe Connector Quick Coupler (Chrome Plated)

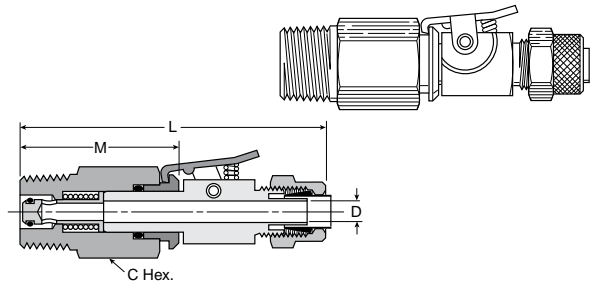

Part No.	Tube Size	Pipe Thread	Straight Thread	C Hex.	L	M	Flow Dia. D
398P-4-2	1/4	1/8	3/8-24	1/2	2.45	1.32	0.125
398P-4-4	1/4	1/4	3/8-24	9/16	2.45	1.32	0.125
398P-6-4	3/8	1/4	1/2-24	5/8	2.80	1.46	0.203

398PSS Single End Shut-off Pipe Connector Quick Coupler (Stainless Steel)

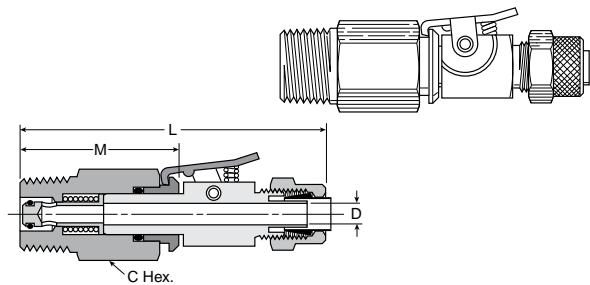

Part No.	Tube Size	Pipe Thread	Straight Thread	C Hex.	L	M	Flow Dia. D
398PSS-4-2	1/4	1/8	3/8-24	0.500	2.30	1.32	0.125
398PSS-4-4	1/4	1/4	3/8-24	0.562	2.30	1.32	0.125
398PSS-6-4	3/8	1/4	1/2-24	0.625	2.70	1.46	0.203

F



398PD Double End Shut-off Pipe Connector Quick Coupler (Chrome Plated)

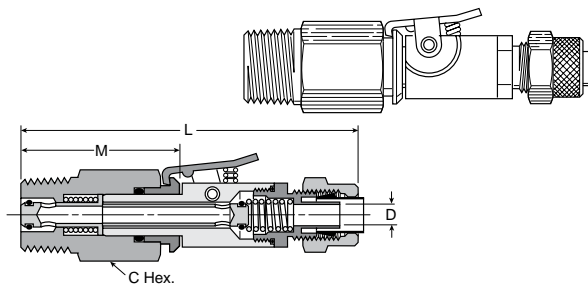

394PD-4-X

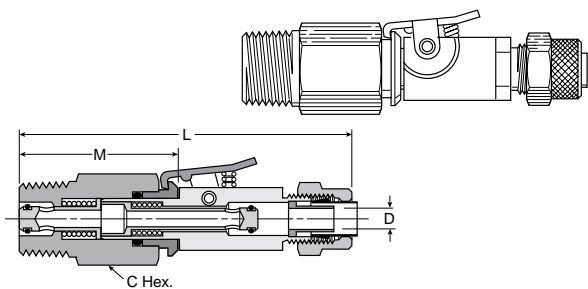

394PD-6-4

Part No.	Tube Size	Pipe Thread	Straight Thread	C Hex.	L	M	Flow Dia. D
398PD-4-2	1/4	1/8	3/8-24	1/2	2.93	1.31	0.125
398PD-4-4	1/4	1/4	3/8-24	9/16	2.93	1.32	0.125
398PD-6-4	3/8	1/4	1/2-24	5/8	2.88	1.43	0.204

398PDSS Double End Shut-off Pipe Connector Quick Coupler (Stainless Steel)

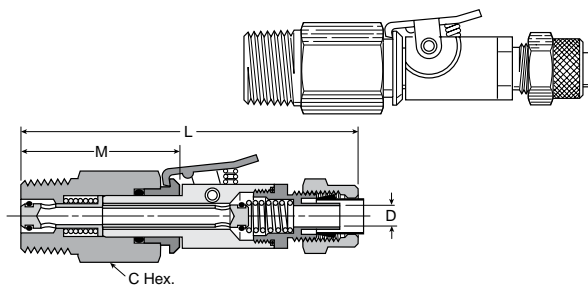

Part No.	Tube Size	Pipe Thread	Straight Thread	C Hex.	L	M	Flow Dia. D
398PDSS-4-2	1/4	1/8	3/8-24	0.500	2.93	1.31	0.125
398PDSS-4-4	1/4	1/4	3/8-24	0.562	2.93	1.31	0.125
398PDSS-6-4	3/8	1/4	1/2-24	0.625	3.10	1.43	0.125

164P-264P Union Tee

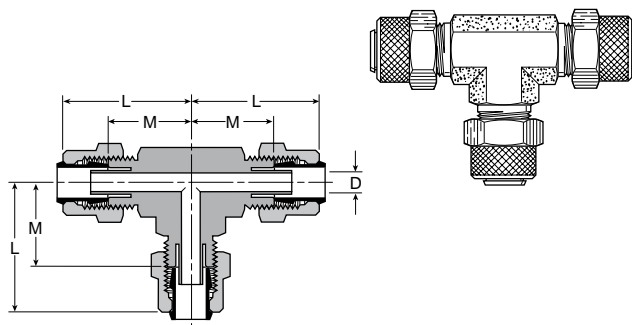

Part No.	Tube Size	Straight Thread	L	M	Flow Dia. D
164P-2*	1/8	5/16-24	0.83	0.61	0.094
264P-3*	3/16	3/8-24	0.83	0.61	0.125
164P-4	1/4	3/8-24	0.84	0.73	0.125
164P-5	5/16	7/16-24	0.83	0.73	0.144
164P-6	3/8	1/2-24	0.98	0.86	0.203
164P-8	1/2	11/16-20	1.12	1.04	0.323

*Brass Sleeve, No Tube Support

164P Union Tee Combination Size

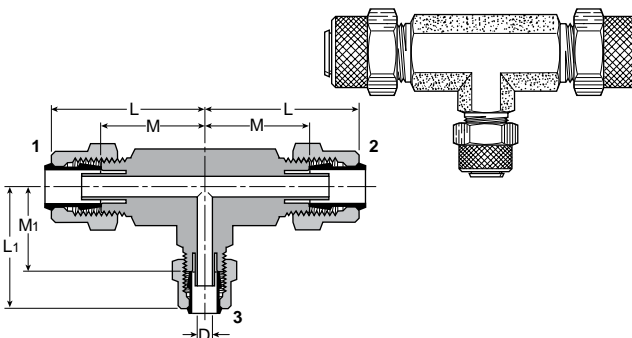

Part No.	1 Tube Size	2 Tube Size	3 Tube Size	L	L1	M	M1	Flow Dia. D
164P-6-4	3/8	3/8	1/4	0.98	0.90	0.86	0.79	0.125



169P-269P Male Elbow

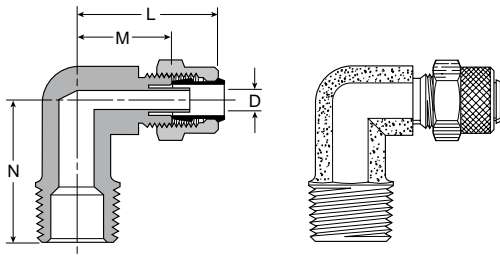

Part No.	Tube Size	Pipe Thread	Straight Thread	L	M	N	Flow Dia. D
169P-2-1	1/8	1/16	5/16-24	0.88	0.63	0.69	0.094
269P-2-2*	1/8	1/8	5/16-24	0.83	0.61	0.67	0.094
169P-3-1	3/16	1/16	3/8-24	0.88	0.63	0.69	0.094
169P-3-2*	3/16	1/8	3/8-24	0.83	0.61	0.69	0.125
169P-3-4*	3/16	1/4	3/8-24	0.85	0.63	0.94	0.125
169P-4-1	1/4	1/16	3/8-24	0.92	0.58	0.67	0.130
169P-4-2	1/4	1/8	3/8-24	0.84	0.73	0.75	0.121
169P-4-4	1/4	1/4	3/8-24	0.90	0.79	0.92	0.125
169P-4-6	1/4	3/8	3/8-24	0.93	0.84	1.08	0.125
169P-5-2	5/16	1/8	7/16-24	0.87	0.73	0.68	0.144
169P-6-2	3/8	1/8	1/2-24	0.93	0.81	0.73	0.203
169P-6-4	3/8	1/4	1/2-24	0.98	0.86	1.05	0.203
169P-6-6	3/8	3/8	1/2-24	0.98	0.86	1.08	0.203
169P-8-6	1/2	3/8	11/16-20	1.12	1.04	1.13	0.323

*Brass Sleeve, No Tube Support

169LP Long Male Elbow

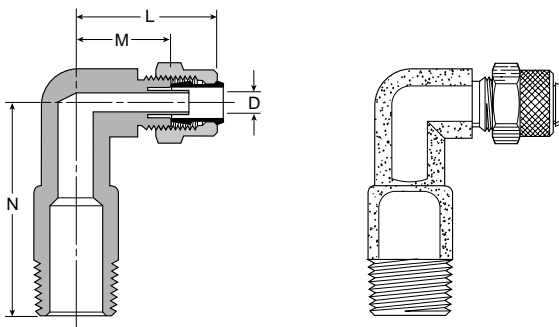

Part No.	Tube Size	Pipe Thread	Straight Thread	L	M	N	Flow Dia. D
169LP-4-4	1/4	1/4	3/8-24	0.90	0.79	1.38	0.125

169PS Male Elbow Swivel

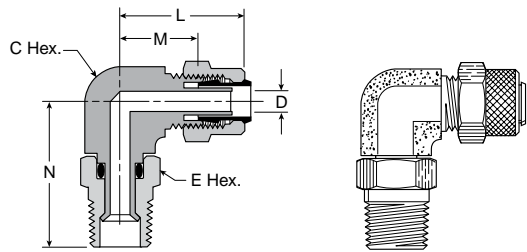

Part No.	Tube Size	Pipe Thread	C Hex.	E Hex.	L	M	N	Flow Dia. D
169PS-4-2	1/4	1/8	3/8	7/16	0.812	0.594	0.862	0.121
169PS-4-4	1/4	1/4	9/16	9/16	0.906	0.688	1.218	0.125
169PS-6-2	3/8	1/8	7/16	7/16	0.875	0.625	0.904	0.203
169PS-6-4	3/8	1/4	9/16	9/16	0.937	0.685	1.218	0.203
169PS-6-6	3/8	3/8	9/16	11/16	0.859	0.602	1.190	0.203
169PS-8-6	1/2	3/8	1/2	11/16	1.031	0.782	1.218	0.323

170P Female Elbow

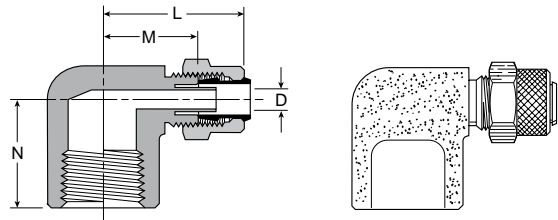

Part No.	Tube Size	Pipe Thread	Straight Thread	L	M	N	Flow Dia. D
170P-2-2*	1/8	1/8	5/16-24	0.91	0.69	0.56	0.094
170P-3-2*	3/16	1/8	3/8-24	0.91	0.69	0.56	0.125
170P-4-2	1/4	1/8	3/8-24	0.90	0.79	0.56	0.125
170P-4-4	1/4	1/4	3/8-24	1.00	0.89	0.69	0.125
170P-6-4	3/8	1/4	1/2-24	1.01	0.89	0.69	0.204
170P-8-6	1/2	3/8	11/16-20	1.19	1.11	1.13	0.323

*Brass Sleeve, No Tube Support

171P Male Run Tee

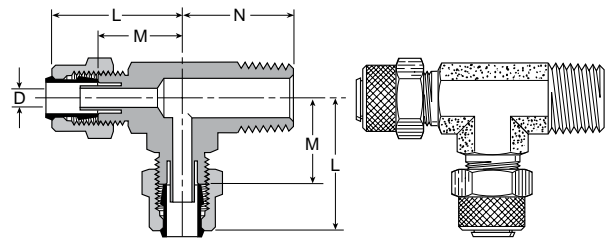

Part No.	Tube Size	Pipe Thread	Straight Thread	L	M	N	Flow Dia. D
171P-2-2*	1/8	1/8	5/16-24	0.82	0.60	0.67	0.094
171P-3-2*	3/16	1/8	3/8-24	0.82	0.60	0.67	0.125
171P-4-2	1/4	1/8	3/8-24	0.84	0.73	0.72	0.125
171P-4-4	1/4	1/4	3/8-24	0.92	0.81	0.92	0.125
171P-5-2	5/16	1/8	7/16-24	0.83	0.73	0.72	0.144
171P-6-4	3/8	1/4	1/2-24	0.98	0.86	1.03	0.203
171P-8-6	1/2	3/8	11/16-20	1.12	1.04	1.13	0.323

*Brass Sleeve, No Tube Support

F



172P Male Branch Tee

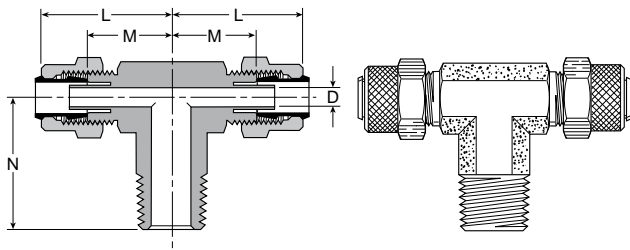

Part No.	Tube Size	Pipe Thread	Straight Thread	L	M	N	Flow Dia. D
172P-2-2*	1/8	1/8	5/16-24	0.82	0.60	0.67	0.094
172P-3-2*	3/16	1/8	3/8-24	0.82	0.60	0.67	0.125
172P-4-2	1/4	1/8	3/8-24	0.84	0.73	0.72	0.125
172P-4-4	1/4	1/4	3/8-24	0.92	0.81	0.92	0.125
172P-5-2	5/16	1/8	7/16-24	0.83	0.73	0.72	0.144
172P-6-2	3/8	1/8	1/2-24	0.88	0.86	0.74	0.204
172P-6-4	3/8	1/4	1/2-24	0.98	0.86	1.03	0.204
172P-8-6	1/2	3/8	11/16-20	1.12	1.04	1.13	0.323

*Brass Sleeve, No Tube Support

177P Female Branch Tee

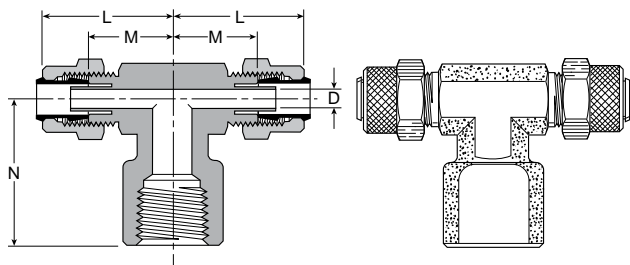

Part No.	Tube Size	Pipe Thread	Straight Thread	L	M	N	Flow Dia. D
177P-4-2	1/4	1/8	3/8-24	0.92	0.81	0.88	0.125
177P-4-4	1/4	1/4	3/8-24	0.92	0.81	1.03	0.125
177P-4-6	1/4	3/8	3/8-24	1.03	0.92	1.13	0.125

NV311P Needle Valve

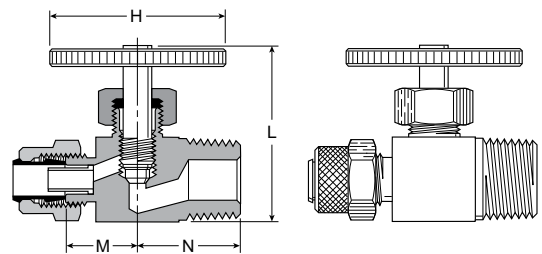

Part No.	Tube Size	Pipe Thread	H	L Open	L Closed	M	N
NV311P-4-2	1/4	1/8	1.06	1.36	1.16	0.64	0.63
NV311P-4-4	1/4	1/4	1.06	1.38	1.18	0.64	0.72
NV311P-6-4	3/8	1/4	1.06	1.38	1.18	0.64	0.72

NV312P Angle Needle Valve

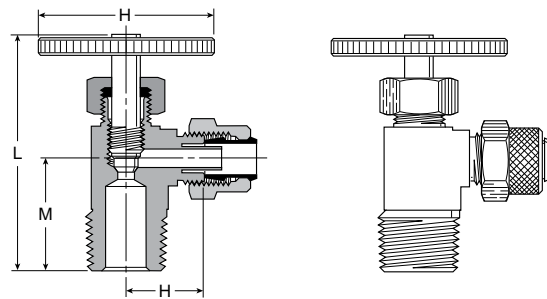

Part No.	Tube Size	Pipe Thread	H	L Open	L Closed	M	N
NV312P-4-2	1/4	1/8	1.06	1.70	1.50	0.63	0.68
NV312P-4-4	1/4	1/4	1.06	2.07	1.82	0.71	0.86
NV312P-6-4	3/8	1/4	1.06	2.00	1.75	0.74	0.86



32PL Equal Union (Composite Body)

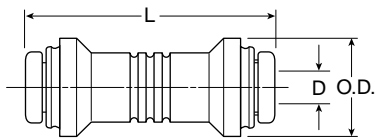

Part No.	Tube Size	O.D.	L	Flow Dia. D
32PL-2	1/8	0.51	1.32	0.09
32PL-5/32	5/32	0.51	1.32	0.12
32PL-3	3/16	0.59	1.37	0.16
32PL-4	1/4	0.59	1.37	0.19
32PL-5	5/16	0.67	1.49	0.25
32PL-6	3/8	0.82	1.76	0.31

HPB Equal Union

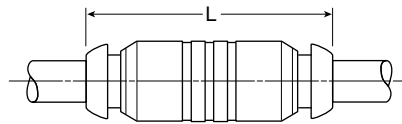

Part No.	Tube Size (mm)	L (mm)
HPB-4	4	33.0
HPB-5	5	34.5
HPB-6	6	36.0
HPB-8	8	38.0
HPB-10	10	48.0
HPB-12	12	48.0
HPB-14	14	54.0

32PL Unequal Union (Composite Body)

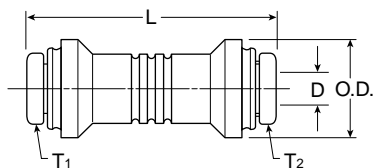

Part No.	Tube 1 Size	Tube 2 Size	O.D.	L	Flow Dia. D
32PL-5/32-2	5/32	1/8	0.51	1.32	0.09
32PL-4-2	1/4	1/8	0.59	1.37	0.09
32PL-5-4	5/16	1/4	0.67	1.47	0.19
32PL-6-4	3/8	1/4	0.82	1.75	0.19

HPK Equal Union

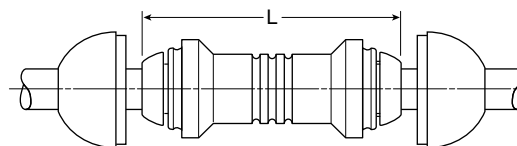

Part No.	Tube Size (mm)	L (mm)
HPK-4	4	33.5
HPK-6	6	37.0
HPK-8	8	39.0
HPK-10	10	48.0
HPK-12	12	49.0
HPK-14	14	54.0

62PLP Union (Nickle Plated)

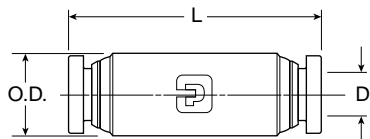

Part No.	Tube Size	O.D.	L	Flow Dia. D
62PLP-2	1/8	0.375	1.40	0.094
62PLP-3	3/16	0.437	1.41	0.156
62PLP-5/32	5/32	0.375	1.41	0.125
62PLP-4	1/4	0.500	1.43	0.188
62PLP-5	5/16	0.562	1.65	0.250
62PLP-6	3/8	0.625	1.66	0.312
62PLP-8	1/2	0.750	1.82	0.375

HPK Unequal Union

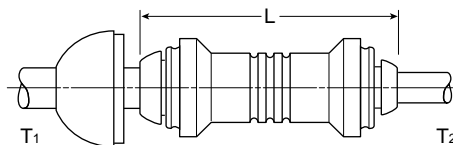

Part No.	Tube 1 Size (mm)	Tube 1 Size (mm)	L (mm)
HPK6-4	4	4	36.0
HPK8-4	8	4	38.0
HPK8-6	8	6	39.0
HPK10-6	10	6	47.0
HPK10-8	10	8	47.0
HPK12-10	12	10	49.5



62PLPBH Bulkhead Union

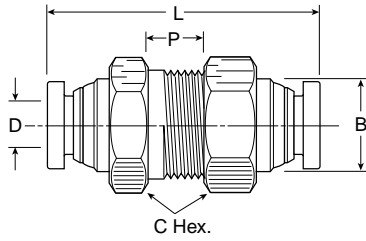

Part No.	Tube Size	B	C Hex.	P Max.	L	D
62PLPBH-2	1/8	7/16	9/16	0.39	1.40	0.094
62PLPBH-5/32	5/32	7/16	9/16	0.39	1.41	0.125
62PLPBH-4	1/4	9/16	11/16	0.29	1.43	0.188
62PLPBH-5	5/16	5/8	3/4	0.60	1.65	0.250
62PLPBH-6	3/8	3/4	7/8	0.54	1.66	0.312
62PLPBH-8	1/2	7/8	1	0.66	2.04	0.375

WBMPB Mixed Bulkhead Union

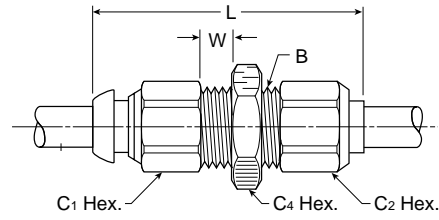

Part No.	Tube 1 Size (mm)	Tube 2 Size (mm)	B Thread (mm)	C1 Hex. (mm)	C2 Hex. (mm)	C4 Hex. (mm)	L (mm)	W (mm)	Bulkhead Hole Dia. (mm)
WBMPB4	4	4	M8x1	10	10	12	34	5	11
WBMPB6	6	6	M10x1	12	10	12	37	5	13
WBMPB8	8	8	M12x1	14	14	16	39	5	16
WBMPB10	10	10	M14x1	17	17	19	45	5	18
WBMPB12	12	12	M16x1	22	19	22	49	5	23
WBMPB14	14	14	M18x1	24	22	22	52	7	24

63PL Double Male Union

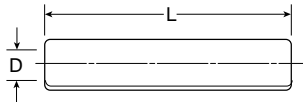

Part No.	Tube Size	L	D
63PL-2	1/8	1.49	0.078
63PL-5/32	5/32	1.49	0.106
63PL-4	1/4	1.61	0.188
63PL-5	5/16	1.61	0.236
63PL-6	3/8	2.00	0.295
63PL-8	1/2	2.22	0.374

BPK Double Male Union

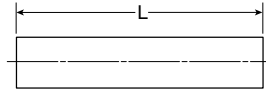

Part No.	Tube Size (mm)	L
BPK4	4	38
BPK6	6	41
BPK8	8	41
BPK10	10	51
BPK12	12	54
BPK14	14	55

WPB Bulkhead Union

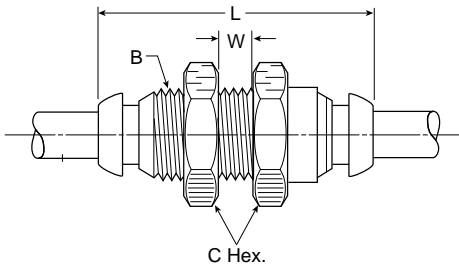

Part No.	Tube Size (mm)	B Thread (mm)	C Hex. (mm)	L (mm)	W (mm)	Bulkhead Hole Dia. (mm)
WPB4	4	M11x0.75	16	33	6	11
WPB6	6	M13x1	19	35	6	13
WPB8	8	M16x1.25	22	36	6	16
WPB10	10	M18x1	22	43	8	18
WPB12	12	M23x1.5	27	46	10	23
WPB14	14	M24x1.5	30	52	10	24

Jam nut is supplied loose in box.

66PLP Female Connector (Nickle Plated)

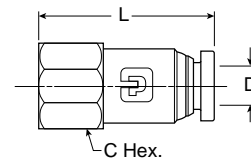

Part No.	Tube Size	B Thread (NPTF)	L	Flow Dia. D
66PLP-2-2	1/8	1/8	1.17	0.094
66PLP-3-2	3/16	1/8	1.13	0.156
66PLP-5/32-2	5/32	1/8	1.17	0.125
66PLP-5/32-4	5/32	1/4	1.38	0.125
66PLP-4-2	1/4	1/8	1.17	0.188
66PLP-4-4	1/4	1/4	1.38	0.188
66PLP-5-2	5/16	1/8	1.25	0.250
66PLP-5-4	5/16	1/4	1.45	0.250
66PLP-6-4	3/8	1/4	1.46	0.312
66PLP-6-6	3/8	3/8	1.51	0.312

F



G4PB Female Connector BSPP

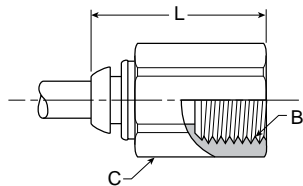

Part No.	Tube Size (mm)	Thread (BSPP)	C Hex. (mm)	L (mm)
G4PB4-1/8	4	1/8	14	26.0
G4PB6-1/8	6	1/8	14	27.5
G4PB6-1/4	6	1/4	17	33.0
G4PB8-1/8	8	1/8	17	29.0
G4PB8-1/4	8	1/4	17	33.0

66PLBH Female Bulkhead (Nickle Plated)

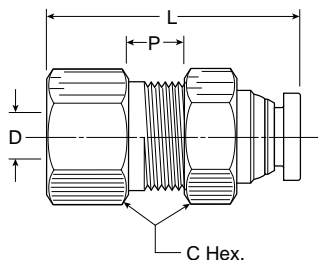

Part No.	Pipe				Flow Dia. D	Bulkhead Hole Dia.	
	Tube Size (NPTF)	C Hex.	P Max.	L			
66PLBH-5/32-4	5/32	1/8	11/16	0.19	1.39	0.125	1/2
66PLBH-4-4	1/4	1/8	11/16	0.24	1.35	0.188	9-16
66PLBH-6-6	3/8	1/4	1	0.22	1.47	0.312	7/8
66PLBH-8-6	1/2	1/8	1-1/4	0.35	1.56	0.344	1

WG4PB Bulkhead Union Female BSPP

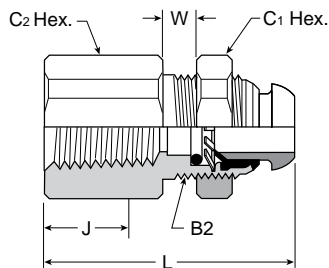

Part No.	Tube Size (mm)	Thread (BSPP)	B2	C1 Hex. (mm)	C2 Hex. (mm)	J (mm)	L (mm)	W (mm)
WG4PB4-1/8	4	G1/8	M1x0.75	14	14	8	25.0	6
WG4PB6-1/8	6	G1/8	M13x1	17	17	8	25.0	6
WG4PB6-1/4	6	G1/4	M13x1	17	19	12	29.5	6
WG4PB8-1/8	8	G1/8	M15x1.25	19	17	8	25.0	6
WG4PB8-1/4	8	G1/4	M15x1.25	19	19	12	30.0	6
WG4PB10-3/8	10	G3/8	M18x1	22	22	12	34.0	8
WG4PB12-3/8	12	G3/8	M23x1.25	27	24	12	35.0	10
WG4PB12-1/2	12	G1/2	M23x1.25	27	27	14	40.0	10

67PPL Tube End Reducer

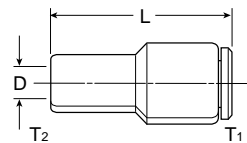

Part No.	Tube 1 Size	Tube 2 Size	L	Flow Dia. D
67PPL-2-5/32	1/8	5/32	1.76	0.120
67PPL-2-4	1/8	1/4	1.48	0.078
67PPL-5/32-4	5/32	1/4	1.32	0.125
67PPL-5/32-5	5/32	5/16	1.31	0.125
67PPL-5/32-6	5/32	3/8	1.64	0.125
67PPL-4-5	1/4	5/16	1.65	0.220
67PPL-4-6	1/4	3/8	1.76	0.220
67PPL-4-8	1/4	1/2	1.77	0.220
67PPL-5-6	5/16	3/8	1.81	0.220
67PPL-6-8	3/8	1/2	2.02	0.315

TRPB Tube End Reducer

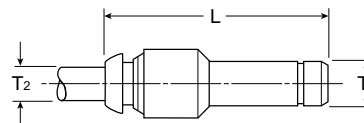

Part No.	Tube 1 Size (mm)	Tube 2 Size (mm)	L (mm)
TRPB6-4	6	4	40.0
TRPB6-4	8	4	39.5
TRPB8-6	8	6	41.5
TRPB10-4	10	4	37.0
TRPB10-6	10	6	43.0
TRPB10-8	10	8	47.5
TRPB12-6	12	6	38.0
TRPB12-8	12	8	44.0
TRPB12-10	12	10	52.0
TRPB14-8	14	8	41.0
TRPB14-10	14	10	51.0
TRPB14-12	14	12	55.0

TR2PK Tube End Reducer

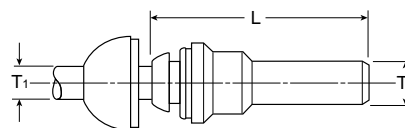

Part No.	Tube 1 Size (mm)	Tube 2 Size (mm)	L (mm)
TR2PK6-4	6	4	38
TR2PK6-4	8	4	36
TR2PK8-6	8	6	39
TR2PK10-4	10	4	41
TR2PK10-6	10	6	43
TR2PK10-8	10	8	47
TR2PK12-6	12	6	36
TR2PK12-8	12	8	38
TR2PK12-10	12	10	48
TR2PK14-8	14	8	39
TR2PK14-10	14	10	42
TR2PK14-12	14	12	51



TEPB Tube End Expander

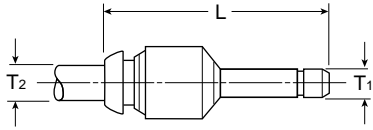

Part No.	Tube 1 Size (mm)	Tube 2 Size (mm)	L (mm)
TEPB4-6	4	6	39.0

W68PLP Male Connector (Nickle Plated)

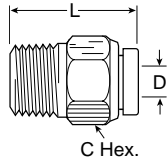

Part No.	Tube Size	Pipe Thread	C Hex.	L	Flow Dia. D
W68PLP-2-1	1/8	1/16	3/8	0.79	0.094
W68PLP-2-2	1/8	1/8	7/16	0.79	0.094
W68PLP-2-4	1/8	1/4	9/16	1.02	0.094
W68PLP-3-2	3/16	1/8	7/16	0.85	0.141
W68PLP-3-4	3/16	1/4	9/16	1.01	0.156
W68PLP-5/32-1	5/32	1/16		0.88	0.940
W68PLP-5/32-2	5/32	1/8	7/16	0.80	0.125
W68PLP-5/32-4	5/32	1/4	9/16	1.03	0.125
W68PLP-4-1	1/4	1/16	1/2	1.07	0.141
W68PLP-4-2	1/4	1/8	1/2	0.89	0.188
W68PLP-4-4	1/4	1/4	9/16	1.00	0.188
W68PLP-4-6	1/4	3/8	3/4	1.04	0.188
W68PLP-5-2	5-16	1/8	9/16	1.18	0.234
W68PLP-5-4	5-16	1/4	9/16	1.04	0.250
W68PLP-5-6	5/16	3/8	11/16	1.04	0.250
W68PLP-6-2	3/8	1/8	5/8	1.21	0.234
W68PLP-6-4	3/8	1/4	5/8	1.08	0.312
W68PLP-6-6	3/8	3/8	11/16	1.02	0.312
W68PLP-6-8	3/8	1/2	7/8	1.289	0.312
W68PLP-8-4	1/2	1/4	13/16	1.44	0.344
W68PLP-8-6	1/2	3/8	13/16	1.24	0.344
W68PLP-8-8	1/2	1/2	7/8	1.35	0.375
68PLP-5/32-4LT*	5/32	1/4-28	7/16	0.88	0.093

*SAE-LT Threads

68PLP-X-10x32 Male Connector (Nickle Plated)

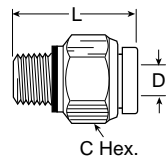

Part No.	Tube Size	Pipe Thread (NPTF)	C Hex.	L	Flow Dia. D
68PLP-2-0	1/8	10x32	3/8	0.92	0.094
68PLP-5/32-0	5/32	10x32			
68PLP-4-0	1/4	10x32	1/2	0.96	0.094

PLHBF4-B Male Connector BSPP

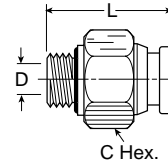

Part No.	Tube Size	Pipe Thread BSPP	C Hex.	L	Flow Dia. D
3-1/8PLHBF4-B	3/16	1/8-28	11/16	0.96	0.156
3-1/4PLHBF4-B	3/16	1/4-19	3/4	0.97	0.156
4-1/8PLHBF4-B	1/4	1/8-28	11/16	1.13	0.188
4-1/4PLHBF4-B	1/4	1/4-19	3/4	1.13	0.188
4-3/8PLHBF4-B	1/4	3/8-19	7/8	1.13	0.188
6-1/4PLHBF4-B	3/8	1/4-19	3/4	1.26	0.256
6-3/8PLHBF4-B	3/8	3/8-19	7/8	1.26	0.312
6-1/2PLHBF4-B	3/8	1/2-14	1-1/16	1.26	0.312
8-3/8PLHBF4-B	1/2	3/8-19	7/8	1.41	0.452
8-1/2PLHBF4-B	1/2	1/2-14	1-1/16	1.37	0.452

FPB Male Connector NPT

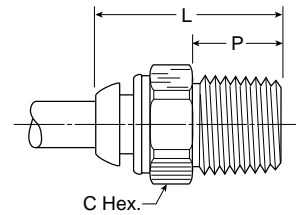

Part No.	Tube Size (mm)	Pipe Thread NPT	C Hex. (mm)	L (mm)	P (mm)	Int. Hex. (mm)
W68PLP-5/32-2	4	1/8-27	7/16"	21.7	9.7	—
W68PLP-5/32-4	4	1/4-18	9/16"	28.1	14.2	—
FPB6-1/8	6	1/8-27	14	26.0	10.1	4
FPB6-1/4	6	1/4-18	14	28.5	14.6	4
FPB10-1/4	10	1/4-18	19	40.0	14.6	8
FPB10-3/8	10	3/8-18	19	34.0	14.6	8
FPB12-3/8	12	3/8-18	22	36.5	14.6	10

F



F3PB Male Connector BSPT

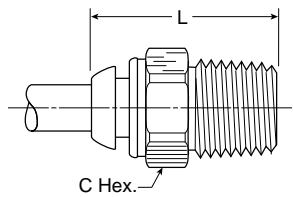

Part No.	Tube Size (mm)	Thread BSPT	C Hex. (mm)	L (mm)
F3PB4-1/8	4	1/8	12	20.5
F3PB4-1/4	4	1/4	14	23.0
F3PB5-1/8	5	1/8	11	22.5
F3PB5-1/4	5	1/4	14	28.5
F3PB6-1/8	6	1/8	14	24.0
F3PB6-1/4	6	1/4	14	24.0
F3PB8-1/8	8	1/8	17	28.0
F3PB8-1/4	8	1/4	17	28.5
F3PB8-3/8	8	3/8	17	26.5
F3PB10-1/4	10	1/4	19	35.5
F3PB10-3/8	10	3/8	19	33.0
F3PB10-1/2	10	1/2	22	31.0
F3PB12-1/4	12	1/4	22	36.5
F3PB12-3/8	12	3/8	22	36.0
F3PB12-1/2	12	1/2	22	36.0
F3PB14-3/8	14	3/8	24	39.0
F3PB14-1/2	14	1/2	24	37.0

F4PB Compact Male Connector BSPP

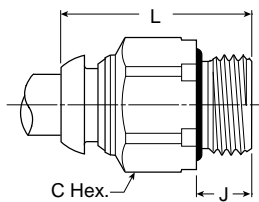

Part No.	Tube Size (mm)	Thread BSPP	C Hex. (mm)	J (mm)	L (mm)
F4PB4-1/8	4	1/8	13	6	21.7
F4PB4-1/4	4	1/4	16	9	23.2
F4PB6-1/8	6	1/8	13	6	25.3
F4PB6-1/4	6	1/4	16	9	26.0
F4PB8-1/8	8	1/8	14	6	27.4
F4PB8-1/4	8	1/4	16	9	27.4
F4PB8-3/8	8	3/8	20	9	28.0
F4PB10-1/4	10	1/4	17	9	35.4
F4PB10-3/8	10	3/8	20	9	31.4
F4PB10-1/2	10	1/2	24	12	30.3
F4PB12-1/4	12	1/4	20	9	36.0
F4PB12-3/8	12	3/8	20	9	35.7
F4PB12-1/2	12	1/2	24	12	34.1
F4PB14-3/8	14	3/8	22	9	38.3
F4PB14-1/2	14	1/2	24	12	37.4

F23PB Male Connector BSPT

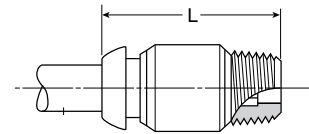

Part No.	Tube Size (mm)	Thread BSPT	L (mm)
F23PB4-1/8	4	1/8	21
F23PB6-1/8	6	1/8	24
F23PB6-1/4	6	1/4	28
F23PB8-1/8	8	1/8	28
F23PB8-1/4	8	1/4	28

This fitting has been designed for use where space is at a premium. It is assembled using the internal hexagon and an allen key.

F28PB Male Connector Metric Straight Thread

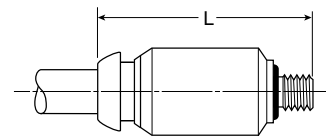

Part No.	Tube Size (mm)	Straight Thread (mm)	L (mm)
F28PB4M3	4	M3x0.5	24
F28PB4M5	4	M5x0.8	26
F28PB6M5	6	M5x0.8	26

This fitting has been designed for use where space is at a premium. It is assembled using the internal hexagon and an allen key.

F8PB Male Connector Metric Straight Thread

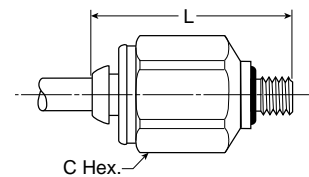

Part No.	Tube Size (mm)	Straight Thread (mm)	C Hex. (mm)	L (mm)
F8PB4M5	4	M3x0.8	12	25.5
F8PB4M10	4	M10x1	14	24.0
F8PB6M5	6	M5x0.8	14	26.0
F8PB6M10	6	M10x1	14	28.0
F8PB6M12	6	M12x1.5	17	30.0
F8PB8M12	8	M12x1.5	17	30.0
F8PB8M16	8	M16x1.5	22	28.0
F8PB8M22	6	M22x1.5	27	30.0



164PLP Union Tee (Nickle Plated)

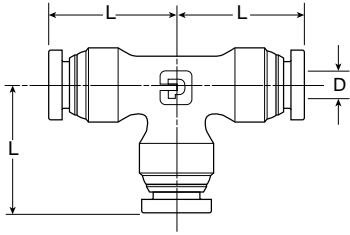

Part No.	Tube Size	L	Flow Dia. D
164PLP-2	1/8	0.74	0.094
164PLP-5/32	5/32	0.77	0.125
164PLP-3	3/16	0.82	0.156
164PLP-4	1/4	0.85	0.188
164PLP-5	5/16	0.97	0.250
164PLP-6	3/8	1.01	0.250
164PLP-8	1/2	1.15	0.375

364PL Union Tee (Composite Body)

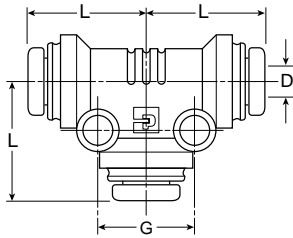

Part No.	Tube Size	Mounting Hole Dia.	L	G	Flow Dia. D
364PL-2	1/8	0.13	0.71	0.52	0.094
364PL-5/32	5/32	0.13	0.71	0.64	0.156
364PL-3	3/16	0.17	0.76	0.52	0.125
364PL-4	1/4	0.17	0.76	0.64	0.188
364PL-5	5/16	0.17	0.84	0.71	0.250
364PL-6	3/8	0.17	1.04	0.83	0.250
364PL-8	1/2	0.17	1.30	0.91	0.375

JPB Union Tee

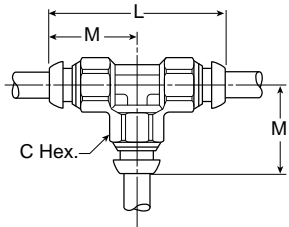

Part No.	Tube Size (mm)	C Hex. (mm)	L (mm)	M (mm)
JPB4	4	10	36	18
JPB5	5	12	41	21
JPB6	6	12	40	20
JPB8	8	14	44	22
JPB10	10	17	56	28
JPB12	12	22	60	30
JPB14	14	25	68	34

JPK Equal Tee

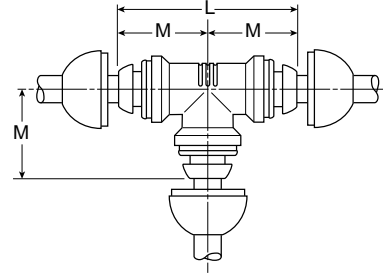

Part No.	Tube Size (mm)	L (mm)	M (mm)
JPK4	4	36	18.0
JPK6	6	41	20.5
JPK8	8	45	22.5
JPK10	10	57	28.5
JPK12	12	60	30.0
JPK14	14	67	33.5

JPK Unequal Tee

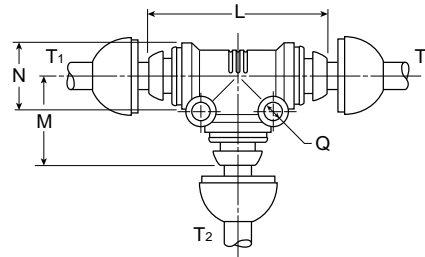

Part No.	Tube 1 Size (mm)	Tube 2 Size (mm)	L (mm)	M (mm)	N (mm)	Q (mm)
JPK6-6-4	6	4	41	21.5	15	17.0
JPK8-8-6	8	6	45	22.5	17	19.0
JPK10-10-8	10	8	57	28.5	21	23.5
JPK12-12-10	12	10	60	30.5	23	25.5
JPK4-4-6	4	6	43	20.5	15	17.0
JPK6-6-8	6	8	45	22.5	17	19.0
JPK8-8-10	8	10	57	28.5	21	23.5
JPK10-10-12	10	12	61	30.5	23	25.5

165PLP Union Elbow (Nickle Plated)

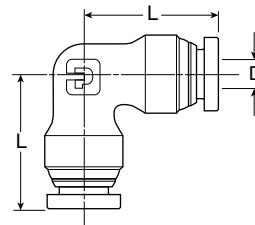

Part No.	Tube Size	L	Flow Dia. D
165PLP-2	1/8	0.74	0.094
165PLP-5/32	5/32	0.77	0.125
165PLP-3	3/16	0.82	0.156
165PLP-4	1/4	0.85	0.188
165PLP-5/32	5/32	0.97	0.250
165PLP-6	3/8	1.01	0.312
165PLP-8	1/2	1.15	0.375

F



365PL Union Elbow (Composite Body)

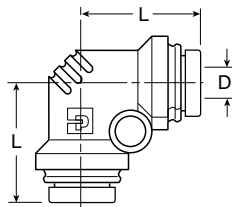

Part No.	Tube Size	Mounting Hole Dia.	L	Flow Dia. D
365PL-2	1/8	0.13	0.71	0.094
365PL-5/32	5/32	0.13	0.71	0.125
365PL-3	3/16	0.17	0.76	0.156
365PL-4	1/4	0.17	0.76	0.188
365PL-5	5/16	0.17	0.84	0.250
365PL-6	3/8	0.17	1.04	0.312
365PL-8	1/2	0.17	1.03	0.344

EPB 90° Union Elbow

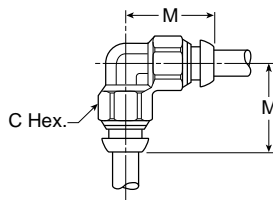

Part No.	Tube Size (mm)	C Hex. (mm)	M (mm)
EPB4	4	10	18.0
EPB5	5	12	20.5
EPB6	6	12	20.0
EPB8	8	14	22.0
EPB10	10	17	28.0
EPB12	12	22	30.0
EPB14	14	25	34.0

EPK Equal Elbow

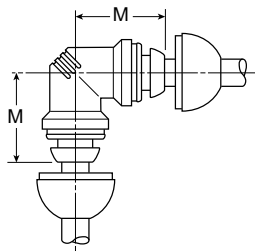

Part No.	Tube Size (mm)	M (mm)
EPK4	4	18.0
EPK6	6	20.5
EPK8	8	22.5
EPK10	10	28.5
EPK12	12	30.0
EPK14	14	33.5

WE6PB Adjustable Bulkhead Union Elbow

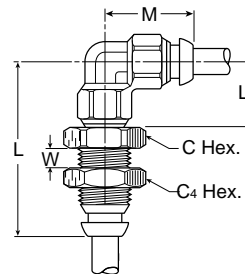

Part No.	Tube Size (mm)	Thread (mm)	C Hex. (mm)	C4 Hex. (mm)	L (mm)	L1 (mm)	M (mm)	W (mm)	Bulkhead Hole Dia. (mm)
WE6PB4	4	M11x0.75	14	16	41	18.0	18.0	6	11
WE6PB6	6	M13x1	17	17	45	19.5	20.5	6	13
WE6PB8	8	M15x1.25	19	19	57	21.5	22.5	6	15
WE6PB10	10	M18x1	22	22	60	22.8	28.5	8	18
WE6PB12	12	M23x1.5	27	27	43	30.0	30.0	10	23

WE6PK 90° Adjustable Bulkhead Union Elbow

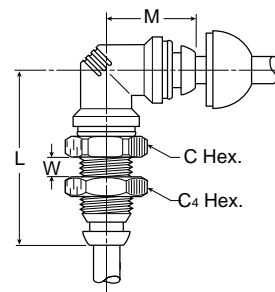

Part No.	Tube Size (mm)	Straight Thread (mm)	C Hex. (mm)	C4 Hex. (mm)	L (mm)	M (mm)	W (mm)	Bulkhead Hole Dia. (mm)
WE6PK4	4	M11x0.75	14	16	37	18.0	6	11
WE6PK6	6	M13x1	17	17	39	20.5	6	13
WE6PK8	8	M15x1.25	19	19	43	22.5	6	15
WE6PK10	10	M18x1	22	22	54	28.5	8	18
WE6PK12	12	M23x1.5	27	27	59	30.0	10	23



W169PLP Male Elbow Swivel 90° (Nickle Plated)

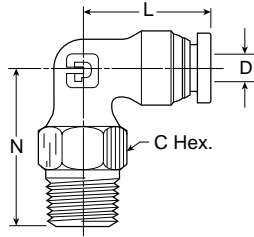

Part No.	Tube Size	Pipe		L	N	Flow Dia. D
		Thread (NPTF)	C Hex.			
W169PLP-2-2	1/8	1/8	7/16	0.74	0.92	0.094
169PLP-2-0	1/8	10-32	3/8	0.74	0.74	0.094
W169PLP-2-4	1/8	1/4	9/16	0.74	1.10	0.094
W169PLP-3-2	3/16	1/8	7/16	0.82	0.92	0.156
W169PLP-5/32-2	5/32	1/8	7/16	0.77	0.92	0.125
W169PLP-5/32-4	5/32	1/4	9/16	0.77	1.10	0.125
169PLP5/32-0	5/32	10-32	3/8	0.85	0.74	0.188
W169PLP-4-2	1/4	1/8	7/16	0.85	0.92	0.188
W169PLP-4-4	1/4	1/4	9/16	0.85	1.10	0.188
W169PLP-4-6	1/4	3/8	11/16	0.85	1.19	0.188
169PLP-4-0	1/4	10-32	3/8	0.85	0.74	0.188
W169PLP-5-2	5/16	1/8	9/16	0.97	1.02	0.250
W169PLP-5-4	5/16	1/4	9/16	0.97	1.24	0.250
W169PLP-6-2	3/8	1/8	9/16	1.01	1.02	0.312
W169PLP-6-4	3/8	1/4	9/16	1.01	1.24	0.312
W169PLP-6-6	3/8	3/8	11/16	1.01	1.24	0.312
W169PLP-6-8	3/8	1/2	7/8	1.01	1.48	0.312
W169PLP-8-4	1/2	1/4	9/16	1.15	1.28	0.375
W169PLP-8-6	1/2	3/8	11/16	1.15	1.31	0.375
W169PLP-8-8	1/2	1/2	7/8	1.15	1.52	0.375

W369PL Male Elbow Swivel 90° (Composite Body)

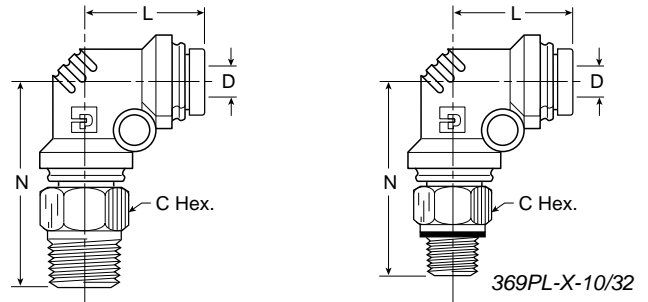

Part No.	Tube Size	Pipe		C Hex.	Mounting Hole Dia.	L	N	Flow Dia. D
		Thread (NPTF)	C Hex.					
W369PL-2-1	1/8	1/16	3/8	0.13	0.71	1.08	0.078	
W369PL-2-2	1/8	1/8	7/16	0.13	0.71	1.14	0.078	
369PL-2-10x32	1/8	10-32	3/8	0.13	0.71	0.94	0.078	
W369PL-2-4	1/8	1/4	9/16	0.13	0.71	1.32	0.078	
W369PL-3-2	3/16	1/8	7/16	0.17	0.76	1.20	0.147	
W369PL-3-4	3/16	1/4	9/16	0.17	0.76	1.44	0.147	
W369PL-5/32-2	5/32	1/8	7/16	0.13	0.74	1.14	0.094	
W369PL-5/32-4	5/32	1/4	9/16	0.13	0.74	1.32	0.094	
369PL5/32-10x32	5/32	10-32	3/8	0.13	0.74	0.94	0.094	
W369PL-4-1	1/4	1/16	7/16	0.17	0.76	1.20	0.094	
W369PL-4-2	1/4	1/8	7/16	0.17	0.76	1.20	0.172	
W369PL-4-4	1/4	1/4	9/16	0.17	0.76	1.38	0.172	
W369PL-4-6	1/4	3/8	11/16	0.17	0.76	1.42	0.172	
369PL-4-10x32	1/4	10-32	7/16	0.17	0.76	1.05	0.094	
W369PL-5-2	5/16	1/8	9/16	0.17	0.84	1.23	0.234	
W369PL-5-4	5/16	1/4	9/16	0.17	0.84	1.46	0.234	
W369PL-6-2	3/8	1/8	9/16	0.17	1.04	1.48	0.234	
W369PL-6-4	3/8	1/4	5/8	0.17	1.04	1.66	0.234	
W369PL-6-6	3/8	3/8	11/16	0.17	1.04	1.66	0.297	
W369PL-6-8	3/8	1/2	7/8	0.17	1.04	1.85	0.297	
W369PL-8-4	1/2	1/4	3/4	0.17	1.03	1.80	0.314	
W369PL-8-6	1/2	3/8	3/4	0.17	1.03	1.80	0.375	
W369PL-8-8	1/2	1/2	7/8	0.17	1.03	1.99	0.375	

C6PB Adjustable Male Elbow NPT

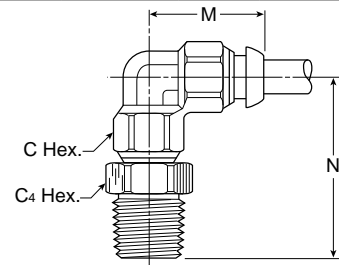

Part No.	Tube Size (mm)	Pipe Thread (NPT)	C Hex. (mm)	C4 Hex. (mm)	M (mm)	N (mm)
C6PB6-1/4	6	1/4-18	12	14	20	36.0
C6PB6-3/8	6	3/8-18	12	19	20	36.5
C6PB10-1/4	10	1/4-18	17	16	28	41.5
C6PB10-3/8	10	3/8-18	17	19	28	41.5
C6PB12-3/8	12	3/8-18	17	19	30	44.0
C6PB12-1/2	12	1/2-14	22	22	30	47.5

F



C63PB Adjustable Male Elbow BSPT

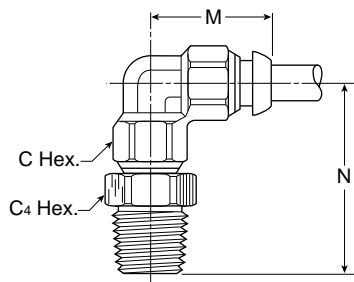

Part No.	Tube Size (mm)	Pipe Thread (NPTF)	C Hex. (mm)	M (mm)	N (mm)	Flow Dia. D (mm)
C63PB4-1/8	4	1/8	10	10	18	26.5
C63PB4-1/4	4	1/4	10	14	18	30.0
C63PB6-1/8	6	1/8	12	11	20	28.0
C63PB6-1/4	6	1/4	12	14	20	31.0
C63PB8-1/8	8	1/8	14	14	22	30.0
C63PB8-1/4	8	1/4	14	14	22	33.0
C63PB8-3/8	8	3/8	14	17	22	34.5
C63PB10-1/4	10	1/4	17	17	28	40.0
C63PB10-3/8	10	3/8	17	17	28	39.0
C63PB12-1/4	12	1/4	22	19	30	42.0
C63PB12-3/8	12	3/8	22	19	30	41.0
C63PB12-1/2	12	1/2	22	22	30	44.5
C63PB14-3/8	14	3/8	25	22	34	46.0
C63PB14-1/2	14	1/2	25	22	34	48.5

PLE2BF4-K Male Elbow BSPP (Composite Body)

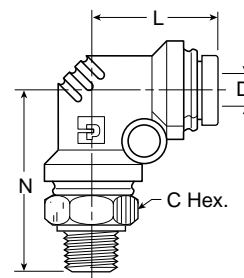

Part No.	Tube Size (BSPP)	Pipe Thread (BSPP)	Mounting Hole Dia.	C Hex.	L	N	Flow Dia. D
3-1/8PLE2BF4-K	3/16	1/8-28	11/16	0.17	0.76	1.17	0.147
3-1/4PLE2BF4-K	3/16	1/4-19	3/4	0.17	0.76	1.31	0.147
4-1/8PLE2BF4-K	1/4	1/8-28	11/16	0.17	0.76	1.06	0.177
4-1/4PLE2BF4-K	1/4	1/4-19	3/4	0.17	0.76	1.31	0.172
4-3/8PLE2BF4-K	1/4	3/8-19	7/8	0.17	0.76	1.31	0.182
6-1/4PLE2BF4-K	3/8	1/4-19	3/4	0.17	1.04	1.57	0.297
6-3/8PLE2BF4-K	3/8	3/8-19	7/8	0.17	1.04	1.68	0.297
6-1/2PLE2BF4-K	3/8	1/2-14	1-1/16	0.17	1.04	1.83	0.297
8-3/8PLE2BF4-K	1/2	3/8-19	7/8	0.17	1.03	1.63	0.344
8-1/2PLE2BF4-K	1/2	1/2-14	1-1/16	0.17	1.03	1.78	0.344

C63PK Adjustable Male Elbow BSPT

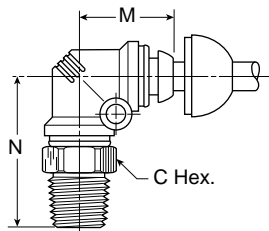

Part No.	Tube Size (mm)	Thread (BSPT)	C Hex. (mm)	M (mm)	N (mm)
C63PK4-1/8	4	1/8	10	18.0	25.5
C63PK4-1/4	4	1/4	14	18.0	29.0
C63PK6-1/8	6	1/8	11	20.5	27.0
C63PK6-1/4	6	1/4	14	20.5	30.5
C63PK8-1/8	8	1/8	14	22.5	29.5
C63PK8-1/4	8	1/4	14	22.5	32.5
C63PK8-3/8	8	3/8	17	28.5	40.0
C63PK10-1/4	10	1/4	17	28.5	40.0
C63PK10-3/8	10	3/8	17	28.5	39.0
C63PK12-1/4	12	1/4	19	30.0	41.5
C63PK12-3/8	12	3/8	19	30.0	41.0
C63PK12-1/2	12	1/2	22	30.0	44.5
C63PK14-3/8	14	3/8	22	33.5	45.5
C63PK14-1/2	14	1/2	22	33.5	48.0

C64PB Adjustable Male Elbow BSPP

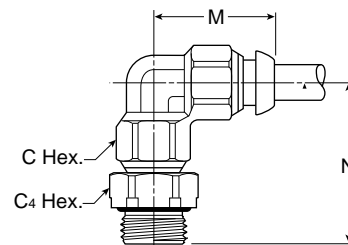

Part No.	Tube Size (mm)	Thread (BSPP)	C Hex. (mm)	C4 Hex. (mm)	M (mm)	N (mm)
C64PB4-1/8	4	1/8	10	14	18	26.5
C64PB4-1/4	4	1/4	10	19	18	31.5
C64PB6-1/8	6	1/8	12	14	20	30.0
C64PB6-1/4	6	1/4	12	19	20	33.0
C64PB8-1/8	8	1/8	14	14	22	30.0
C64PB8-1/4	8	1/4	14	19	22	35.0
C64PB8-3/8	8	3/8	14	22	22	36.0
C64PB10-1/4	10	1/4	17	19	28	39.0
C64PB10-3/8	10	3/8	17	22	28	40.0
C64PB12-1/4	12	1/4	22	19	30	41.0
C64PB12-3/8	12	3/8	22	22	30	42.0
C64PB14-3/8	14	3/8	25	22	34	46.0
C64PB14-1/2	14	1/2	25	27	34	50.5



C64PK Adjustable Male Elbow BSPP

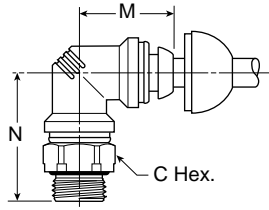

Part No.	Tube Size (mm)	Thread (BSPP)	C Hex. (mm)	M (mm)	N (mm)
C64PK4-1/8	4	1/8	14	18.0	25.5
C64PK4-1/4	4	1/4	19	18.0	30.5
C64PK6-1/8	6	1/8	14	20.5	27.0
C64PK6-1/4	6	1/4	19	20.5	32.0
C64PK8-1/8	8	1/8	14	22.5	29.0
C64PK8-1/4	8	1/4	19	22.5	34.0
C64PK8-3/8	8	3/8	22	22.5	35.0
C64PK10-1/4	10	1/4	19	28.5	39.0
C64PK10-3/8	10	3/8	22	28.5	40.0
C64PK12-1/4	12	1/4	19	30.0	40.5
C64PK12-3/8	12	3/8	22	30.0	41.5
C64PK14-3/8	14	3/8	22	33.5	45.0
C64PK14-1/2	14	1/2	27	33.5	49.5

C64SPB Adjustable Male Elbow BSPP

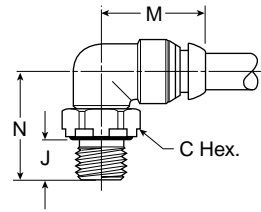

Part No.	Tube Size (mm)	Thread (BSPP)	C Hex. (mm)	J (mm)	M (mm)	N (mm)
C64SPB4-1/8	4	1/8	13	6	17	18.0
C64SPB6-1/8	6	1/8	13	6	22	18.0
C64SPB6-1/4	6	1/4	16	9	22	21.5
C64SPB8-1/8	8	1/8	13	6	25	18.0
C64SPB8-1/4	8	1/4	16	9	25	21.0
C64SPB8-3/8	8	3/8	19	9	25	21.0
C64SPB10-1/4	10	1/4	16	9	30	23.0
C64SPB10-3/8	10	3/8	19	9	30	23.0
C64SPB12-1/4	12	1/8	16	9	32	24.0
C64SPB12-3/8	12	3/8	19	9	32	24.0
C64SPB12-1/2	12	1/2	24	12	32	29.0

W369PLC Compact Male Elbow

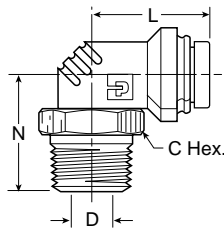

Part No.	Tube Size	Pipe		C Hex.	L	N	Flow Dia. D
		Thread (NPTF)	C Hex.				
W369PLC-2-2	1/8	1/8	7/16	0.81	0.71	0.08	
W369PLC-5/32-2	5/32	1/8	7/16	0.83	0.71	0.08	
W369PLC-5/32-4	5/32	1/4	9/16	0.83	0.89	0.08	
W369PLC-3-2	3/16	1/8	7/16	0.86	0.81	0.08	
W369PLC-4-2	1/4	1/8	7/16	0.86	0.81	0.08	
W369PLC-5-4	5/16	1/4	9/16	0.94	0.97	0.11	
W369PLC-6-4	3/8	1/4	5/8	1.13	1.07	0.20	
W369PLC-6-6	3/8	3/8	3/4	1.13	1.15	0.20	

C68PB Adjustable Male Elbow Metric Straight Thread

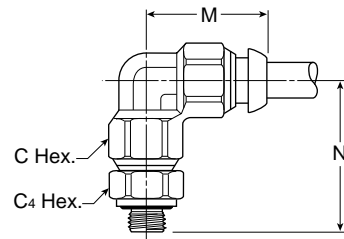

Part No.	Tube Size (mm)	Straight Thread (mm)	C Hex. (mm)	C4 Hex. (mm)	M (mm)	N (mm)
C68PB4M3	4	M3x0.5	10	10	18	23.0
C68PB4M5	4	M5x0.8	10	10	18	24.5
C68PB6M5	6	M5x0.8	12	11	20	25.5

C68SPB Compact Adjustable Male Elbow Metric Straight Thread

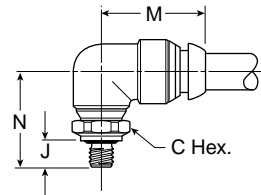

Part No.	Tube Size (mm)	Straight Thread (mm)	C Hex. (mm)	C4 Hex. (mm)	M (mm)	N (mm)
C68SPB4M5	4	M5x0.8	12.5	5	17	18
C68SPB6M5	6	M5x0.8	12.5	5	17	18

F



C64SPK Compact Adjustable Male Elbow BSPP

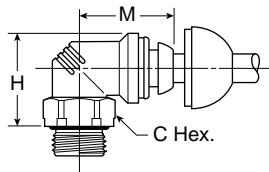

Part No.	Tube Size (mm)	Thread (BSPP)	C Hex. (mm)	H (mm)	M (mm)
C64SPK4-1/8	4	1/8	14	16.7	20.5
C64SPK4-1/4	4	1/4	19	17.4	20.5
C64SPK6-1/8	6	1/8	14	17.9	23.0
C64SPK6-1/4	6	1/4	19	19.4	23.0
C64SPK8-1/8	8	1/8	14	18.9	25.0
C64SPK8-1/4	8	1/4	19	20.4	25.0
C64SPK8-3/8	8	3/8	22	21.9	25.0

C68PK Adjustable Male Elbow Metric Straight Thread

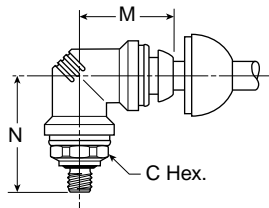

Part No.	Tube Size (mm)	Thread (BSPP)	C Hex. (mm)	M (mm)	N (mm)
C68PK4M3	4	M3x0.5	10	18.0	22.0
C68PK4M5	4	M5x0.8	10	18.0	23.5
C68PK6M5	6	M5x0.8	11	20.5	25.0
C68PK8M12	8	M12x1.5	17	22.5	35.0
C68PK8M16	8	M16x1.5	22	22.5	35.0
C68PK8M22	8	M22x1.5	27	22.5	39.0
C68PK10M12	10	M12x1.5	17	30.0	40.0

C68SPK Compact Adjustable Male Elbow Metric Straight Thread

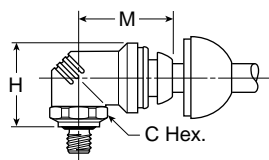

Part No.	Tube Size (mm)	Thread (BSPP)	C Hex. (mm)	H (mm)	M (mm)
C68SPK4M53	4	M5x0.8	10	15.5	20.5

W169PLPNS Male Elbow 90° (Nickle Plated)

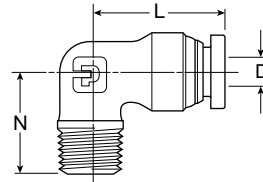

Part No.	Tube Size	Pipe Thread (NPTF)	L	N	Flow Dia. D
W169PLPNS-2-2	1/8	1/8	0.74	0.67	0.094
W169PLPNS5/32-2	5/32	1/8	0.77	0.67	0.125
W169PLPNS5/32-4	5/32	1/4	0.77	0.87	0.125
W169PLPNS-4-2	1/4	1/8	0.85	0.67	0.188
W169PLPNS-4-4	1/4	1/4	0.85	0.87	0.188
W169PLPNS-5-2	5/16	1/8	0.97	0.75	0.250
W169PLPNS-5-4	5/16	1/4	0.97	0.94	0.250
W169PLPNS-6-4	3/8	1/4	1.01	0.94	0.312
W169PLPNS-6-6	3/8	3/8	1.01	1.01	0.312
W169PLPNS-6-8	3/8	1/2	1.01	1.27	0.312
W169PLPNS-8-6	1/2	3/8	1.15	1.00	0.375
W169PLPNS-8-8	1/2	1/2	1.15	1.27	0.375
W169PLPNS-5/32-4LT*	5/32	1/4-28	0.60	0.48	0.090

* SAE-LT Threads

C3PB Compact Elbow BSPT

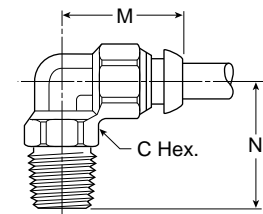

Part No.	Tube Size (mm)	Thread (BSPT)	C Hex. (mm)	M (mm)	N (mm)
C3PB4-1/8	4	1/8	14	18	21
C3PB6-1/8	6	1/8	14	20	21
C3PB6-1/4	6	1/4	14	20	21
C3PB8-1/8	8	1/8	14	22	23
C3PB8-1/4	8	1/4	14	22	23
C3PB10-1/4	10	1/4	17	28	26
C3PB10-3/8	10	3/8	17	28	26
C3PB12-3/8	12	3/8	17	30	27
C3PB12-1/2	12	1/2	17	30	31
C3PB14-3/8	14	3/8	20	34	30
C3PB14-1/2	14	1/2	20	34	33



C63SPK Adjustable Male Elbow BSPT

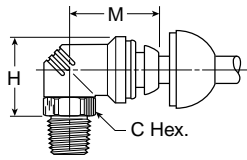

Part No.	Tube Size (mm)	Thread (BSPT)	C Hex. (mm)	H (mm)	M (mm)
C63SPK4-1/8	4	1/8	10	14.5	20.5
C63SPK4-1/4	4	1/4	14	14.5	20.5
C63SPK6-1/8	6	1/8	11	16.5	23.0
C63SPK6-1/4	6	1/4	14	16.0	23.0
C63SPK8-1/8	8	1/8	14	19.5	25.0
C63SPK8-1/4	8	1/4	14	18.5	25.0
C63SPK8-3/8	8	3/8	17	18.5	25.0
C63SPK10-1/4	10	1/4	17	23.0	31.0
C63SPK10-3/8	10	3/8	17	22.5	31.0
C63SPK10-1/2	10	1/2	22	24.0	31.0

W369PLX Male Elbow Swivel 90° (Composite Body)

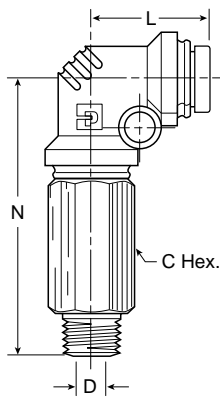

Part No.	Pipe		C Hex.	Mounting Hole Dia.	L	N	Flow Dia. D
	Tube Size (NPTF)	Thread					
W369PLX-2-2	1/8	1/8	7/16	0.13	0.70	1.74	.078
W369PLX-2-4	1/8	1/4	9/16	0.13	0.70	1.74	.078
W369PLX-3-2	3/16	1/8	7/16	0.17	0.76	1.88	.147
W369PLX-3-4	3/16	1/4	9/16	0.17	0.76	1.88	.147
W369PLX-3-6	3/16	3/8	11/16	0.17	0.76	1.88	.147
W369PLX-4-2	1/4	1/8	7/16	0.17	0.76	1.88	.172
W369PLX-4-4	1/4	1/4	9/16	0.17	0.76	1.88	.170
W369PLX-4-6	1/4	3/8	11/16	0.17	0.76	1.88	.172
369PLX-5/32-0	5/32	10-32	3/8	0.13	0.73	1.54	.094
W369PLX-5/32-2	5/32	1/8	7/16	0.13	0.73	1.54	.094
W369PLX-5/32-4	5/32	1/4	9/16	0.13	0.73	1.54	.094
W369PLX-5-2	5/16	1/8	9/16	0.17	0.84	1.99	.234
W369PLX-5-4	5/16	1/4	9/16	0.17	0.84	1.99	.234
W369PLX-5-6	5/16	3/8	11/16	0.17	0.84	1.99	.234
W369PLX-6-4	3/8	1/4	5/8	0.17	1.04	2.56	.234
W369PLX-6-6	3/8	3/8	11/16	0.17	1.04	2.56	.297
W369PLX-6-8	3/8	1/2	7/8	0.17	1.04	2.56	.297
W369PLX-8-4	1/2	1/4	3/4	0.17	1.03	2.80	.314
W369PLX-8-6	1/2	3/8	3/4	0.17	1.03	2.80	.344
W369PLX-8-8	1/2	1/2	7/8	0.17	1.03	2.80	.344

C63LPB Adjustable Extended Male Elbow BSPT

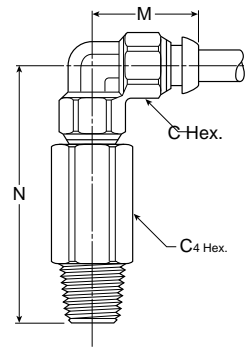

Part No.	Tube Size (mm)	Thread BSPT	C Hex. (mm)	C4 Hex. (mm)	M (mm)	N (mm)
C63LPB4-1/8	4	1/8	10	10	18	42.0
C63LPB4-1/4	4	1/4	10	14	18	46.0
C63LPB6-1/8	6	1/8	12	11	20	45.5
C63LPB6-1/4	6	1/4	12	14	20	49.5
C63LPB8-1/8	8	1/8	14	14	22	50.0
C63LPB8-1/4	8	1/4	14	14	22	52.5

C63LPK Adjustable Male Elbow BSPT

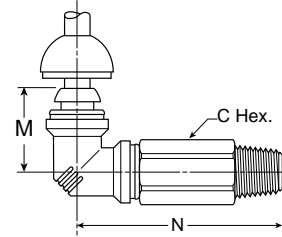

Part No.	Tube Size (mm)	Thread BSPT	C Hex. (mm)	M (mm)	N (mm)
C63LPK4-1/8	4	1/8	10	18.0	41.0
C63LPK4-1/4	4	1/4	14	18.0	45.0
C63LPK6-1/8	6	1/8	11	20.5	45.0
C63LPK6-1/4	6	1/4	14	20.5	49.0
C63LPK8-1/8	8	1/8	14	22.5	49.5
C63LPK8-1/4	8	1/4	14	22.5	52.0

T2ESPK Compact Plug-In Elbow

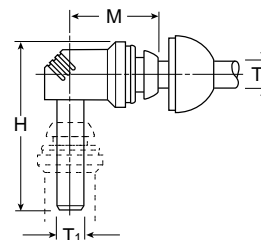

Part No.	Tube 1 Size (mm)	Tube 2 Size (mm)	H (mm)	M (mm)
T2ESPK4	4	4	20.5	31
T2ESPK6	6	6	23.0	36
T2ESPK4-6	4	6	23.0	33
T2ESPK8	8	8	25.0	38

F



370PL Female Elbow Swivel (Composite Body)

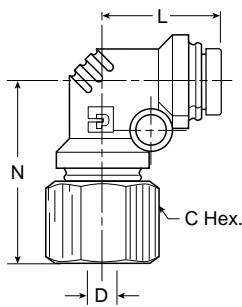

Part No.	Pipe				L	N	Flow Dia. D
	Tube Size	Thread (NPTF)	C Hex.	Mounting Hole Dia.			
370PL-2-2	1/8	1/8	9/16	0.13	0.71	1.01	0.078
370PL-5/32-2	5/32	1/8	9/16	0.13	0.73	1.01	0.094
370PL-5/32-4	5/32	1/4	3/4	0.13	0.73	1.23	0.094
370PL-4-10x32	1/4	10x32	7/16	0.17	0.76	1.02	0.159
370PL-4-2	1/4	1/8	9/16	0.17	0.76	1.07	0.174
370PL-4-4	1/4	1/4	3/4	0.17	0.76	1.29	0.174
370PL-5-4	5/16	1/4	3/4	0.17	0.84	1.37	0.234
370PL-6-4	3/8	1/4	3/4	0.17	1.04	1.57	0.297
370PL-8-6	1/2	3/8	7/8	0.17	1.03	1.57	0.344

W171PLP Male Run Tee Swivel (Nickle Plated)

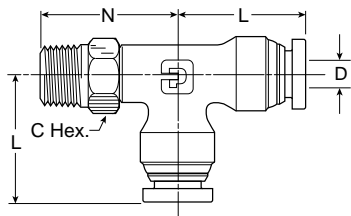

Part No.	Pipe				L	N	Flow Dia. D
	Tube Size	Thread (NPTF)	C Hex.	Mounting Hole Dia.			
W171PLP-2-2	1/8	1/8	7/16	0.74	0.92	0.094	
W171PLP-5/32-2	5/32	1/8	7/16	0.77	0.92	0.125	
W171PLP-4-2	1/4	1/8	7/16	0.85	0.92	0.188	
W171PLP-4-4	1/4	1/4	9/16	0.85	1.10	0.188	
W171PLP-4-6	1/4	3/8	11/16	0.85	1.24	0.188	
W171PLP-5-2	5/16	1/8	9/16	0.97	1.02	0.250	
W171PLP-5-4	5/16	1/4	9/16	0.97	1.24	0.250	
W171PLP-6-4	3/8	1/4	9/16	1.01	1.24	0.250	
W171PLP-6-6	3/8	3/8	11/16	1.01	1.24	0.250	
W171PLP-8-6	1/2	3/8	11/16	1.15	1.31	0.375	
W171PLP-8-8	1/2	1/2	7/8	1.15	1.52	0.375	

W371PL Male Run Tee Swivel (Composite Body)

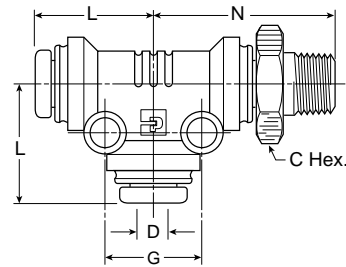

Part No.	Pipe				L	N	G	Flow Dia. D
	Tube Size	Thread (NPTF)	C Hex.	Mounting Hole Dia.				
W371PL-2-1	1/8	1/16	3/8	0.13	0.71	1.08	0.52	.078
W371PL-2-2	1/8	1/8	7/16	0.13	0.71	1.14	0.52	.078
W371PL-2-4	1/8	1/4	9/16	0.13	0.71	1.32	0.52	.078
371PL-2-10x32	1/8	10-32	3/8	0.13	0.71	0.94	0.52	.078
W371PL-3-2	3/16	1/8	7/16	0.17	0.76	1.20	0.64	.147
W371PL-3-4	3/16	1/4	9/16	0.17	0.76	1.43	0.64	.147
W371PL-5/32-2	5/32	1/8	7/16	0.13	0.71	1.14	0.52	.094
W371PL-5/32-4	5/32	1/4	9/16	0.13	0.71	1.32	0.52	.094
371PL5/32-10x32	5/32	10-32	3/8	0.13	0.71	0.94	0.52	.094
W371PL-4-1	1/4	1/16	7/16	0.17	0.76	1.20	0.64	.094
W371PL-4-2	1/4	1/8	7/16	0.17	0.76	1.20	0.64	.172
W371PL-4-4	1/4	1/4	9/16	0.17	0.76	1.38	0.64	.172
371PL-4-10x32	1/4	10-32	7/16	0.13	0.76	1.05	0.64	.094
W371PL-4-6	1/4	3/8	11/16	0.17	0.76	1.42	0.64	.172
W371PL-5-2	5/16	1/8	9/16	0.17	0.84	1.28	0.71	.234
W371PL-5-4	5/16	1/4	9/16	0.17	0.84	1.46	0.71	.234
W371PL-6-2	3/8	1/8	9/16	0.13	1.04	1.48	0.83	.234
W371PL-6-4	3/8	1/4	5/8	0.17	1.04	1.66	0.83	.297
W371PL-6-6	3/8	3/8	11/16	0.17	1.04	1.66	0.83	.297
W371PL-6-8	3/8	1/2	7/8	0.13	1.04	1.85	0.83	.297
W371PL-8-4	1/2	1/4	3/4	0.17	1.30	2.07	0.99	.314
W371PL-8-6	1/2	3/8	3/4	0.17	1.30	2.07	0.99	.344
W371PL-8-8	1/2	1/2	7/8	0.17	1.30	2.26	0.99	.344

PRL2BF4-K Male Run Tee Swivel BSPP (Composite Body)

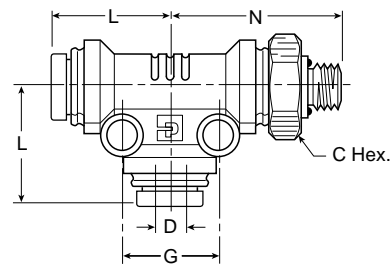

Part No.	Pipe				L	N	G	Flow Dia. D
	Tube Size	Thread (BSPP)	C Hex.	Mounting Hole Dia.				
3-1/4PLR2BF4-K	3/16	1/4-19	3/4	0.17	0.76	1.31	0.64	0.147
4-1/8PLR2BF4-K	1/4	1/8-28	11/16	0.17	0.76	1.06	0.64	0.177
4-1/4PLR2BF4-K	1/4	1/4-19	3/4	0.17	0.76	1.31	0.64	0.172
6-1/4PLR2BF4-K	3/8	1/4-19	3/4	0.17	1.04	1.56	0.83	0.296
6-3/8PLR2BF4-K	3/8	3/8-19	7/8	0.17	1.04	1.68	0.83	0.296
8-3/8PLR2BF4-K	1/2	3/8-19	7/8	0.17	1.30	1.90	0.99	0.344
8-1/2PLR2BF4-K	1/2	1/2-19	1-1/16	0.17	1.30	2.05	0.99	0.344



R63PB Swivel Male Run Tee BSPT

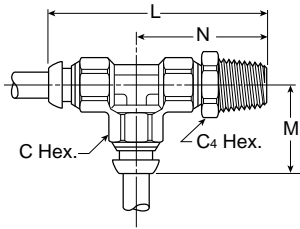

Part No.	Tube Size (mm)	Thread BSPT	C Hex. (mm)	C4 Hex. (mm)	L (mm)	M (mm)	N (mm)
R63PB4-1/8	4	1/8	10	10	44.5	18	26.5
R63PB4-1/4	4	1/4	10	14	48.0	18	30.0
R63PB6-1/8	6	1/8	12	11	48.0	20	28.0
R63PB6-1/4	6	1/4	12	14	51.0	20	31.0
R63PB8-1/8	8	1/8	14	14	52.0	22	30.0
R63PB8-1/4	8	1/4	14	14	55.0	22	33.0
R63PB8-3/8	8	3/8	14	17	56.5	22	34.5
R63PB10-1/4	10	1/4	17	17	68.0	28	40.0
R63PB10-3/8	10	3/8	17	17	67.0	28	39.0
R63PB12-1/4	12	1/4	22	19	72.0	30	42.0
R63PB12-3/8	12	3/8	22	19	71.0	30	41.0
R63PB12-1/2	12	1/2	22	22	74.5	30	44.5
R63PB14-3/8	14	3/8	25	22	80.0	34	46.0
R63PB14-1/2	14	1/2	25	22	82.5	34	48.5

R64PB Swivel Male Branch Run Tee BSPP

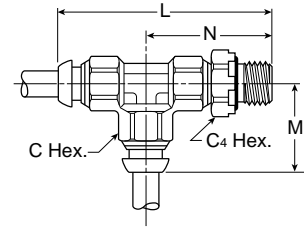

Part No.	Tube Size (mm)	Thread BSPT	C Hex. (mm)	C4 Hex. (mm)	L (mm)	M (mm)	N (mm)
R64PB4-1/8	4	1/8	10	14	6	44.5	18
R64PB4-1/4	4	1/4	10	19	9	49.5	18
R64PB6-1/8	6	1/8	12	14	6	50.0	20
R64PB6-1/4	6	1/4	12	19	9	53.0	20
R64PB8-1/8	8	1/8	14	14	6	52.0	22
R64PB8-1/4	8	1/4	14	19	9	57.0	22
R64PB8-3/8	8	3/8	14	22	9	58.0	22
R64PB10-1/4	10	1/4	17	19	9	67.0	28
R64PB10-3/8	10	3/8	17	22	9	68.0	28
R64PB12-1/4	12	1/4	22	19	9	71.0	30
R64PB12-3/8	12	3/8	22	22	9	72.0	30
R64PB14-3/8	14	3/8	25	22	9	80.0	34
R64PB14-1/2	14	1/2	25	27	12	84.5	34

R63PK Adjustable Male Run Tee BSPT

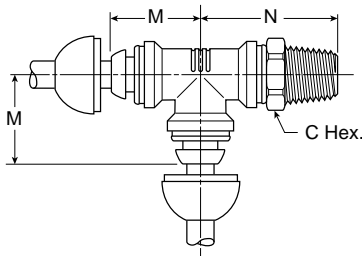

Part No.	Tube Size (mm)	Thread BSPT	C Hex. (mm)	M (mm)	N (mm)
R63PK4-1/8	4	1/8	10	18.0	25.5
R63PK4-1/4	4	1/4	14	18.0	29.0
R63PK6-1/8	6	1/8	11	20.5	27.0
R63PK6-1/4	6	1/4	14	20.5	30.5
R63PK8-1/8	8	1/8	14	22.5	29.5
R63PK8-1/4	8	1/4	14	22.5	32.5
R63PK8-3/8	8	3/8	17	22.5	34.0
R63PK10-1/4	10	1/4	17	28.5	40.0
R63PK10-3/8	10	3/8	17	28.5	39.0
R63PK12-1/4	12	1/4	19	30.0	41.5
R63PK12-3/8	12	3/8	19	30.0	41.0
R63PK12-1/2	12	1/2	22	30.0	44.5
R63PK14-3/8	14	3/8	22	33.5	45.5
R63PK14-1/2	14	1/2	22	33.5	48.0

R64PK Adjustable Male Run Tee BSPP

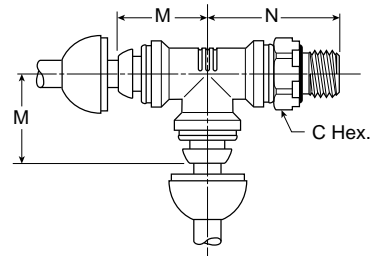

Part No.	Tube Size (mm)	Thread BSPT	C Hex. (mm)	M (mm)	N (mm)
R64PK4-1/8	4	1/8	14	18.0	25.5
R64PK4-1/4	4	1/4	19	18.0	30.5
R64PK6-1/8	6	1/8	14	20.5	27.0
R64PK6-1/4	6	1/4	19	20.5	32.0
R64PK8-1/8	8	1/8	14	22.5	29.0
R64PK8-1/4	8	1/4	19	22.5	34.0
R64PK8-3/8	8	3/8	22	22.5	35.0
R64PK10-1/4	10	1/4	19	28.5	39.0
R64PK10-3/8	10	3/8	22	28.5	40.0
R64PK12-1/4	12	1/4	19	30.0	40.5
R64PK12-3/8	12	3/8	22	30.0	41.5
R64PK14-3/8	14	3/8	22	33.5	45.0
R64PK14-1/2	14	1/2	27	33.5	49.5

F



**R68PB Adjustable Male Run Tee
Metric Straight Thread**

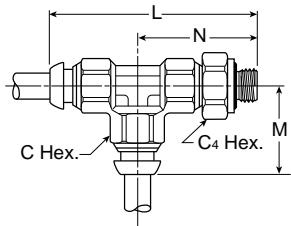

Part No.	Tube Size (mm)	Thread BSPT	C Hex. (mm)	C4 Hex. (mm)	L (mm)	M (mm)	N (mm)
R68PB4M3	4	M3x0.5	10	10	41.0	18	23.0
R68PB4M5	4	M5x0.8	10	10	42.5	18	24.5
R68PB6M5	6	M5x0.8	12	11	45.5	20	25.5

**R68PK Adjustable Male Run Tee
Metric Straight Thread**

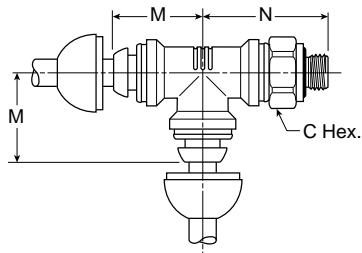

Part No.	Tube Size (mm)	Thread BSPT	C Hex. (mm)	M (mm)	N (mm)
R68PK4M3	4	M3x0.5	10	18.0	22.0
R68PK4M5	4	M5x0.8	10	18.0	23.5
R68PK6M5	6	M5x0.8	11	20.5	25.0
R68PK8M12	8	M12x1.5	17	22.5	35.0
R68PK8M16	8	M16x1.5	22	22.5	35.0
R68PK8M22	8	M22x1.5	27	22.5	39.0

T2JJPK Plug-In Run Tee

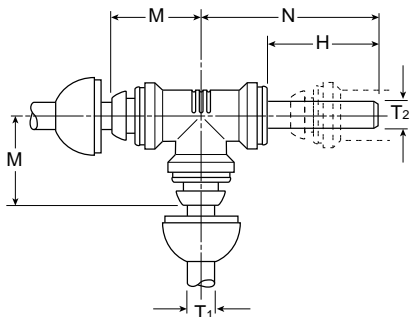

Part No.	Tube 1 Size (mm)	Tube 2 Size (mm)	Mounting Hole Dia. (mm)	H (mm)	M (mm)	N (mm)
T2JJPK4	4	4	3.2	19.5	18.0	33.5
T2JJPK6	6	6	4.2	21.0	20.5	36.5
T2JJPK8	8	8	4.2	22.0	22.5	39.5

W172PLP Male Branch Tee Swivel (Nickle Plated)

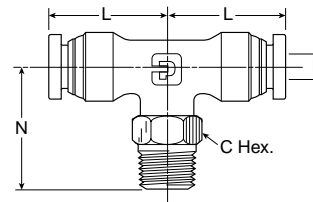

Part No.	Tube Size	Pipe Thread NPT	C Hex.	L	N	Flow Dia. D
W172PLP-2-2	1/8	1/8	7/16	0.74	0.92	0.094
W172PLP-3-2	3/16	1/8	7/16	0.82	0.92	0.156
W172PLP-5/32-2	5/32	1/8	7/16	0.77	0.92	0.125
W172PLP-4-2	1/4	1/8	7/16	0.85	0.92	0.188
W172PLP-4-4	1/4	1/4	9/16	0.85	1.10	0.188
W172PLP-4-6	1/4	3/8	11/16	0.85	1.10	0.188
W172PLP-5-2	5/16	1/8	9/16	0.97	1.02	0.250
W172PLP-5-4	5/16	1/4	9/16	0.97	1.24	0.250
W172PLP-6-4	3/8	1/4	9/16	1.01	1.24	0.250
W172PLP-6-6	3/8	3/8	11/16	1.01	1.24	0.250
W172PLP-8-4	1/2	1/4	9/16	1.15	1.30	0.375
W172PLP-8-6	1/2	3/8	11/16	1.15	1.31	0.375
W172PLP-8-8	1/2	1/2	7/8	1.15	1.52	0.375

W372PL Male Branch Tee Swivel (Composite Body)

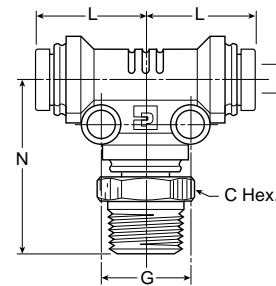

Part No.	Tube Size	Pipe Thread (NPTF)	C Hex.	Mounting Hole Dia.	L	N	G	Flow Dia. D
W372PL-2-1	1/8	1/16	3/8	0.13	0.71	1.08	0.52	0.078
W372PL-2-2	1/8	1/8	7/16	0.13	0.71	1.14	0.52	0.078
W372PL-2-4	1/8	1/4	9/16	0.13	0.71	1.32	0.52	0.078
372PL-2-10X32	1/8	10-32	3/8	0.13	0.71	.94	0.52	0.078
W372PL-3-2	3/16	1/8	7/16	0.17	0.76	1.20	0.64	0.147
W372PL-3-4	3/16	1/4	9/16	0.17	0.76	1.40	0.64	0.147
W372PL-5/32-2	5/32	1/8	7/16	0.13	0.71	1.14	0.52	0.094
W372PL-5/32-4	5/32	1/4	9/16	0.13	0.68	1.32	0.52	0.094
372PL5/32-10x32	5/32	10-32	3/8	0.13	0.70	.94	0.52	0.094
W372PL-4-1	1/4	1/16	7/16	0.17	0.76	1.20	0.64	0.094
W372PL-4-2	1/4	1/8	7/16	0.17	0.76	1.20	0.64	0.172
W372PL-4-4	1/4	1/4	9/16	0.17	0.76	1.38	0.64	0.172
372PL-4-10x32	1/4	10-32	7/16	0.17	0.76	1.05	0.64	0.094
W372PL-4-6	1/4	3/8	11/16	0.17	0.76	1.42	0.64	0.172
W372PL-5-2	5/16	1/8	9/16	0.17	0.84	1.23	0.71	0.234
W372PL-5-4	5/16	1/4	9/16	0.17	0.84	1.23	0.71	0.234
W372PL-6-2	3/8	1/8	9/16	0.17	1.04	1.48	0.83	0.234
W372PL-6-4	3/8	1/4	5/8	0.17	1.04	1.66	0.83	0.297
W372PL-6-6	3/8	3/8	11/16	0.17	1.04	1.66	0.83	0.297
W372PL-6-8	3/8	1/2	7/8	0.17	1.04	1.85	0.83	0.297
W372PL-8-4	1/2	1/4	3/4	0.17	1.30	2.07	0.99	0.314
W372PL-8-6	1/2	3/8	3/4	0.17	1.30	2.07	0.99	0.344
W372PL-8-8	1/2	1/2	7/8	0.17	1.30	2.26	0.99	0.344



PLS2BF4-K Male Branch Tee Swivel BSPP (Composite Body)

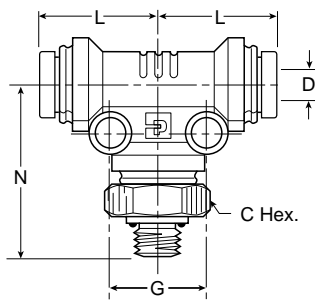

Part No.	Tube Size	Thread (BSPP)	C Hex.	Mounting Hole Dia.	L	N	G	Flow Dia. D
3-1/8PLS2BF4-K	3/16	1/8-28	11/16	0.17	0.76	1.05	0.64	0.147
3-1/4PLS2BF4-K	3/16	1/4-19	3/4	0.17	0.76	1.31	0.64	0.147
4-1/8PLS2BF4-K	1/4	1/8-28	11/16	0.17	0.76	1.06	0.64	0.177
4-1/4PLS2BF4-K	1/4	1/4-19	3/4	0.17	0.76	1.31	0.64	0.172
6-1/4PLS2BF4-K	3/8	1/4-19	3/4	0.17	1.04	1.56	0.83	0.296
6-3/8PLS2BF4-K	3/8	3/8-19	7/8	0.17	1.04	1.68	0.83	0.296
6-1/2PLS2BF4-K	3/8	1/2-14	1-1/16	0.17	1.04	1.83	0.83	0.297
8-3/8PLS2BF4-K	1/2	3/8-19	7/8	0.17	1.30	1.90	0.99	0.344

S63PK Adjustable Male Branch Tee BSPT

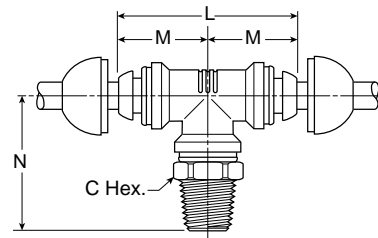

Part No.	Tube Size (mm)	Thread BSPT	C Hex. (mm)	M (mm)	N (mm)
S63PK4-1/8	4	1/8	10	18.0	25.5
S63PK4-1/4	4	1/4	14	18.0	29.0
S63PK6-1/8	6	1/8	11	18.0	29.0
S63PK6-1/4	6	1/4	14	20.5	30.5
S63PK8-1/8	8	1/8	14	22.5	29.5
S63PK8-1/4	8	1/4	14	22.5	32.5
S63PK8-3/8	8	3/8	17	22.5	34.0
S63PK10-1/4	10	1/4	17	28.5	40.0
S63PK10-3/8	10	3/8	17	28.5	39.0
S63PK12-1/4	12	1/4	19	30.0	41.5
S63PK12-3/8	12	3/8	19	30.0	41.0
S63PK12-1/2	12	1/2	22	30.0	44.5
S63PK14-3/8	14	3/8	22	33.5	45.5
S63PK14-1/2	14	1/2	22	33.5	48.0

S63PB Swivel Male Branch Tee BSPT

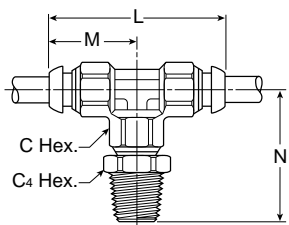

Part No.	Tube Size (mm)	Thread BSPT	C Hex. (mm)	C4 Hex. (mm)	L (mm)	M (mm)	N (mm)
S63PB4-1/8	4	1/8	10	10	36	18	26.5
S63PB4-1/4	4	1/4	10	14	36	18	30.0
S63PB6-1/8	6	1/8	12	11	40	20	28.0
S63PB6-1/4	6	1/4	12	14	40	20	31.0
S63PB8-1/8	8	1/8	14	14	44	22	30.0
S63PB8-1/4	8	1/4	14	14	44	22	33.0
S63PB8-3/8	8	3/8	14	17	44	22	34.5
S63PB10-1/4	10	1/4	17	17	56	28	40.0
S63PB10-3/8	10	3/8	17	17	56	28	39.0
S63PB12-1/4	12	1/4	22	19	60	30	42.0
S63PB12-3/8	12	3/8	22	19	60	30	41.0
S63PB12-1/2	12	1/2	22	22	60	30	44.5
S63PB14-3/8	14	3/8	25	22	68	34	46.0
S63PB14-1/2	14	1/2	25	22	68	34	48.5

S64PB Swivel Male Branch Tee BSPT

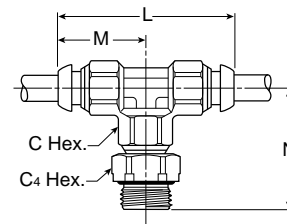

Part No.	Tube Size (mm)	Thread BSPT	C Hex. (mm)	C4 Hex. (mm)	L (mm)	M (mm)	N (mm)
S64PB4-1/8	4	1/8	10	14	36	18	26.5
S64PB4-1/4	4	1/4	10	19	36	18	31.5
S64PB6-1/8	6	1/8	12	14	40	20	30.0
S64PB6-1/4	6	1/4	12	19	40	20	33.0
S64PB8-1/8	8	1/8	14	14	44	22	30.0
S64PB8-1/4	8	1/4	14	19	44	22	35.0
S64PB8-3/8	8	3/8	14	22	44	22	36.0
S64PB10-1/4	10	1/4	17	19	56	28	39.0
S64PB10-3/8	10	3/8	17	22	56	28	40.0
S64PB12-1/4	12	1/4	22	19	60	30	41.0
S64PB12-3/8	12	3/8	22	22	60	30	42.0
S64PB14-3/8	14	3/8	25	22	68	34	46.0
S64PB14-1/2	14	1/2	25	27	68	34	50.5

F



S64PK Adjustable Male Branch Tee BSPP

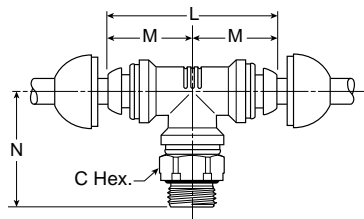

Part No.	Tube Size (mm)	Thread BSPT	C Hex. (mm)	M (mm)	N (mm)
S64PK4-1/8	4	1/8	14	18.0	25.5
S64PK4-1/4	4	1/4	19	18.0	30.5
S64PK6-1/8	6	1/8	14	20.5	27.0
S64PK6-1/4	6	1/4	19	20.5	32.0
S64PK8-1/8	8	1/8	14	22.5	29.0
S64PK8-1/4	8	1/4	19	22.5	34.0
S64PK8-3/8	8	3/8	22	22.5	35.0
S64PK10-1/4	10	1/4	19	28.5	39.0
S64PK10-3/8	10	3/8	22	28.5	40.0
S64PK12-1/4	12	1/4	19	30.0	40.5
S64PK12-3/8	12	3/8	22	30.0	41.5
S64PK14-3/8	14	3/8	22	33.5	45.0
S64PK14-1/2	14	1/2	27	33.5	49.5

S68PB Adjustable Male Branch Tee Metric Straight Thread

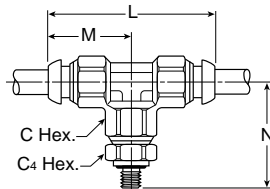

Part No.	Tube Size (mm)	Thread BSPT	C Hex. (mm)	C4 Hex. (mm)	L (mm)	M (mm)	N (mm)
S68PB4M3	4	M3x0.5	10	10	36	18	23.0
S68PB4M5	4	M5x0.8	10	10	36	18	24.5
S68PB6M5	6	M5x0.8	12	11	40	20	25.5

S68PK Adjustable Male Branch Tee Metric Straight Thread

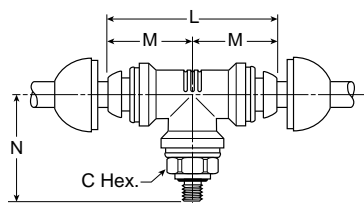

Part No.	Tube Size (mm)	Thread BSPT	C Hex. (mm)	M (mm)	N (mm)
S68PK4M3	4	M3x0.5	10	18.0	22.0
S68PK4M5	4	M5x0.8	10	18.0	23.5
S68PK6M5	6	M5x0.8	11	20.5	25.0
S68PK8M12	8	M12x1.5	17	22.5	35.0
S68PK8M16	8	M16x1.5	22	22.5	35.0
S68PK8M22	8	M22x1.5	27	22.5	39.0

T2JPK Plug-In Branch Tee

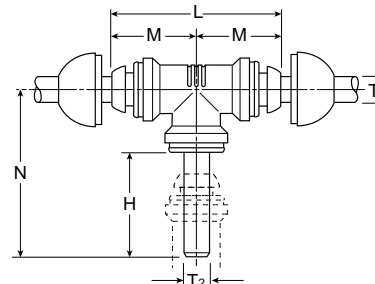

Part No.	Tube 1 Size (mm)	Tube 2 Size (mm)	Mounting Hole Dia. (mm)	H (mm)	M (mm)	N (mm)
T2JPK4	4	4	3.2	19.5	18.0	33.5
T2JPK6	6	6	4.2	21.0	20.5	36.5
T2JPK8	8	8	4.2	22.0	22.5	39.5

377PL Female Branch Tee Swivel (Composite Body)

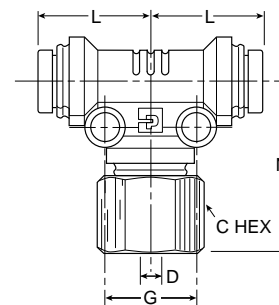

Part No.	Pipe Tube Thread Size (NPTF)	Thread	C Hex.	Mounting Hole Dia.	L	N	G	Flow Dia. D
377PL-2-2	1/8	1/8	9/16	0.17	0.71	1.01	0.52	0.078
377PL-5/32-2	5/32	1/8	9/16	0.13	0.71	1.01	0.52	0.094
377PL-5/32-4	5/32	1/4	3/4	0.13	0.71	1.23	0.52	0.094
377PL-4-2	1/4	1/8	9/16	0.17	0.76	1.07	0.64	0.176
377PL-4-4	1/4	1/4	3/4	0.17	0.76	1.29	0.64	0.176
377PL-5-4	5/16	1/4	3/4	0.17	0.84	1.37	0.71	0.234
377PL-6-4	3/8	1/4	3/4	0.17	1.04	1.57	0.83	0.298
377PL-8-6	1/2	3/8	7/8	0.17	1.30	1.84	0.99	0.344

362PL Union Y Connector (Composite Body)

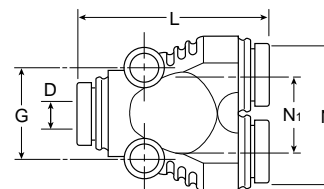

Part No.	Tube Size	Mounting Hole Dia.	L	N	N1	G	Flow Dia. D
362PL-2	1/8	0.13	1.37	0.92	0.41	0.57	0.130
362PL-5/32	5/32	0.13	1.36	0.92	0.41	0.57	0.160
362PL-3	3/16	0.17	1.49	1.13	0.53	0.67	0.200
362PL-4	1/4	0.17	1.49	1.13	0.53	0.67	0.260
362PL-5	5/16	0.17	1.46	1.21	0.54	0.72	0.320
362PL-6	3/8	0.17	1.88	1.53	0.71	0.76	0.380



WYJ6PK Adjustable Male Bulkhead Y Connector

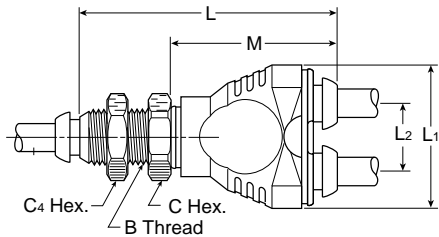

Part No.	Tube		C Hex. (mm)	C4 Hex. (mm)	L (mm)	L1 (mm)	L2 (mm)	M (mm)
	Size (mm)	Thread BSPT						
WYJ6PK4	4	M11x0.75	14	16	46	22	11.0	27
WYJ6PK6	6	M13x1	17	17	54	30	13.5	35
WYJ6PK8	8	M15x1.25	19	19	64	30	13.5	35

YJPK Union Y Connector

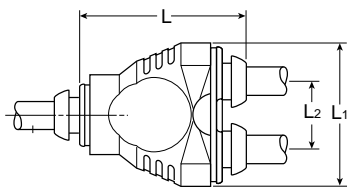

Part No.	Tube Size (mm)	L (mm)	L1 (mm)	L2 (mm)
YJPK4*	4	31	22	11.0
YJPK6*	6	40	30	13.5
YJPK8*	8	40	30	13.5

* Fittings not suitable for use with protective cap.

YJPK Unequal Union Y Connector

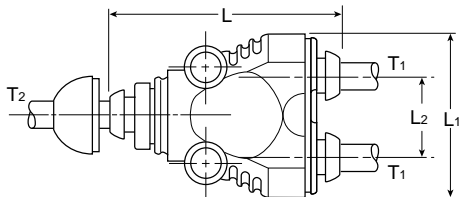

Part No.	Tube		Hole Dia. (mm)	L (mm)	L1 (mm)	L2 (mm)
	Size (mm)	Size (mm)				
YJPK4-4-6	4	6	4.2	40	30	13.5
YJPK6-6-8	6	8	4.2	40	30	13.5
YJPK8-8-10	8	10	4.2	40	31	13.6

YJ5PK Union Double Y Connector

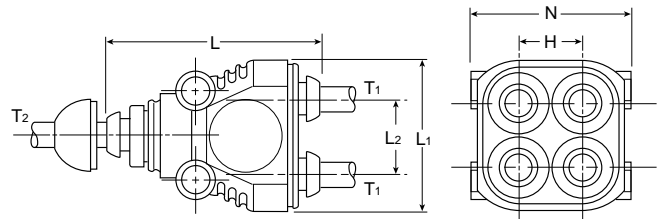

Part No.	Tube		Hole Dia. (mm)	H (mm)	L (mm)	N (mm)
	Size (mm)	Size (mm)				
YJ5PK6-4	6	4	4.2	22.5	38	9.5
YJ5PK4	4	4	3.2	22.5	35	9.5

YJ2PK Plug-In Y Connector

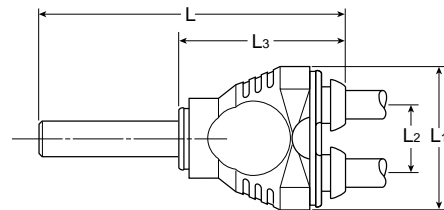

Part No.	Tube Size (mm)	L (mm)	L1 (mm)	L2 (mm)	L3 (mm)
YJ2PK4*	4	46.5	22	11.0	11.0
YJ2PK6*	6	56.0	30	13.5	13.5
YJ2PK8*	8	57.0	30	13.5	13.5

* Fittings not suitable for use with protective cap.

YJ52PK Union Double Y Connector

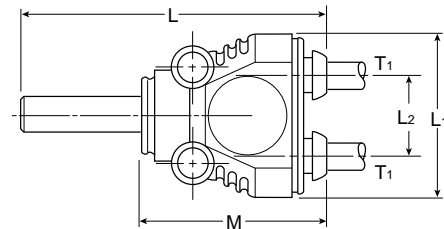

Part No.	Tube		Hole Dia. (mm)	L (mm)	L1 (mm)	L2 (mm)	m (mm)
	Size (mm)	Size (mm)					
YJ52PK6-4	6	4	3.2	52	22.5	9.5	31

F

W368PL Union Y Male Connector

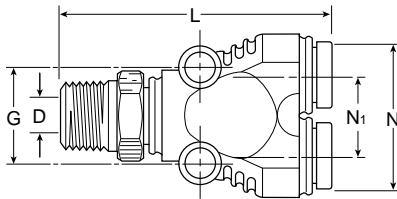

Part No.	Tube Size	Pipe Size	Mounting					Flow Dia. D
			Hole Dia. (mm)	G	L	N	N ₁	
W368PL-2-2	1/8	1/8	0.13	0.57	1.81	0.92	0.41	0.080
W368PL-2-4	1/8	1/4	0.13	0.57	1.98	0.92	0.41	0.080
368PL5/32-10x32	5/32	10-32	0.13	0.57	1.60	0.92	0.41	0.090
W368PL-5/32-2	5/32	1/8	0.13	0.57	1.80	0.92	0.41	0.090
W368PL-5/32-4	5/32	1/4	0.13	0.57	1.98	0.92	0.41	0.090
368PL-3-10x32	3/16	10-32	0.17	0.67	1.77	1.13	0.53	0.094
W368PL-3-2	3/16	1/8	0.17	0.67	1.92	1.13	0.53	0.150
W368PL-3-4	3/16	1/4	0.17	0.67	2.16	1.13	0.53	0.150
W368PL-3-6	3/16	3/8	0.17	0.67	2.16	1.13	0.53	0.147
368PL-4-10x32	1/4	10-32	0.17	0.67	1.78	1.13	0.53	0.090
W368PL-4-2	1/4	1/8	0.17	0.67	1.93	1.13	0.53	0.172
W368PL-4-4	1/4	1/4	0.17	0.67	2.11	1.13	0.53	0.170
W368PL-4-6	1/4	3/8	0.17	0.67	2.15	1.13	0.53	0.170
W368PL-5-2	5/16	1/8	0.17	0.72	1.87	1.20	0.54	0.230
W368PL-5-4	5/16	1/4	0.17	0.72	2.10	1.20	0.54	0.230
W368PL-5-6	5/16	3/8	0.17	0.72	2.10	1.20	0.54	0.234
W368PL-6-4	3/8	1/4	0.17	0.76	2.50	1.53	0.71	0.300
W368PL-6-6	3/8	3/8	0.17	0.76	2.50	1.53	0.71	0.300

YJ63PK Adjustable Male Y Connector BSPT

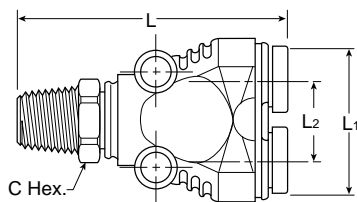

Part No.	Tube Size (mm)	Thread BSPT	C Hex. (mm)	L (mm)	L ₁ (mm)	L ₂ (mm)
YJ63PK4-1/8*	4	1/8	10	38.5	22	11.0
YJ63PK4-1/4*	4	1/4	14	42.0	22	11.0
YJ63PK6-1/8*	6	1/8	11	51.5	30	13.5
YJ63PK6-1/4*	6	1/4	14	50.0	30	13.5
YJ63PK8-1/8*	8	1/8	14	47.0	30	13.5
YJ63PK8-1/4*	8	1/4	14	50.0	30	13.5

*Fittings not suitable for use with protective cap.

YJ563PK Union Double Y Connector Adjustable Male BSPT

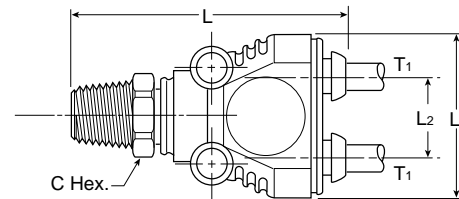

Part No.	Tube Size (mm)	Thread BSPT	Mounting Hole Dia. (mm)	C Hex. (mm)	L (mm)	L ₁ (mm)	L ₂ (mm)
YJ563PK4-1/8	4	1/8	3.2	10	42.5	22.5	9.5
YJ563PK4-1/4	4	1/4	3.2	14	46.0	22.5	9.5

YJ64PK Adjustable Male Y Connector BSPP

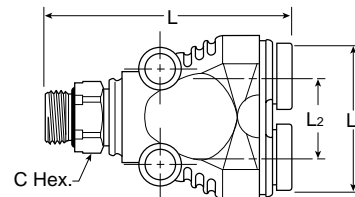

Part No.	Tube Size (mm)	Thread BSPP	C Hex. (mm)	L (mm)	L ₁ (mm)	L ₂ (mm)
YJ64PK4-1/8*	4	1/8	14	38.5	22	11.0
YJ64PK4-1/4*	4	1/4	19	43.5	22	11.0
YJ64PK6-1/8*	6	1/8	14	46.5	30	13.5
YJ64PK6-1/4*	6	1/4	19	51.5	30	13.5
YJ64PK8-1/8*	8	1/8	14	46.5	30	13.5
YJ64PK8-1/4*	8	1/4	19	51.5	30	13.5

*Fittings not suitable for use with protective cap.

YJ564PK Union Double Y Connector Adjustable Male BSPP

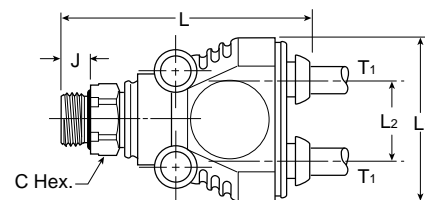

Part No.	Tube Size (mm)	Thread BSPP	Mounting Hole Dia. (mm)	C Hex. (mm)	J (mm)	L (mm)	L ₁ (mm)	L ₂ (mm)
YJ564PK4-1/8	4	1/8	3.2	14	6	42.5	22.5	9.5
YJ564PK4-1/4	4	1/4	3.2	19	9	47.5	22.5	9.5



CORPB Single Banjo, Body Only

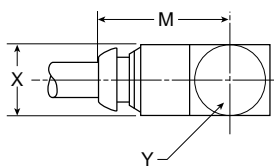

Part No.	Tube Size (mm)	Part No. Single Bolt	Part No. Stacking Bolt	M (mm)	X (mm)	Y (mm)
CORPB4-5	4	SC8UM5-4	SC8UDM5-4	19.0	10	10
CORPB4-10	4	SC4U1/8-4	SC4UD1/8-4	22.5	14	14
CORPB6-10	6	SC4U1/8-4	SC4UD1/8-4	23.0	14	14
CORPB6-13	6	SC4U1/4-6	SC4UD1/4-6	24.5	14	17
CORPB8-10	8	SC4U1/8-4	SC4UD1/8-4	24.0	14	14
CORPB8-13	8	SC4U1/4-6	SC4UD1/4-6	25.5	14	17
CORPB10-17	10	SC4U3/8-10	SC4UD3/8-10	32.0	17	22

CORPB Double Banjo, Body Only

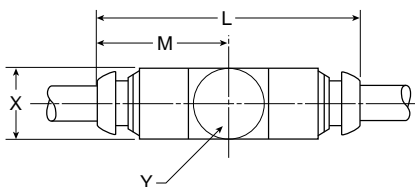

Part No.	Tube Size (mm)	Part No. Single Bolt	Part No. Stacking Bolt	L (mm)	M (mm)	X (mm)	Y (mm)
CORPB4D5	4	SC8UM5-4	SC8UDM5-4	38	19.0	10	10
CORPB4D10	4	SC4U1/8-4	SC4UD1/8-4	45	22.5	14	14
CORPB6D10	6	SC4U1/8-4	SC4UD1/8-4	46	23.0	14	14
CORPB6D13	6	SC4U1/4-6	SC4UD1/4-6	49	24.5	14	17
CORPB8D10	8	SC4U1/8-4	SC4UD1/8-4	48	24.0	14	14

COR8PB / COR4PB Single Banjo Assembled

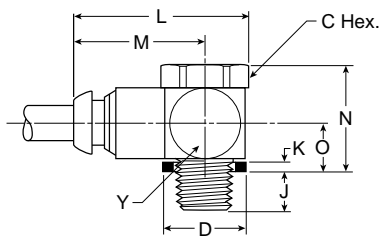

Part No.	Tube Size (mm)	Thread BSP	C Hex. (mm)	D (mm)	J (mm)	K (mm)	L (mm)	M (mm)	N (mm)	O (mm)	Y (mm)
COR8PB4M5	4	M5x0.8	8	8.2	4.5	1.0	24.0	19.0	13.5	6.0	10
COR4PB4-1/8	4	1/8	14	14.4	6.0	1.5	29.5	22.5	19.5	8.5	14
COR4PB6-1/8	6	1/8	14	14.4	6.0	1.5	30.0	23.0	19.5	8.5	14
COR4PB6-1/4	6	1/4	17	18.4	9.0	2.0	33.0	24.5	21.0	9.0	17
COR4PB8-1/8	8	1/8	14	14.4	6.0	1.5	31.0	34.0	19.5	8.5	14
COR4PB8-1/4	8	1/4	17	18.4	9.0	2.0	34.0	25.5	21.0	9.0	17
COR4PB10-3/8	10	3/8	22	21.6	9.0	2.5	43.0	32.0	25.5	11.0	22

These parts are delivered complete with sealing washer.

COR8PB / COR4PB Double Banjo Assembled

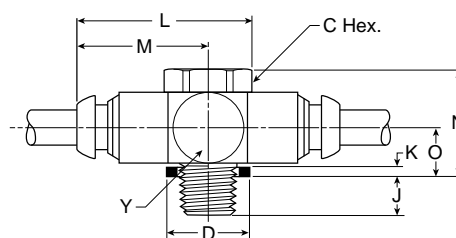

Part No.	Tube Size (mm)	Thread BSP	C Hex. (mm)	D (mm)	J (mm)	K (mm)	L (mm)	M (mm)	N (mm)	O (mm)	Y (mm)
COR8PB4DM5	4	M5x0.8	8	8.2	4.5	1.0	38	19.0	13.5	6.0	10
COR4PB4D1/8	4	1/8	14	14.4	6.0	1.5	45	22.5	19.5	8.5	14
COR4PB6D1/8	6	1/8	14	14.4	6.0	1.5	46	23.0	19.5	8.5	14
COR4PB6D1/4	6	1/4	17	18.4	9.0	2.0	49	24.5	21.0	9.0	17
COR4PB8D1/8	8	1/8	14	14.4	6.0	1.5	48	24.0	19.5	8.5	14

These parts are delivered complete with sealing washer.

SC8U / SC4U Single Banjo Bolt with Seals BSP

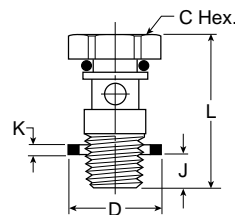

Part No.	Thread BSP	C Hex. (mm)	D (mm)	J (mm)	K (mm)	L (mm)
SC8UM5-4	M5x0.8	8	8.2	4.5	1.0	18.5
SC4U1/8-4	1/8	14	14.4	6.0	1.5	25.5
SC4U1/4-6	1/4	17	18.4	9.0	2.0	30.0
SC4U3/8-10	3/8	22	21.6	9.0	2.5	34.5

SC8UD / SC4UD Single Banjo Bolt with Seals BSP

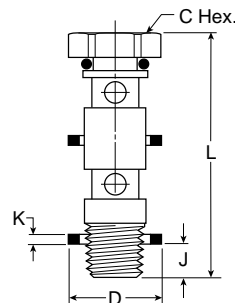

Part No.	Thread BSP	C Hex. (mm)	D (mm)	J (mm)	K (mm)	L (mm)
SC8UDM5-4	M5x0.8	8	8.2	4.5	1.0	29.5
SC4UD1/8-4	1/8	14	14.4	6.0	1.5	41.0
SC4UD1/4-6	1/4	17	18.4	9.0	2.0	46.0

F



J5PK Multiple Tee

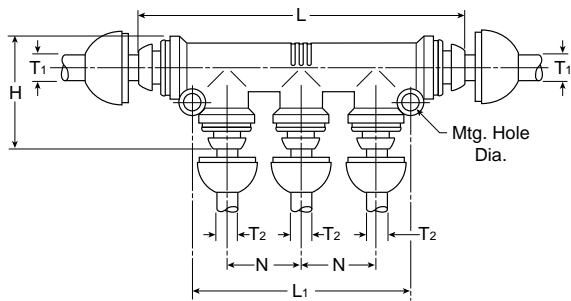

Part No.	Tube 1 Size (mm)	Tube 2 Size (mm)	Mounting Hole (mm)	H (mm)	L (mm)	L1 (mm)	N (mm)
J5PK6-4	6	4	4.2	27	78	52	18
J5PK8-4	8	4	4.2	28	80	52	18
J5PK8-6	8	6	4.2	30	80	52	18
J5PK10-6	10	6	4.2	33	90	52	18

J6PK Multiple Tee

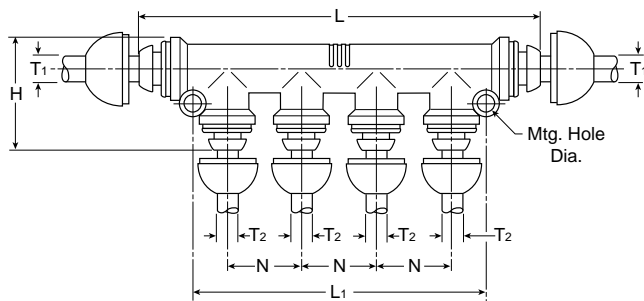

Part No.	Tube 1 Size (mm)	Tube 2 Size (mm)	Mounting Hole (mm)	H (mm)	L (mm)	L1 (mm)	N (mm)
J6PK6-4	6	4	4.4	27	96	70	18
J6PK8-4	8	4	4.4	28	98	70	18
J6PK8-6	8	6	4.4	30	98	70	18
J6PK10-6	10	6	4.4	33	108	70	18

J663PK Adjustable Male Multiple Tee BSPT

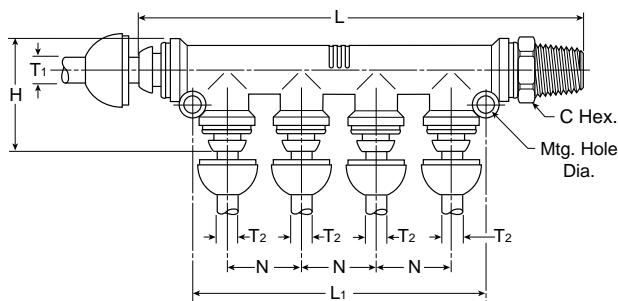

Part No.	Tube 1 Size (mm)	Tube 2 Size (mm)	Mtg. Hole (mm)	C Thread BSPT	Hex. (mm)	H (mm)	L (mm)	L1 (mm)	N (mm)
J663PK6-4-1/4	6	4	4.4	1/4	14	27	106.5	70	18

639PL Plug

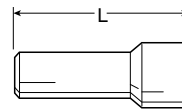

Part No.	Tube 1 Size (mm)	L (mm)
639PL-2	1/8	1.30
639PL-5/32	5/32	1.30
639PL-4	1/4	1.34
639PL-5	5/16	1.28
639PL-6	3/8	1.50
639PL-8	1/2	1.59

FNPB Plug

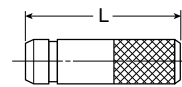

Part No.	Tube 1 Size (mm)	L (mm)
FNPB4	4	27
FNPB6	6	27
FNPB8	8	30
FNPB10	10	30
FNPB12	12	35
FNPB14	14	36

FNPK Plug

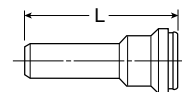

Part No.	Tube 1 Size (mm)	L (mm)
FNPK4	4	34.5
FNPK6	6	35.0
FNPK8	8	35.0
FNPK10	10	42.0
FNPK12	12	41.0
FNPK14	14	40.0



T23FPK Tube End Male Adaptor BSPT

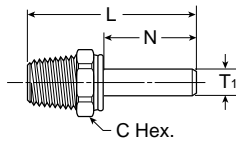

Part No.	Tube Size (mm)	Thread BSPT	C Hex. (mm)	L (mm)	N (mm)
T23FPK4-1/8	4	1/8	12	36	19.5
T23FPK4-1/4	4	1/4	14	40	19.5
T23FPK6-1/8	6	1/8	14	40	21.0
T23FPK6-1/4	6	1/4	14	40	21.0
T23FPK8-1/8	8	1/8	17	45	22.0
T23FPK8-1/4	8	1/4	17	46	22.0
T23FPK8-3/8	8	3/8	17	44	22.0
T23FPK10-1/4	10	1/4	19	57	27.0
T23FPK10-3/8	10	3/8	19	55	27.0
T23FPK10-1/2	10	1/2	22	52	27.0

T24FPK Tube End Male Adaptor BSPP

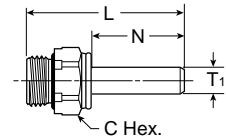

Part No.	Tube Size (mm)	Thread BSPP	C Hex. (mm)	J (mm)	L (mm)	N (mm)
T24FPK4-1/8	4	1/8	14	6	38	19.0
T24FPK4-1/4	4	1/4	16	9	38	19.5
T24FPK6-1/8	6	1/8	14	6	41	21.0
T24FPK6-1/4	6	1/4	16	9	41	20.5
T24FPK8-1/8	8	1/8	14	6	45	22.0
T24FPK8-1/4	8	1/4	16	9	45	22.0
T24FPK8-3/8	8	3/8	19	9	45	22.0
T24FPK10-1/4	10	1/4	19	9	57	27.0
T24FPK10-3/8	10	3/8	19	9	51	26.0
T24FPK10-1/2	10	1/2	27	12	50	27.0

Protective Cap



Part No.	
	1
C4*	4
C6*	6
C8*	8
C10*	10
C12*	12
C14*	14

J3PK Manifold for 3 Tubes

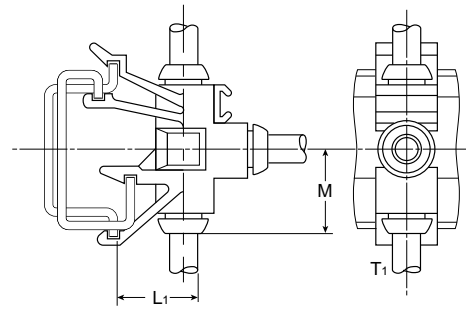

Part No.	Tube Size (mm)	L1 (mm)	M (mm)
J3PK4	4	14	16
J3PK6	6	15	18
J3PK8	8	15	29

*Add the following code, corresponding to the chosen color W: white; BU: blue; G: green; R: red; Y: yellow; BL: black. Example: cap red suitable for tube 4mm: C4R. In case of no color specification, we will deliver yellow cap (standard color).

HS3PK Manifold for 2 Tubes and Pressure Indicator

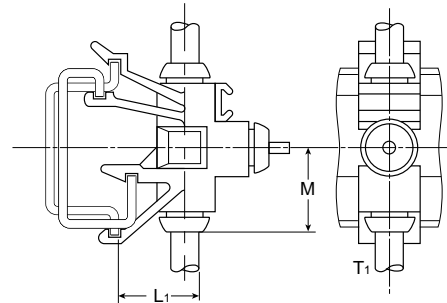

Part No.	Tube Size (mm)	L1 (mm)	M (mm)
HS3PK4	4	14	16
HS3PK6	6	15	18
HS3PK8	8	15	29

TS2PK Pressure Indicator

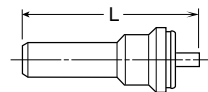

Part No.	Tube Size (mm)	L (mm)
TS2PK4	4	36
TS2PK6	6	37
TS2PK8	8	36

F



20 Plug

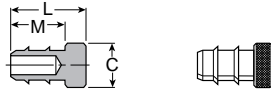

Part No.	Tube O.D.	Tube I.D.	C Dia.	L	M
20-4	1/4	0.170	0.290	0.56	0.41
20-6	3/8	0.250	0.390	0.68	0.44
20-8	1/2	0.377	0.577	0.81	0.56

20 Plug Adapter

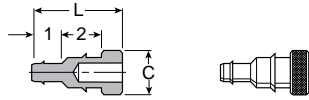

Part No.	Tube 1 O.D.	Tube 1 I.D.	Tube 2 O.D.	Tube 2 I.D.	C Dia.	L
20-4-5/32	5/32	0.096	1/4	0.170	0.290	0.65

22 Union

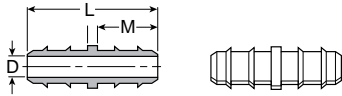

Part No.	Tube O.D.	Tube I.D.	L	M	Flow Dia. D
22-5/32	5/32x5/32	0.096x0.096	0.59	0.28	0.062
22-4	1/4x1/4	0.170x0.170	0.84	0.41	0.120
22-6	3/8x3/8	0.250x0.250	0.94	0.44	0.187
22-8	1/2x1/2	0.375x0.375	1.19	0.56	0.312

22 Union Reducer

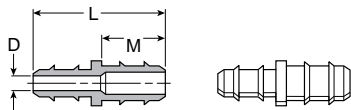

Part No.	Tube O.D.	Tube I.D.	L	M	Flow Dia. D
22-4-5/32	1/4x5/32	0.170x0.096	0.72	0.41	0.062
22-4-6	1/4x3/8	0.170x0.250	0.88	0.44	0.120
22-4-8	1/4x1/2	0.170x0.375	1.06	0.56	0.120
22-6-8	3/8x1/2	0.250x0.375	1.06	0.56	0.187

22BH Bulkhead Union

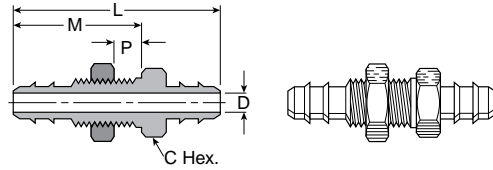

Part No.	Tube O.D.	Tube I.D.	Straight Thread	C Hex.	P Max.	L	M	Flow Dia. D	Bkd. Dia.
22BH-4-4	1/4	0.170	5/16-24	7/16	0.219	1.38	0.78	0.120	5/16
22BH-6-6	3/8	0.250	3/8-24	9/16	0.375	1.63	1.00	0.187	3/8

22CA Union

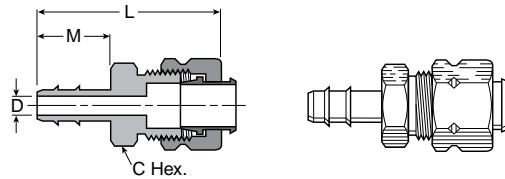

Part No.	Tube O.D.	Tube I.D.	CA Tube	C Hex.	L	M	Flow Dia. D
22CA-4-4	1/4	0.170	1/4	7/16	1.15	0.41	0.120

22CABH Union

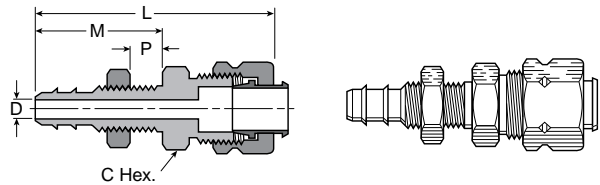

Part No.	Tube O.D.	Tube I.D.	CA Tube	Std. Thd.	C Hex.	P Max.	L	M	Flow Dia. D	Bkd. Hole Dia.
22CABH-4-4	1/4	0.170	1/4	5/16-24	7/16	0.219	1.53	0.78	0.120	5/16
22CABH-6-6	3/8	0.250	3/8	3/8-24	9/16	0.375	1.87	1.00	0.187	3/8

26 Female Connector

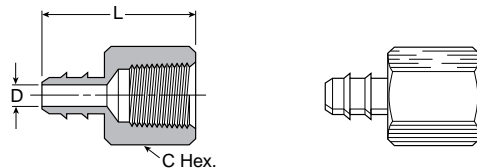

Part No.	Tube O.D.	Tube I.D.	Pipe Thread	C Hex.	L	Flow Dia. D
26-5/32-2	5/32	0.096	1/8	1/2	0.79	0.062
26-4-2	1/4	0.170	1/8	1/2	0.91	0.120
26-6-2	3/8	0.250	1/8	1/2	0.93	0.187
26-6-4	3/8	0.250	1/4	11/16	1.06	0.187

F



27 Male Connector



Part No.	Tube O.D.	Tube I.D.	Pipe Thread	C Hex.	L	Flow Dia. D
27-1*	1/8	0.062	10-32 UNF	1/4	0.61	0.052
27-2*	1/4	0.125	10-32 UNF	1/4	0.74	0.093

*For vinyl tubing only.

28 Barb to Pipe Adapter

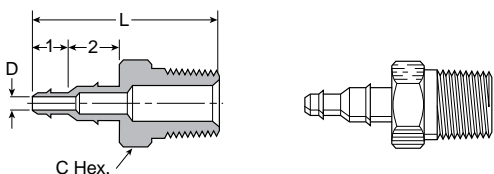

Part No.	Tube O.D. 1	Tube I.D. 1	Tube O.D. 2	Tube I.D. 2	Pipe Thread	C Hex.	F	Flow Dia. D
28-4-5/32-2	5/32	0.096	1/4	0.170	1/8	7/16	1.07	0.062

28 Male Connector

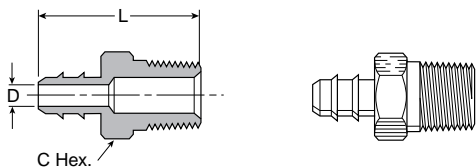

Part No.	Tube O.D.	Tube I.D.	Pipe Thread	C Hex.	L	Flow Dia. D
28-5/32-2	5/32	0.096	1/8	7/16	0.84	0.062
28-4-1	1/4	0.170	1/16	11/32	0.93	0.120
28-4-2	1/4	0.170	1/8	7/16	0.97	0.120
28-4-4	1/4	0.170	1/4	9/16	1.09	0.120
28-4-10x32*	1/4	.170	10-32	1/4	0.71	0.093
28-6-2	3/8	0.250	1/8	7/16	1.00	0.187
28-6-4	3/8	0.250	1/4	9/16	1.13	0.187
28-8-4	1/2	0.375	1/4	9/16	1.25	0.312
28-8-6	1/2	0.375	3/8	11/16	1.28	0.312
28-8-8	1/2	0.375	1/2	7/8	1.44	0.312

* Straight Thread

220 Adapter Tee

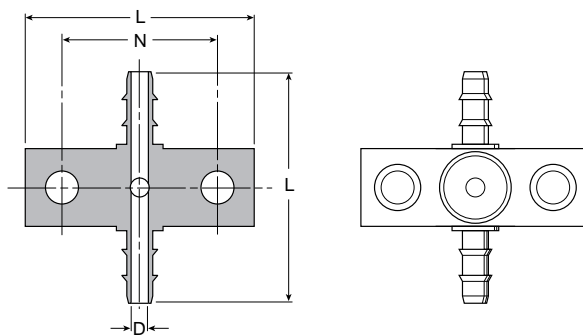

Part No.	Tube O.D.	Tube I.D.	Pipe Thread	L	M	Flow Dia. D
220-4-2	1/4	0.170	1/8	1.50	1.00	0.120

224 Union Tee

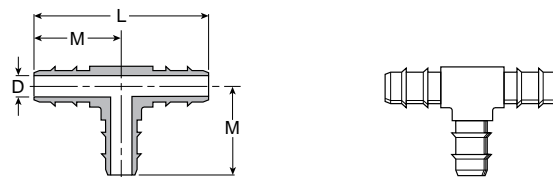

Part No.	Tube O.D.	Tube I.D.	L	M	Flow Dia. D
224-5/32	5/32	0.096	1.00	0.50	0.062
224-4	1/4	0.170	1.25	0.63	0.120
224-6	3/8	0.250	1.38	0.69	0.187
224-8	1/2	0.375	1.63	0.81	0.312

224 Union Tee (Combination Sizes)

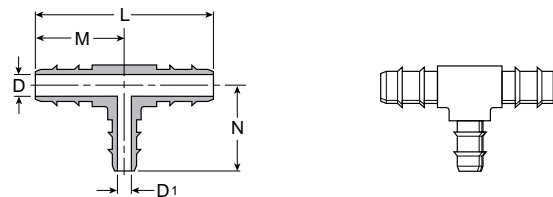

Part No.	Tube O.D.	Tube I.D.	L	M	N	Flow Dia. D	Flow Dia. D ₁
224-4-4-5/32	1/4x5/32	0.170x0.096	1.25	0.63	0.50	0.120	0.062
224-6-6-5/32	3/8x5/32	0.250x0.096	1.38	0.69	0.50	0.187	0.062
224-6-6-4	3/8x1/4	0.250x0.170	1.38	0.69	0.62	0.187	0.120
224-8-8-4	1/2x1/4	0.375x0.170	1.62	0.81	0.65	0.312	0.120
224-8-8-6	1/2x3/8	0.375x0.250	1.62	0.81	0.69	0.312	0.187



225 Union Elbow



Part No.	Tube O.D.	Tube I.D.	L	M	Flow Dia. D
225-5/32	5/32	0.096	0.50	0.50	0.062
225-4-4	1/4	0.170	0.63	0.63	0.120
225-6-6	3/8	0.250	0.69	0.69	0.187
225-8-8	1/2	0.375	0.81	0.81	0.312

225 Union Elbow Combination Size

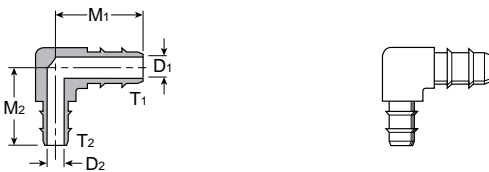

Part No.	Tube 1 O.D.	Tube 1 I.D.	Tube 2 O.D.	Tube 2 I.D.	M1	M2	Flow Dia. D1	Flow Dia. D2
225-4-5/32	1/4	0.170	5/32	0.096	0.63	0.50	0.120	0.062

228 Gauge Tee

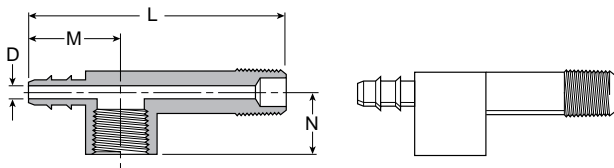

Part No.	Tube O.D.	Tube I.D.	Pipe Thread	L	M	N	Flow Dia. D
228-4-2	1/4	0.170	1/8	1.91	0.66	0.44	0.120

229 Male Elbow

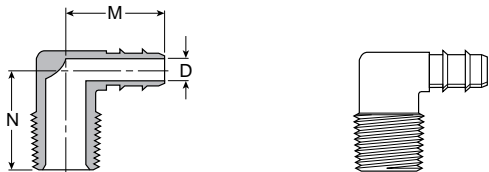

Part No.	Tube O.D.	Tube I.D.	Pipe Thread	M	N	Flow Dia. D
229-5/32-2	5/32	0.096	1/8	0.56	0.63	0.062
229-4-1	1/4	0.170	1/16	0.62	0.60	0.120
229-4-2	1/4	0.170	1/8	0.69	0.63	0.120
229-4-4	1/4	0.170	1/4	0.72	0.72	0.120
229-6-2	3/8	0.250	1/8	0.69	0.69	0.187
229-6-4	3/8	0.250	1/4	0.75	0.75	0.187
229-8-4	1/2	0.375	1/4	0.94	0.74	0.312
229-8-6	1/2	0.375	3/8	0.94	0.81	0.312

229 Barb Adapter Elbow 90°

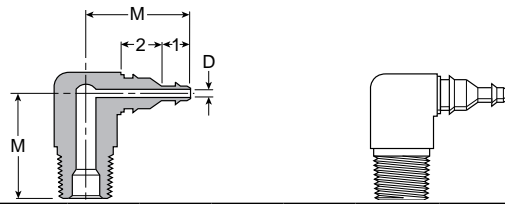

Part No.	Tube O.D. 1	Tube I.D. 1	Tube O.D. 2	Tube I.D. 2	Pipe Thread	M	Flow Dia. D
229-4-5/32-2	5/32	0.096	1/4	0.170	1/8	0.78	0.062

230 Female Elbow

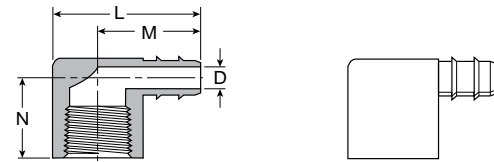

Part No.	Tube O.D.	Tube I.D.	Pipe Thread	L	M	N	Flow Dia. D
230-4-2	1/4	0.170	1/8	0.91	0.66	0.44	0.120
230-6-4	3/8	0.250	1/4	1.12	0.78	0.63	0.187

231 Male Run Tee

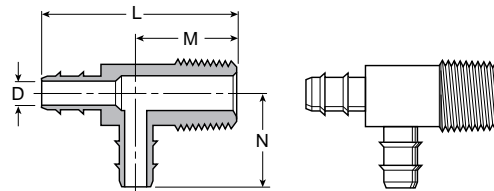

Part No.	Tube O.D.	Tube I.D.	Pipe Thread	L	M	N	Flow Dia. D
231-4-2	1/4	0.170	1/8	1.28	0.66	0.69	0.120
231-6-2	3/8	0.250	1/8	1.38	0.69	0.69	0.187
231-6-4	3/8	0.250	1/4	1.44	0.75	0.75	0.187

232 Male Branch Tee

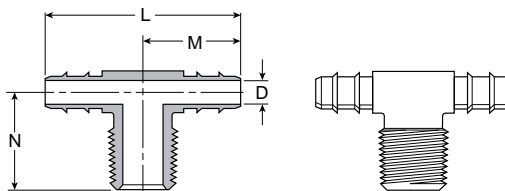

Part No.	Tube O.D.	Tube I.D.	Pipe Thread	L	M	N	Flow Dia. D
232-4-1	1/4	0.170	1/16	1.33	0.66	0.65	0.120
232-4-2	1/4	0.170	1/8	1.38	0.69	0.66	0.120
232-6-2	3/8	0.250	1/8	1.38	0.69	0.69	0.187
232-6-4	3/8	0.250	1/4	1.50	0.75	0.75	0.187

F



233 Tee

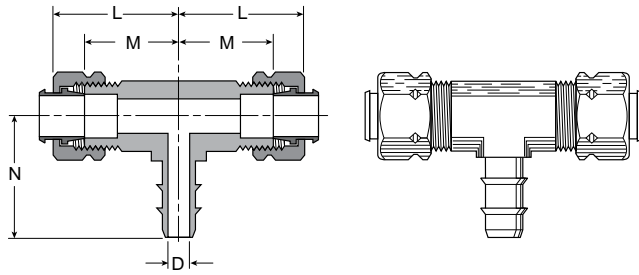

Part No.	Tube O.D.	Tube I.D.	Comp. Tube	L	M	N	Flow Dia. D
233-4-4-4	1/4	0.170	1/4	0.73	0.53	0.74	0.120
233-6-6-4	1/4	0.170	3/8	0.87	0.59	0.80	0.120

238 Solder Connector



Part No.	Tube O.D. 1	Tube I.D. 2	L	M	Flow Dia. D
238-4-4	1/4	0.170	0.91	0.254	0.120

237 Female Branch Tee

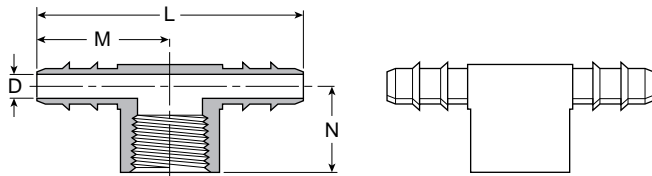

Part No.	Tube O.D.	Tube I.D.	Pipe Thread	L	M	N	Flow Dia. D
237-5/32-2	5-32	0.096	1/8	1.06	0.53	0.44	0.062
237-4-2	1/4	0.170	1/8	1.34	0.67	0.49	0.120



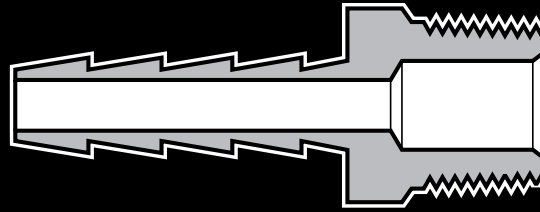

Hose Barb Fittings

Advantages

All Parker hose barb fitting pipe threads are made to Dryseal standards. Connectors, unions, nuts and extruded elbows and tees are machined from CA 360 and CA 345 brass rod.

Working Pressure and Temperature Ranges

From -40°F to 160°F at 150 PSI maximum.

Note:
 These fittings are intended for use with 97HC hose clamp, similar type clamp or a crimped ferrule.

Assembly Instructions

1. Cut hose cleanly and squarely to length.
2. Slide clamp on hose.
3. Lubricate hose. Push hose on fitting until hose bottoms against stop ring or hex.
4. Position hose clamp as shown below and secure with a screwdriver or wrench. Maintain "A" dimension noted below for proper clamp positioning.

Nomenclature

Part numbers are constructed from symbols that identify the style and size of the fitting. The first series of numbers and letters identifies the style and type fitting. The second series of numbers describes the size.

Example: **125 HBL -6 -4**

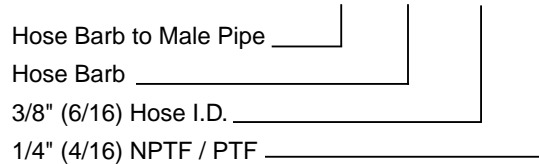

Sizes

Pipe sizes are determined by the number of sixteenths of an inch in the pipe size.

Special Fittings

Fitting configurations and/or sizes other than those shown in the catalog can be furnished. It is suggested that a print or sketch be submitted with the inquiry.

F

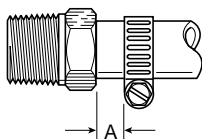

Hose Size	Hose Clamp	A
3/16"	97 HC-3	1/4"
1/4"	97 HC-3	1/4"
5/16"	97 HC-6	1/4"
3/8"	97 HC-6	1/8"
1/2"	97 HC-8	1/8"
5/8"	97 HC-12	1/8"
3/4"	97 HC-12	1/8"

68HB Beaded Hose Barb to Male Pipe

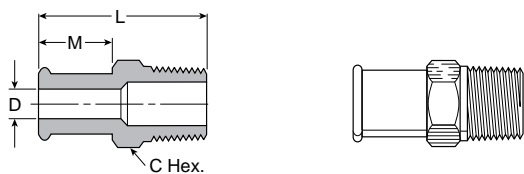

Part No.	I.D. Hose Size	Pipe Thread	C Hex.	L	M	Flow Dia. D
68HB-6-6	3/8	3/8	11/16	1.53	0.78	0.281
68HB-8-4	1/2	1/4	5/8	1.56	0.78	0.375
68HB-8-6	1/2	3/8	11/16	1.53	0.78	0.406
68HB-8-8	1/2	1/2	7/8	1.73	0.78	0.406
68HB-10-6	5/8	3/8	3/4	1.62	0.88	0.501
68HB-10-8	5/8	1/2	7/8	1.92	0.88	0.501
68HB-12-8	3/4	1/2	7/8	1.98	0.88	0.564
68HB-12-12	3/4	3/4	1-1/16	2.04	0.97	0.625
68HB-16-12	1	3/4	1-1/8	2.12	1.00	0.750
68HB-16-16	1	1	1-3/8	2.31	1.00	0.812

685HB Beaded Hose Barb to SAE Straight Thread

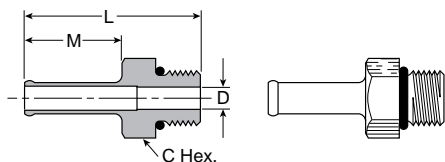

Part No.	I.D. Hose Size	Straight Thread	C Hex.	L	M	Flow Dia. D
685HB-6-6	1/4	7/16-20	9/16	1.40	0.78	0.18
685HB-6-4	3/8	7/16-20	9/16	1.39	0.78	0.18
685HB-8-8	1/2	3/4-16	7/8	1.48	0.78	0.40
685HB-10-8	5/8	3/4-16	7/8	1.56	0.78	0.40
685HB-12-8	3/4	3/4-16	7/8	1.75	0.97	0.40
685HB-12-12	3/4	1-1/16-12	1-1/4	1.82	0.97	0.62
685HB-16-8	1	3/4-16	1-1/8	1.79	0.97	0.40
685HB-16-12	1	1-1/16-12	1-1/4	1.99	0.97	0.62

Note: Fluorocarbon O-ring is Standard.

97HC Steel Worm Drive Clamp

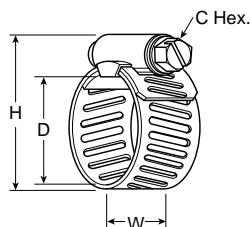

Part No.	D		C Hex.	H Max.	W
	Max.	Min.			
97HC-3	0.62	0.25	0.25	1.00	0.31
97HC-6	0.87	0.38	0.31	1.40	0.50
97HC-8	1.00	0.44	0.31	1.53	0.50
97HC-12	1.25	0.50	0.31	1.80	0.50

122HBL Hose Mender

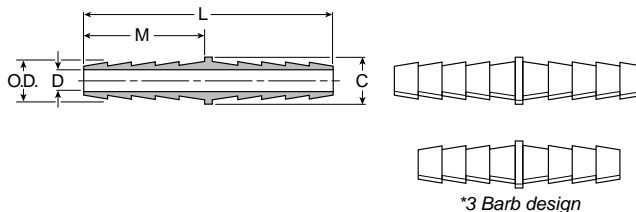

Part No.	I.D. Hose Size	C Dia.	L	M	O.D.	Flow Dia. D
122HB-3*	3/16	5/16	1.44	0.69	0.227	0.125
122HBL-4	1/4	3/8	2.00	0.97	0.290	0.187
122HBL-5	5/16	7/16	2.00	0.97	0.353	0.250
122HBL-6	3/8	1/2	2.00	0.97	0.415	0.281
122HBL-8	1/2	5/8	2.00	0.97	0.530	0.375
122HBL-12	3/4	7/8	2.00	0.97	0.7.90	0.562

*3 Barb design.

125HB Hose Barb to Male Pipe

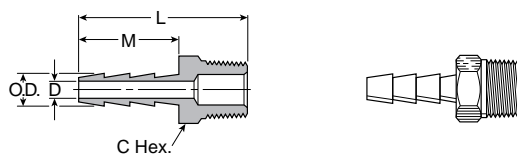

Part No.	I.D. Hose Size	Pipe Thread	C Hex.	L	M	O.D.	Flow Dia. D
125HB-2-2	1/8	1/8	7/16	1.07	.50	.185	.093
125HB-3-2	3/16	1/8	7/16	1.25	.69	.227	.125
125HB-3-4	3/16	1/4	9/16	1.44	.69	.227	.125



125HBL Hose Barb to Male Pipe

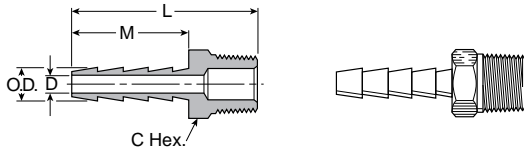

Part No.	I.D. Hose Size	Pipe Thread	C Hex.	L	M	O.D.	Flow Dia. D
125HBL-4-2	1/4	1/8	7/16	1.54	0.97	0.290	0.187
125HBL-4-4	1/4	1/4	9/16	1.72	0.97	0.290	0.187
125HBL-4-6	1/4	3/8	11/16	1.77	0.97	0.290	0.187
125HBL-5-2	5/16	1/8	7/16	1.54	0.97	0.353	0.250
125HBL-5-4	5/16	1/4	9/16	1.72	0.97	0.353	0.250
125HBL-5-6	5/16	3/8	11/16	1.77	0.97	0.353	0.250
125HBL-6-2	3/8	1/8	7/16	1.54	0.97	0.415	0.281
125HBL-6-4	3/8	1/4	9/16	1.72	0.97	0.415	0.281
125HBL-6-6	3/8	3/8	11/16	1.77	0.97	0.415	0.281
125HBL-6-8	3/8	1/2	7/8	1.97	0.97	0.415	0.281
125HBL-8-4	1/2	1/4	9/16	1.72	0.97	0.530	0.375
125HBL-8-6	1/2	3/8	11/16	1.77	0.97	0.530	0.375
125HBL-8-8	1/2	1/2	7/8	1.97	0.97	0.530	0.375
125HBL-8-12	1/2	3/4	1-1/16	1.98	0.97	0.530	0.375
125HBL-10-6	5/8	3/8	11/16	1.77	0.97	0.645	0.468
125HBL-10-8	5/8	1/2	7/8	1.97	0.97	0.645	0.468
125HBL-10-12	5/8	3/4	1-1/16	1.98	0.97	0.645	0.468
125HBL-12-8	3/4	1/2	7/8	1.97	0.97	0.790	0.562
125HBL-12-12	3/4	3/4	1-1/16	1.98	0.97	0.790	0.562
125HBL-16-12	1	3/4	1-1/16	2.18	1.17	1.020	0.750
125HBL-16-16	1	1	1-3/8	2.36	1.17	1.020	0.875

125HBLSV Male Swivel Hose Barb

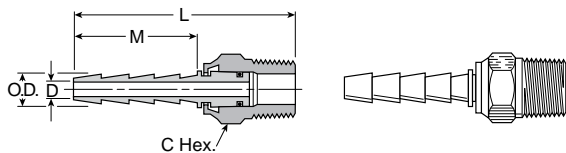

Part No.	I.D. Hose Size	Pipe Thread	C Hex.	L	M	O.D.	Flow Dia. D
125HBLSV-4-4	1/4	1/4	11/16	2.14	0.97	0.290	0.187
125HBLSV-6-4	3/8	1/4	11/16	2.14	0.97	0.415	0.250
125HBLSV-6-6	3/8	3/8	11/16	2.14	0.97	0.415	0.250
125HBLSV-8-8	1/2	1/2	7/8	2.48	0.97	0.530	0.375

126HBL Hose Barb to Female Pipe

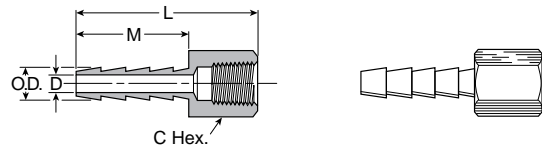

Part No.	I.D. Hose Size	Pipe Thread	C Hex.	L	M	O.D.	Flow Dia. D
126HBL-4-2	1/4	1/8	1/2	1.47	0.97	0.290	0.187
126HBL-4-4	1/4	1/4	11/16	1.58	0.97	0.290	0.187
126HBL-5-4	5/16	1/4	11/16	1.58	0.97	0.353	0.250
126HBL-6-2	3/8	1/8	1/2	1.47	0.97	0.415	0.281
126HBL-6-4	3/8	1/4	11/16	1.58	0.97	0.415	0.281
126HBL-6-6	3/8	3/8	13/16	1.63	0.97	0.415	0.281
126HBL-8-6	1/2	3/8	13/16	1.59	0.97	0.530	0.375
126HBL-8-8	1/2	1/2	1	1.73	0.97	0.530	0.375
126HBL-12-8	3/4	3/4	1-1/4	1.92	0.97	0.790	0.562

127HB Ball End Joint Adapter to Male Pipe

(For use with 128HBLSV)



Part No.	Pipe Thread (NPSM)	Pipe Thread	C Hex.	L	Flow Dia. D
127HB-4-2	1/4	1/8	9/16	0.91	0.219
127HB-4-4	1/4	1/4	9/16	1.10	0.281
127HB-6-4	3/8	1/4	11/16	1.10	0.312
127HB-6-6	3/8	3/8	11/16	1.15	0.406
127HB-8-6	1/2	3/8	7/8	1.25	0.406
127HB-8-8	1/2	1/2	7/8	1.50	0.531

128HBLSV Hose Barb to Swivel Female Ball End (Must be used with 127HP Adapter)

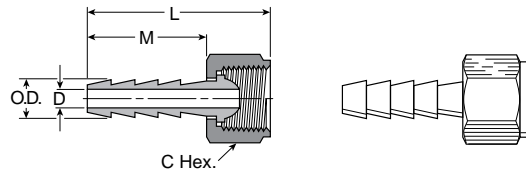

Part No.	I.D. Hose Size	Pipe Thread (NPSM)	C Hex.	L	M	O.D.	Flow Dia. D
128HBLSV-4-4	1/4	1/4	5/8	1.50	0.97	0.290	0.187
128HBLSV-5-4	5/16	1/4	5/8	1.50	0.97	0.353	0.250
128HBLSV-6-4	3/8	1/4	5/8	1.63	0.97	0.415	0.250
128HBLSV-6-6	3/8	3/8	3/4	1.50	0.97	0.415	0.281
128HBLSV-8-8	1/2	1/2	29/32	1.52	0.97	0.530	0.375

F



129HB Hose Barb 90° Elbow to Male Pipe

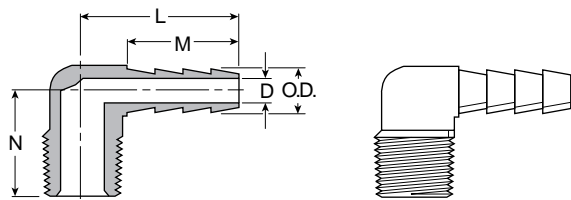

Part No.	I.D. Hose Size	Pipe Thread	L	M	N	O.D.	Flow Dia. D
129HB-3-2	3/16	1/8	0.97	0.69	0.66	0.227	0.173
129HB-4-2	1/4	1/8	1.04	0.76	0.66	0.290	0.187
129HB-4-4	1/4	1/4	1.06	0.76	0.86	0.290	0.187
129HB-4-6	1/4	3/8	1.30	0.76	0.84	0.290	0.187
129HB-5-2	5/16	1/8	1.06	0.76	0.66	0.353	0.234
129HB-5-4	5/16	1/4	1.12	0.76	0.84	0.353	0.234
129HB-5-6	5/16	3/8	1.19	0.76	0.84	0.353	0.234
129HB-6-2	3/8	1/8	1.32	0.97	0.94	0.415	0.281
129HB-6-4	3/8	1/4	1.32	0.97	0.94	0.415	0.281
129HB-6-6	3/8	3/8	1.50	0.97	1.06	0.415	0.281
129HB-6-8	3/8	1/2	1.52	0.97	1.25	0.415	0.281
129HB-8-4	1/2	1/4	1.53	0.97	1.06	0.530	0.375
129HB-8-6	1/2	3/8	1.53	0.97	1.06	0.530	0.375
129HB-8-8	1/2	1/2	1.53	0.97	1.25	0.530	0.375
129HB-12-12	3/4	3/4	1.33	0.79	1.27	0.790	0.562

1295HB Hose Barb Elbow to SAE Straight Thread

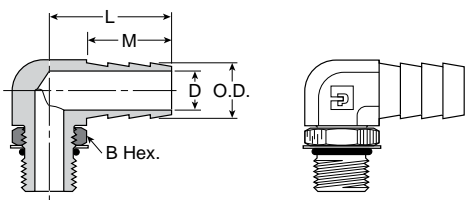

Part No.	I.D. Hose Size	Straight Thread	B Hex.	L	M	O.D.	Flow Dia. D
1295HB-6-6	3/84	9/16-18	11-16	1.10	1.11	0.410	0.270

Note: Fluorocarbon o-ring is standard

139HB Hose Barb 45° Elbow to Male Pipe

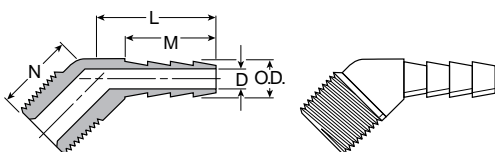

Part No.	I.D. Hose Size	Pipe Thread	L	M	N	O.D.	Flow Dia. D
139HB-4-2	1/4	1/8	0.91	0.76	0.68	0.290	0.187
139HB-4-4	1/4	1/4	1.00	0.76	0.68	0.290	0.187
139HB-6-4	3/8	1/4	1.00	0.76	0.68	0.415	0.281

1695HB Beaded Hose Barb Elbow to SAE Straight Thread

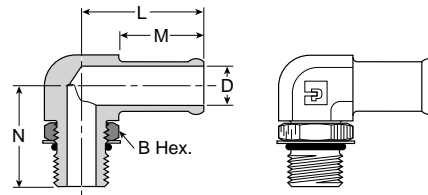

Part Number	Hose Size	Straight Thread	B Hex.	L	M	N	Flow Dia. D
1695HB-6-4	3/8	7/16-20	9/16	1.09	0.78	1.10	0.18
1695HB-8-6	1/2	9/16-18	9/16	1.10	0.78	1.11	0.30
1695HB-8-8	1/2	3/4-16	7/8	1.28	0.78	1.47	0.40
1695HB-10-8	5/8	3/4-16	7/8	1.47	0.88	1.47	0.40
1695HB-10-10	5/8	7/8-14	1	1.41	0.88	1.60	0.50
1695HB-12-8	3/4	3/4-16	7/8	1.47	0.97	1.47	0.40
1695HB-12-10	3/4	7/8-14	1	1.60	0.97	1.62	0.50
1695HB-12-12	3/4	1 1/16-12	1	1.60	0.97	1.64	0.62
1695HB-16-12	1	1 1/16-12	1 1/4	1.60	0.97	1.75	0.60

Note: Fluorocarbon o-ring is standard

171HB Hose Barb Tee to Male Pipe

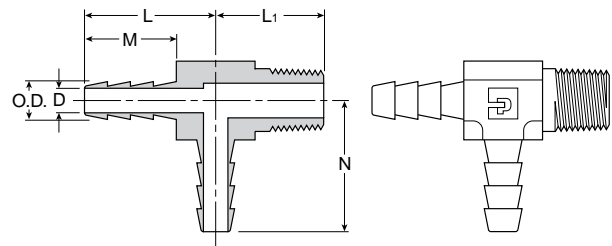

Part No.	I.D. Hose Size	Pipe Thread	L	L1	M	N	O.D.	Flow Dia. D
171HB-4-4	1/4	1/4	1.10	0.85	0.76	1.10	0.290	0.187

179HB Beaded Hose Barb Elbow to SAE Straight Thread 1695HB

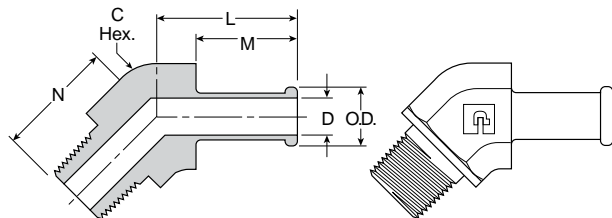

Part No.	I.D. Hose Size	Pipe Thread	C Hex.	L	M	N	O.D.	Flow Dia. D
179HB-6-4	3/8	1/4-18	0.75	1.09	0.78	0.93	0.45	0.28
179HB-6-6	3/8	3/8-18	0.75	1.09	0.78	0.93	0.45	0.28
179HB-10-8	5/8	1/2-14	0.81	1.19	0.78	1.13	0.70	0.50
179HB-12-8	3/4	1/2-14	0.81	1.19	0.78	1.13	0.83	0.56



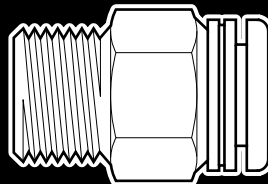

Global Connect Fittings

Advantages

Ready-to-use compact one piece fitting for use with most thermoplastic tubing. This fitting was designed to meet the needs of the motion control industry where fast assembly, disassembly and reassembly is important. No special tools needed for tube assembly, just insert the tubing until it bottoms. Global Connect is designed to be used without a tube support to provide full flow through the tubing. The grab ring design of Global Connect grips the tubing securely to provide retention. Global Connect straight fittings have a nickel plated brass body and shaped fittings have a composite body with nickel plated brass components. Global Connect external pipe threads come with a pre-applied white PCTFE sealant. Positional external pipe threaded ends are featured on shapes for installation in compact areas and for precise positioning. *Global Connect fittings should not be used for live swivel applications.*

Materials

- Global Connect Straights: Brass, Nickel Plated
- Global Connect Shape Bodies: Polyamide
- Ellipse Button: Acetal Copolymer
- Grab Ring Stainless Steel
- O-Ring: Nitrile
- Sealant: PCTFE

Applications

Use with Parker Parflex series "U" and "HU" polyurethane tubing and series "N" nylon tubing. Global Connect was designed as an economical alternative for pneumatic applications that do not require the higher pressure capacity of the Prestolok fittings.

Consult the factory with any questions regarding special product applications. All applications should be carefully tested through the range of conditions which may be encountered prior to use.

Working Pressure and Temperature Range

32° to 140°F at up to 150 PSI depending on tubing being used.

Vacuum applications are dependent upon temperature and type of tubing used.

Assembly Instructions

1. Cut thermoplastic tubing squarely, using Parker Tube Cutter PTC-001. Be certain the port or mating part is clean and free of debris.
2. Insert tubing into fitting until it bottoms. A slight twisting motion will ease the insertion. Pull on tubing to verify it is properly retained in the fitting.
3. To disassemble, simply push the elliptical button against the body and remove tubing.

Nomenclature

Part numbers are constructed from symbols that identify the style and size of the fitting. The first series of numbers and letters identify the style and type fitting. The second series of numbers describe the size.

Note: 0 indicates 10-32 UNF Thread

Example: **W 369 GC -4 -2**

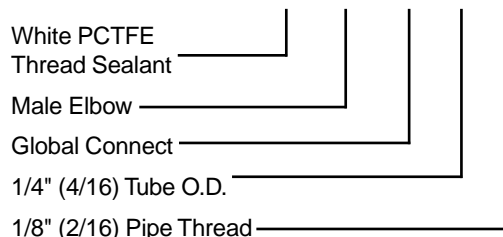

Sizes

Tube sizes are determined by the number of sixteenths of an inch in the tube O.D.

F

32GC Union

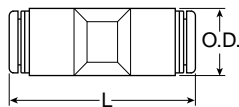

Part No.	Tube Size	O.D.	L
32GC-2	1/8	0.433	1.299
32GC-5/32	5/32	0.433	1.300
32GC-3	3/16	0.512	1.535
32GC-4	1/4	0.560	1.570
32GC-5	5/16	0.610	1.614
32GC-6	3/8	0.728	1.890
32GC-8	1/2	0.866	2.362

HGC Union (Metric)

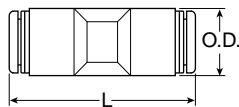

Part No.	Tube Size (mm)	O.D. (mm)	L (mm)
HGC4	4	11.00	33.00
HGC6	6	13.00	39.00
HGC8	8	15.50	41.00
HGC10	10	18.50	48.00
HGC12	12	22.00	60.00

66GC Female Connector

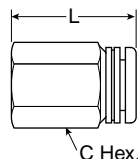

Part No.	Tube Size	Pipe Thread	C Hex.	L
66GC-3-2	3/16	1/8	1/2	1.12
66GC-4-2	1/4	1/8	1/2	1.11
66GC-4-4	1/4	1/4	5/8	1.31
66GC-5/32-2	5/32	1/8	1/2	1.07
66GC-5/32-4	5/32	1/4	5/8	1.26
66GC-5-2	5/16	1/8	9/16	1.17
66GC-5-4	5/16	1/4	5/8	1.33
66GC-6-4	3/8	1/4	13/16	1.40
66GC-6-6	3/8	3/8	13/16	1.45

68GC Male Connector

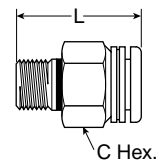

Part No.	Tube Size	Pipe Thread	C Hex.	L
68GC-2-0	1/8	10-32	1/2	0.925
68GC-5/32-0	5/32	10-32	1/2	0.913
68GC-3-0	3/16	10-32	9/16	0.898
68GC-4-0	1/4	10-32	9/16	0.898

W68GC Male Connector

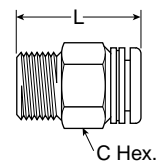

Part No.	Tube Size	Pipe Thread	C Hex.	L
W68GC-2-1	1/8	1/16	1/2	0.945
W68GC-2-2	1/8	1/8	1/2	0.945
W68GC-2-4	1/8	1/4	9/16	1.150
W68GC-5/32-1	5/32	1/16	1/2	0.937
W68GC-5/32-2	5/32	1/8	1/2	0.937
W68GC-5/32-4	5/32	1/4	9/16	1.142
W68GC-3-2	3/16	1/8	9/16	0.980
W68GC-3-4	3/16	1/4	9/16	1.181
W68GC-4-1	1/4	1/16	9/16	1.134
W68GC-4-2	1/4	1/8	9/16	0.980
W68GC-4-4	1/4	1/4	9/16	1.181
W68GC-4-6	1/4	3/8	13/16	1.185
W68GC-5-2	5/16	1/8	5/8	1.340
W68GC-5-4	5/16	1/4	5/8	1.357
W68GC-5-6	5/16	3/8	13/16	1.347
W68GC-6-2	3/8	1/8	13/16	1.319
W68GC-6-4	3/8	1/4	13/16	1.437
W68GC-6-6	3/8	3/8	13/16	1.437
W68GC-6-8	3/8	1/2	15/16	1.630
W68GC-8-4	1/2	1/4	15/16	1.555
W68GC-8-6	1/2	3/8	15/16	1.547
W68GC-8-8	1/2	1/2	15/16	1.724

All dimensions are preliminary and could change during final production.



F3GC Male Connector BSPT (Metric)

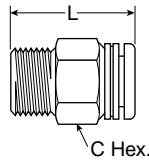

Part No.	Tube Size (mm)	BSPT Thread	C Hex. (mm)	L (mm)
F3GC4-1/8	4	1/8	12	21.0
F3GC4-1/4	4	1/4	14	18.5
F3GC6-1/8	6	1/8	14	22.0
F3GC6-1/4	6	1/4	14	22.8
F3GC8-1/8	8	1/8	17	26.0
F3GC8-1/4	8	1/4	17	23.5
F3GC8-3/8	8	3/8	17	22.6
F3GC10-1/4	10	1/4	21	31.5
F3GC10-3/8	10	3/8	21	29.0
F3GC10-1/2	10	1/2	22	28.0
F3GC12-1/4	12	1/4	22	33.8
F3GC12-3/8	12	3/8	22	31.8
F3GC12-1/2	12	1/2	22	33.8

F8GC Male Connector for Metric Thread

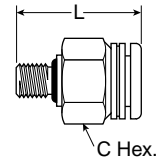

Part No.	Tube Size (mm)	Metric Thread	C Hex. (mm)	L (mm)
F8GC4M5	4	M5	12	22.0
F8GC6M5	6	M5	14	27.5
F8GC6M10	6	M10	14	25.0
F8GC6M12	6	M12	17	26.5
F8GC8M12	8	M12	17	28.3
F8GC8M16	8	M16	21	29.8

F4GC Male Connector BSPP (Metric)

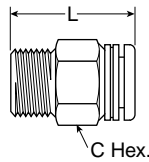

Part No.	Tube Size (mm)	BSPP Thread	C Hex. (mm)	L (mm)
F4GC4-1/8	4	1/8	12	22.0
F4GC4-1/4	4	1/4	14	20.0
F4GC6-1/8	6	1/8	14	27.5
F4GC6-1/4	6	1/4	14	27.0
F4GC8-1/8	8	1/8	17	28.8
F4GC8-1/4	8	1/4	17	28.8
F4GC8-3/8	8	3/8	21	28.8
F4GC10-1/4	10	1/4	21	37.0
F4GC10-3/8	10	3/8	21	34.0
F4GC10-1/2	10	1/2	24	36.0
F4GC12-1/4	12	1/4	22	37.7
F4GC12-3/8	12	3/8	22	33.7
F4GC12-1/2	12	1/2	24	35.7

364GC Union Tee

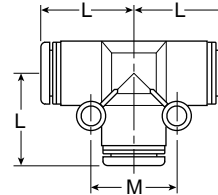

Part No.	Tube Size	Mounting Hole Dia.	L	M
364GC-2	1/8	*	0.689	*
364GC-5/32	5/32	*	0.689	*
364GC-3	3/16	0.138	0.748	0.63
364GC-4	1/4	0.150	0.820	0.72
364GC-5	5/16	0.173	0.906	0.81
364GC-6	3/8	0.165	1.110	0.92
364GC-8	1/2	0.165	1.134	1.04

JGC Union Tee (Metric)

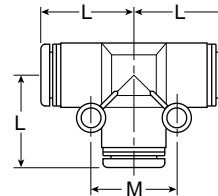

Part No.	Tube Size (mm)	Mounting Hole Dia. (mm)	L (mm)	M (mm)
JGC4	4	*	17.50	*
JGC6	6	18.80	16.00	3.50
JGC8	8	23.00	20.60	4.40
JGC10	10	28.50	23.40	4.20
JGC12	12	29.00	26.30	4.20

All dimensions are preliminary and could change during final production. *Note 1/8", 5/32" and 4mm sizes do not have mounting holes.

F



365GC Union Elbow

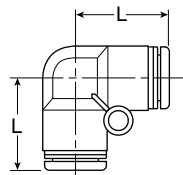

Part No.	Tube Size	Mounting Hole Dia.	L
365GC-2	1/8	*	0.65
365GC-5/32	5/32	*	0.65
365GC-3	3/16	0.130	0.76
365GC-4	1/4	0.130	0.76
365GC-5	5/16	0.170	0.87
365GC-6	3/8	0.157	1.13
365GC-8	1/2	0.170	1.24

EGC Union Elbow (Metric)

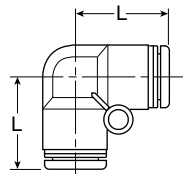

Part No.	Tube Size (mm)	Mounting Hole Dia. (mm)	L (mm)
EGC4	4	*	16.50
EGC6	6	3.50	19.30
EGC8	8	4.30	22.00
EGC10	10	4.00	28.70
EGC12	12	4.40	31.50

369GC Male Elbow

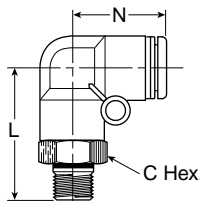

Part No.	Tube Size	Thread UNF	Mounting Hole Dia.	C Hex.	L	N
369GC-2-0	1/8	10-32	*	1/2	0.96	0.650
369GC-5/32-0	5/32	10-32	*	1/2	0.96	0.650
369GC-3-0	3/16	10-32	.138	9/16	1.09	0.760
369GC-4-0	1/4	10-32	.138	9/16	1.09	0.760

W369GC Male Elbow

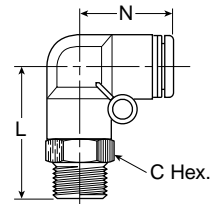

Part No.	Tube Size	Pipe Thread	Mounting Hole Dia.	C Hex.	L	N
W369GC-2-1	1/8	1/16	*	1/2	1.09	0.650
W369GC-2-2	1/8	1/8	*	1/2	1.10	0.650
W369GC-2-4	1/8	1/4	*	9/16	1.30	0.650
W369GC-5/32-1	5/32	1/16	*	1/2	1.09	0.650
W369GC-5/32-2	5/32	1/8	*	1/2	1.10	0.650
W369GC-5/32-4	5/32	1/4	*	9/16	1.30	0.650
W369GC-3-2	3/16	1/8	0.138	9/16	1.47	0.760
W369GC-3-4	3/16	1/4	0.138	9/16	1.43	0.760
W369GC-4-2	1/4	1/8	0.138	9/16	1.47	0.760
W369GC-4-4	1/4	1/4	0.138	9/16	1.43	0.760
W369GC-4-6	1/4	3/8	0.138	13/16	1.44	0.760
W369GC-5-2	5/16	1/8	0.169	5/8	1.26	0.866
W369GC-5-4	5/16	1/4	0.169	5/8	1.46	0.866
W369GC-5-6	5/16	3/8	0.169	13/16	1.50	0.866
W369GC-6-2	3/8	1/8	0.158	13/16	1.52	1.130
W369GC-6-4	3/8	1/4	0.158	13/16	1.72	1.130
W369GC-6-6	3/8	3/8	0.158	13/16	1.72	1.130
W369GC-6-8	3/8	1/2	0.158	15/16	1.94	1.130
W369GC-8-4	1/2	1/4	0.173	15/16	1.88	1.240
W369GC-8-6	1/2	3/8	0.173	15/16	1.89	1.240
W369GC-8-8	1/2	1/2	0.173	15/16	2.07	1.240

C63GC Male Elbow BSPT (Metric)

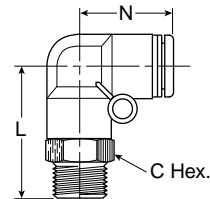

Part No.	Tube Size (mm)	BSPT Thread	Mounting Hole Dia. (mm)	C Hex. (mm)	L (mm)	N (mm)
C63GC4-1/8	4	1/8	*	12	24.9	16.5
C63GC4-1/4	4	1/4	*	14	24.9	16.5
C63GC4-3/8	4	3/8	*	17	27.9	16.5
C63GC6-1/8	6	1/8	3.5	14	27.7	13.0
C63GC6-1/4	6	1/4	3.5	14	29.7	13.0
C63GC6-3/8	6	3/8	3.5	17	31.7	13.0
C63GC8-1/8	8	1/8	4.3	17	29.0	22.0
C63GC8-1/4	8	1/4	4.3	17	31.0	22.0
C63GC8-3/8	8	3/8	4.3	17	33.0	22.0
C63GC8-1/2	8	1/2	4.3	22	35.0	22.0
C63GC10-1/4	10	1/4	4.0	21	36.5	28.7
C63GC10-3/8	10	3/8	4.0	21	37.5	28.7
C63GC10-1/2	10	1/2	4.0	22	40.5	28.7
C63GC12-1/4	12	1/4	4.4	22	40.7	31.5
C63GC12-3/8	12	3/8	4.4	22	41.7	31.5
C63GC12-1/2	12	1/2	4.4	22	43.7	31.5

All dimensions are preliminary and could change during final production. *Note 1/8", 5/32" and 4mm sizes do not have mounting holes.



C64GC Male Elbow BSPP (Metric)

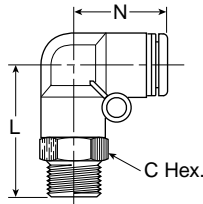

Part No.	Tube Size (mm)	BSPP Thread	Mounting Hole Dia. (mm)	C Hex. (mm)	L (mm)	N (mm)
C64GC4-1/8	4	1/8	*	12	26.9	16.5
C64GC4-1/4	4	1/4	*	17	30.9	16.5
C64GC4-3/8	4	3/8	*	21	32.9	16.5
C64GC6-1/8	6	1/8	3.5	14	29.3	13.0
C64GC6-1/4	6	1/4	3.5	17	33.3	13.0
C64GC6-3/8	6	3/8	3.5	21	33.3	13.0
C64GC8-1/8	8	1/8	4.3	17	30.0	22.0
C64GC8-1/4	8	1/4	4.3	17	34.0	22.0
C64GC8-3/8	8	3/8	4.3	21	34.0	22.0
C64GC8-1/2	8	1/2	4.3	24	36.0	22.0
C64GC10-1/4	10	1/4	4.0	21	40.5	28.7
C64GC10-3/8	10	3/8	4.0	21	40.5	28.7
C64GC10-1/2	10	1/2	4.0	24	42.5	28.7
C64GC12-1/4	12	1/4	4.4	22	41.7	31.5
C64GC12-3/8	12	3/8	4.4	22	41.7	31.5
C64GC12-1/2	12	1/2	4.4	24	45.7	31.5

370GC Female Elbow

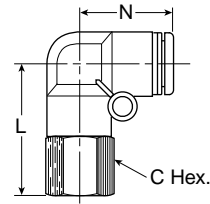

Part No.	Tube Size	Pipe Thread	Mounting Hole Dia.	C Hex.	L	N
370GC-2-2	1/8	1/8	*	1/2	0.98	0.650
370GC-2-4	1/8	1/4	*	5/8	1.14	0.650
370GC-5/32-2	5/32	1/8	*	1/2	0.98	0.650
370GC-5/32-4	5/32	1/4	*	5/8	1.14	0.650
370GC-3-4	3/16	1/4	0.138	9/16	1.23	0.760
370GC-4-2	1/4	1/8	0.138	9/16	1.08	0.760
370GC-4-4	1/4	1/4	0.138	5/8	1.23	0.760
370GC-4-6	1/4	3/8	0.138	13/16	1.27	0.760
370GC-5-2	5/16	1/8	0.173	5/8	1.14	0.866
370GC-5-4	5/16	1/4	0.173	5/8	1.30	0.866
370GC-6-2	3/8	1/8	0.157	13/16	1.36	1.130
370GC-6-4	3/8	1/4	0.157	13/16	1.52	1.130
370GC-6-6	3/8	3/8	0.157	13/16	1.56	1.130
370GC-6-8	3/8	1/2	0.157	15/16	1.70	1.130
370GC-8-6	1/2	3/8	0.173	15/16	1.68	1.240
370GC-8-8	1/2	1/2	1.730	15/16	2.27	1.240

C68GC Male Elbow Metric Thread

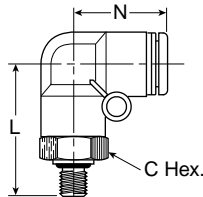

Part No.	Tube Size (mm)	Metric Thread	Mounting Hole Dia. (mm)	C Hex. (mm)	L (mm)	N (mm)
C68GC4M5	4	M5	•	12	26.9	16.5
C68GC4M6	4	M6	•	12	26.9	16.5
C68GC6M5	6	M5	3.5	14	29.3	19.3
C68GC6M6	6	M6	3.5	14	29.3	19.3

CF63GC Female Elbow BSPT (Metric)

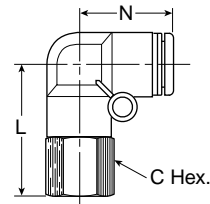

Part No.	Tube Size (mm)	BSPT Thread	Mounting Hole Dia. (mm)	C Hex. (mm)	L (mm)	N (mm)
CF63GC4-1/8	4	1/8	*	12	24.5	16.5
CF63GC4-1/4	4	1/4	*	17	25.9	16.5
CF63GC4-3/8	4	3/8	*	21	26.4	16.5
CF63GC6-1/8	6	1/8	3.5	14	28.8	19.3
CF63GC6-1/4	6	1/4	3.5	17	28.8	19.3
CF63GC6-3/8	6	3/8	3.5	21	28.8	19.3
CF63GC8-1/8	8	1/8	4.3	17	31.0	22.0
CF63GC8-1/4	8	1/4	4.3	17	31.0	22.0
CF63GC8-3/8	8	3/8	4.3	21	32.0	22.0
CF63GC8-1/2	8	1/2	4.3	22	32.0	22.0
CF63GC10-1/4	10	1/4	4.0	21	36.5	28.7
CF63GC10-3/8	10	3/8	4.0	21	37.5	28.7
CF63GC10-1/2	10	1/2	4.0	24	37.5	28.7
CF63GC12-1/4	12	1/4	4.4	22	40.7	31.5
CF63GC12-3/8	12	3/8	4.4	22	40.7	31.5
CF63GC12-1/2	12	1/2	4.4	24	51.2	31.5

All dimensions are preliminary and could change during final production. *Note 1/8", 5/32" and 4mm sizes do not have mounting holes.

F



CF68GC Female Elbow (Metric)

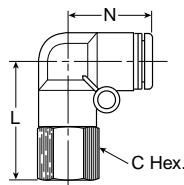

Part No.	Tube Size (mm)	Metric Thread	Mounting Hole Dia. (mm)	C Hex. (mm)	L (mm)	N (mm)
CF68GC4M5	4	M5	*	12	23.0	16.5
CF68GC4M6	4	M6	*	12	23.0	16.5
CF68GC6M5	6	M5	3.5	14	25.3	19.3
CF68GC6M6	6	M6	3.5	14	25.3	19.3

371GC Male Run Tee Swivel

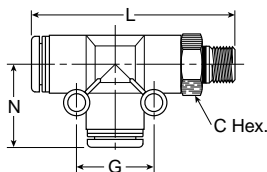

Part No.	Tube Size	Thread UNF	Mounting Hole Dia.	C Hex.	L	N	G
371GC-5/32-0	5/32	10-32	*	1/2	1.71	0.689	*
371GC-4-0	1/4	10-32	0.138	9/16	1.81	0.740	0.63

W371GC Male Run Tee Swivel

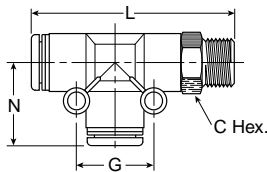

Part No.	Tube Size	Thread UNF	Mounting Hole Dia.	C Hex.	L	N	G
W371GC-2-1	1/8	1/16	*	1/2	1.86	0.689	*
W371GC-2-2	1/8	1/8	*	1/2	1.86	0.689	*
W371GC-2-4	1/8	1/4	*	9/16	2.06	0.689	*
W371GC-5/32-1	5/32	1/16	*	1/2	1.85	0.689	*
W371GC-5/32-2	5/32	1/8	*	1/2	1.85	0.689	*
W371GC-5/32-4	5/32	1/4	*	9/16	2.05	0.689	*
W371GC-3-2	3/16	1/8	0.138	9/16	1.94	0.740	0.630
W371GC-3-4	3/16	1/4	0.138	9/16	2.15	0.740	0.630
W371GC-4-2	1/4	1/8	0.138	9/16	1.94	0.740	0.630
W371GC-4-4	1/4	1/4	0.138	9/16	2.15	0.740	0.630
W371GC-4-6	1/4	3/8	0.138	13/16	2.19	0.740	0.630
W371GC-5-2	5/16	1/8	0.173	5/8	2.21	0.906	0.811
W371GC-5-4	5/16	1/4	0.173	5/8	2.41	0.906	0.811
W371GC-5-6	5/16	3/8	0.173	13/16	2.46	0.906	0.811
W371GC-6-2	3/8	1/8	0.165	13/16	2.61	1.122	0.921
W371GC-6-4	3/8	1/4	0.165	13/16	2.80	1.122	0.921
W371GC-6-6	3/8	3/8	0.165	13/16	2.81	1.122	0.921
W371GC-6-8	3/8	1/2	0.165	15/16	3.03	1.122	0.921
W371GC-8-4	1/2	1/4	0.165	15/16	2.89	1.142	1.035
W371GC-8-6	1/2	3/8	0.165	15/16	2.90	1.142	1.035
W371GC-8-8	1/2	1/2	0.165	15/16	3.12	1.142	1.035

R63GC Male Run Tee BSPT (Metric)

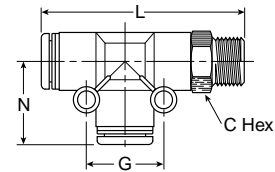

Part No.	Tube Size (mm)	BSPT Thread	Mounting Hole Dia. (mm)	C Hex. (mm)	L (mm)	N (mm)	G (mm)
R63GC4-1/8	4	1/8	*	12	43.9	17.5	*
R63GC4-1/4	4	1/4	*	14	45.9	17.5	*
R63GC4-3/8	4	3/8	*	17	47.9	17.5	*
R63GC6-1/8	6	1/8	3.5	14	46.3	18.8	16.0
R63GC6-1/4	6	1/4	3.5	14	48.3	18.8	16.0
R63GC6-3/8	6	3/8	3.5	17	50.3	18.8	16.0
R63GC8-1/8	8	1/8	4.4	17	53.2	23.0	20.6
R63GC8-1/4	8	1/4	4.4	17	55.2	23.0	20.6
R63GC8-3/8	8	3/8	4.4	17	57.2	23.0	20.6
R63GC8-1/2	8	1/2	4.4	22	59.2	23.0	20.6
R63GC10-1/4	10	1/4	4.2	21	64.2	28.5	23.4
R63GC10-3/8	10	3/8	4.2	21	65.2	28.5	23.4
R63GC10-1/2	10	1/2	4.2	22	68.2	28.5	23.4
R63GC12-1/4	12	1/4	4.2	22	67.0	29.0	26.3
R63GC12-3/8	12	3/8	4.2	22	68.0	29.0	26.3
R63GC12-1/2	12	1/2	4.2	22	70.0	29.0	26.3

R68GC Male Run Tee Metric Thread

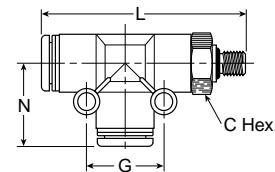

Part No.	Tube Size (mm)	BSPT Thread	Mounting Hole Dia. (mm)	C Hex. (mm)	L (mm)	N (mm)	G (mm)
R68GC4M5	4	M5	*	12	46.0	17.5	*
R68GC4M6	4	M6	*	12	46.0	17.5	*
R68GC6M5	6	M5	3.5	14	48.3	18.8	16.0
R68GC6M6	6	M6	3.5	14	48.3	18.8	16.0

372GC Male Branch Tee Swivel

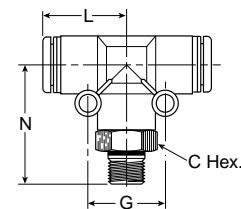

Part No.	Tube Size	Pipe Thread	Mounting Hole Dia.	C Hex.	L	N	G
372GC-2-0	1/8	10-32	*	1/2	1.32	1.00	*
372GC-5/32-0	5/32	10-32	*	1/2	1.32	1.00	*
372GC-4-0	1/4	10-32	0.138	9/16	1.38	1.04	0.63

All dimensions are preliminary and could change during final production. *Note 1/8", 5/32" and 4mm sizes do not have mounting holes.



W372GC Male Branch Tee Swivel

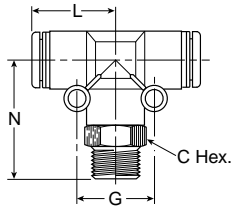

Part No.	Tube Size	Pipe Thread	Mounting Hole Dia.	C Hex.	L	N	G
W372GC-2-2	1/8	1/8	*	1/2	1.36	1.14	*
W372GC-2-4	1/8	1/4	*	9/16	1.56	1.34	*
W372GC-5/32-2	5/32	1/8	*	1/2	1.36	1.14	*
W372GC-3-2	3/16	1/8	0.138	9/16	1.44	1.17	0.630
W372GC-3-4	3/16	1/4	0.138	9/16	1.62	1.38	0.630
W372GC-4-2	1/4	1/8	0.138	9/16	1.44	1.17	0.630
W372GC-4-4	1/4	1/4	0.138	9/16	1.62	1.38	0.630
W372GC-4-6	1/4	3/8	0.138	13/16	1.64	1.42	0.630
W372GC-5-2	5/16	1/8	0.173	5/8	1.61	1.31	0.811
W372GC-5-4	5/16	1/4	0.173	5/8	1.82	1.51	0.811
W372GC-5-6	5/16	3/8	0.173	13/16	1.81	1.56	0.811
W372GC-6-2	3/8	1/8	0.165	13/16	1.88	1.50	0.921
W372GC-6-4	3/8	1/4	0.165	13/16	2.04	1.70	0.921
W372GC-6-6	3/8	3/8	0.165	13/16	2.04	1.71	0.921
W372GC-6-8	3/8	1/2	0.165	15/16	2.27	1.93	0.921
W372GC-8-4	1/2	1/4	0.165	15/16	2.15	1.74	1.035
W372GC-8-6	1/2	3/8	0.165	15/16	2.16	1.74	1.035
W372GC-8-8	1/2	1/2	0.165	15/16	2.36	1.96	1.035

S63GC Male Branch Tee BSPT (Metric)

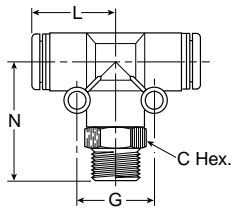

Part No.	Tube Size (mm)	BSPT Thread	Mounting Hole Dia. (mm)	C Hex. (mm)	L (mm)	N (mm)	G (mm)
S63GC4-1/8	4	1/8	*	12	35.0	26.0	*
S63GC4-1/4	4	1/4	*	14	35.0	28.0	*
S63GC4-3/8	4	3/8	*	17	35.0	30.0	*
S63GC6-1/8	6	1/8	3.5	14	37.6	26.8	16.0
S63GC6-1/4	6	1/4	3.5	14	37.6	28.8	16.0
S63GC6-3/8	6	3/8	3.5	17	37.6	30.8	16.0
S63GC8-1/8	8	1/8	4.4	17	46.0	30.2	20.6
S63GC8-1/4	8	1/4	4.4	17	46	32.2	20.6
S63GC8-3/8	8	3/8	4.4	17	46	34.2	20.6
S63GC8-1/2	8	1/2	4.4	22	46	36.2	20.6
S63GC10-1/4	10	1/4	4.2	21	57	36.2	23.4
S63GC10-3/8	10	3/8	4.2	21	57	37.2	23.4
S63GC10-1/2	10	1/2	4.2	22	57	40.2	23.4
S63GC12-1/4	12	1/4	4.2	22	58	38.0	26.3
S63GC12-3/8	12	3/8	4.2	22	58	39.0	26.3
S63GC12-1/2	12	1/2	4.2	22	58	41.0	26.3

S68GC Male Branch Tee Metric Thread

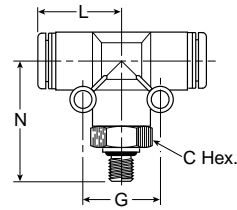

Part No.	Tube Size (mm)	BSPT Thread	Mounting Hole Dia. (mm)	C Hex. (mm)	L (mm)	N (mm)	G (mm)
S68GC4M5	4	M5	*	12	35.0	28.0	*
S68GC4M6	4	M6	*	12	35.0	28.0	*
S68GC6M5	6	M5	3.5	14	37.6	28.8	16.0
S68GC6M6	6	M6	3.5	14	37.6	28.8	16.0

362GC Union Y Connector

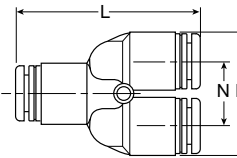

Part No.	Tube Size	Mounting Hole Dia.	L	M	N
362GC-2	1/8	0.118	1.358	0.421	0.846
362GC-5/32	5/32	0.118	1.358	0.421	0.846
362GC-3	3/16	0.129	1.417	0.531	1.063
362GC-4	1/4	0.150	1.450	0.561	1.100
362GC-5	5/16	0.150	1.693	0.591	1.201
362GC-6	3/8	0.165	1.969	0.728	1.457
362GC-8	1/2	0.173	2.256	0.807	1.646

YJGC Union Y Connector (Metric)

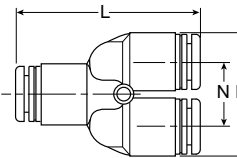

Part No.	Tube Size (mm)	Mounting Hole Dia. (mm)	L (mm)	M (mm)	N (mm)
YJGC4	4	3.0	34.5	21.5	10.7
YJGC6	6	3.4	36.0	27.0	13.5
YJGC8	8	3.8	43.0	30.5	15.0
YJGC10	10	4.2	50.8	37.0	18.5
YJGC12	12	4.4	57.8	41.5	20.5

All dimensions are preliminary and could change during final production. *Note 1/8", 5/32" and 4mm sizes do not have mounting holes.

F



W368GC Union Y Male Connector

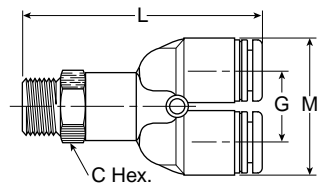

Part No.	Tube Size	Pipe Thread	Mounting Hole Dia.	C Hex.	L	G	M
W368GC-2-2	1/8	1/8	0.118	1/2	1.84	0.433	0.854
W368GC-2-4	1/8	1/4	0.118	9/16	2.04	0.433	0.854
W368GC-3-2	3/16	1/8	0.134	9/16	1.89	0.531	1.063
W368GC-3-4	3/16	1/4	0.134	9/16	2.09	0.531	1.063
W368GC-5/32-2	5/32	1/8	0.118	1/2	1.83	0.433	0.854
W368GC-5/32-4	5/32	1/4	0.118	9/16	2.03	0.433	0.854
W368GC-4-2	1/4	1/8	0.134	9/16	1.89	0.531	1.063
W368GC-4-4	1/4	1/4	0.134	9/16	2.09	0.531	1.063
W368GC-4-6	1/4	3/8	0.134	13/16	2.10	0.531	1.063
W368GC-5-2	5/16	1/8	0.150	5/8	2.07	0.590	1.201
W368GC-5-4	5/16	1/4	0.150	5/8	2.28	0.590	1.201
W368GC-6-2	3/8	1/8	0.165	13/16	2.36	0.728	1.457
W368GC-6-4	3/8	1/4	0.165	13/16	2.57	0.728	1.457
W368GC-6-6	3/8	3/8	0.165	13/16	2.57	0.728	1.457
W368GC-6-8	3/8	1/2	0.173	15/16	2.79	0.728	1.457
W368GC-8-4	1/2	1/4	0.173	15/16	2.91	0.807	1.654
W368GC-8-6	1/2	3/8	0.173	15/16	2.92	0.807	1.654
W368GC-8-8	1/2	1/2	0.173	15/16	3.11	0.807	1.654

YJ68GC Union Y Male Connector Metric Thread

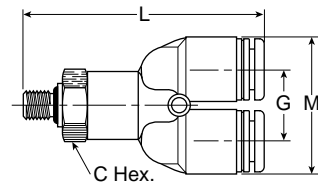

Part No.	Tube Size (mm)	Metric Thread	Mounting Hole Dia. (mm)	C Hex. (mm)	L (mm)	G (mm)	M (mm)
YJ68GC4M5	4	M5	3.0	12	43.4	11.0	21.5
YJ68GC4M6	4	M6	3.0	12	43.4	11.0	21.5
YJ68GC6M5	4	M5	3.4	14	44.2	13.5	27.0
YJ68GC6M6	6	M6	3.4	14	44.2	13.5	27.0

YJ63GC Union Y Male Connector BSPT (Metric)

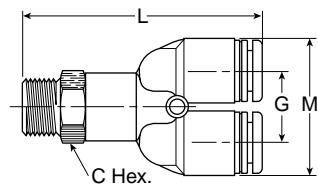

Part No.	Tube Size (mm)	BSPT Thread	Mounting Hole Dia. (mm)	C Hex. (mm)	L (mm)	G (mm)	M (mm)
YJ63GC4-1/8	4	1/8	3.0	12	43.4	11.0	21.5
YJ63GC4-1/4	4	1/4	3.0	14	45.4	11.0	21.5
YJ63GC4-3/8	4	3/8	3.0	17	47.4	11.0	21.5
YJ63GC6-1/8	6	1/8	3.4	14	44.2	13.5	27.0
YJ63GC6-1/4	6	1/4	3.4	14	46.2	13.5	27.0
YJ63GC6-3/8	6	3/8	3.4	17	48.2	13.5	27.0
YJ63GC8-1/8	8	1/8	3.8	17	50.0	15.0	30.5
YJ63GC8-1/4	8	1/4	3.8	17	52.0	15.0	30.5
YJ63GC8-3/8	8	3/8	3.8	17	54.0	15.0	30.5
YJ63GC8-1/2	8	1/2	3.8	22	56.0	15.0	30.5
YJ63GC10-1/4	10	1/4	4.2	21	58.3	18.5	37.0
YJ63GC10-3/8	10	3/8	4.2	21	59.3	18.5	37.0
YJ63GC10-1/2	10	1/2	4.2	22	62.3	18.5	37.0
YJ63GC12-1/4	12	1/4	4.4	22	66.8	20.5	41.5
YJ63GC12-3/8	12	3/8	4.4	22	67.8	20.5	41.5
YJ63GC12-1/2	12	1/2	4.4	22	69.8	20.5	41.5

All dimensions are preliminary and could change during final production.



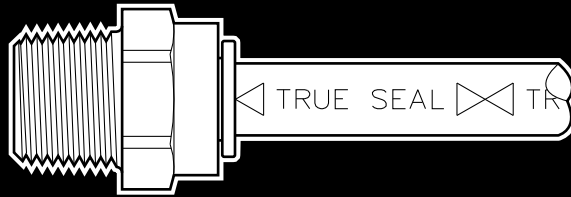

TrueSeal™ Thermoplastic Push-In Fittings

The patented* TrueSeal™ push-to-connect thermoplastic fittings are light weight, Field Attachable, and connect to plastic tubing without the use of tools.

Features

- All components in TrueSeal™ fittings are manufactured from FDA compliant materials and are NSF-51 listed for contact with food.
- Gray acetal TrueSeal™ fittings meet NSF-61 requirements for drinking water (potable water) system components.
- All-plastic body designs offer reduced weight, eliminate rust, corrosion, and system contamination in applications where metal components cannot be tolerated.
- Collets are offered in either a patented all-plastic design for use with flexible tubing or with a metal grip edge made from 300 series stainless steel for use on all tubing including copper.
- Extra deep tube seat in fitting body provides support to reduce side-load leakage.
- Elastomer o-ring seal provides positive compression on tubing O.D. in vacuum or pressure applications.
- Removable collet design permits o-ring replacement in the field. Collets are available in colors for easy color coding of systems.
- Tube stem adapters provide a wide range of tube-to-port jump size potential and allow elbows and tees to swivel for positive tube routing alignment. Connections made with metal gripper collets, may require tube stems to be replaced upon reconnection.

Applications

TrueSeal™ fittings find wide acceptance in water conditioning, filtration, and reverse osmosis industries and on water, soft drink, beer, wine, and condiment dispensing equipment. Industrial applications range from vacuum to low-pressure hydraulic and pneumatic systems on robotics, air logic, packaging / filling equipment, and conveyors. Ink and dye transfer, lubrication and cooling lines on presses, machine tools, ion implanting devices—all rely on TrueSeal™.

Standard Materials

Materials	Fitting Color	O-ring
Acetal	Gray	EPDM
Polypropylene	White	EPDM
Kynar®	Natural	Fluorocarbon

Black nitrile o-rings and colored collets in black, white, red, blue, green, yellow and orange are also available. Consult Division.
 KYNAR® is a registered trademark of Atochem North America, Inc.
 *U.S. Patent 5,584,513

Note: Provide adequate fail-safe mechanisms such as leakage detection sensors, automatic shut-off controls or other industry and code appropriate fail-safe devices in the design of your water-handling appliance to protect against personal injury and property damage. Plastic fittings containing an o-ring have a finite life depending on the environment, media and severity of the application. Frequent inspections and replacement of the fitting when anomalies are found is recommended.

How to Order

A 4 MC 4 - MG - V

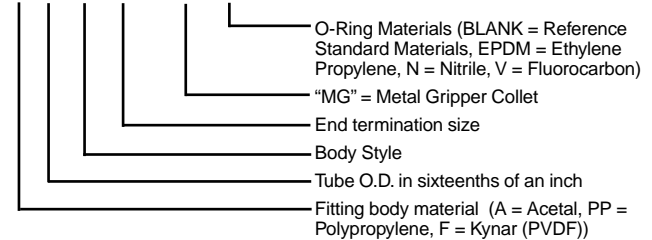

Working Pressure

TrueSeal™ fittings are rated for the pressures listed below or at 1/4 (one-fourth) of the rated burst pressure of the tubing being used (whichever is less).

Fitting Size	Acetal	Polypropylene	Kynar®
1/4"	300	150	300
5/16"	300	—	—
3/8"	300	150	300
1/2"	250	150	—
Temp. Range	-20°F (-29°C) to 180°F (85°C)	-20°F (-29°C) to 225°F (110°C)	-20°F (-29°C) to 275°F (135°C)

- These pressure ratings are based on tests conducted with Series NR tubing at 73°F.
- Actual working pressures will be lower at elevated temperatures. Consult division.
- Meets pressure integrity tests of NSF-53 and NSF-58

Tubing

Parker TrueSeal™ fittings with all plastic collets can be used with the following tubing materials: polyethylene, polypropylene, nylon, vinyl, fluoropolymer, and polyurethane (3/8" and 1/2" polyurethane and all sizes of vinyl should use tube supports). TrueSeal™ fittings with metal gripper collets can be used with tubing listed above and soft copper tubing. For stainless steel or glass tubing or all other metal tubing, consult factory.

Tube Sizes	O.D. Tolerance	Insertion Depth
5/32"	±.005"	9/16"
1/4"	±.005"	11/16"
5/16"	±.005"	13/16"
3/8"	±.005"	3/4"
1/2"	±.005"	7/8"

Assembly Instructions

1. Cut tubing square and clean. (Use a Parker plastic tube cutter, Part No. PTC.)
2. Mark from end of tube the length of insertion (see table above).
3. Push tube into the fitting until it bottoms out.
4. To remove, depress collet and pull tubing out.
5. Use TrueSealant™ (Part No. PTS) on threads.

F



MC Male Connector Tube-to-Pipe

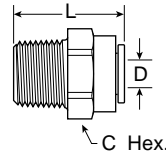

Gray Acetal EPDM Seal	White Polypropylene EPDM Seal	Natural Kynar Fluoro-carbon Seal	Nom. Tube O.D.	NPTF Thread Size	C Hex.	L Overall Length	D Thru Hole Min.
A4MC2-MG	PP4MC2	F4MC2	1/4	1/8	11/16	1.28	0.175
A4MC4-MG	PP4MC4	F4MC4	1/4	1/4	11/16	1.14	0.175
A4MC6-MG	PP4MC6	F4MC6	1/4	3/8	11/16	1.18	0.175
A5MC2-MG	—	—	5/16	1/8	13/16	1.46	0.175
A5MC4-MG	—	—	5/16	1/4	13/16	1.41	0.188
A5MC6-MG	—	—	5/16	3/8	13/16	1.27	0.188
A6MC2-MG	—	F6MC2	3/8	1/8	13/16	1.46	0.175
A6MC4-MG	PP6MC4	F6MC4	3/8	1/4	13/16	1.41	0.250
A6MC6-MG	PP6MC6	F6MC6	3/8	3/8	13/16	1.27	0.250
A6MC8-MG	—	F6MC8	3/8	1/2	15/16	1.45	0.250
A8MC6-MG	PP8MC6	—	1/2	3/8	15/16	1.65	0.360
A8MC8-MG	PP8MC8	—	1/2	1/2	15/16	1.46	0.375

For nonstandard plastic collet, remove -MG suffix.

EU Union Elbow Tube-to-Tube

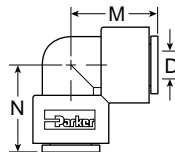

Gray Acetal EPDM Seal	White Polypropylene EPDM Seal	Natural Kynar Fluoro-carbon Seal	Nom. Tube O.D.	M	N	D Thru Hole Min.
A4EU4-MG	PP4EU4	F4EU4	1/4	0.87	0.87	0.175
A5EU4-MG	—	—	5/16-1/4	1.052	0.90	0.175
A5EU5-MG	—	—	5/16	1.02	1.02	0.188
A6EU4-MG	PP6EU4	F6EU4	3/8-1/4	1.02	0.90	0.212
A6EU5-MG	—	—	3/8-5/16	1.02	1.02	0.175
A6EU6-MG	PP6EU6	F6EU6	3/8	1.02	1.02	0.250
A8EU6-MG	—	—	1/2-3/8	1.20	1.20	0.250
A8EU8-MG	PP8EU8	—	1/2	1.20	1.20	0.375

For nonstandard plastic collet, remove -MG suffix.

TU Union Tee Tube-to-Tube

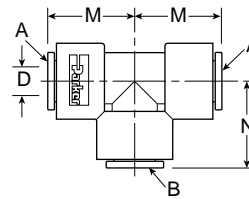

Gray Acetal EPDM Seal	White Polypropylene EPDM Seal	Natural Kynar Fluoro-carbon Seal	Nom. Tube O.D. Tube A Run	Tube B Stem	M	N	D Thru Hole Min.
A4TU4-MG	PP4TU4	F4TU4	1/4	1/4	0.81	0.85	0.175
A5TU5-MG	—	—	5/16	5/16	1.02	1.02	0.188
A6TU4-MG	PP6TU4	F6TU4	3/8	1/4	1.02	1.03	0.175
A6TU6-MG	PP6TU6	F6TU6	3/8	3/8	1.02	1.02	0.290
A8TU8-MG	PP8TU8	—	1/2	1/2	1.20	1.20	0.375

For nonstandard plastic collet, remove -MG suffix.

WY Union Y Tube-to-Tube

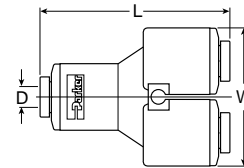

Gray Acetal EPDM Seal	White Polypropylene EPDM Seal	Natural Kynar Fluoro-carbon Seal	Nom. Tube O.D. Inlet Tube A Run	Outlet Tube B Stem	L	W	D Thru Hole Min.
A5WY5-MG	—	—	5/16	5/16	2.250	1.75	0.190
A6WY4-MG	—	—	3/8	1/4	2.100	1.43	0.190
A6WY5-MG	—	—	3/8	5/16	2.200	1.75	0.190
A6WY6-MG	—	—	3/8	3/8	2.175	1.75	0.250



MES Male Elbow Swivel (Tube-to-Pipe)

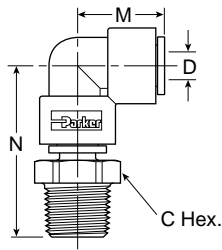

Gray Acetal EPDM Seal	White Polypropylene EPDM Seal	Natural Kynar Fluoro-carbon Seal	Nom. Tube O.D.	NPTF Thread Size	C Hex	M	N	D Thru Hole Min.
A4MES2-MG	PP4MES2	F4MES2	1/4	1/8	9/16	0.87	1.60	0.175
A4MES4-MG	PP4MES4	F4MES4	1/4	1/4	11/16	0.87	1.71	0.175
A4MES6-MG	PP4MES6	F4MES6	1/4	3/8	13/16	0.90	1.91	0.212
A5MES2-MG	—	—	5/16	1/8	9/16	1.02	1.78	0.188
A5MES4-MG	—	—	5/16	1/4	11/16	1.02	1.90	0.188
A5MES6-MG	—	—	5/16	3/8	13/16	1.02	1.90	0.188
A6MES2-MG	—	F6MES2	3/8	1/8	9/16	1.02	1.65	0.175
A6MES4-MG	PP6MES4	F6MES4	3/8	1/4	13/16	1.02	1.90	0.250
A6MES6-MG	PP6MES6	F6MES6	3/8	3/8	13/16	1.02	1.90	0.250
A8MES4-MG	—	—	1/2	1/4	13/16	1.20	2.10	0.240
A8MES6-MG	PP8MES6	—	1/2	3/8	13/16	1.20	2.10	0.375
A8MES8-MG	PP8MES8	—	1/2	1/2	1	1.20	2.32	0.375

*Part consists of elbow union and tube stem adaptor.
 Note: Assemblies with metal gripper collets are permanent.
 Assemblies with plastic collets can be taken apart.

MTS Male Tee Swivel (Tube-to-Pipe)

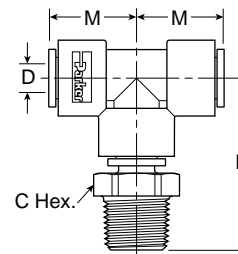

Gray Acetal EPDM Seal	White Polypropylene EPDM Seal	Natural Kynar Fluoro-carbon Seal	Nom. Tube O.D.	NPTF Thread Size	C Hex	M	N	D Thru Hole Min.
A4MTS2-MG	PP4MTS2	F4MTS2	1/4	1/8	9/16	0.81	1.60	0.175
A4MTS4-MG	PP4MTS4	F4MTS4	1/4	1/4	11/16	0.81	1.71	0.175
A5MTS2-MG	—	—	5/16	1/8	9/16	1.02	1.78	0.188
A5MTS4-MG	—	—	5/16	1/4	11/16	1.02	1.90	0.188
A5MTS6-MG	—	—	5/16	3/8	13/16	1.02	1.90	0.188
A6MTS2-MG	—	F6MTS2	3/8	1/8	9/16	1.02	1.75	0.175
A6MTS4-MG	PP6MTS4	F6MTS4	3/8	1/4	13/16	1.02	1.90	0.250
A6MTS6-MG	PP6MTS6	F6MTS6	3/8	3/8	13/16	1.02	1.90	0.250
A8MTS4-MG	—	—	1/2	1/4	13/16	1.20	2.10	0.240
A8MTS6-MG	PP8MTS6	—	1/2	3/8	13/16	1.20	2.10	0.375
A8MTS8-MG	PP8MTS8	—	1/2	1/2	1	1.20	2.32	0.375

*Part consists of tee union and tube stem adaptor.
 Note: Assemblies with metal gripper collets are permanent.
 Assemblies with plastic collets can be taken apart.

MRS Male Run Swivel (Tube-to-Pipe)

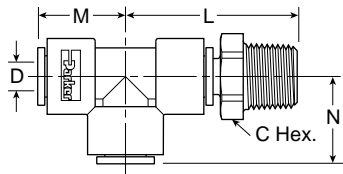

Gray Acetal EPDM Seal	White Polypropylene EPDM Seal	Natural Kynar Fluoro-carbon Seal	Nom. Tube O.D.	NPTF Thread Size	C Hex	L	M	N	D Thru Hole Min.
A4MRS2-MG	PP4MRS2	F4MRS2	1/4	1/8	9/16	1.55	0.81	0.85	0.175
A4MRS4-MG	PP4MRS4	F4MRS4	1/4	1/4	11/16	1.67	0.81	0.85	0.175
A5MRS2-MG	—	—	5/16	1/8	9/16	1.78	1.02	1.02	0.188
A5MRS4-MG	—	—	5/16	1/4	11/16	1.90	1.02	1.02	0.188
A5MRS6-MG	—	—	5/16	3/8	13/16	1.90	1.02	1.02	0.188
A6MRS4-MG	PP6MRS4	F6MRS4	3/8	1/4	13/16	1.90	1.02	1.02	0.250
A6MRS6-MG	PP6MRS6	F6MRS6	3/8	3/8	13/16	1.90	1.02	1.02	0.250
A8MRS4-MG	—	—	1/2	1/4	13/16	2.10	1.20	1.20	0.240
A8MRS6-MG	PP8MRS6	—	1/2	3/8	13/16	2.10	1.20	1.20	0.375
A8MRS8-MG	PP8MRS8	—	1/2	1/2	1	2.32	1.20	1.20	0.375

*Part consists of tee union and tube stem adaptor.
 Note: Assemblies with metal gripper collets are permanent.
 Assemblies with plastic collets can be taken apart.

UC Union Connector (Tube-to-Pipe)

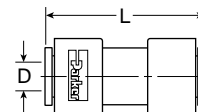

Gray Acetal EPDM Seal	White Polypropylene EPDM Seal	Natural Kynar Fluoro-carbon Seal	Nom. Tube O.D.	L Overall Length	D Thru Hole Min.
A4UC4-MG	PP4UC4	F4UC4	1/4	1.49	0.175
A5UC4-MG	—	—	5/16-1/4	1.70	0.175
A5UC5-MG	—	—	5/16	1.70	0.188
A6UC4-MG	PP6UC4	F6UC4	3/8-1/4	1.70	0.175
A6UC5-MG	—	—	3/8-5/16	1.70	0.188
A6UC6-MG	PP6UC6	F6UC6	3/8	1.70	0.250
A8UC5-MG	—	—	1/2-5/16	1.90	0.188
A8UC6-MG	PP8UC6	—	1/2-3/8	1.90	0.250
A8UC8-MG	PP8UC8	—	1/2	1.91	0.375

For nonstandard plastic collet, remove -MG suffix.

F



CU Cross Union (Tube-to-Pipe)

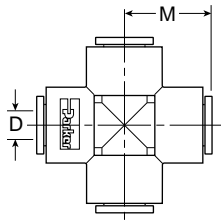

Gray Acetal EPDM Seal	White Polypropylene EPDM Seal	Natural Kynar Fluoro-carbon Seal	Nom. Tube O.D.	M	D Thru Hole Min.
A4CU4-MG	—	—	1/4	0.91	0.175
A6CU6-MG	—	—	3/8	1.08	0.250

For nonstandard plastic collet, remove -MG suffix.

FA Faucet Adapter (Tube-to-Faucet)

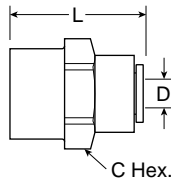

Gray Acetal EPDM Seal	White Polypropylene EPDM Seal	Natural Kynar Fluoro-carbon Seal	Nom. Tube O.D.	UNS-2B Thread Size	C Hex	L Overall Length	D Thru Hole Min.
A4FA7-MG	PP4FA7	F4FA7	1/4	7/16-24	23/32	1.32	0.190
A5FA7-MG	—	—	5/16	7/16-24	13/16	1.41	0.190
A6FA7-MG	PP6FA7	F6FA7	3/8	7/16-24	13/16	1.41	0.190

For nonstandard plastic collet, remove -MG suffix.

FC Female Connector (Tube-to-Pipe)

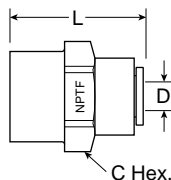

Gray Acetal EPDM Seal	White Polypropylene EPDM Seal	Natural Kynar Fluoro-carbon Seal	Nom. Tube O.D.	NPTF Thread Size	C Hex	L Overall Length	D Thru Hole Min.
A4FC2-MG	PP4FC2	F4FC2	1/4	1/8	11/16	1.20	.175
A4FC4-MG	PP4FC4	F4FC4	1/4	1/4	23/32	1.32	.175
A5FC4-MG	—	—	5/16	1/4	13/16	1.41	.188
A5FC6-MG	—	—	5/16	3/8	1	1.50	.188
A6FC4-MG	PP6FC4	F6FC4	3/8	1/4	13/16	1.41	.250
A6FC6-MG	PP6FC6	F6FC6	3/8	3/8	1	1.50	.250
A6FC8-MG	—	—	3/8	1/2	1-1/8	1.52	.250
A8FC6-MG	PP8FC6	—	1/2	3/8	1-1/8	1.60	.375
A8FC8-MG	PP8FC8	—	1/2	1/2	1-1/8	1.75	.375

For nonstandard plastic collet, remove -MG suffix.

FF 45° Female Flare (Tube-to-Pipe)

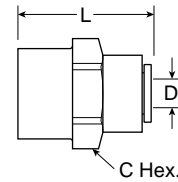

Gray Acetal EPDM Seal	White Polypropylene EPDM Seal	Natural Kynar Fluoro-carbon Seal	Nom. Tube O.D.	UNF-2B Thread Size	C Hex	L Overall Length	D Thru Hole Min.
A4FF4-MG	PP4FF4	F4FF4	1/4	7/16-20	23/32	1.32	0.190
A6FF4-MG	—	F6FF4	3/8	7/16-20	13/16	1.41	0.190
A6FF6-MG	PP6FF6	F6FF6	3/8	5/8-18	1	1.50	0.250

For nonstandard plastic collet, remove -MG suffix.

TMC Tube Stem Adapter (Tube Stem-to-Pipe)

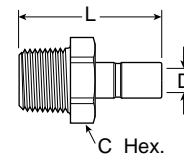

Gray Acetal EPDM Seal	White Polypropylene EPDM Seal	Natural Kynar Fluoro-carbon Seal	Nom. Tube O.D.	NPTF Thread Size	C Hex	L Overall Length	D Thru Hole Min.
A4TMC2	PP4TMC2	F4TMC2	1/4	1/8	9/16	1.44	0.175
A4TMC4	PP4TMC4	F4TMC4	1/4	1/4	11/16	1.56	0.175
A5TMC2	—	—	5/16	1/8	9/16	1.5	0.188
A5TMC4	—	—	5/16	1/4	11/16	1.67	0.188
A5TMC6	—	—	5/16	3/8	13/16	1.67	0.188
A6TMC4	PP6TMC4	F6TMC4	3/8	1/4	13/16	1.70	0.250
A6TMC6	PP6TMC6	F6TMC6	3/8	3/8	13/16	1.70	0.250
A8TMC4	—	—	1/2	1/4	13/16	1.82	0.240
A8TMC6	PP8TMC6	—	1/2	3/8	13/16	1.82	0.375
A8TMC8	PP8TMC8	—	1/2	1/2	1	2.04	0.375



BU Bulkhead Union (Tube-to-Tube)

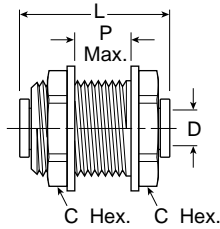

Gray Acetal EPDM Seal	White Polypropylene EPDM Seal	Natural Kynar Fluorocarbon Seal	Nom. Tube O.D.	C1 Hex	C2 Hex	L Overall Length	P Max. Wall Thk.	D Thru Hole Min.	Bulkhead Drill Size
A4BU4-MG	PP4BU4	F4BU4	1/4	15/16	15/16	1.50	0.50	0.175	7/8
A5BU5-MG	—	—	5/16	1-1/16	1-1/16	1.75	0.62	0.188	1
A6BU4-MG	PP6BU4	—	3/8-1/4	1-1/16	1-1/16	1.75	0.62	0.175	1
A6BU6-MG	PP6BU6	F6BU6	3/8	1-1/16	1-1/16	1.75	0.62	0.250	1
A8BU8-MG	—	—	1/2	1-1/4	1-1/4	2.04	0.70	0.375	1-1/8

For nonstandard plastic collet, remove -MG suffix.

TEU Tube Elbow Union (Tube-to-Tube Stem)

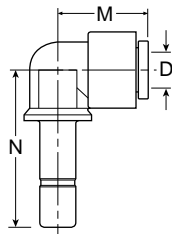

Gray Acetal EPDM Seal	White Polypropylene EPDM Seal	Natural Kynar Fluorocarbon Seal	Nom. Tube O.D.	Tube Stem O.D.	M	N	D Thru Hole Min.
A4TEU4-MG	PP4TEU4	F4TEU4	1/4	1/4	.84	1.21	0.125
A4TEU6-MG	—	F4TEU6	1/4	3/8	.84	1.35	0.125
A5TEU5-MG	—	—	5/16	5/16	1.03	1.40	0.188
A6TEU4-MG	—	F6TEU4	3/8	1/4	1.03	1.29	0.125
A6TEU6-MG	PP6TEU6	F6TEU6	3/8	3/8	1.03	1.64	0.250
A8TEU8-MG	PP8TEU8	—	1/2	1/2	1.21	1.64	0.380

For nonstandard plastic collet, remove -MG suffix.

RD Tube Reducer (Tube-to-Tube Stem)

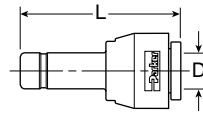

Gray Acetal EPDM Seal	White Polypropylene EPDM Seal	Natural Kynar Fluorocarbon Seal	Nom. Tube O.D.	Tube Stem O.D.	L	D Thru Hole Min.
A4RD5-MG	PP4RD5	—	1/4	5/16	1.62	0.18
A4RD6-MG	PP4RD6	—	1/4	3/8	1.62	0.18
A5RD6-MG	—	—	5/16	3/8	1.78	0.25
A5RD8-MG	—	—	5/16	1/2	1.90	0.25
A6RD8-MG	—	—	3/8	1/2	1.90	0.25

For nonstandard plastic collet, remove -MG suffix.

CAP Tube Cap

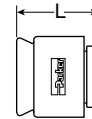

Gray Acetal EPDM Seal	White Polypropylene EPDM Seal	Natural Kynar Fluorocarbon Seal	Nom. Tube O.D.	L Overall Length
A4CAP-MG	PP4CAP	F4CAP	1/4	0.77
A6CAP-MG	PP6CAP	—	3/8	0.88

For nonstandard plastic collet, remove -MG suffix.

FE Female Elbow (Tube-to-Pipe)

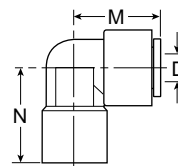

Gray Acetal EPDM Seal	White Polypropylene EPDM Seal	Natural Kynar Fluorocarbon Seal	Nom. Tube O.D.	NPTF Thread Size	M	N	D Thru Hole Min.
A4FE4-MG	—	—	1/4	1/4	0.84	1.00	0.18
A6FE4-MG	—	—	3/8	1/4	1.03	1.00	0.25
A6FE6-MG	—	—	3/8	3/8	1.03	1.00	0.25

For nonstandard plastic collet, remove -MG suffix.

F



ME Male Elbow (Tube-to-Pipe)

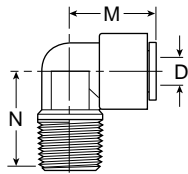

Gray Acetal EPDM Seal	White Polypropylene EPDM Seal	Natural Kynar Fluoro-carbon Seal	Nom. Tube O.D.	NPTF Thread Size	M	N	D Thru Hole Min.
A4ME2-MG	PP4ME2	F4ME2	1/4	1/8	0.84	0.94	0.175
A4ME4-MG	PP4ME4	F4ME4	1/4	1/4	0.84	0.94	0.175
A4ME6-MG	PP4ME6	F4ME6	1/4	3/8	0.84	1.04	0.175
A5ME4-MG	—	—	5/16	1/4	1.03	1.08	0.175
A5ME6-MG	—	—	5/16	3/8	1.03	1.06	0.188
A6ME4-MG	PP6ME4	F6ME4	3/8	1/4	1.03	1.08	0.250
A6ME6-MG	PP6ME6	F6ME6	3/8	3/8	1.03	1.06	0.250

For nonstandard plastic collet, remove -MG suffix.

TEB - Tube Elbow Barb Connector

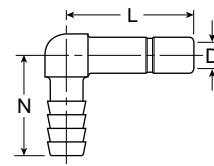

Gray Acetal	White Polypropylene	Natural Kynar	Tube Stem O.D.	Tube I.D.	M	N	D Thru Hole Min.
A4TEB4	PP4TEB4	F4TEB4	1/4	1/4	0.89	1.00	0.140
A6TEB6	PP6TEB6	F6TEB6	3/8	3/8	1.34	1.21	0.250
A8TEB8	—	—	1/2	1/2	1.30	1.30	0.390

TPL Plug

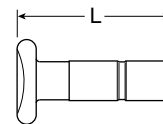

Gray Acetal	White Polypropylene	Natural Kynar	Fitting Size	L Overall Length
A4TPL	PP4TPL	F4TPL	1/4	0.88
A6TPL	PP6TPL	F6TPL	3/8	1.45
A8TPL	PP8TPL	—	1/2	1.50

ST Straight Thread (Tube-to-Male O-ring Boss)

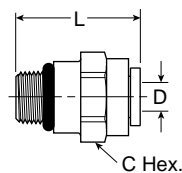

Gray Acetal EPDM Seal	White Polypropylene EPDM Seal	Natural Kynar Fluoro-carbon Seal	Nom. Tube O.D.	UNF-2B Thread Size	C Hex	L Overall Length	D Thru Hole Min.
A6ST9-MG	—	F6ST9 (+)	3/8	9/16-18	13/16	1.39	0.250

For nonstandard plastic collet, remove -MG suffix.

TCB Tube-to-Barb Connector

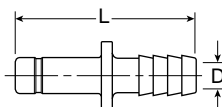

Gray Acetal	White Polypropylene	Natural Kynar	Tube Stem O.D.	Tube I.D.	L Overall Length	D Thru Hole Min.
A4TCB4	PP4TCB4	F4TCB4	1/4	1/4	1.67	0.140
A6TCB4	—	F6TCB4	3/8	1/4	1.82	0.140
A6TCB6	PP6TCB6	F6TCB6	3/8	3/8	1.98	0.250
A8TCB6	—	—	1/2	3/8	2.10	0.250
A8TCB8	—	—	1/2	1/2	2.10	0.375



TSC Cartridge Insert

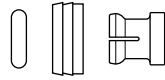

Part Number with EPDM Seal	Nom. Tube O.D.	A* Dia. ±002	B Dia. ±003	C Dia. ±003	D Dia. Min.	E Depth ±002	F Depth ±002	G Depth ±002	H* Centerline of Ports Minimum
ATSC4-MG	1/4	.528	.421	.260	.19	.230	.435	.600	.670
ATSC6-MG	3/8	.632	.545	.385	.31	.280	.455	.705	.790
ATSC8-MG	1/2	.774	.668	.510	.41	.315	.510	.810	1.250

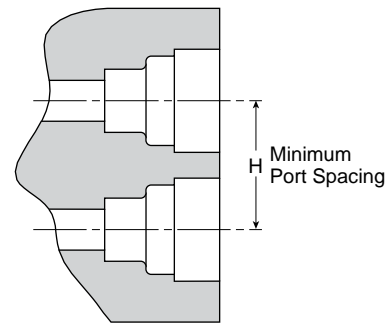
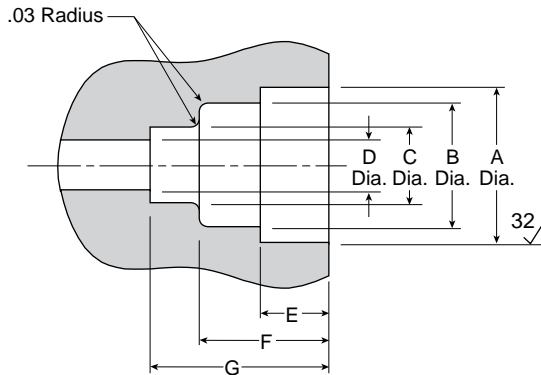

All sizes in inches

Parker TrueSeal™ Cartridge Inserts:

Allow you to machine or mold a tube connection into your equipment or components. By using cartridge inserts, you will reduce your material and assembly costs, reduce potential leak paths, and give your equipment a new, clean profile by eliminating the need for threaded connections. TSC Cartridge Inserts consist of 1 o-ring, 1 cartridge, and 1 collet.

*Cartridge inserts are rated at 300 psi in ports dimensioned as above and having Noryl as the receiving material. Other materials may have different ratings and require different port dimensions. Consult the Brass Products Division when using polypropylene, unfilled polypropylene, ABS or Nylon.

NORYL® is a registered trademark of the General Electric Co.

Assembly Instructions:

- Step 1** Machine or mold the receiving orifice as per the above dimensions.
- Step 2** Place the cartridge insert squarely onto the prepared port opening making sure that the barbs of the cartridge are going into the hole and the lettering on the face of the cartridge is visible.
- Step 3** Using a rubber mallet or press, insert the cartridge into the first gland orifice until its face is flush with the top surface of the port.
- Step 4** Insert the o-ring into the cartridge and seat it evenly into the second gland orifice.
- Step 5** Insert the collet into the cartridge opening.
- Step 6** Insert tubing.

F

Polypropylene Ball Valves

For proven leak-free performance, specify Polypropylene Ball Valves. Their corrosion-resistant, all-plastic design makes them ideal for water filtration units, coffee and beverage machines and a wide variety of other fluid applications. Polypropylene material meets all FDA and NSF-51 requirements for food contact.

Features / Benefits:

- Precision molded, all-plastic design is leak free and corrosion resistant.
- Polypropylene material offers a wider chemical acceptance range, as well as a wide temperature range.
- Bi-directional flow maximizes productivity.
- Full flow design reduces pressure drop across the valve.
- Special o-ring seal ensures a reliable leak-tight connection.
- TrueSeal™ connection reduces potential leaks.

Advantages:

- Reduce costs—Built-in TrueSeal™ connection eliminates the need for a secondary fitting.
- Save space—Low-profile design allows for easy assembly and access where space is at a premium.

Specifications:

- Temperature range: 0°F to 225°F (-18°C to 107°C).
- O-ring seal material: Nitrile.
- NSF-51 listed.
- Pressure rated to 150 PSI with a 600 PSI burst pressure. Actual working pressures will be lower at elevated temperatures.

Assembly Instructions:

1. Inspect the mating threads for debris or damage. Remove any old fluoropolymer tape or sealant on previously used threads. If threads are damaged, replace with new adapter before proceeding.
2. Apply 2 to 3 wraps of fluoropolymer tape, Parker TrueSealant™ or an NSF/FDA approved silicon sealant. Do not use Plumbers Putty or Pipe Dope. These chemically react with plastic materials and could cause a failure.
3. Align ball valve to mating thread to ensure cross threading does not occur.
4. Screw ball valve onto mating thread 3 to 5 turns. This should be sufficient to properly seal the threads.
5. Pressurize system and check for leaks.

VME Valve Male Elbow

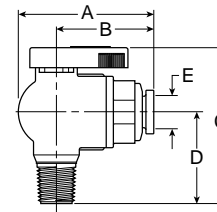

Part Number	Nom. Tube O.D.	NPTF Thread Size	A	B	C	D	E Thru Hole Min.
PP4VME2-MG (+)	1/4	1/8	1.74	1.21	2.00	1.10	0.19
PP4VME4-MG	1/4	1/4	1.74	1.21	2.18	1.28	0.19
PP4VME6-MG	1/4	3/8	1.74	1.21	2.18	1.28	0.19
PP4VME8-MG (+)	1/4	1/2	1.74	1.21	2.37	1.47	0.19
PP6VME2-MG (+)	3/8	1/8	1.85	1.32	2.00	1.10	0.25
PP6VME4-MG	3/8	1/4	1.85	1.32	2.18	1.28	0.25
PP6VME6-MG	3/8	3/8	1.85	1.32	2.18	1.28	0.25
PP6VME8-MG	3/8	1/2	1.85	1.32	2.37	1.47	0.25

VFE Valve Female Elbow

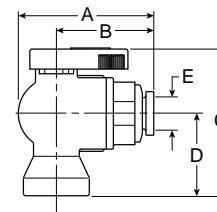

Part Number	Nom. Tube O.D.	NPTF Thread Size	A	B	C	D	E Thru Hole Min.
PP4VFE2-MG (+)	1/4	1/8	1.74	1.21	1.82	0.92	0.19
PP4VFE4-MG	1/4	1/4	1.74	1.21	2.05	1.15	0.19
PP4VFE6-MG	1/4	3/8	1.74	1.21	2.18	1.28	0.19
PP6VFE2-MG (+)	3/8	1/8	1.85	1.32	1.82	0.92	0.25
PP6VFE4-MG	3/8	1/4	1.85	1.32	2.05	1.15	0.25
PP6VFE6-MG	3/8	3/8	1.85	1.32	2.18	1.28	0.25

VUC Valve Union Connector

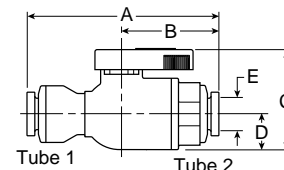

Part Number	1 Tube Size	2 Tube Size	A	B	C	D	E Thru Hole Min.
PP4VUC4-MG	1/4	1/4	2.55	1.22	1.0	0.5	0.19
PP4VUC6-MG	1/4	3/8	2.55	1.22	1.0	0.5	0.19
PP6VUC4-MG	3/8	1/4	2.57	1.30	1.4	0.5	0.19
PP6VUC6-MG	3/8	3/8	2.67	1.32	1.4	0.5	0.25

(+) Non Standard.



VEU Valve Elbow Union

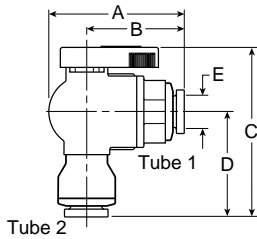

Part Number	1 Tube Size	2 Tube Size	A	B	C	D	ØE Thru Hole Min.
PP4VEU4-MG	1/4	1/4	1.75	1.22	2.33	1.42	0.19
PP4VEU6-MG	1/4	3/8	1.75	1.22	2.33	1.42	0.11
PP6VEU4-MG	3/8	1/4	1.83	1.30	2.32	1.40	0.19
PP6VEU6-MG	3/8	3/8	1.85	1.32	2.34	1.44	0.25

VFC Valve Female Connector

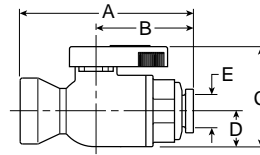

Part Number	Nom. Tube O.D.	NPTF Thread Size	A	B	C	D	ØE Thru Hole Min.
PP4VFC2-MG	1/4	1/8	2.04	1.21	1.4	0.5	0.19
PP4VFC4-MG	1/4	1/4	2.27	1.21	1.4	0.5	0.19
PP4VFC6-MG	1/4	3/8	2.40	1.21	1.4	0.5	0.19
PP6VFC2-MG	3/8	1/8	2.15	1.32	1.4	0.5	0.25
PP6VFC4-MG	3/8	1/4	2.38	1.32	1.4	0.5	0.25
PP6VFC6-MG	3/8	3/8	2.51	1.32	1.4	0.5	0.25

VMC Valve Male Connector

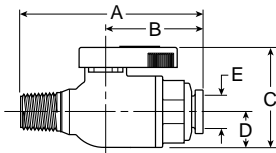

Part Number	Nom. Tube O.D.	NPTF Thread Size	A	B	C	D	ØE Thru Hole Min.
PP4VMC2-MG (+)	1/4	1/8	2.22	1.21	1.4	0.5	0.19
PP4VMC4-MG	1/4	1/4	2.40	1.21	1.4	0.5	0.19
PP4VMC6-MG	1/4	3/8	2.40	1.21	1.4	0.5	0.19
PP4VMC8-MG (+)	1/4	1/2	2.59	1.21	1.4	0.5	0.19
PP6VMC2-MG (+)	3/8	1/8	2.33	1.32	1.4	0.5	0.25
PP6VMC4-MG	3/8	1/4	2.51	1.32	1.4	0.5	0.25
PP6VMC6-MG	3/8	3/8	2.51	1.32	1.4	0.5	0.25
PP6VMC8-MG (+)	3/8	1/2	2.70	1.32	1.4	0.5	0.25

(+) Non Standard.

VTEU Valve Tube Elbow Union

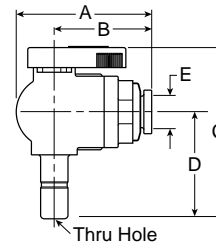

Part Number	Nom. Tube O.D.	Stem	A	B	C	D	ØE Thru Hole Min.
PP4VTEU6-MG	1/4	3/8	1.75	1.22	2.43	1.50	0.17
PP6VTEU6-MG	3/8	3/8	1.83	1.30	2.43	1.50	0.25

Cold Water Supply Valve

(Patent No. 6,213,149)

Parker's water supply valve is intended for use with Point Of Use water appliances requiring a cold water supply such as POU faucets, instant hot water faucets, reverse osmosis systems and water filtration systems. The Parker TrueSeal™ Cold Water Supply Valve is designed for temporary cold water shut-off to a POU appliance to change filters, tanks or when servicing the appliance — all while maintaining full water flow to the sink or water basin above. When the POU system is removed from service, the Parker TrueSeal™ Cold Water Supply Valve is to be removed also.

TrueSeal™ Cold Water Supply Valves are for cold water service at temperatures above freezing to 125°F ambient. Not for use in hot water service applications.

Features / Benefits:

- Fast, easy installation.
- No pierced lines or saddle hooks.
- Optimum flow to the faucet - full flow porting.
- No need to pierce the supply line.
- Connects 3/8" OD tubing directly to valve.
- 1/2" NPT connections available.
- Excellent resistance to chlorine and other chemicals.
- Integrated handle for easy on/off operation.
- Visual indicator shows open/closed position.

F



Specifications:

- NSF Standard 51 listed.
- Pressure rating: 150 PSI with a 600 PSI burst pressure.
- Design factor: 4:1
- O-ring seal material: EPDM.
- Meets the pressure integrity test of NSF-53 and NSF-58.

Applications:

- Reverse osmosis systems.
- Under sink filtration systems.
- POU faucets.
- Water supply valves are intended for cold water service at temperatures from above freezing to 125°F ambient.
- NOT for use in hot water service applications.

VTU Water Supply Valve

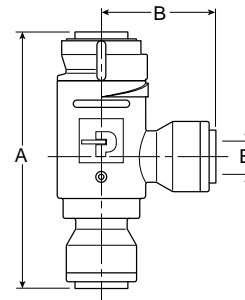

White Polypropylene	Nom. Tube O.D.	A	B	D Thru Hole Min.
PP6VTU6-MG	3/8	2.92	1.30	0.30

TrueSeal™ Cold Water Supply Valve Assembly Instructions

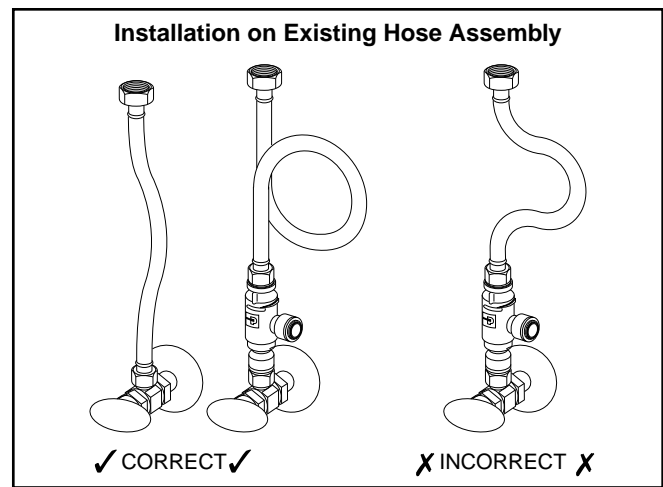
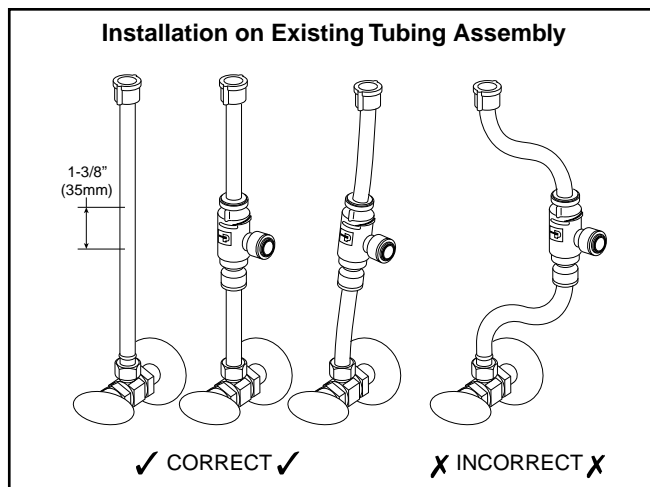

For Installation with 3/8" Plastic Tubing:

1. Shut off water at the chrome or brass valve.
2. Disconnect existing tube assembly.
3. Cut out a 1-3/8" (35 mm) section near the center of the existing tubing. Cut the tube squarely and remove any burrs.
4. Place an insertion depth mark 3/4" (19 mm) from the end of each cut on the tubing to be reused. Refer to "TrueSeal Assembly Instructions," Steps 2 and 3, for tubing assembly (reverse side).
5. Reconnect tube assembly with new valve.
6. Make sure new valve is closed before opening water valve. Open valve in Step 1 and check for leaks.
7. Insert 3/8" tubing from water appliance into side port.
8. Open new valve by turning pointer to large end of flow indicator.

For Installation with Flexible Hose:

1. Shut off water at the chrome or brass valve.
2. Disconnect one end of existing hose assembly.
3. Place the appropriate adapters on the chrome or brass valve and the hose end.
4. Tighten adapter on chrome or brass valve finger tight plus 1/2 turn. Do not over tighten.
5. Push tube portion of adapters into top and bottom of valve until bottomed out. Hose should not be kinked. A longer hose assembly might be required if a gently loop cannot be made.
6. Make sure new valve is closed before opening water valve. Pointer will be at the small end of triangle flow indicator. Open valve in Step 1 and check for leaks.
7. Insert 3/8" tubing from water appliance into side port.
8. Open new valve by turning pointer to large end of flow indicator.

Water Supply Valve Kits

Part No.	Connects to:	Kit Contains
WSV4-Kit	1/4" Compression Valve	AW6TAF7-MG, AW6TFA7-MG, PP6VTU6-MG
WSV6-Kit	3/8" Compression Valve	AW6TAF9-MG, AW6TFA9-MG, PP6VTU6-MG
WSV8-Kit	1/2" NPSM Faucet Stem	AW6TAF8-MG, AW6TFA8-MG, PP6VTU6-MG



TFA Tube Faucet Adapter (Female Thread)

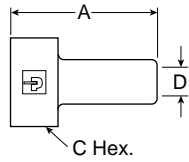

White Acetal	Tube Stem O.D.	Thread Size	A	C Hex	D Min.
AW6TFA7-MG	3/8	7/16-24	1.25	0.69	0.17
AW6TFA8-MG	3/8	1/4-14 NPSM	1.45	1.06	0.22
AW6TFA9-MG	3/8	9/16-24	1.25	0.75	0.22

TAF Tube Faucet Adapter (Male Thread)

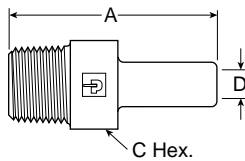

White Acetal	Tube Stem O.D.	Thread Size	A	C Hex	D Min.
AW6TAF7-MG	3/8	7/16-24	1.41	0.50	0.22
AW6TAF8-MG	3/8	1/4-14 NPSM	1.65	0.88	0.22
AW6TAF9-MG	3/8	9/16-24	1.45	0.63	0.22

SC Safety Clip (Patent No. 6,065,779)

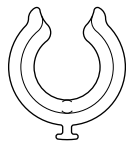

Part Number	Part Number	For Nominal Tube O.D.
SC-4	SC-4-B	1/4
SC-5	SC-5-B	5/16
SC-6	SC-6-B	3/8
SC-8	SC-8-B	1/2

Standard color is black or blue. Other colors available upon request.

TS Tube Supports

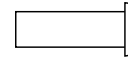

Nylon Part Number	Polypropylene Part Number
N4TS3	P4TS3
N5TS3	P5TS3
N6TS4	P6TS4
N8TS6	P8TS6

To be used with soft durometer tubing.

PTS Pipe Thread Sealant



NSF-51 listed silicone.

AQRT - Quick Release Tool

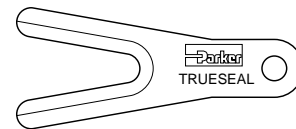

Makes disconnection of tube adapters and tubing a breeze.

F

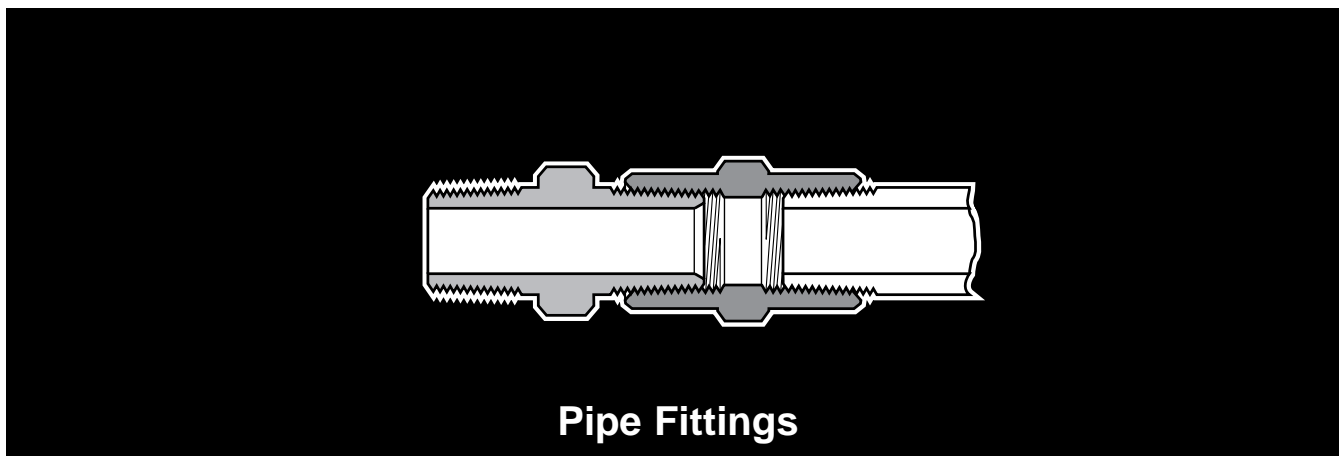

Pipe Fittings

Advantages

All pipe fitting threads are made to Dryseal standards. Connectors, unions, nuts and extruded elbows and tees are machined from CA 360 or CA 345 brass rod; forged elbows and tees are machined from CA 377 brass.

Approvals

Meets functional requirements of the SAE J530, and SAE J531.

Applications

Use with brass, copper, or iron pipe. Manufactured for low and medium pressure line connection work.

Working Pressure and Temperature Ranges

From -65°F to 250°F at 1000 PSI.

Vibration

Fair resistance to vibration and pipe movement depending upon conditions.

Nomenclature

Part numbers are constructed from symbols that identify the style and size of the fitting. The first series of numbers and letters identifies the style and type fitting. The second series of numbers describes the size.

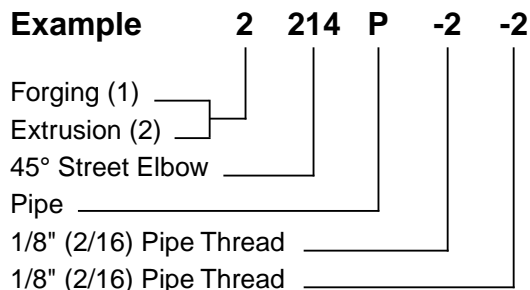

Sizes

Pipe sizes are determined by the number of sixteenths of an inch in the pipe size.

Special Fittings

Fitting configurations and/or sizes other than those shown in the catalog can be furnished. It is suggested that a print or sketch be submitted with the inquiry.



Pipe Thread Assembly Guide (Turns Method) for Dryseal Threads with Pre-applied Vibra Seal

Straight Fittings

1. Tighten external thread into the internal thread.
2. Tighten an additional 2 revolutions with a wrench up to 1/2 inch male pipe thread. Above 1/2 inch, 1-1/2 to 2-1/2 revolutions.

Finger Tight

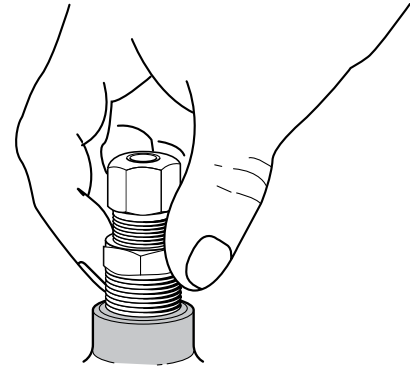

Wrench Tight

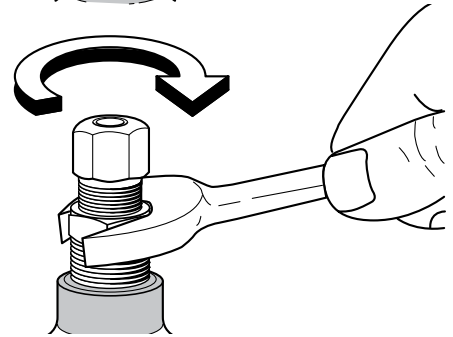

Elbow or Tee Fittings

1. Tighten external thread into the internal thread.
2. Tighten an additional 1 to 1-1/2 revolutions with a wrench.
3. Tighten fitting, Clockwise, to Align with Tubing (never counter clockwise).

Note: To minimize the possibility of a leaking threaded joint after assembling male to female pipe threads, neither end should be backed out (loosened) once the assembly has been made.

Finger Tight

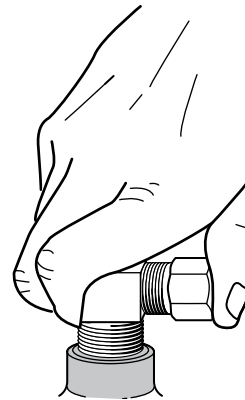

Clockwise to align

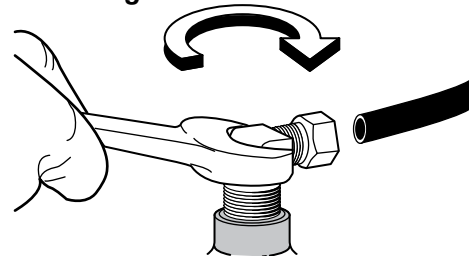

Wrench Tight

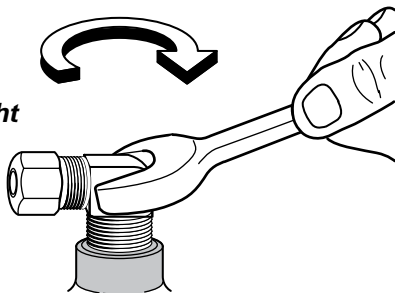

F

Part Numbers & Dimensions

207ACBH Anchor Connector

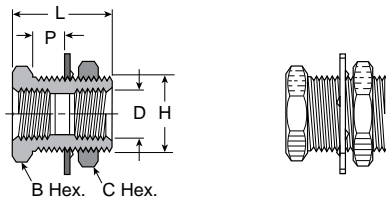

Part No.	Female		B Hex.	C Hex.	Bulk-head Hole Dia. H	L	P Max.	Flow Dia. D
	Pipe Thread	Straight Thread						
207ACBH-2	1/8	5/8-18	7/8	15/16	5/8	1.50	0.89	0.339
207ACBHS-2	1/8	5/8-18	7/8	15/16	5/8	0.96	0.35	0.339
207ACBH-4	1/4	3/4-16	1	1-1/8	3/4	1.50	0.81	0.441
207ACBHS-4	1/4	3/4-16	1	1	3/4	0.94	0.26	0.441
207ACBH-6	3/8	1-14	1-1/8	1-1/4	1	1.31	0.62	0.571
207ACBH-8	1/2	1-1/8-14	1-1/4	1-3/8	1-1/8	1.50	0.75	0.703
207ACBH-12	3/4	1-5-16-14	1-1/2	1-1/2	1-5/16	1.50	0.65	0.906
207ACBH-16*	3/4	1-5-8-14	2	2	1-5/8	1.68	1.00	1.140

* Lock Washer Not Available

209P Bushing

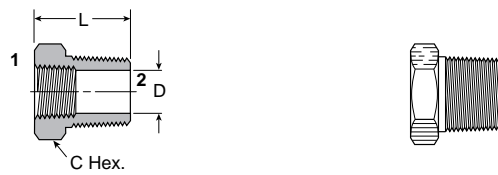

Part No.	1 Pipe Thread	2 Pipe Thread	C Hex.	L	Flow Dia. D
209P-4-2	1/8	1/4	9/16	0.75	0.339
209P-6-2	1/8	3/8	11/16	0.75	0.339
209P-6-4	1/4	3/8	11/16	0.75	0.441
209P-8-2	1/8	1/2	7/8	1.00	0.339
209P-8-4	1/4	1/2	7/8	1.00	0.441
209P-8-6	3/8	1/2	7/8	1.00	0.571
209P-12-2	1/8	3/4	1-1/8	1.00	0.339
209P-12-4	1/4	3/4	1-1/8	1.00	0.441
209P-12-6	3/8	3/4	1-1/8	1.00	0.571
209P-12-8	1/2	3/4	1-1/8	1.00	0.703
209P-16-8	1/2	1	1-3/8	1.31	0.703
209P-16-12	3/4	1	1-3/8	1.31	0.906

207P Coupling

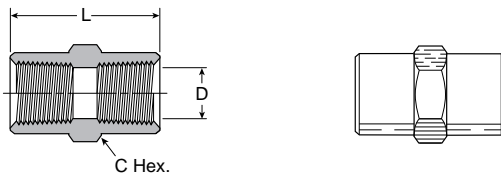

Part No.	Pipe Thread	C Hex.	L	Flow Dia. D
207P-2	1/8	9/16	0.75	0.339
207P-4	1/4	3/4	1.12	0.441
207P-6	3/8	7/8	1.12	0.571
207P-8	1/2	1-1/16	1.50	0.703
207P-12	3/4	1-3/8	1.53	0.906

210P Lock Nut



Part No.	Pipe Thread	C Hex.	L
210P-2	1/8 NPSL	11/16	0.19
210P-4	1/4 NPSL	7/8	0.25
210P-6	3/8 NPSL	1	0.25
210P-8	1/2 NPSL	1-1/8	0.25

208P Reducer Coupling

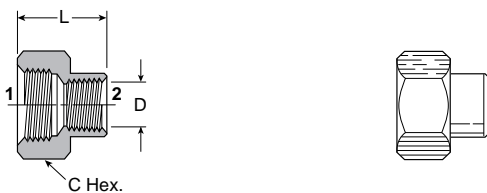

Part No.	1 Pipe Thread	2 Pipe Thread	C Hex.	L	Flow Dia. D
208P-4-2	1/4	1/8	3/4	0.97	0.339
208P-6-4	3/8	1/4	7/8	1.16	0.441
208P-8-4	1/2	1/4	1-1/16	1.28	0.441
208P-8-6	1/2	3/8	1-1/16	1.38	0.571
208P-12-6	3/4	3/8	1-3/8	1.32	0.571
208P-12-8	3/4	1/2	1-3/8	1.50	0.703

211P Square-head Plug



Part No.	Pipe Thread	C Square	L	M
211P-2	1/8	9/32	.59	.25
211P-4	1/4	3/8	.80	.29
211P-6	3/8	15/32	.80	.32
211P-8	1/2	9/16	1.07	.39
211P-12	3/4	5/8	1.14	.45



212P Union

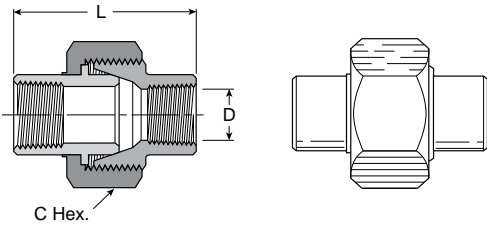

Part No.	Pipe Thread	C Hex.	L	Flow Dia. D
212P-4	1/4	1-3/16	1.54	0.441
212P-6	3/8	1-1/4	1.76	0.571

213P Cap



Part No.	Pipe Thread	C Hex.	L
213P-2	1/8	9/16	0.50
213P-4	1/4	11/16	0.63
213P-6	3/8	13/16	0.63
213P-8	1/2	1-1/16	0.87
213P-12	3/4	1-1/4	0.89

215PNL Long Nipple

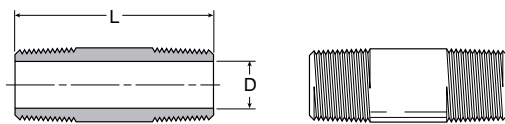

Part No.	Pipe Thread	L	Flow Dia. D
215PNL-2-15	1/8	1-1/2	0.250
215PNL-4-15	1/4	1-1/2	0.375
215PNL-6-15	3/8	1-1/2	0.500
215PNL-8-15	1/2	1-1/2	0.625
215PNL-2-20	1/8	2	0.250
215PNL-4-20	1/4	2	0.375
215PNL-6-20	3/8	2	0.500
215PNL-8-20	1/2	2	0.625
215PNL-2-25	1/8	2-1/2	0.250
215PNL-4-25	1/4	2-1/2	0.375
215PNL-6-25	3/8	2-1/2	0.500
215PNL-8-25	1/2	2-1/2	0.625
215PNL-2-30	1/8	3	0.250
215PNL-4-30	1/4	3	0.375
215PNL-6-30	3/8	3	0.500
215PNL-8-30	1/2	3	0.625
215PNL-2-35	1/8	3-1/2	0.250
215PNL-4-35	1/4	3-1/2	0.375
215PNL-6-35	3/8	3-1/2	0.500
215PNL-8-35	1/2	3-1/2	0.625

215PN Close Nipple



Part No.	Pipe Thread	L	Flow Dia. D
215PN-2	1/8	0.75	0.281
215PN-4	1/4	0.88	0.375
215PN-6	3/8	1.00	0.500
215PN-8	1/2	1.13	0.625
215PN-12	3/4	1.31	0.750

216P Hex Nipple

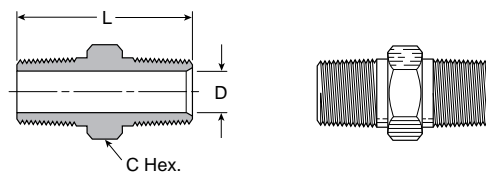

Part No.	Pipe Thread	C Hex.	L	Flow Dia. D
216P-2	1/8	7/16	0.97	0.220
216P-4	1/4	9/16	1.38	0.314
216P-6	3/8	11/16	1.41	0.440
216P-8	1/2	7/8	1.81	0.564
216P-12	3/4	1-1/16	1.81	0.752

216P Reducers

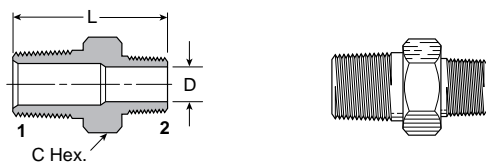

Part No.	1 Pipe Thread	2 Pipe Thread	C Hex.	L	Flow Dia. D
216P-4-2	1/4	1/8	9/16	1.19	0.220
216P-6-2	3/8	1/8	11/16	1.22	0.220
216P-6-4	3/8	1/4	11/16	1.41	0.314
216P-8-4	1/2	1/4	7/8	1.62	0.314
216P-8-6	1/2	3/8	7/8	1.62	0.440
216P-12-8	3/4	1/2	1-1/16	1.80	0.564

F



218P Hex-head Plug



Part No.	Pipe Thread	C Hex.	L
218P-2	1/8	7/16	0.560
218P-4	1/4	9/16	0.747
218P-6	3/8	11/16	0.780
218P-8	1/2	7/8	0.970
218P-12	3/4	1-1/16	1.054

219P Countersunk Hex-head Plug



Part No.	Pipe Thread	C Hex.	L
219P-2	1/8	3/16	0.30
219P-4	1/4	1/4	0.46
219P-6	3/8	5/16	0.46
219P-8	1/2	3/8	0.61
219P-12	3/4	9/16	0.62

220P Slotted Head Plug



Part No.	Pipe Thread	L
220P-2	1/8	0.31
220P-4	1/4	0.42
220P-6	3/8	0.43

222P Adapter

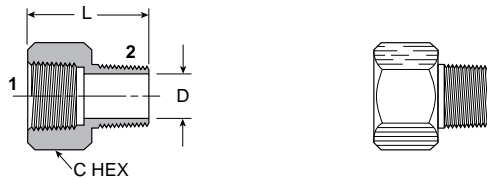

Part No.	1 Pipe Thread	2 Pipe Thread	C Hex.	L	Flow Dia. D
222P-2-2	1/8	1/8	9/16	0.88	.220
222P-4-2	1/4	1/8	3/4	1.06	.220
222P-4-4	1/4	1/4	3/4	1.25	.314
222P-6-2	3/8	1/8	7/8	1.10	.220
222P-6-4	3/8	1/4	7/8	1.25	.314
222P-6-6	3/8	3/8	7/8	1.25	.440
222P-8-4	1/2	1/4	1	1.47	.314
222P-8-6	1/2	3/8	1-1/16	1.47	.440
222P-8-8	1/2	1/2	1-1/16	1.66	.564
222P-12-6	3/4	3/8	1-3/8	1.50	.440
222P-12-8	3/4	1/2	1-3/8	1.69	.564
222P-12-12	3/4	3/4	1-3/8	1.69	.752

1200P-2200P Union Elbow 90°.

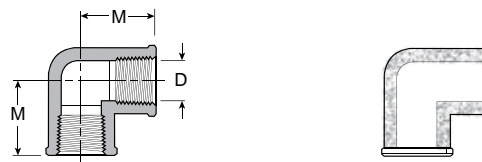

1200P

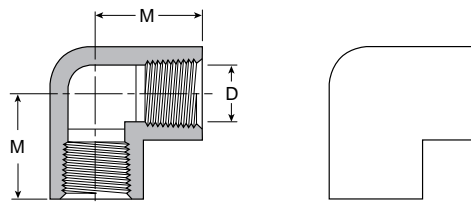

2200P

Part No.	Pipe Thread	M	Dia. D
1200P-2-2	1/8	.56	0.329
2200P-2-2	1/8	.55	0.339
1200P-4-4	1/4	.81	0.441
2200P-4-4	1/4	.78	0.441
1200P-6-6	3/8	.84	0.571
2200P-6-6	3/8	.84	0.571
2200P-8-8	1/2	1.07	0.703



1201P- 2201P Female Elbow 45°

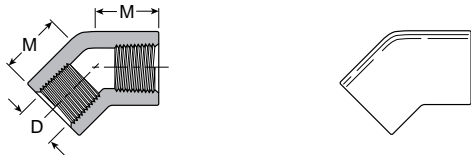

Part No.	Pipe Thread	M	Flow Dia. D
2201P-2-2	1/8	0.43	0.339
1201P-8-8	1/2	0.89	0.703

1202P-2202P Street Elbow 90°

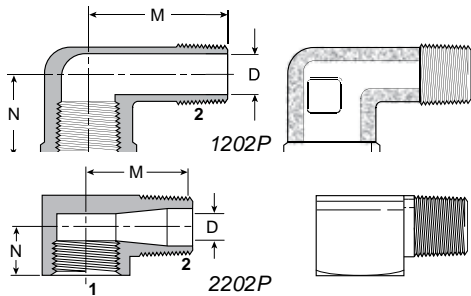

Part No.	1 Pipe Thread	2 Pipe Thread	M	N	Flow Dia. D
1202P-2-2	1/8	1/8	0.81	0.56	0.22
2202P-2-2	1/8	1/8	0.62	0.48	0.22
2202PA-2-2*	1/8	1/8	0.66	0.48	0.22
2202P-4-2	1/4	1/8	0.72	0.45	0.23
1202P-4-4	1/4	1/4	1.08	0.69	0.31
2202P-4-4	1/4	1/4	0.91	0.45	0.34
2202PA-4-4*	1/4	1/4	0.91	0.72	0.31
2202P-4-6	1/4	3/8	0.97	0.78	0.43
1202P-6-4	3/8	1/4	1.25	0.78	0.31
1202P-6-6	3/8	3/8	1.25	0.78	0.42
2202P-6-6	3/8	3/8	0.98	0.54	0.41
2202PA-6-6*	3/8	3/8	0.97	0.78	0.43
1202P-6-8	3/8	1/2	1.53	1.01	0.56
1202P-8-6	1/2	3/8	1.25	0.97	0.42
2202P-8-8	1/2	1/2	1.25	1.03	0.56
2202P-12-8	3/4	1/2	1.39	1.10	0.56
2202P-12-12	3/4	3/4	1.39	1.10	0.75

* Meets SAE dimensions.

1203P-2203P Union Tee

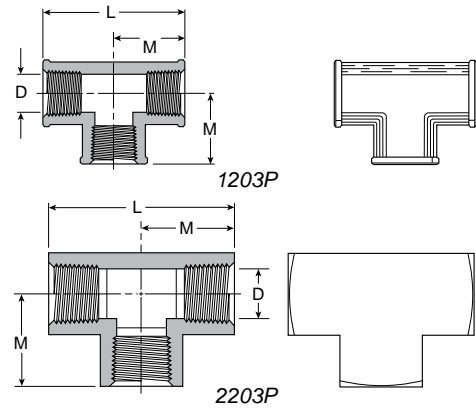

Part No.	Pipe Thread	L	M	Flow Dia. D
1203P-2	1/8	1.12	0.56	0.339
2203P-2	1/8	1.06	0.53	0.339
1203P-4	1/4	1.38	0.69	0.441
2203P-4	1/4	1.52	0.76	0.441
2203P-6	3/8	1.68	0.84	0.571
1203P-8	1/2	2.14	1.07	0.703
2203P-8	1/2	2.14	1.07	0.703
2203P-12	3/4	2.28	1.14	0.906

1204P Male Elbow

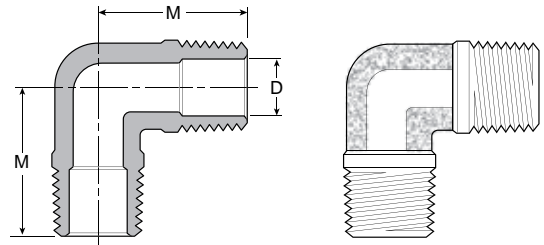

Part No.	Pipe Thread	M	Flow Dia. D
1204P-2	1/8	0.71	0.220
1204P-4	1/4	1.09	0.312
1204P-6	3/8	1.09	0.408
1204P-8	1/2	1.41	0.502

2200PDE Drop-ear Elbow 90°

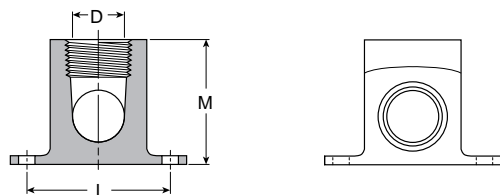

Part No.	Pipe Thread	L	M	Dia. D
2200PDE-2	1/8	1.38	1.00	0.339

F

2205P Cross

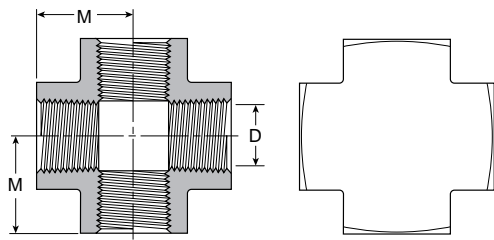

Part No.	Pipe Thread	M	Flow Dia. D
2205P-2	1/8	0.53	0.339
2205P-4	1/4	0.75	0.441
2205P-6	3/8	0.81	0.571
2205P-8	1/2	1.07	0.703
2205P-12	3/4	1.14	0.906

2225P Street Tee

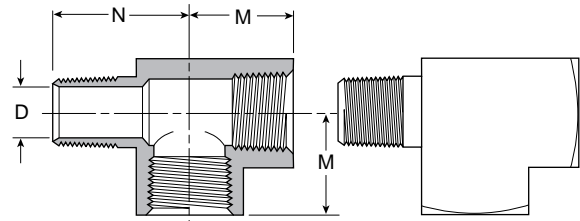

Part No.	Pipe Thread	M	N	Flow Dia. D
2225P-2	1/8	.53	.66	.220
2225P-4	1/4	.76	.91	.314
2225P-6	3/8	.84	.98	.440
2225P-8	1/2	1.07	1.26	.564
2225P-12	3/4	1.14	1.38	.752

2214P 45° Street Elbow

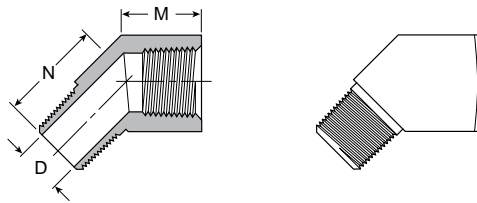

Part No.	Pipe Thread	M	N	Flow Dia. D
2214P-2-2	1/8	.38	.50	.220
2214P-4-4	1/4	.54	.70	.314
2214P-6-6	3/8	.54	.78	.440
2214P-8-8	1/2	.73	1.00	.564

2224P Male Branch Tee

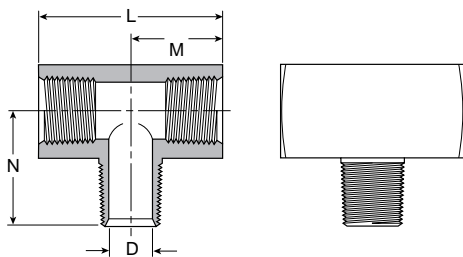

Part No.	Pipe Thread	L	M	N	Flow Dia. D
2224P-2	1/8	1.06	.53	.66	.220
2224P-4	1/4	1.52	.76	.91	.314
2224P-6	3/8	1.68	.84	.97	.440
2224P-8	1/2	2.18	1.09	1.25	.564
2224P-12	3/4	2.32	1.16	1.38	.752



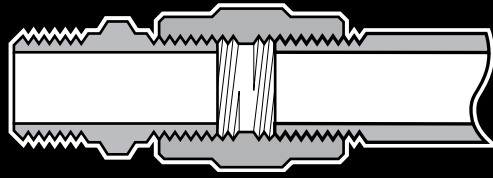

Parker Brass Metric Adapters

Advantages

To simplify the installation of pneumatic systems, Parker supplies a comprehensive range of adapters for NPT, BSPP, and BSPT pipe threads. Pipe nipples, pipe connectors, reducing connectors, pipe thread reducers, bulkhead female unions, elbows, tees, crosses and hex head plugs.

Parker brass adapters are produced from forgings and extrusions to meet exacting requirements. The hot forging process increases the density of the material, refines the grain structure and improves material strength.

Applications

Use with brass, copper, or iron pipe. Manufactured for low- and medium-pressure line connection work.

Working Pressure and Temperature Ranges

From -65° to +250° at 1000 psi.

Vibration

Fair resistance to vibration and pipe movement depending upon conditions.

F

CD43 90° Elbow Male-Female (BSPT-BSPP)

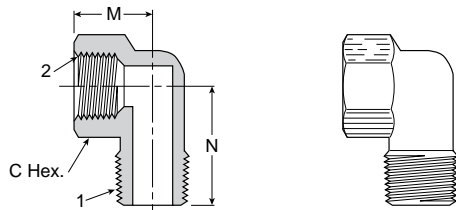

Part No.	BSPT 1	BSPP 2	C Hex. (mm)	M (mm)	N (mm)
1/8CD43B	1/8	1/8	14	14	20
1/4CD43B	1/4	1/4	17	18	25
3/8CD43B	3/8	3/8	22	19	29
1/2CD43B	1/2	1/2	27	24	37

F3HG Adapter NPTF Male (BSPT)

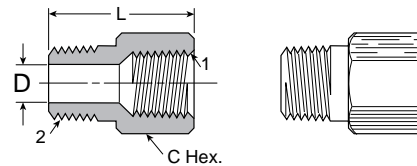

Part No.	NPTF 1	BSPT 2	C Hex. (mm)	L (mm)	Flow Dia. D
1/8F3HG-B	1/8	1/8	9/16	0.93	0.22
1/4F3HG-B	1/4	1/4	3/4	1.35	0.31
3/8F3HG-B	3/8	3/8	7/8	1.35	0.44
1/2F3HG-B	1/2	1/2	1-1/16	1.76	0.56

DD44 90° Elbow (BSPP)

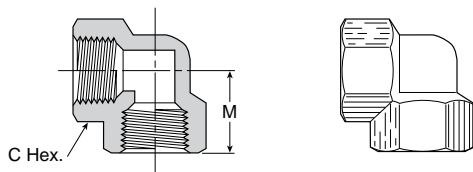

Part No.	BSPP	C Hex. (mm)	M (mm)
1/8DD44B	1/8	14	15
1/4DD44B	1/4	17	18
3/8DD44B	3/8	22	22
1/2DD44B	1/2	27	29

FF33 Pipe Nipple (BSPT)

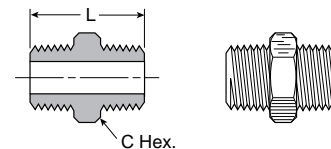

Part No.	BSPP	C Hex. (mm)	L (mm)
1/8FF33B	1/8	10	19
1/4FF33B	1/4	14	27
3/8FF33B	3/8	17	28
1/2FF33B	1/2	22	36
3/4FF33B	3/4	27	40
1FF33B	1	36	46

F3HF Hex Nipple NPTF (BSPT)

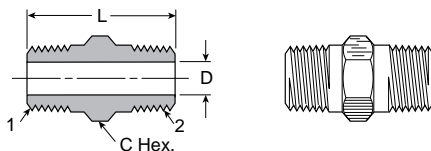

Part No.	NPTF 1	BSPT 2	C Hex. (mm)	L (mm)	Flow Dia. D
1/8F3HF-B	1/8	1/8	7/16	1.07	0.22
1/4F3HF-B	1/4	1/4	9/16	1.58	0.31
3/8F3HF-B	3/8	3/8	11/16	1.16	0.44
1/2F3HF-B	1/2	1/2	7/8	2.01	0.56

FF33 Unequal Pipe Nipple (BSPT)

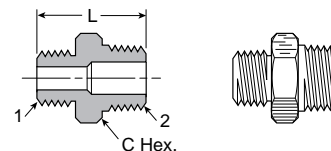

Part No.	BSPT 1	BSPT 2	C Hex. (mm)	L (mm)
1/8x1/4FF33B	1/8	1/4	14	23
1/8x3/8FF33B	1/8	3/8	17	24
1/8x1/2FF33B	1/8	1/2	22	28
1/4x3/8FF33B	1/4	3/8	17	28
1/4x1/2FF33B	1/4	1/2	22	31
3/8x1/2FF33B	3/8	1/2	22	32
3/8x3/4FF33B	3/8	3/4	27	35
1/2x3/4FF33B	1/2	3/4	27	38
3/4x1FF33B	3/4	1	36	43



FF44 Pipe Nipple (BSPP)

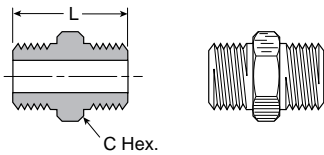

Part No.	BSPP	C Hex. (mm)	L (mm)
1/8FF44B	1/8	14	19
1/4FF44B	1/4	17	22
3/8FF44B	3/8	22	24
1/2FF44B	1/2	27	31

FHG4 Adapter Male (NPTF-BSPP)

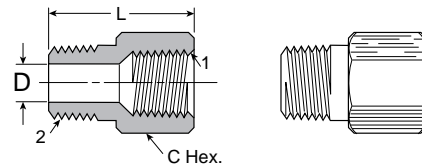

Part No.	BSPP 1	NPTF 2	C Hex.	L	Flow Dia. D
1/8FHG4-B	1/8	1/8	0.562	0.870	0.22
1/4FHG4-B	1/4	1/4	0.750	1.125	0.31
3/8FHG4-B	3/8	3/8	0.875	1.125	0.44
1/2FHG4-B	1/2	1/2	1.062	1.660	0.60

**M16M22F8UHA8UB
Metric Straight Thread Union**

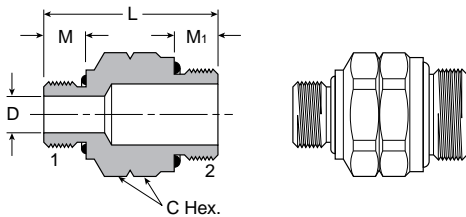

Part No.	Metric Thd. 1	Metric Thd. 2	C Hex. (mm)	L (mm)	M (mm)	M1 (mm)	Flow Dia. D (mm)
M16M22F8UHA8UB	M16X1.5	M22X1.5	43	27	10	12.5	9

Note: Fluorocarbon o-ring is standard

222P-X-MIX Pipe to Metric Adapter

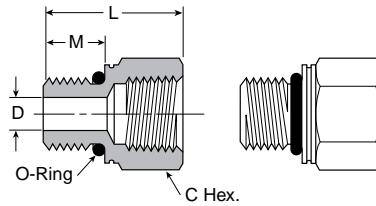

Part No.	NPTF	Metric Thd. 1	C Hex.	L	M	Flow Dia. D
222P-2-MI10	1/8-27	M10 x 1.0	9/16	0.75	0.34	0.18
222P-2-MI14	1/8-27	M14 x 1.5	3/4	0.91	0.43	0.30
222P-4-MI12	1/4-18	M12 x 1.5	11/16	1.09	0.43	0.24
222P-6-MI16	3/8-18	M16 x 1.5	7/8	1.10	0.45	0.35
222P-6-MI22	3/8-18	M22 x 1.5	1-1/16	1.05	0.37	0.47
222P-8-MI27	1/2-14	M27 x 2.0	1-1/4	1.32	0.63	0.60

Note: Fluorocarbon o-ring is standard

FG43 Reducing Connector Female-Male (BSPP-BSPT)

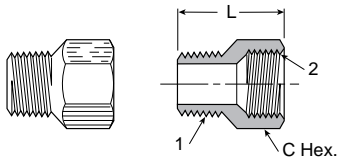

Part No.	BSPT 1	BSPP 2	C Hex. (mm)	L (mm)
1/4x1/8FG43B	1/8	1/4	17	23
3/8x1/8FG43B	1/8	3/8	22	25
3/8x1/4FG43B	1/4	3/8	22	28
1/2x1/8FG43B	1/8	1/2	27	29
1/2x1/4FG43B	1/4	1/2	27	32
1/2x3/8FG43B	3/8	1/2	27	31
3/4x1/2FG43B	1/2	3/4	32	39
1x3/4FG43B	3/4	1	41	38

GG44 Pipe Connector (BSPP)

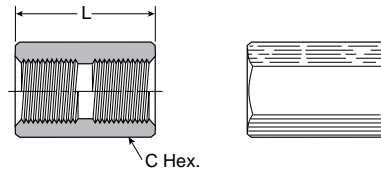

Part No.	BSPP	C Hex. (mm)	L (mm)
1/8GG44B	1/8	14	16
1/4GG44B	1/4	17	20
3/8GG44B	3/8	22	24
1/2GG44B	1/2	27	28
3/4GG44B	3/4	32	32
1GG44B	1	41	36

F

GG44 Unequal Pipe Connector (BSPP)

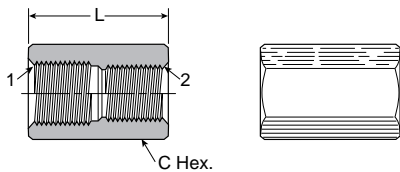

Part No.	BSPP 1	BSPP 2	C Hex. (mm)	L (mm)
1/8x1/4GG44B	1/8	1/4	17	18
1/8x3/8GG44B	1/8	3/8	22	20
1/8x1/2GG44B	1/8	1/2	27	22
1/4x3/8GG44B	1/4	3/8	22	22
1/4x1/2GG44B	1/4	1/2	27	24
3/8x1/2GG44B	3/8	1/2	17	26

HHP3 Hollow Hex Head Plug (BSPT)



Part No.	BSPP	C Hex. (mm)	L (mm)
1/8HHP3B	1/8	5	8
1/4HHP3B	1/4	6	10
3/8HHP3B	3/8	8	11
1/2HHP3B	1/2	10	13

HP3 Hex Plug (BSPT)



Part No.	BSPP	C Hex. (mm)	L (mm)
1/8HP3B	1/8	10	12
1/4HP3B	1/4	14	16
3/8HP3B	3/8	17	17
1/2HP3B	1/2	22	21
3/4HP3B	3/4	27	24
1HP3B	1	36	27

KMMOO4 Pipe Cross (BSPP)

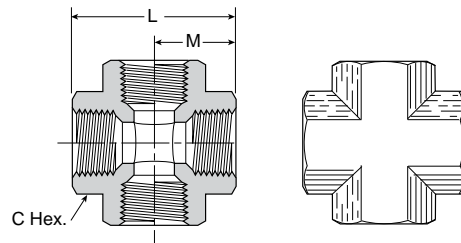

Part No.	BSPP	C Hex. (mm)	L (mm)	M (mm)
1/8KMMOO4B	1/8	14	29	14.5
1/4KMMOO4B	1/4	17	36	18.0
3/8KMMOO4B	3/8	22	44	22.0
1/2KMMOO4B	1/2	27	58	29.0

MMO444 Pipe Tee (BSPP)

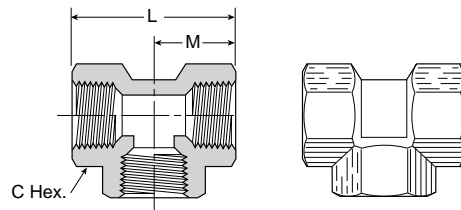

Part No.	BSPP	C Hex. (mm)	L (mm)	M (mm)
1/8MMO444B	1/8	14	29	14.5
1/4MMO444B	1/4	17	36	18.0
3/8MMO444B	3/8	22	44	22.0
1/2MMO444B	1/2	27	58	29.0
3/4MMO444B	3/4	32	62	31.0
1MMO444B	1	40	85	42.5

MMS443 Branch Tee (Female BSPP - Male BSPT - Female BSPP)

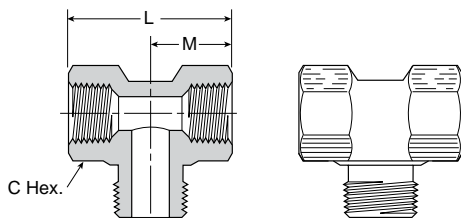

Part No.	BSPP 1	BSPT 2	L	M	N
1/8MMS443B	1/8	1/8	29	14.5	17
1/4MMS443B	1/4	1/4	36	18.0	22
3/8MMS443B	3/8	3/8	48	24.0	25
1/2MMS443B	1/2	1/2	62	31.0	32



MRO434 Run Tee

(Female BSPP - Female BSPP - Male BSPT)

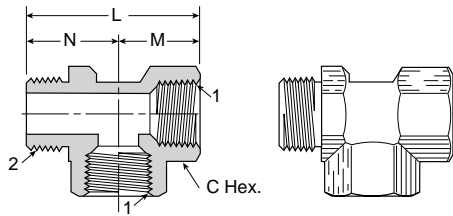

Part No.	C		L (mm)	M (mm)	N (mm)
	BSPP 1	BSPT 2			
1/8MRO434B	1/8	1/8	14	32	15
1/4MRO434B	1/4	1/4	17	40	18
3/8MRO434B	3/8	3/8	24	49	24
1/2MRO434B	1/2	1/2	30	63	31

WGG44 Bulkhead Female Union (BSPP)

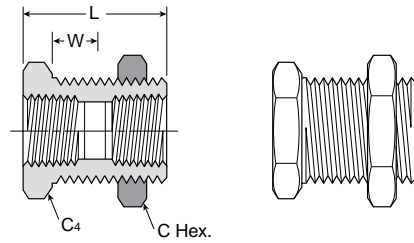

Part No.	C		C ₄ (mm)	L (mm)	W (mm)
	BSPP	Straight Thread			
1/8WGG44B	1/8	M16x1.5	19	22	12
1/4WGG44B	1/4	M20x1.5	24	24	12
3/8WGG44B	3/8	M23x1.5	27	24	12
1/2WGG44B	1/2	M27x1.5	32	28	14
3/4WGG44B	3/4	M34x1.5	41	31	13
1WGG44B	1	M45x2	55	36	12

PTR34 Pipe Thread Reducer

(Male BSPT - Female BSPP)

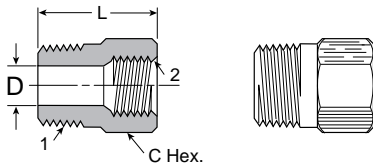

Part No.	C		L (mm)
	BSPT 1	BSPP 2	
1/4x1/8PTR34B	1/4	1/8	14
3/8x1/8PTR34B	3/8	1/8	17
3/8x1/4PTR34B	3/8	1/4	17
1/2x1/8PTR34B	1/2	1/8	22
1/2x1/4PTR34B	1/2	1/4	22
1/2x3/8PTR34B	1/2	3/8	22
3/4x3/8PTR34B	3/4	3/8	27
3/4x1/2PTR34B	3/4	1/2	27
1x1/2PTR34B	1	1/2	36
1x3/4PTR34B	1	3/4	36

Copper Rings for BSPP

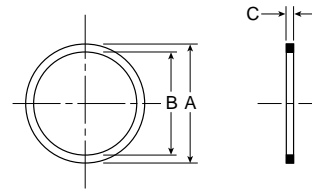

Part No.	BSPP	A (mm)	B (mm)	C (mm)
112-5-10	1/8	16.0	9.9	1.5
112-8-13	1/4	19.0	13.5	1.5
112-12-17	3/8	24.0	16.9	1.5
112-15-21	1/2	27.0	21.2	2.0

F

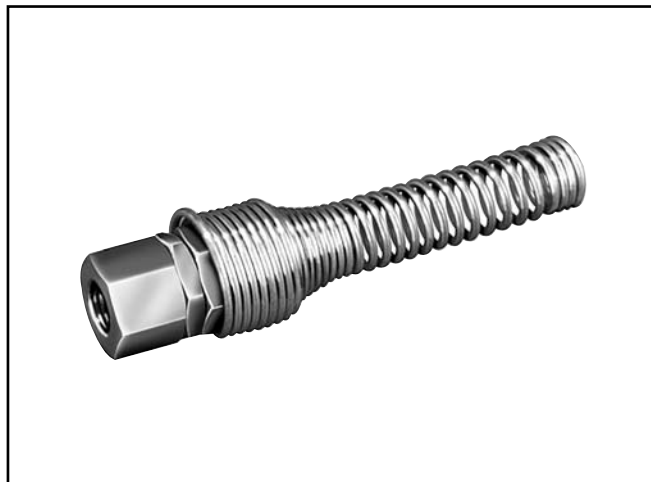
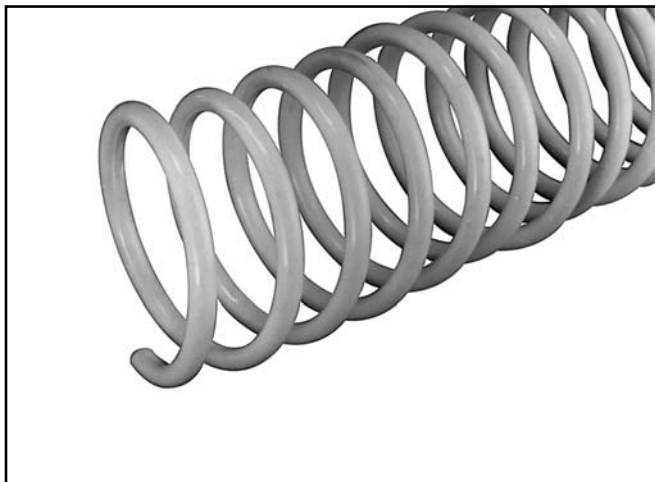

Advantages

FS self retracting air hose is manufactured from an extremely tough, abrasion resistant nylon. FS hose has excellent “memory” characteristics over a wide temperature range for long service life in the most rugged applications. The SAFETY YELLOW color of FS hose is highly desirable due to U.S. Government “OSHA” directives. Service temperature range from -40°F to 200°F.

Advantages

Fittings for FS hose are heavy duty brass construction with built in insert-supports. Fitting bodies are SAE standard sizes. Hose entry length into the fittings is the longest in the industry due to SAE body design and size standardization, assuring a strong grip on the hose.

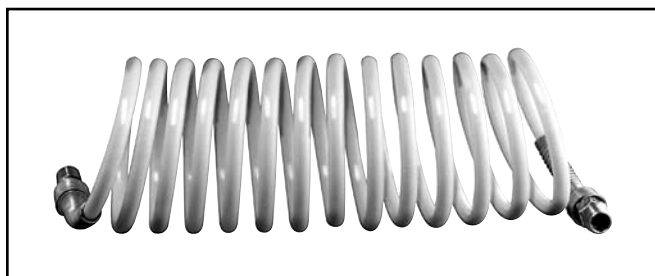

Popular Stock Assemblies

Assembly Part No.	FS Hose I.D.	Total Length of Hose	Usable Length	Fitting End #1	Fitting End #2 (Live Swivel)
A0312-MC4-ML4	3/16"	12'	9'	1/4" MPT	1/4" MPT
A0325-MC4-ML4	3/16"	25'	18'	1/4" MPT	1/4" MPT
A0350-MC4-ML4	3/16"	50'	38'	1/4" MPT	1/4" MPT
A0412-MC4-ML4	1/4"	12'	9'	1/4" MPT	1/4" MPT
A0425-MC4-ML4	1/4"	25'	18'	1/4" MPT	1/4" MPT
A0450-MC4-ML4	1/4"	50'	38'	1/4" MPT	1/4" MPT
A0612-MC6-ML6	3/8"	12'	9'	3/8" MPT	3/8" MPT
A0625-MC6-ML6	3/8"	25'	18'	3/8" MPT	3/8" MPT
A0650-MC6-ML6	3/8"	50'	38'	3/8" MPT	3/8" MPT
A0812-MC8-ML8	1/2"	12'	9'	1/2" MPT	1/2" MPT
A0825-MC8-ML8	1/2"	25'	18'	1/2" MPT	1/2" MPT
A0850-MC8-ML8	1/2"	50'	38'	1/2" MPT	1/2" MPT

Bulk hose FS

Part No.	Hose I.D.	Average Wall Thick.	Hose Length	Master Carton Quantity	Coil Min. I.D.	Coil Max. O.D.	Maximum Working Pressure psi*
FS-03-100	3/16"	.023	100'	600'	2.0	2.5	170
FS-04-100	1/4"	.030	100'	600'	3.0	3.7	170
FS-06-100	3/8"	.045	100'	400'	4.5	5.5	170
FS-08-100	1/2"	.062	100'	400'	6.5	7.8	170
FS-12-100	3/4"	.075	100'	100'	12.0	14.0	170

*Maximum working pressure listed at 75°F or lower and based on safety factor of 4:1 over burst.



Measuring Bulk Hose

Measuring FS hose is quick and easy and may be accomplished by either of two accurate methods:

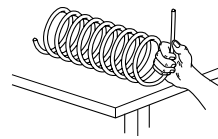

Position bulk length coils on work table extending away from you, cut-end up in 12:00 o'clock position.

1. Counting

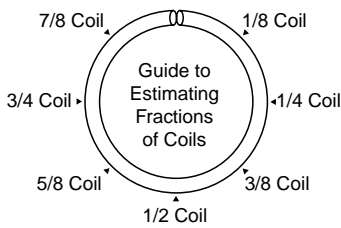
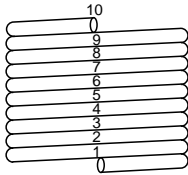
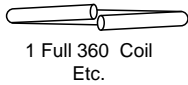

Total Length of hose		Number of Coils Needed to Obtain Required Net Extended Length +38%				
Feet	Inches	3/16" I.D.	1/4" I.D.	3/8" I.D.	1/2" I.D.	3/4" I.D.
3	36	5-1/8 coils	3-1/2 coils	2-1/4 coils	1-5/8 coils	7/8 coils
5	60	8-1/2 coils	5-3/4 coils	3-7/8 coils	2-5/8 coils	1-1/2 coils
7	84	12 coils	8-1/8 coils	5-3/8 coils	3-3/4 coils	2-1/8 coils
10	120	17-1/8 coils	11-1/2 coils	7-3/4 coils	5-3/8 coils	3 coils
12	144	20-1/2 coils	13-7/8 coils	9-1/4 coils	6-1/2 coils	3-1/2 coils
15	180	25-3/4 coils	17-3/8 coils	11-1/2 coils	8 coils	4-1/2 coils
16	192	27-3/8 coils	18-1/2 coils	12-3/8 coils	8-5/8 coils	4-3/4 coils
17	204	29-1/8 coils	19-5/8 coils	13-1/8 coils	9-1/8 coils	5 coils
18	216	30-7/8 coils	20-3/4 coils	13-7/8 coils	9-5/8 coils	5-3/8 coils
19	228	32-1/2 coils	22 coils	14-5/8 coils	10-1/4 coils	5-5/8 coils
20	240	34-1/4 coils	23-1/8 coils	15-3/8 coils	10-3/4 coils	6 coils
25	300	42-7/8 coils	28-7/8 coils	19-1/4 coils	13-3/8 coils	7-1/2 coils
30	360	51-3/8 coils	34-5/8 coils	23-1/8 coils	16-1/8 coils	8-7/8 coils
33	396	56-1/2 coils	38-1/8 coils	25-3/8 coils	17-3/4 coils	9-3/4 coils
50	600	85-5/8 coils	57-3/4 coils	38-1/2 coils	26-7/8 coils	14-7/8 coils

2. Division Into Even Numbers of Lengths

Bulk retracted lengths of FS hose are always exactly 100 feet long when shipped from the factory. Some diameter expansion of the coils may have occurred in shipment due to temperature and storage conditions. This may appear to have shortened a given 100' retracted length slightly in relation to other 100' retracted lengths in the same master carton. The shorter appearance should not be mistaken for an

actual shortage in extended length. A bulk retracted length may be easily divided into smaller lengths by first measuring the tightly retracted length in inches, and dividing by 4 to determine the cut off length for 25', by 3 for 33 feet, by 8 for 12-1/2 feet, etc. Pieces should be tagged with their proper length before returning to storage.

Assembly Instructions

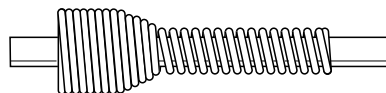

1. Cut end of hose as square as possible. Disassemble fitting and install spring guard on hose with larger coiled end of spring toward end of hose.

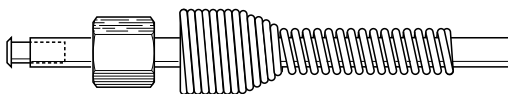

2. Install nut on hose, insert brass tube support.

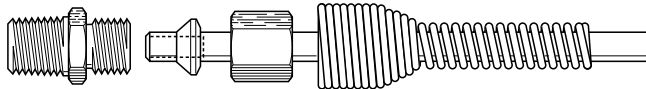

3. Slip plastic ferrule over hose, with thin, tapered end toward end of hose.

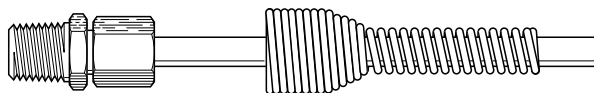

4. Push hose into fitting body, until hose bottoms in fitting and slide nut and ferrule assembly up to engage thread and tighten hand-tight. Add 1-1/2 to 2 turns with a wrench.

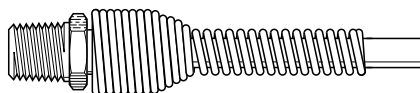

5. Insert assembled fitting into spring guard. Assembly is now complete.

F



MC Male Connector

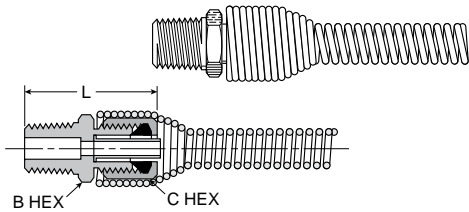

Part No.	Hose I.D.	End Type	End Size	B Hex	C Hex	L	Box Qty.
MC-03-2	3/16	MPT-Straight	1/8 MPT	9/16	1/2	1-3/8	20
MC-03-4	3/16	MPT-Straight	1/4 MPT	9/16	1/2	1-9/16	20
MC-04-2	1/4	MPT-Straight	1/8 MPT	9/16	9/16	1-3/8	20
MC-04-4	1/4	MPT-Straight	1/4 MPT	9/16	9/16	1-9/16	20
MC-06-6	3/8	MPT-Straight	3/8 MPT	11/16	13/16	1-13/16	20
MC-08-6	1/2	MPT-Straight	3/8 MPT	7/8	15/16	2-1/8	20
MC-08-8	1/2	MPT-Straight	1/2 MPT	7/8	15/16	2-1/8	20
MC-12-12*	3/4	MPT-Straight	3/4 MPT	1-1/4	1-3/8	2-1/4	10

*No Spring Guard Required

FC Female Connector

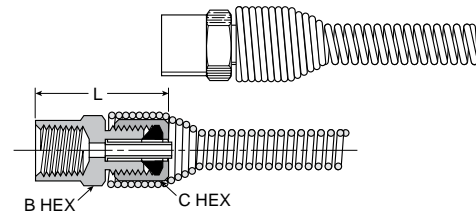

Part No.	Hose I.D.	End Type	End Size	B Hex	C Hex	L	Box Qty.
FC-04-4	1/4	Female Pipe FPT	1/4 FPT	11/16	9/16	1-9/16	10
FC-06-6	3/8	Female Pipe FPT	3/8 FPT	13/16	13/16	1-3/4	10

ME Male Elbow

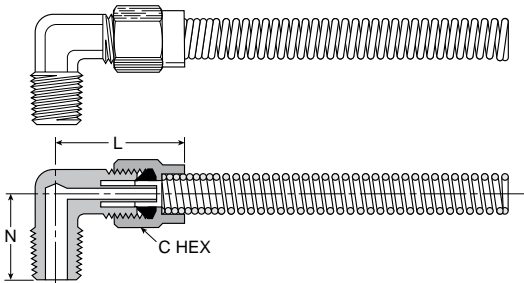

Part No.	Hose I.D.	End Type	End Size	C Hex	N	N	Box Qty.
ME-03-4	3/16	90° Male Elbow	1/4 MPT	9/16	1-1/4	15/16	20
ME-04-4	1/4	90° Male Elbow	1/4 MPT	9/16	1-13/16	15/16	20
ME-06-6	3/8	90° Male Elbow	3/8 MPT	13/16	1-9/16	1-1/8	20
ME-08-8	1/2	90° Male Elbow	1/2 MPT	15/16	1-3/4	1-3/8	20

FL Female Pipe Swivel

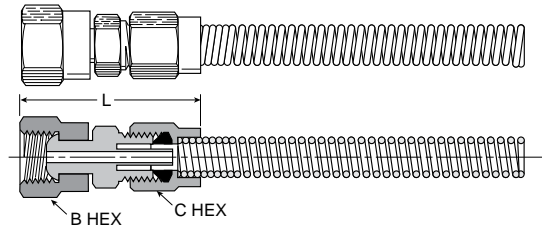

Part No.	Hose I.D.	End Type	End Size	B Hex	C Hex	L	Box Qty.
FL-04-4	1/4	Female NPSM 30° Swivel	1/4 NPSM	5/8	9/16	1-3/4	20
FL-06-6	3/8	Female NPSM 30° Swivel	3/8 NPSM	3/4	9/16	2-1/8	10

UC Union Connector

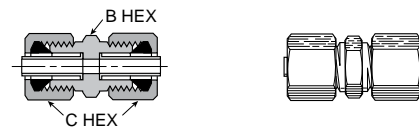

Part No.	Hose I.D.	End Type	End Size	B Hex	C Hex	L	Box Qty.
UC-04-4	1/4	Union Connector	1/4 x 1/4 I.D. Hose	1/2	9/16	1-7/8	10
UC-06-6	3/8	Union Connector	3/8 x 3/8 I.D. Hose	11/16	13/16	2-5/16	10

ML Live Male Pipe Swivel

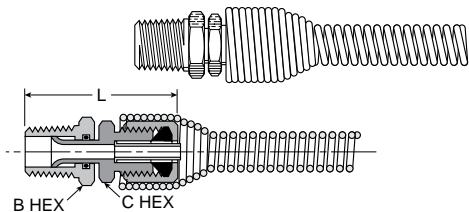

Part No.	Hose I.D.	End Type	End Size	B Hex	C Hex	L	Box Qty.
ML-03-4	3/16	MPT Live Swivel	1/4 MPT	9/16	1/2	1-11/16	20
ML-04-4	1/4	MPT Live Swivel	1/4 MPT	9/16	9/16	1-9/16	20
ML-06-6	3/8	MPT Live Swivel	3/8 MPT	3/4	13/16	1-7/8	20
ML-08-8	1/2	MPT Live Swivel	1/2 MPT	7/8	15/16	2-3/8	20



Replacement Parts

FN Brass Nuts



Hose Part No.	I.D.	Box Qty.
FN-03	3/16	20
FN-04	1/4	20
FN-06	3/8	20
FN-08	1/2	20
FN-12	3/4	10

TS Tube Support



Hose Part No.	I.D.	Box Qty.
TS-03	3/16	100
TS-04	1/4	100
TS-06	3/8	100
TS-08	1/2	100
TS-12	3/4	100

FR Plastic Ferrule



Hose Part No.	I.D.	Box Qty.
FR-03	3/16	50
FR-04	1/4	50
FR-06	3/8	30
FR-08	1/2	20
FR-12	3/4	10

SG Steel Spring Guard

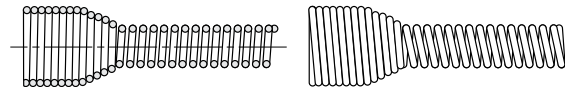

Hose Part No.	I.D.	Box Qty.
SG-03	3/16	20
SG-04	1/4	20
SG-06	3/8	20
SG-08	1/2	20

F

Advantages

Chemical resistant, flexible, low cost, eight colors, five tube sizes and choice of reel lengths.

Construction

Flexible polyethylene thermoplastic tubing is extruded from high molecular weight resin for increased dimensional stability, uniformity and long-term strength. Its resistance to environmental stress cracking greatly exceeds that of ordinary polyethylene tubing as measured by ASTM D-1693, (10% IGEPAL).

Applications & Approvals

Polyethylene tubing is available in black as well as seven coding colors as recommended by the Instrument Society of America. Black (EB) tubing contains an ultra-violet inhibitor which is recommended for use in sunlit areas. Ingredients of natural and color tubing (except black) listed below meet FDA requirements for food contact applications. All tubing conforms to ASTM D-1248, Type I, Class A, Category 4, Grade E5.

Temperature Range

Suggested operating temperature range is -80°F to 150°F (-62°C to 66°C).

Fitting Recommendation

- Brass fittings

Nomenclature

Part numbers are constructed from symbols that identify the style and size of the fitting. Letters identify style and material. Numbers identify size in 1/16's of an inch.

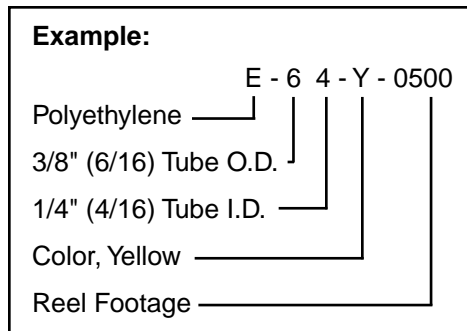

E Instrument Grade Tubing

Part Number	Color	O.D.	I.D.	Wall	Reel Length Feet	Working Pressure psi at 73°F	Min. Burst psi at 73°F	Min. Bend Radius Inches	Weight Per 100 Feet
E-43-0100	Natural	1/4	.170	.040	100	120	625	1	1.1
E-43-0500	Natural	1/4	.170	.040	500	120	625	1	1.1
E-43-1000	Natural	1/4	.170	.040	1000	120	625	1	1.1
EB-43-0100	Black	1/4	.170	.040	100	120	625	1	1.1
EB-43-0500	Black	1/4	.170	.040	500	120	625	1	1.1
EB-43-1000	Black	1/4	.170	.040	1000	120	625	1	1.1
E-43-R-0100	Red	1/4	.170	.040	100	120	625	1	1.1
E-43-R-0500	Red	1/4	.170	.040	500	120	625	1	1.1
E-43-B-0100	Blue	1/4	.170	.040	100	120	625	1	1.1
E-43-B-0500	Blue	1/4	.170	.040	500	120	625	1	1.1
E-43-O-0500	Orange	1/4	.170	.040	500	120	625	1	1.1
E-43-Y-0500	Yellow	1/4	.170	.040	500	120	625	1	1.1
E-43-P-0500	Purple	1/4	.170	.040	500	120	625	1	1.1
E-43-G-0500	Green	1/4	.170	.040	500	120	625	1	1.1
E-53-0500	Natural	5/16	.187	.062	500	145	800	1-1/8	2.1
EB-53-0500	Black	5/16	.187	.062	500	145	800	1-1/8	2.1
E-64-0100	Natural	3/8	.250	.062	100	125	675	1-1/4	2.5
E-64-0500	Natural	3/8	.250	.062	500	125	675	1-1/4	2.5
EB-64-0100	Black	3/8	.250	.062	100	125	675	1-1/4	2.5
EB-64-0500	Black	3/8	.250	.062	500	125	675	1-1/4	2.5
E-64-R-0500	Red	3/8	.250	.062	500	125	675	1-1/4	2.5
E-64-B-0500	Blue	3/8	.250	.062	500	125	675	1-1/4	2.5
E-64-O-0500	Orange	3/8	.250	.062	500	125	675	1-1/4	2.5
E-64-Y-0500	Yellow	3/8	.250	.062	500	125	675	1-1/4	2.5
E-64-P-0500	Purple	3/8	.250	.062	500	125	675	1-1/4	2.5
E-64-G-0500	Green	3/8	.250	.062	500	125	675	1-1/4	2.5
E-86-0100	Natural	1/2	.375	.062	100	90	425	2-1/2	3.6
EB-86-0100	Black	1/2	.375	.062	100	90	425	2-1/2	3.6
E-108-0100	Natural	5/8	.500	.062	100	70	325	4	4.6
EB-108-0100	Black	5/8	.500	.062	Coil	70	325	4	4.6

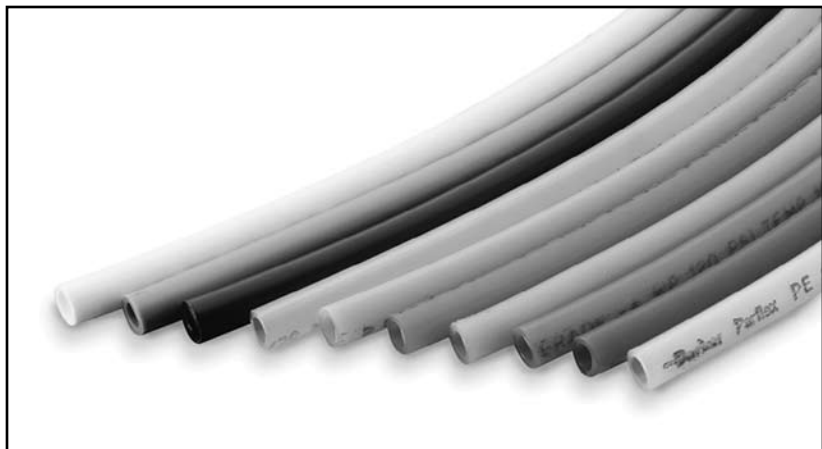



FRPE Flame Resistant Tubing

Part Number	Color	O.D.	I.D.	Wall	Reel Length Feet	Working Pressure psi at 73°F	Min. Burst psi at 73°F	Min. Bend Radius Inches	Weight Per 100 Feet
FRPE2.5-0500	Black	5/32	.096	.030	500	225	900	1/2	.56
FRPE4-0250	Black	1/4	.170	.040	250	160	650	3/4	1.24
FRPE4-0500	Black	1/4	.170	.040	500	160	650	3/4	1.24
FRPE4-1000	Black	1/4	.170	.040	1000	160	650	3/4	1.24
FRPE6-0250	Black	3/8	.250	.062	250	195	780	1-1/2	2.90
FRPE6-0500	Black	3/8	.250	.062	500	195	780	1-1/2	2.90
FRPE8-0250	Black	1/2	.375	.062	250	135	540	1-3/4	4.05

Construction & Approvals

Flame resistant polyethylene is manufactured from a distinctively formulated compound which meets the UL94 V-2 flame classification. It also meets the flame spread, fuel contribution and smoke density requirements of the ASTM E84-81a tunnel test.

Applications

Parker series FRPE tubing is the preferred product for pneumatic control applications in the heating - ventilating - air conditioning - energy conservation industry. It is also suitable for use in petrochemical plants, petroleum refineries, pulp and paper mills, mines, steel mills and other industries where protection against intermittent flame and hot sparks is necessary.

Temperature Range

Suggested operating temperature range is -85°F to 150°F (-65°C to +66°C).

Nomenclature

Order by tubing part number and name.



Example:

FR PE 4 - 0500

Flame Resistant ———┐

Polyethylene ———┐

1/4" (4/16) Tube O. D. ———┐

Reel Footage ———┐





Advantages

Flexible nylon tubing is carefully made from high-grade, abrasion-resistant, heat-and light-stabilized nylon. Resistance to stress-cracking greatly exceeds that of ordinary nylon tubing. Extremely low level water absorption.

Chemical-resistant nylon tubing has the additional benefits of better flexibility, lighter weight and resistance to flexural fatigue.

Colors

Available in natural (NN) and black (NB). Black tubing is recommended for use outdoors and in sunlit areas.

Temperature Range

Operating temperatures, depending upon conditions, are -65°F to 200°F (-54°C to 93°C) continuous.

Fitting Recommendations

- Brass fittings

Nomenclature

Order by tubing part number and name.

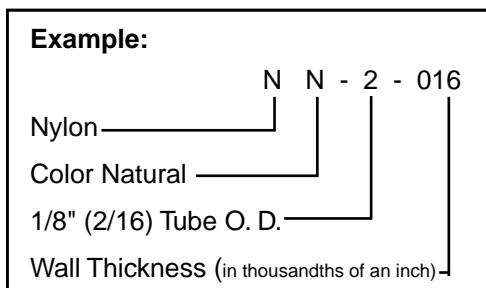

N Flexible Tubing

Nylon Part No.	Color	Nom. Tube O.D.	Nom. Tube I.D.	Average Wall Thick.	*Min. Burst Pressure at 73°F psi	Min. Bend Radius Inches	Std. Reel Length Feet
NN-2-016	Natural	1/8	.093	.016	1000	1/4	250
NB-2-016	Black	1/8	.093	.016	1000	1/4	250
NN-2-031	Natural	1/8	.064	.031	2000	1/4	250
NB-2-031	Black	1/8	.064	.031	2000	1/4	250
NN-2.5-025	Natural	5/32	.106	.025	1200	1/2	250
NB-2.5-025	Black	5/32	.106	.025	1200	1/2	250
NN-3-025	Natural	3/16	.138	.025	1000	5/8	250
NB-3-025	Black	3/16	.138	.025	1000	5/8	250
NN-3-046	Natural	3/16	.096	.046	2000	7/16	250
NB-3-046	Black	3/16	.096	.046	2000	7/16	250
NN-4-035	Natural	1/4	.180	.035	1000	7/8	250
NB-4-035	Black	1/4	.180	.035	1000	7/8	250
NN-4-040	Natural	1/4	.170	.040	1250	7/8	250
NB-4-040	Black	1/4	.170	.040	1250	7/8	250
NN-4-062	Natural	1/4	.127	.062	2000	1/2	250
NB-4-062	Black	1/4	.127	.062	2000	1/2	250
NN-5-040	Natural	5/16	.233	.040	1250	1-1/8	250
NB-5-040	Black	5/16	.233	.049	1250	1-1/8	250
NN-6-050	Natural	3/8	.275	.050	1250	1-1/8	250
NB-6-050	Black	3/8	.275	.050	1250	1-1/8	250
NN-6-093	Natural	3/8	.190	.093	2000	3/4	250
NB-6-093	Black	3/8	.190	.093	2000	3/4	250
NN-8-062	Natural	1/2	.375	.062	1000	1-1/4	250
NB-8-062	Black	1/2	.375	.062	1000	1-1/4	250
NN-8-124	Natural	1/2	.253	.124	2000	1	250
NB-8-124	Black	1/2	.253	.124	2000	1	250

*Suggested working pressure is 1/4 of burst pressure.





Advantages

Series NR semi-rigid nylon tubing offers better chemical resistance than series N, good resistance to high ambient temperature and low moisture absorption. NR has a high tensile strength which will give excellent coupling retention in high pressure, temperature and vibration environments.

Construction

Parker series NR tubing is manufactured from a semi-rigid nylon II material. The tubing does not contain plasticizers.

Applications & Approvals

NR tubing is specified for machine tool lubricating systems, marine control systems, process lines for chemicals and oils and other applications requiring a high quality nylon tube.

Temperature Range

The recommended operating temperature range for service at rated pressures with compatible fluids is -60°F to 200°F (-51°C to 93°C).

Fitting Recommendations

- Brass fittings

Nomenclature

Order by tubing part number and name.

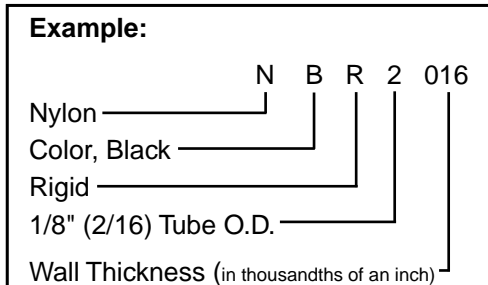

NR Semi-rigid High Strength Tubing

Nylon Part No.	Color	Nom. Tube O.D.	Nom. Tube I.D.	Average Wall Thick.	*Min. Burst Pressure at 73°F psi	Min. Bend Radius Inches	Std. Reel Length Feet
NNR-2-017	Natural	1/8	.091	.017	1700	1/2	500
NBR-2-017	Black	1/8	.091	.017	1700	1/2	500
NNR-2-026	Natural	1/8	.073	.026	2500	3/8	500
NBR-2-026	Black	1/8	.073	.026	2500	3/8	500
NNR-3-024	Natural	3/16	.140	.024	1700	3/4	500
NBR-3-024	Black	3/16	.140	.024	1700	3/4	500
NNR-3-039	Natural	3/16	.110	.039	2500	5/8	500
NBR-3-039	Black	3/16	.110	.039	2500	5/8	500
NNR-4-035	Natural	1/4	.180	.035	1700	1	250
NBR-4-035	Black	1/4	.180	.035	1700	1	250
NNR-4-050	Natural	1/4	.150	.050	2500	7/8	250
NBR-4-050	Black	1/4	.150	.050	2500	7/8	250
NNR-5-040	Natural	5/16	.233	.040	1700	1-1/2	250
NBR-5-040	Black	5/16	.233	.040	1700	1-1/2	250
NNR-6-048	Natural	3/8	.279	.048	1700	1-3/4	250
NBR-6-048	Black	3/8	.279	.048	1700	1-3/4	250
NNR-6-075	Natural	3/8	.225	.075	2500	1-1/2	250
NBR-6-075	Black	3/8	.225	.075	2500	1-1/2	250
NNR-8-062	Natural	1/2	.376	.062	1500	2-3/8	250
NBR-8-062	Black	1/2	.376	.062	1500	2-3/8	250
NNR-8-075	Natural	1/2	.350	.075	2200	2-1/2	250
NBR-8-075	Black	1/2	.350	.075	2200	2-1/2	250

*Suggested working pressure is 1/4 of burst pressure.

PTC Plastic Tube Cutter

Part No. PTC-001

An easy to handle razor/edged tube cutter, closes automatically, assuring clean and square cuts.

May be used with polyethylene, polypropylene, nylon and other plastic tubing.

How To Use

Insert plastic tube to desired length, allow tube cutter to close, then apply pressure until tube snaps off.

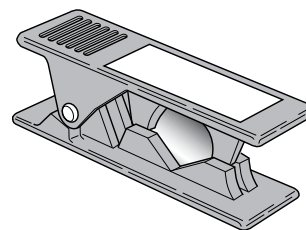

F



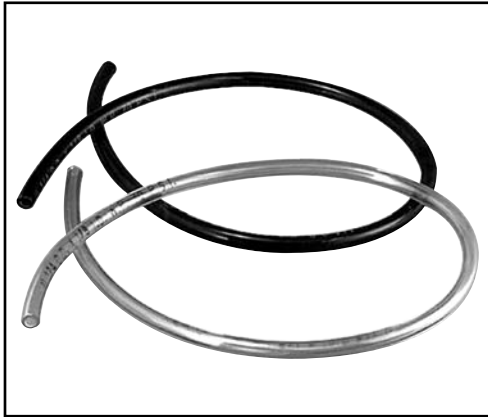

Advantages

Polyurethane tubing is a high quality, precision-made tubing used in a wide range of demanding and critical applications.

Polyether based, polyurethane tubing occupies a unique position among polymers, sharing the best properties of both rubber and plastic. Urethane exhibits the elongation and recovery characteristics of rubber and the chemical resistance associated with plastics. The tubing is tough, strong, kink-resistant and abrasion resistant, yet it's flexible and easy to assemble onto designated fittings.

- Tough
- Flexible
- Broad Temperature Range
- Eight Colors
- Abrasion Resistant
- Chemical Resistant

Applications & Approvals

Polyurethane tubing is used for a wide variety of applications. Typical usage includes air tools, robotics, pneumatic logic and actuation systems, analytical instrumentation, vacuum equipment, pressure measurement apparatus, semi-conductor equipment manufacturers and a variety of medical and laboratory applications.

Temperature Range

Suggested operating temperatures, depending upon conditions are 0°F to 200°F (-18°C to 93°C).

Fitting Recommendations

- Thermoplastic fittings
- Brass fittings

Nomenclature

Order by tubing part number and name.

Example:

U - 2 1 - BLK - 0250

Polyurethane _____

1/8" (2/16) Tube O.D. _____

1/6" (1/16) Tube I.D. _____

Color - Black _____

Reel Length in Feet _____

U Polyether Base Tubing

Part No.*	Nom. Tube O.D.	Nom. Tube I.D.	Wall Thick.	Working** Pressure (PSI)	Burst Pressure (PSI)	Reel Length Feet
U-21-0500	1/8	1/16	1/32	125	375	500
U-21-0250						250
U-42-0500	1/4	1/8	1/16	125	375	500
U-42-0250						250
U-64-0250	3/8	1/4	1/16	125	375	250
U-64-0100						100 (coil)
U-86-0250	1/2	3/8	1/16	85	255	250
U-86-0100						100 (coil)

* Colors: Clear-Blank, Black-BLK, Green-GRN, Red-RED, Yellow-YEL, Blue-BLU, Orange-ORG, Gray-GRA

** Based on a full 4:1 safety factor.



Nylon Semi-Rigid Tubing

NR Series (NNR, NBR)
1/8 thru 1/2 O.D. Inches

**Minimum
Burst Pressure
(psig)
(Thousands)**

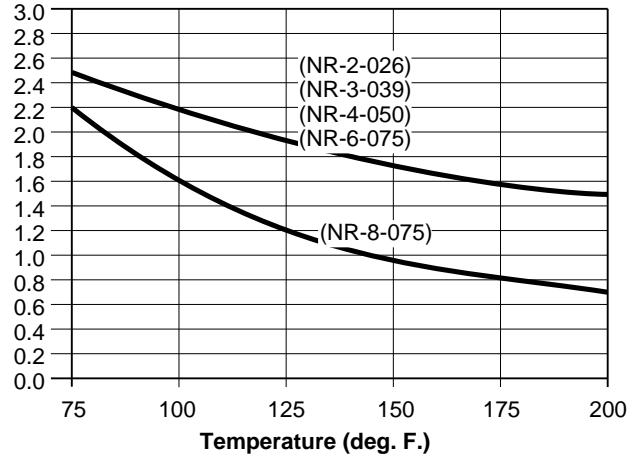

Nylon Flexible Tubing

N Series (NN, NB)
1/8 thru 1/2 O.D. Inches

**Minimum
Burst
Pressure
(psig)**

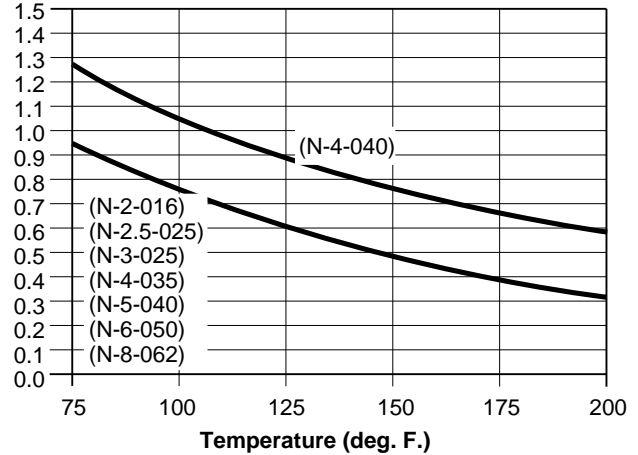

Nylon Semi-Rigid Tubing

NR Series (NNR, NBR)
1/8 thru 1/2 O.D. Inches

**Minimum
Burst Pressure
(psig)
(Thousands)**

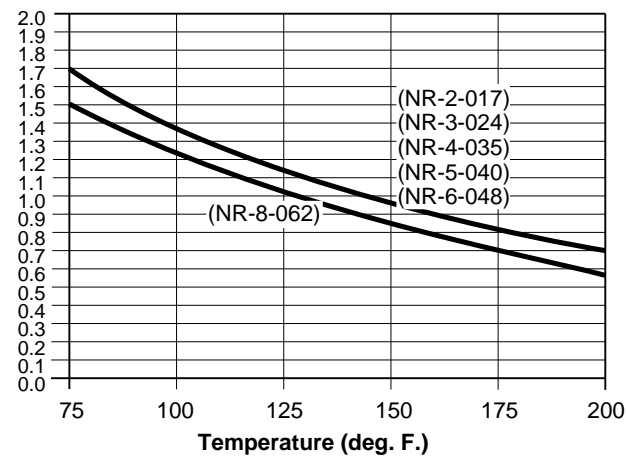

Nylon Flexible Tubing

N Series
1/8 thru 1/2 O.D. Inches

**Minimum
Burst
Pressure
(psig)**

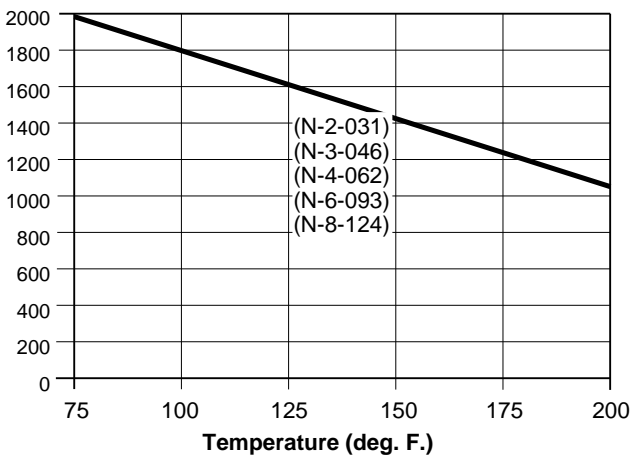

Suggested working pressures are 1/4 of burst pressure at system operating temperature.

F

Polyethylene Tubing

Laboratory Grade E Series
1/4 thru 5/8 O.D. Inches

**Minimum
Burst
Pressure
(psig)**

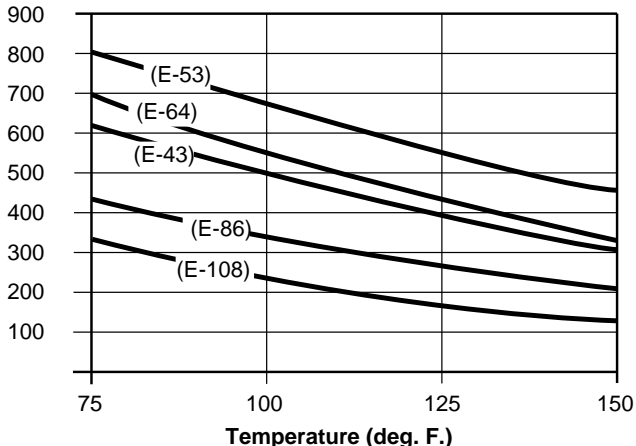

Polyurethane Tubing

"U" Series Polyether Base 4
1/8 thru 1/4 O.D. Inches

**Minimum
Burst
Pressure
(psig)**

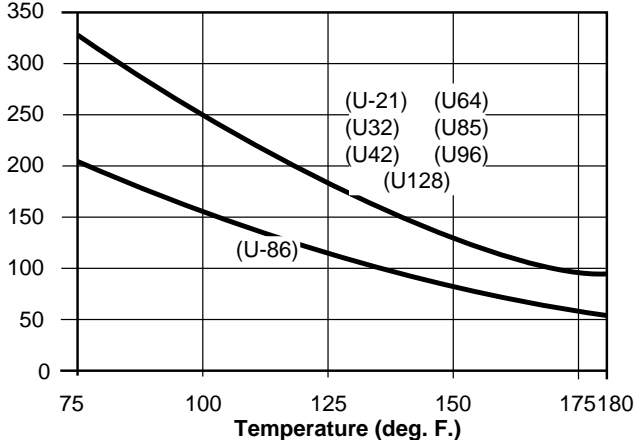

Polyethylene Tubing

Flame Resistant FRPE Series
1/4 thru 5/8 O.D. Inches

**Minimum
Burst
Pressure
(psig)**

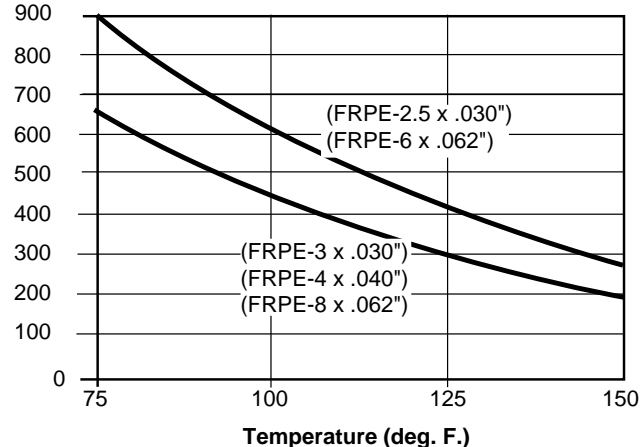

Suggested working pressure of polyethylene is 1/3 of burst pressure at system operating temperature.



	All Brass Body Fittings (Except Prestolok) Rating	Prestolok Fitting Rating		All Brass Body Fittings (Except Prestolok) Rating	Prestolok Fitting Rating
Acetic Acid	4	4	Citric Acid	3	3
Acetic Anhydride	4	4	Coffee	1	4
Acetone	1	4	Copper Chloride	4	4
Alum	4	4	Copper Sulfate	4	4
Aluminum Chloride	4	4	Corn Oil	2	2
Aluminum Sulfate	4	4	Cottonseed Oil	2	2
Ammonium Hydroxide	4	4	Creosote	2	2
Ammonium Chloride	4	4	Crude Oil	3	3
Ammonium Nitrate	4	4	Ethers	1	4
Ammonium Sulfate	4	4	Ethyl Acetate	2	4
Amyl Acetate	2	4	Ethyl Chloride	3	3
Aniline	3	4	Ethylene Glycol	2	2
Aniline Dyes	3	4	Ferric Chloride	4	4
Asphalt	1	2	Formaldehyde	3	3
Barium Chloride	4	4	Furfural	3	4
Beer	2	4	Gelatine	1	1
Beet Sugar Syrups	2	2	Glucose	1	1
Benzoic Acid	2	4	Glycerine	1	1
Black Liquor, Sulfate Process	4	4	Hydrobromic Acid	4	4
Bleaching Powder, Wet	4	4	Hydrochloric Acid	4	4
Borax	1	2	Hydrocyanic Acid	4	4
Bordeaux Mixture	2	2	Hydrofluoric Acid	4	4
Boric Acid	2	2	Hydrofluosilicic Acid	4	4
Bromine, Dry	1	4	Hydrogen Peroxide	3	4
Bromine, Moist	4	4	Hydrogen Sulfide, Moist	3	4
Butyric Acid	3	4	Lacquers	1	4
Calcium Bisulfite	4	4	Lacquer Solvents	1	4
Calcium Chloride	4	4	Lactic Acid Cold	3	3
Calcium Hydroxide	2	2	Lime	1	1
Calcium Hypochlorite	4	4	Lime-Sulfur	2	4
Cane Sugar Syrups	2	2	Linseed Oil	2	2
Carbolic Acid	2	4	Magnesium Chloride	4	4
Carbon Dioxide, Dry	1	1	Magnesium Hydroxide	1	2
Carbon Dioxide, Moist	3	3	Magnesium Sulfate	3	3
Carbon Disulfide	1	4	Methyl Chloride, Dry	1	4
Carbon Tetrachloride, Moist	4	4	Milk	2	4
Castor Oil	1	1	Nitric Acid	4	4
Chlorine, Dry	1	4	Nitrogen	1	1
Chlorine, Moist	4	4	Oleic Acid	3	3
Chloroacetic Acid	4	4	Oxalic Acid	3	3
Chloroform, Dry	1	4	Palmitic Acid	3	3

Ratings Code

- 1 — SATISFACTORY
- 2 — FAIR
- 3 — RECOMMEND TESTING
- 4 — UNSATISFACTORY

F

	All Brass Body Fittings (Except Prestolok) Rating	Prestolok Fitting Rating		All Brass Body Fittings (Except Prestolok) Rating	Prestolok Fitting Rating
Phosphoric Acid	4	4	Sodium Sulfite	4	4
Potassium Chloride	4	4	Sodium Thiosulfate	2	2
Potassium Cyanide	4	4	Steam	3	4
Potassium Dichromate, Acid	4	4	Stearic Acid	3	3
Potassium Hydroxide	3	3	Sulfur, Dry	1	4
Potassium Sulfate	2	2	Sulfur Chloride, Dry	1	4
Sea Water	3	3	Sulfur Dioxide, Dry	1	4
Soap Solutions	2	2	Sulfur Dioxide, Moist	4	4
Sodium Bicarbonate	3	3	Sulfur Trioxide, Dry	1	4
Sodium Bisulfate	4	4	Sulfuric Acid	4	4
Sodium Bisulfite	4	4	Sulfurous Acid	4	4
Sodium Carbonate	2	2	Tar	2	2
Sodium Chloride	4	4	Tartaric Acid	3	3
Sodium Cyanide	4	4	Toluene	1	4
Sodium Hydroxide	3	3	Trichloroacetic Acid	4	4
Sodium Hypochlorite	4	4	Trichlorethylene, Dry	1	3
Sodium Nitrate	3	3	Trichlorethylene, Moist	3	3
Sodium Peroxide	4	4	Vinegar	4	4
Sodium Phosphate	2	2	Zinc Chloride	4	4
Sodium Silicate	2	2	Zinc Sulfate	4	4

Ratings Code

- 1 — SATISFACTORY
- 2 — FAIR
- 3 — RECOMMEND TESTING
- 4 — UNSATISFACTORY

This brass compatibility chart is a ready reference for brass fittings with various media. It is intended as a guide to chemical compatibility and has been compiled from the best available sources. Many factors (concentration, temperature, intermittent or continuous exposure, etc.) have a bearing upon the suitability of any material and, therefore, no guarantee, expressed or implied, is made to compatibility in any specific set of circumstances.

Media	PB, Mini-PB			Media	PB, Mini-PB		
	PB Polyethylene Rating	Nylon Rating	Mini-PB Rating		PB Polyethylene Rating	Nylon Rating	Mini-PB Rating
Acetaldehyde	L	L	G	Carbon Dioxide	G	G	G
Acetates	G	L	G	Carbon Disulfide	L	L	L
Acetic Acid	G	L	G	Carbon Tetrachloride	P	L	G
Acetic Anhydride	G	P	G	Caustic Potash	G	G	G
Acetone	G	L	G	Caustic Soda	G	G	G
Acetyl Bromide	L	L	L	Chloracetic Acid	G	L	L
Acetyl Chloride	L	L	L	Chlorine (Dry)	L	L	L
Air	G	G	G	Chlorine (Wet)	L	L	L
Alcohols	G	G	G	Chlorobenzene	L	L	L
Aluminum Salts	G	G	G	Chloroform	L	L	G
Ammonia	G	G	G	Chromic Acid	L	P	L
Amyl Acetate	G	L	G	Copper Salts	G	G	G
Aniline	G	L	L	Cresol	L	L	L
Animal Oils	G	G	L	Cyclohexanone	L	L	L
Arsenic Salts	G	G	G	Ethers	L	L	G
Aromatic Hydrocarbons	L	L	L	Ethyl Acetate	G	L	G
Barium Salts	G	G	G	Ethyl Alcohol	G	L	G
Benzaldehyde	L	L	L	Ethylamine	G	L	L
Benzene (Benzol)	L	L	L	Ethyl Bromide	L	L	L
Benzyl Alcohol	G	L	L	Ethyl Chloride	L	L	L
Bleaching Liquors	L	L	G	Fatty Acids	L	G	L
Boric Acid Solutions	G	G	G	Ferric Salts	G	G	G
Bromine	L	L	L	Formaldehyde	G	L	G
Butane	G	P	G	Formic Acid	G	L	G
Butanol	G	G	G	Freon	L	L	L
Butyl Acetate	G	G	G	Gasoline	G	G	L
Calcium Salts	G	G	G				

Ratings Code

- G — Good to excellent. Little or no swelling, tensile or surface changes. Preferred choice.
- L — Marginal or conditional. Noticeable effects but not necessarily indicating lack of serviceability. Further testing suggested for specific application. Very long term effects such as stiffening or potential for crazing should be evaluated.
- P — Poor or unsatisfactory. Not recommended without extensive and realistic testing.
- — Not tested.

F

Media	PB Polyethylene Rating	PB, Mini-PB Nylon Rating	Mini-PB Polypropylene Rating	Media	PB Polyethylene Rating	PB, Mini-PB Nylon Rating	Mini-PB Polypropylene Rating
Glucose	G	G	G	Oils (Vegetable)	L	L	L
Glycerine	G	G	G	Oxygen	G	G	G
Hydriodic Acid (Conc.)	G	P	G	Perchloric Acid	G	P	L
Hydrochloric Acid	G	L	G	Phenol	G	P	G
Hydrochloric Acid (Med. Conc.)	G	L	G	Potassium Salts	G	G	G
Hydrofluoric Acid	L	P	G	Pyridine	L	L	L
Hydrogen Peroxide (Conc.)	G	L	L	Silver Nitrate	G	G	G
Hydrogen Peroxide (Dil.)	G	L	L	Soap Solutions	G	G	G
Hydrogen Sulfide	G	G	G	Sodium Salts	G	G	G
Iodine	G	G	G	Stearic Acid	L	G	L
Kerosene	L	G	L	Sulfur Chloride	L	L	L
Ketones	G	G	G	Sulfuric Acid (Conc.)	G	P	G
Lacquer Solvent	L	L	L	Sulfuric Acid (Dil.)	G	G	G
Lactic Acid	G	G	G	Sulfurous Acid	G	L	L
Lead Acetate	G	G	G	Tannic Acid	G	G	G
Linseed Oil	G	G	G	Tanning Extracts	G	G	G
Magnesium Salts	G	G	G	Titanium Salts	G	G	G
Naphtha	L	G	L	Toluene (Toluol)	L	L	L
Natural Gas	L	G	L	Trichloroacetic Acid	L	P	L
Nickel Salts	G	G	G	Trichlorethylene	L	G	L
Nitric Acid (Conc.)	L	P	L	Turpentine	L	G	L
Nitric Acid (Dil.)	G	L	L	Urea	G	G	G
Nitrobenzene	L	L	G	Uric Acid	G	G	G
Nitrogen Oxides	L	L	G	Water	G	G	G
Nitrous Acid	L	L	G	Xylene (Xylol)	L	L	L
Oils (Animal and Mineral)	L	G	L	Zinc Chloride	G	G	G

Ratings Code

- G — Good to excellent. Little or no swelling, tensile or surface changes. Preferred choice.
- L — Marginal or conditional. Noticeable effects but not necessarily indicating lack of serviceability. Further testing suggested for specific application. Very long term effects such as stiffening or potential for crazing should be evaluated.
- P — Poor or unsatisfactory. Not recommended without extensive and realistic testing.
- — Not tested.

Technical Information

Media	E "E" Series Polyethylene Rating	FRPE Flame Resistant Polyethylene Rating	N Nylon "N" Rating	NR Nylon "NR" Rating	U Polyurethane Rating
Acetaldehyde	L	—	L	G	L
Acetates	G	—	L	G	L
Acetic Acid	L	—	L	G	L
Acetic Anhydride	L	—	P	L	P
Acetone	G	L	L	G	P
Acetyl Bromide	L	—	L	—	—
Acetyl Chloride	L	—	L	—	—
Air	G	G	G	G	G
Alcohols	G	G	G	G	G
Aluminum Salts	G	G	G	G	G
Ammonia	G	L	G	G	G
Amyl Acetate	G	—	L	G	L
Aniline	L	—	L	L	P
Animal Oils	L	—	G	G	G
Arsenic Salts	G	G	G	G	G
Aromatic Hydrocarbons	P	P	L	G	G
Barium Salts	G	G	G	G	G
Benzaldehyde	P	P	L	G	L
Benzene (Benzol)	P	P	L	G	L
Benzyl Alcohol	P	P	L	L	L
Bleaching Liquors	G	—	L	L	L
Boric Acid Solutions	G	G	G	G	G
Bromine	L	—	L	P	P
Butane	L	—	P	G	P
Butanol	G	G	G	G	G
Butyl Acetate	G	G	G	G	L
Calcium Salts	G	G	G	G	G
Carbon Dioxide	G	G	G	G	G
Carbon Disulfide	L	—	L	G	L
Carbon Tetrachloride	P	P	L	L	L
Caustic Potash	G	—	G	G	G
Caustic Soda	G	—	G	G	G
Chloroacetic Acid	L	—	L	L	P
Chlorine (Dry)	L	—	L	P	L
Chlorine (Wet)	L	—	L	P	L
Chlorobenzene	P	P	L	L	L
Chloroform	P	P	L	L	L
Chromic Acid	L	—	P	P	P
Copper Salts	G	G	G	G	G
Cresol	P	P	L	P	P
Cyclohexanone	L	—	L	G	P
Ethers	L	—	L	G	L
Ethyl Acetate	G	—	L	G	L
Ethyl Alcohol	G	G	L	G	G
Ethylamine	L	—	L	L	L
Ethyl Bromide	P	P	L	L	—
Ethyl Chloride	P	P	L	L	—
Fatty Acids	L	P	G	G	G
Ferric Salts	G	—	G	G	G
Formaldehyde	G	—	L	G	G
Formic Acid	L	G	L	P	P
Freon	L	—	L	G	L
Gasoline	P	P	G	G	L

Ratings Code

- G — Good to excellent. Little or no swelling, tensile or surface changes. Preferred choice.
- L — Marginal or conditional. Noticeable effects but not necessarily indicating lack of serviceability. Further testing suggested for specific application. Very long term effects such as stiffening or potential for crazing should be evaluated.
- P — Poor or unsatisfactory. Not recommended without extensive and realistic testing.
- — Not tested.



Media	E "E" Series Polyethylene	FRPE Flame Resistant Polyethylene	N Nylon "N"	NR Nylon "NR"	U Polyurethane
Glucose	G	G	G	G	G
Glycerine	G	G	G	G	G
Hydriodic Acid	L	—	P	L	—
Hydrochloric Acid (Conc.)	L	—	L	L	L
Hydrochloric Acid (Med. Conc.)	L	—	L	G	L
Hydrofluoric Acid	L	—	P	P	P
Hydrogen Peroxide (Conc.)	L	—	L	G	G
Hydrogen Peroxide (Dil.)	L	—	L	G	G
Hydrogen Sulfide	G	—	G	G	P
Iodine	L	—	G	G	L
Kerosene	L	—	G	G	G
Ketones	G	—	G	G	P
Lacquer Solvent	L	—	L	L	—
Lactic Acid	G	—	G	G	G
Lead Acetate	G	—	G	G	G
Linseed Oil	L	—	G	G	G
Magnesium Salts	G	—	G	G	G
Naphtha	L	G	G	G	G
Natural Gas	L	—	G	G	G
Nickel Salts	G	—	G	G	G
Nitric Acid (Conc.)	P	G	P	P	P
Nitric Acid (Dil.)	P	P	L	L	P
Nitrobenzene	P	P	L	L	P
Nitrogen Oxides	L	—	L	L	—
Nitrous Acid	L	—	L	L	L
Oils (Animal and Mineral)	L	—	G	G	G
Oils (Vegetable)	L	—	L	G	G
Oxygen	G	G	G	G	G
Perchloric Acid	P	P	P	P	P
Phenol	P	P	P	P	P
Potassium Salts	G	G	G	G	G
Pyridine	L	—	L	L	P
Silver Nitrate	G	G	G	G	G
Soap Solutions	G	G	G	G	G
Sodium Salts	G	G	G	G	G
Stearic Acid	L	—	G	G	L
Sulfur Chloride	L	—	L	L	—
Sulfuric Acid (Conc.)	P	P	P	P	P
Sulfuric Acid (Dil.)	P	P	G	L	L
Sulfurous Acid	P	P	L	L	L
Tannic Acid	G	—	G	G	P
Tanning Extracts	G	—	G	G	P
Titanium Salts	G	G	G	G	G
Toluene (Toluol)	P	P	L	G	L
Trichloroacetic Acid	L	—	P	P	P
Trichlorethylene	P	P	G	L	P
Turpentine	L	—	G	G	G
Urea	G	—	G	G	G
Uric Acid	G	—	G	G	G
Water	G	G	G	G	G
Xylene (Xylol)	P	P	L	G	G
Zinc Chloride	G	—	G	G	G

Ratings Code

- G — Good to excellent. Little or no swelling, tensile or surface changes. Preferred choice.
- L — Marginal or conditional. Noticeable effects but not necessarily indicating lack of serviceability. Further testing suggested for specific application. Very long term effects such as stiffening or potential for crazing should be evaluated.
- P — Poor or unsatisfactory. Not recommended without extensive and realistic testing.
- — Not tested.



**Products-
Government & Agency Approvals**

Agency and Specifications	Approved Products
Flame Resistance: UL94V-2	Tubing: FRPE
Dry Food Contact: FDA, CFR21 Part 177.	Tubing: E Fittings: PB (Nylon & Polyethylene)
Potable Water, Liquid Foods: NSF Std. 14, 42, 53 NSF Std. 51	Tubing: N, P, U Fittings: PB (Nylon & Polyethylene)

F

⚠ DANGER: Failure or improper selection or improper use of hose, fittings, or related accessories can cause death, personal injury and property damage.

Possible consequences of failure or improper selection or improper use of hose, fittings or related accessories include but are not limited to:

- Fittings thrown off at high speed.
- High velocity fluid discharge.
- Explosion or burning of the conveyed fluid.
- Electrocution from high voltage electric power lines or other sources of electricity.
- Contact with suddenly moving or falling objects that are to be held in position or moved by the conveyed fluid.
- Dangerously whipping hose.
- Contact with conveyed fluids that may be hot, cold, toxic or otherwise injurious.
- Sparking or explosion caused by static electricity buildup.
- Sparking or explosion while paint or flammable liquid spraying.

Before selecting or using any hose or fittings or related accessories, it is important that you read and follow the instructions in the Guide below.

1.0 GENERAL INSTRUCTIONS

1.1 Scope: This guide provides instructions for selecting and using (including assembling, installing, and maintaining) hose (including all rubber and/or plastic products commonly called "hose" or "tubing"), fittings (including all products commonly called "fittings" or "couplings" for attachment to hose), and related accessories (including crimping and swaging machines and tooling). This guide is a supplement to and is to be used with, the specific publications for the specific hose, fittings and related accessories that are being considered for use.

1.2 Fail-Safe: Hose and hose assemblies can and do fail without warning for many reasons. Design all systems and equipment in a fail-safe mode, so that failure of the hose or hose assembly will not endanger persons or property.

1.3 Distribution: Provide a copy of this guide to each person that is responsible for selecting or using hose and fitting products. Do not select or use hose and fittings without thoroughly reading and understanding this guide as well as the specific publications for the products considered or selected.

1.4 User Responsibility: Due to the wide variety of operating conditions and uses for hose and fittings, the manufacturer and its distributors do not represent or warrant that any particular hose or fitting is suitable for any specific and use system. This guide does not analyze all technical parameters that must be considered in selecting a product. The user, through their own analysis and testing, are solely responsible for:

- Making the final selection of the hose and fitting.
- Assuring that the user's requirements are met and that the use presents no health or safety hazards.
- Providing all appropriate health and safety warnings on the equipment on which the hose and fittings are used.

1.5 Additional Questions: Consult the supplier if you have any additional questions or require additional information.

2.0 HOSE AND FITTING SELECTION INSTRUCTIONS

2.1 Electrical Conductivity: Certain applications require that a hose be nonconductive to prevent electrical current flow. Other applications require the hose to be sufficiently conductive to drain off static electricity. Extreme care must be exercised when selecting hose and fittings for these or any other applications in which electrical conductivity or nonconductivity is a factor.

For applications that require hose to be electrically nonconductive, including but not limited to applications near high voltage electric lines, only special nonconductive hose can be used. The manufacturer of the equipment in which the nonconductive hose is to be used must be consulted to be certain that the hose and fittings that are selected are proper for the application. Do not use any hose or fitting for any such application requiring nonconductive hose, including but not limited to applications near high voltage electric lines, unless (I) the application is expressly approved in the technical publication for the product, (II) the hose is both orange color and marked "nonconductive", and (III) the manufacturer of the equipment on which the hose is to be used specifically approves the particular hose and fitting for such use.

The manufacturer does not supply any hose or fittings for conveying

paint in airless paint spraying or similar applications, and hose and fittings must not be so used. A special hose and fitting assembly is required for this application, to avoid static electricity buildup. If the proper hose and fitting assembly is not used for this application, static electricity can build up and cause a spark that may result in an explosion and/or fire.

The electrical conductivity or nonconductivity of hose and fittings is dependent upon many factors and may be susceptible to change. These factors include but are not limited to the various materials used to make the hose and the fittings, manufacturing methods (including moisture control), how the fittings contact the hose, age and amount of deterioration or damage or other changes, moisture content of the hose at any particular time, and other factors.

2.2 Pressure: Hose selection must be made so that the published maximum recommended working pressure of the hose is equal to or greater than the maximum system pressure. Surge pressures in the system higher than the published maximum recommended working pressure will cause failure or shorten hose life. Do not confuse burst pressure or other pressure values with working pressure and do not use burst pressure or other pressure values for this purpose.

2.3 Suction: Hoses used for suction applications must be selected to ensure that the hose will withstand the vacuum and pressure of the system. Improperly selected hose may collapse in suction application.

2.4 Temperature: Be certain that fluid and ambient temperatures, both steady and transient, do not exceed the limitations of the hose. Care must be taken when routing hose near hot objects such as manifolds.

2.5 Fluid Compatibility: Hose selection must assure compatibility of the hose tube, cover, reinforcement, and fittings with the fluid media used. See the fluid compatibility chart in the publication for the product being considered or used.

2.6 Permeation: Permeation (that is, see page through the hose) will occur from inside the hose to outside when hose is used with gases, liquid and gas fuels, and refrigerants (including but not limited to such materials as helium, fuel, oil, natural gas, or freon). This permeation may result in high concentrations of vapors which are potentially flammable, explosive, or toxic, and in loss of fluid. Dangerous explosions, fires, and other hazards can result when using the wrong hose for such applications. The system designer must take into account the fact that this permeation will take place and must not use hose if this permeation could be hazardous. The system designer must take into account all legal, government, insurance, or any other special regulations which govern the use of fuels and refrigerants. Never use a hose even though the fluid compatibility is acceptable without considering the potential hazardous effects that can result from permeation through the hose assembly.

Permeation of moisture from outside the hose to inside the hose will also occur in hose assemblies, regardless of internal pressure. If this moisture permeation would have detrimental effects (particularly but not limited to refrigeration and air conditioning systems), incorporation of sufficient drying capacity in the system or other appropriate system safeguards should be selected and used.



- 2.7 Size:** Transmission of power by means of pressurized fluid varies with pressure and rate of flow. The size of the components must be adequate to keep pressure losses to a minimum and avoid damage due to heat generation or excessive fluid velocity.
- 2.8 Routing:** Attention must be given to optimum routing to minimize inherent problems (kinking or flow restriction due to hose collapse). Freon® is a registered trademark of the E.I. DuPont De Nemours Co., Inc.
- 2.9 Environment:** Care must be taken to ensure that the hose and fittings are either compatible with or protected from the environment (that is, surrounding conditions) to which they are exposed. Environmental conditions include but are not limited to ultraviolet radiation, sunlight, heat, ozone, moisture, water, salt water, chemicals, and air pollutants that can cause degradation and premature failure.
- 2.10 Mechanical Loads:** External forces can significantly reduce hose life or cause failure. Mechanical loads which must be considered include excessive flexing, twist, kinking, tensile or side loads, bend radius, and vibration. Use of swivel type fittings or adapters may be required to ensure no twist is put into the hose. Applications must be tested prior to hose selection.
- 2.11 Physical Damage:** Care must be taken to protect hose from wear, snagging and cutting, which can cause premature hose failure.
- 2.13 Length:** When establishing a proper hose length, motion absorption, hose length changes due to pressure, and hose and machine tolerances must be considered.
- 2.14 Specifications and Standards:** When selecting hose and fittings, government, industry, and manufacturer specifications and recommendations must be reviewed and followed as applicable.
- 2.15 Hose Cleanliness:** Hose components may vary in cleanliness levels. Care must be taken to ensure that the assembly selected has an adequate level of cleanliness for the application.
- 2.16 Fire Resistant Fluids:** Some fire resistant fluids require the same hose as petroleum oil. Some use a special hose, while a few fluids will not work with any hose at all. See instructions 2.5 and 1.5. The wrong hose may fail after a very short service. In addition, all liquids may burn fiercely under certain conditions, and leakage may be hazardous.
- 2.17 Radiant Heat:** Hose can be heated to destruction without contact, by such nearby items as hot manifolds or molten metal. The same heat source may then initiate a fire. This can occur despite the presence of cool air around the hose.
- 2.18 Welding and Brazing:** Heating of plated parts, including hose fittings and adapters, above 450°F (232°C) such as during welding, brazing, or soldering may emit deadly gases.

2.19 Radiation: Radiation affects all materials used in hose assemblies. Since the long term effects may be unknown, do not expose hose assemblies to radiation.

3.0 HOSE AND FITTING ASSEMBLY AND INSTALLATION INSTRUCTIONS

- 3.1 Pre-Installation Inspection:** Prior to installation, a careful examination of the hose must be performed. All components must be checked for correct style, size, catalog number, and length. In addition, the hose must be examined for cleanliness, obstructions, blisters, cover looseness, or any other viable defects.
- 3.2 Hose and Fitting Assembly:** Do not assemble fittings onto a hose that is not specifically listed by the manufacturer for that fitting unless authorized in writing by the chief engineer. Do not assemble one manufacturer's fitting on another manufacturer's hose.

The published instructions must be followed for assembling fittings on the hose. These instructions are provided in the fitting catalog for the specific fitting being used.

- 3.3 Related Accessories:** Do not crimp or swage any hose or fitting with anything but the proper listed swage or crimp machine, and dies, and in accordance with published instructions. Do not crimp or swage one manufacturer's hose fitting with another's crimp or swage die unless authorized in writing by their chief engineer.
- 3.4 Parts:** Do not use any hose fitting part (including but not limited to socket, shell, nipple, or insert) except with the correct mating parts, in accordance with instructions, unless authorized in writing by the chief engineer of the appropriate manufacturer.
- 3.5 Reusable/Permanent:** Do not reuse any reusable hose product that has blown or pulled off a hose. Do not reuse a permanent (that is, crimped or swaged) hose fitting or any part thereof.
- 3.6 Minimum Bend Radius:** Installation of a hose at less than the minimum listed bend radius may significantly reduce the hose life. Particular attention must be given to preclude sharp bending at the hose/fitting juncture.
- 3.7 Twist Angle and Orientation:** Hose installations must be such that relative motion of machine components does not produce twisting.
- 3.8 Securement:** In many applications, it may be necessary to restrain, protect, or guide the hose to protect it from damage by unnecessary flexing, pressure surges, and contact with other mechanical components. Care must be taken to ensure such restraints do not introduce additional stress or wear points.
- 3.9 Proper Connection of Ports:** Proper physical installation of the hose requires a correctly installed port connection while ensuring that no twist or torque is transferred to the hose.
- 3.10 External Damage:** Proper installation is not complete without ensuring that tensile loads, side loads, kinking, flattening, potential abrasion, thread damage, or damage to sealing surfaces are corrected or eliminated. See instruction 2.10.
- 3.11 System Checkout:** All air entrapment in hydraulic lines must be eliminated, all systems must be pressurized to the maximum system pressure and checked for proper function and freedom from leaks. Personnel must stay out of potential hazardous areas while testing and using.

4.0 HOSE AND FITTING MAINTENANCE INSTRUCTIONS

- 4.1 Visual Inspection Hose/Fitting:** Any of the following conditions require immediate shut down and replacement of the hose assembly
- Fitting slippage on hose.
 - Damaged, cut or abraded cover (any reinforcement exposed).
 - Hard, stiff, heat cracked, or charred hose.
 - Cracked, damaged, or badly corroded fittings.
 - Leaks at fitting or in hose.
 - Kinked, crushed, flattened or twisted hose.
 - Blistered, soft, degraded, or loose cover.
- 4.2 Visual Inspection All Other:** The following items must be tightened, repaired or replaced as required:
- Leaking port conditions.
 - Remove excess dirt buildup.
 - Clamps, guards, shields.
 - System fluid level, fluid type and any air entrapment.
- 4.3 Functional Test:** Operate the system at maximum operating pressure and check for possible malfunctions and freedom from leaks. Personnel must avoid potential hazardous areas while testing and using.
- 4.4 Replacement Intervals:** Specific replacement intervals must be considered based on previous service life, government or industry recommendations, or when failure could result in unacceptable downtime, damage, or injury risk. See instructions 1.2.

Section F



Industrial Interchange Nipples.....	F210-F211
Sleevmatic Couplers.....	F212-F213
Saflomatic Couplers	F214-F215
Twist-Lock Quick Connect Couplings	F216-F217
Economatic Quick Connect Couplings	F218-F219



Industrial Interchange Nipples

Industrial interchange nipples conform to MIL-C4109 and are for use with either Sleevmatic or Saflomatic couplers. The industrial interchange nipples are completely interchangeable with similar nipples manufactured by other quick coupling manufacturers conforming to A-A-59439 (formerly known as MIL-C-4109F), ANSI/(NFPA) T3.20.14-1990, or ISO6150-B requirements.

Hardened wear points and solid barstock construction provide long service life. Precision machined surfaces and hardened load-bearing areas resist the effects of mechanical shock in the most rugged applications.

Female Pipe Thread

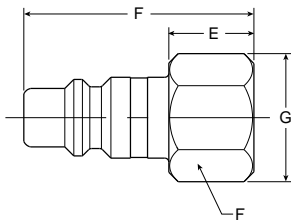

Male Pipe Thread

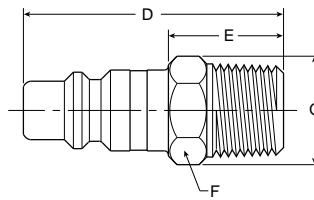

Body Size (Inches)	Part No. Steel	Thread Size	Overall Length D	Exposed Length* E	Hex Size F	Largest Diameter G
1/4	H1C	1/8-27	1.48	0.71	0.50	0.58
1/4	H3C	1/4-18	1.56	0.80	0.62	0.72
1/4	H3C-E	3/8-18	1.60	0.83	0.81	0.94
3/8	H1E	1/4-18	1.60	0.69	0.62	0.72
3/8	H3E	3/8-18	1.69	0.74	0.81	0.94
3/8	H3E-F	1/2-14	1.84	0.90	1.00	1.16
1/2	H1F	3/8-18	2.03	0.79	0.81	0.94
1/2	H3F	1/2-14	2.20	0.96	1.00	1.16
1/2	H3F-G	3/4-14	2.30	1.05	1.25	1.44
3/4	H3G-F	1/2-14	2.22	1.06	1.00	1.16
3/4	H3G	3/4-14	2.18	1.02	1.25	1.44
3/4	H3G-J	1-11½	2.41	1.25	1.63	1.80

* This dimension represents portion of nipple that is exposed when nipple is inserted in the coupler.

Body Size (Inches)	Part No. Steel	Thread Size	Overall Length D	Exposed Length* E	Hex Size F	Largest Diameter G
1/4	H0C	1/8-27	1.68	0.92	0.50	0.58
1/4	H2C	1/4-18	1.66	0.89	0.56	0.65
1/4	H2C-E	3/8-18	1.90	1.14	0.69	0.80
3/8	H00E	1/8-27	1.68	0.73	0.62	0.72
3/8	H0E	1/4-18	1.90	0.95	0.62	0.72
3/8	H2E	3/8-18	1.90	0.95	0.69	0.80
3/8	H2E-F	1/2-14	2.03	1.09	0.88	1.02
1/2	H0F	3/8-18	2.20	0.96	0.69	0.79
1/2	H2F	1/2-14	2.35	1.09	0.88	1.01
1/2	H2F-G	3/4-14	2.40	1.16	1.06	1.22
3/4	H2G-F	1/2-14	2.32	1.16	1.00	1.16
3/4	H2G	3/4-14	2.28	1.12	1.06	1.22
3/4	H2G-J	1-11½	2.56	1.40	1.31	1.52

* This dimension represents portion of nipple that is exposed when nipple is inserted in the coupler.

F

Industrial Interchange Nipples

Standard Hose Barb

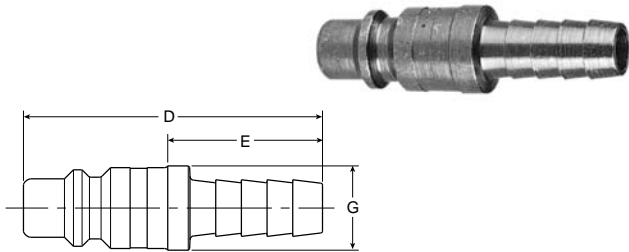

Body Size (Inches)	Part No. Steel	Hose I.D.	Overall Length D	Exposed Length* E	Largest Diameter G
1/4	H8C	1/4	1.72	0.95	0.46
1/4	H8C-D	5/16	1.96	1.20	0.50
1/4	H9C	3/8	1.96	1.20	0.50
3/8	H5E	3/8	1.85	0.90	0.59
3/8	H6E	1/2	2.09	1.14	0.68
1/2	H4F	3/8	2.36	1.12	0.66
1/2	H5F	1/2	2.36	1.12	0.66
1/2	H5F-G	3/4	2.95	1.71	0.87
3/4	H5G-F	1/2	2.47	1.31	0.93
3/4	H5G	3/4	3.00	1.84	0.93
3/4	H5G-J	1	3.24	2.08	1.24

* This dimension represents portion of nipple that is exposed when nipple is inserted in coupler.

Push-Lok Hose Barb**

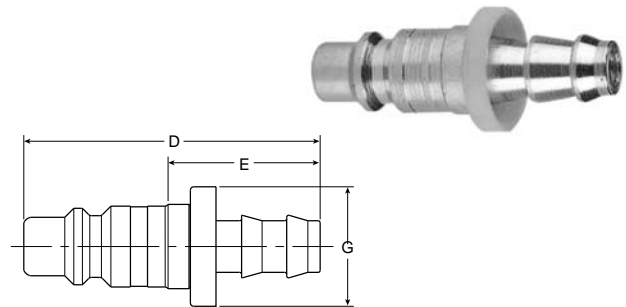

Body Size (Inches)	Part No. Steel	Hose I.D.	Overall Length D	Exposed Length* E	Largest Diameter G
1/4	H8CP	1/4	1.93	1.16	0.69
1/4	H9CP	3/8	2.08	1.31	0.86
3/8	H4EP	1/4	2.02	1.08	0.69
3/8	H5EP	3/8	2.17	1.23	0.88
3/8	H6EP	1/2	2.31	1.37	0.97
1/2	H4FP	3/8	2.52	1.27	0.88
1/2	H5FP	1/2	2.66	1.42	0.97
1/2	H6FP	1/2	2.95	1.71	1.14

* This dimension represents portion of nipple that is exposed when nipple is inserted in coupler.

** Push-Lok hose barbs are designed for use with a push-lok hose and do not require clamps.

Sleevmatic Couplers

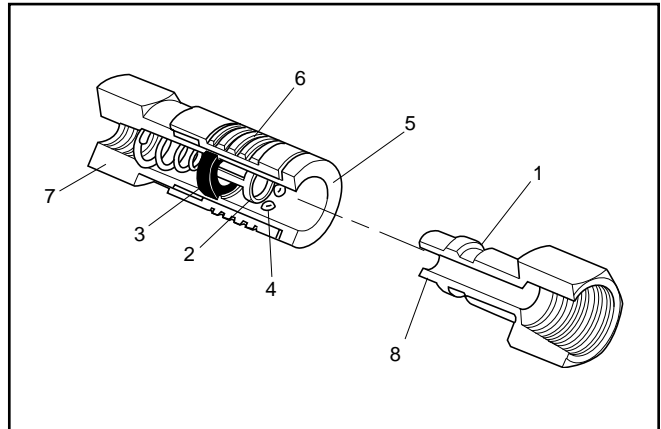
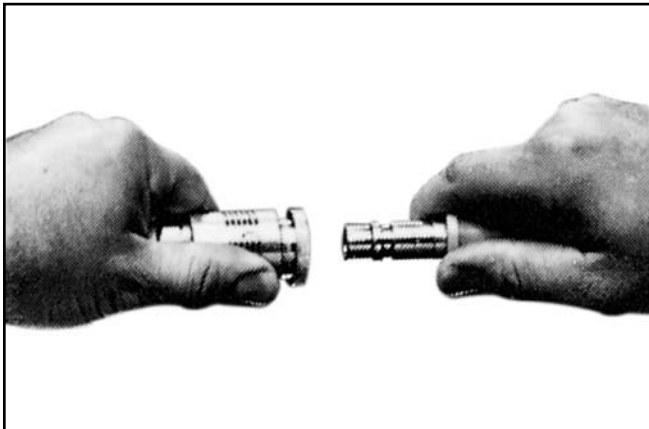

Operation

Sleeve type couplings are widely used to connect air and low-pressure fluid hose lines.

Their compact and economical design uses a ball locking mechanism consisting of captive steel balls that engage the locking groove on the mating nipple. As pictured, the sliding spring loaded sleeve on the coupler must be manually retracted in order to connect or disconnect the nipple. It is easy to do, but two hands are normally required.

Common applications include compressed air, water, grease, paint, limited vacuum and limited gases.

Features

1. Hardened wear points and solid barstock construction provide long life for these quality couplings. Precision machined surfaces resist the effects of mechanical shocks, even in rugged use.
2. Tubular valve with large flow passages delivers high air flows with minimal pressure drop for efficient performance.
3. Molded seals with high quality valve seats form a bubble tight seal for reliable sealing within rated working pressures. The tubular valve minimizes wear on the seal and prolongs seal life.

4. Ball locking mechanism with large numbers of steel or stainless steel locking balls improves resistance to wear, insures positive connections and provides accurate alignment. The ball locking also allows swiveling action that reduces hose torque.
5. Sleeve guard resists accidental disconnection by allowing the coupling to ride over obstructions without the sleeve being accidentally retracted. It also contributes to greater strength.
6. Knurling and grooves on sleeve provide gripping surfaces for ease of operation.
7. Wide range of sizes, materials and end terminations are available. Sleeve type quick couplings are offered with male pipe, female pipe, push-lok hose barb and standard hose barb ends. Materials offered are Nitrile, Ethylene, Propylene and Fluorocarbon for seals and brass or steel for metals.
8. Interchangeability. Sleevmatic couplers are used with industrial interchange nipples conforming to MIL-C4109.

Performance

Sleevmatic
1/4", 3/8", 1/2"

Specifications

	Body Size		
	1/4	3/8	1/2
Rated Pressure (psi)	300	300	300
Temperature Range			
Nitrile	-40°F to 250°F		
Ethylene Propylene	-65°F to 400°F		
Fluorocarbon	-30°F to 400°F		
Locking Device	4 Balls	8 Balls	8 Balls
Vacuum Data (inches Hg)*			
Disconnected (coupler only)	Not recommended		
Connected	27.4	27.4	27.4

* Couplings for vacuum service should be 100% tested – an extra cost service. Consult factory.

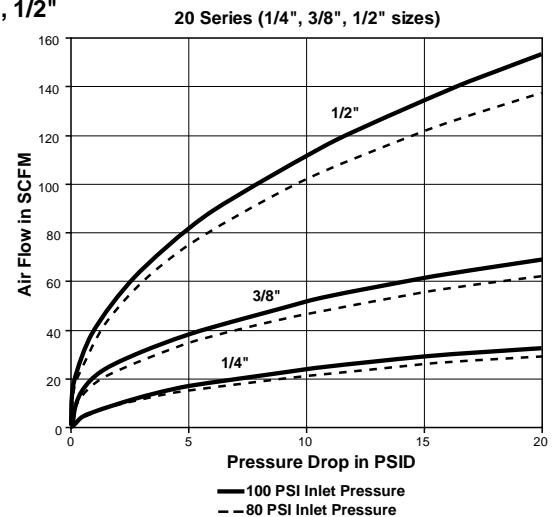

F

Sleevmatic Couplers

Female Pipe Thread

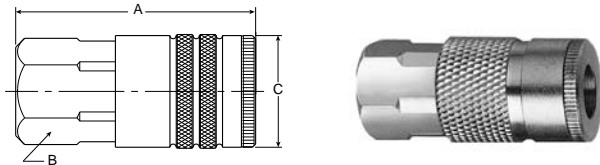

Body Size (Inches)	Part No.		Thread Size	Overall Length A	Hex Size B	Largest Diameter C
	Brass	Steel				
1/4	B23A	—	1/8-27	1.83	0.75	0.90
1/4	B23	—	1/4-18	1.83	0.75	0.90
1/4	B23E	—	3/8-18	1.95	0.81	0.94
3/8	—	25C	1/4-18	2.22	0.88	1.06
3/8	—	25	3/8-18	2.28	0.88	1.06
3/8	—	25F	1/2-14	2.55	1.00	1.16
1/2	—	17E	3/8-18	2.74	1.00	1.19
1/2	—	17	1/2-14	2.96	1.00	1.19
1/2	—	17G	3/4-14	3.19	1.25	1.44

Standard Hose Barb

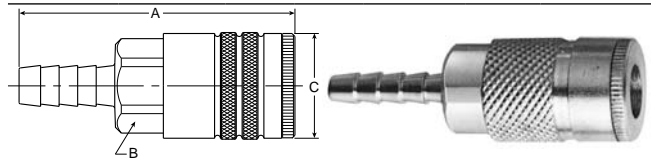

Body Size (Inches)	Part No.		Hose I.D.	Overall Length A	Hex Size B	Largest Diameter C
	Brass	Steel				
1/4	B20-3B	—	1/4	2.49	0.75	0.90
1/4	B20-4B	—	5/16	2.49	0.75	0.90
1/4	B20-5B	—	3/8	2.49	0.75	0.90
3/8	—	24-5B	3/8	2.86	0.88	1.06
3/8	—	24-6B	1/2	3.08	0.88	1.06
1/2	—	16-5B	3/8	3.37	1.00	1.19
1/2	—	16-6B	1/2	3.62	1.00	1.19
1/2	—	16-7B	3/4	3.96	1.00	1.19

Male Pipe Thread

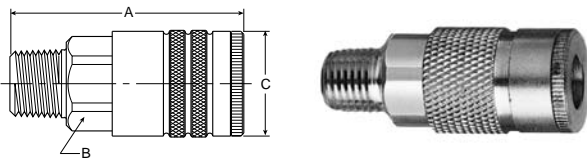

Body Size (Inches)	Part No.		Thread Size	Overall Length A	Hex Size B	Largest Diameter C
	Brass	Steel				
1/4	B22A	—	1/8-27	1.89	0.75	0.90
1/4	B22	—	1/4-18	2.05	0.75	0.90
1/4	B22E	—	3/8-18	2.08	0.75	0.90
3/8	—	24C	1/4-18	2.36	0.88	1.06
3/8	—	24	3/8-18	2.39	0.88	1.06
3/8	—	24F	1/2-14	2.55	0.88	1.06
1/2	—	16E	3/8-18	2.93	1.00	1.19
1/2	—	16	1/2-14	3.08	1.00	1.19
1/2	—	16G	3/4-14	3.21	1.13	1.30

NOTE:
 To indicate Fluorocarbon seals, add the letter Y as a suffix to the catalog number of the coupler. To indicate Ethylene Propylene seals, add the letter W as a suffix to the catalog number of the coupler.

Example: B23AY or B23AW

Push-Lok Hose Barb*

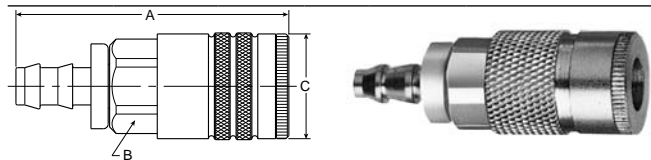

Body Size (Inches)	Part No.		Hose I.D.	Overall Length A	Hex Size B	Largest Diameter C
	Brass	Steel				
1/4	B20-3BP	—	1/4	2.32	0.75	0.90
1/4	B20-5BP	—	3/8	2.47	0.75	0.90
3/8	—	24-5BP	3/8	2.88	0.88	1.06
1/2	—	16-5BP	3/8	3.35	1.00	1.19
1/2	—	16-6BP	1/2	3.46	1.00	1.19

* Push-Lok hose barbs are designed for use with push-lok hose and do not require clamps.

NOTE:
 To indicate Fluorocarbon seals, add the letter Y as a suffix to the catalog number of the coupler. To indicate Ethylene Propylene seals, add the letter W as a suffix to the catalog number of the coupler.

Example: B20-3BY or B20-3BW

Repair Kits

Body Size	Nitrile	Fluorocarbon	Ethylene Propylene
1/4	21K	21KY	21KW
3/8	14K	—	14KW
1/2	16K	16KY	16KW

Safromatic Couplers

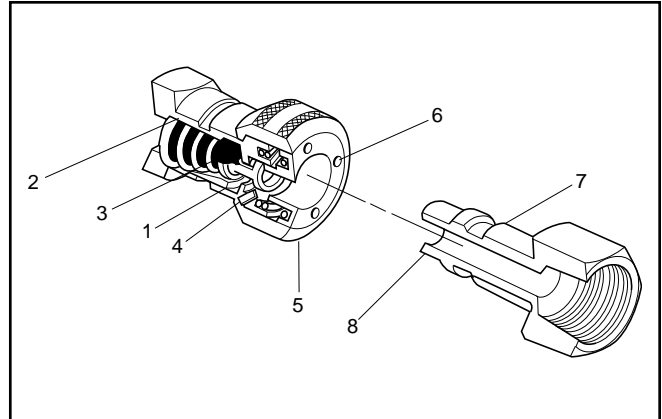
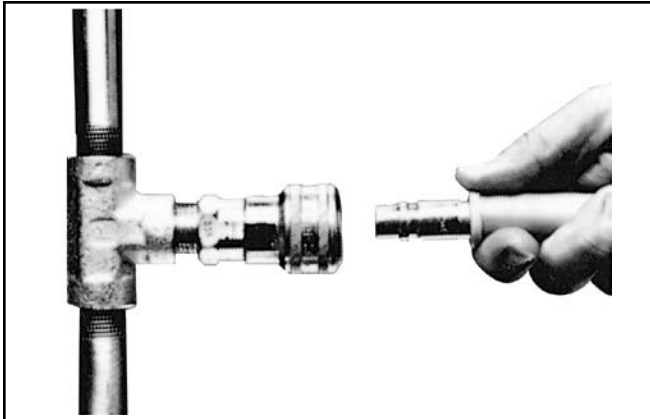

Operation

Push type couplings feature one-handed “automatic” connection by pushing the nipple into the coupler – provided the coupler half is firmly mounted.

The locking mechanism of Safromatic push type couplers consists of pawls or pins which act directly on the sleeve, thereby causing the sleeve to automatically retract when the mating nipple is inserted. The sleeve must be manually retracted in order to remove the nipple.

Safromatic couplings are push type “single shut off” couplings.

Common applications include compressed air, water, grease, paint, limited vacuum and limited gas.

Features

1. Safromatic tubular valves with their large flow windows deliver high air flow with minimum pressure drop – for efficient performance of air tools and other actuators. The tubular valve also provides 360 degree seal support to prevent cold flow and bore constriction, thereby extending seal life.

2. Tapered flow recesses in the valve body provide maximum flow capability.
3. Precision molded seals with high quality valve seats for a bubble tight seal that assures reliable sealing within rated working pressures. The Safromatic design with its 360° seal support gives maximum seal retention.
4. Locking pawls are of hardened stainless steel for a durable locking mechanism that provides good alignment and sideload resistance.
5. Push-to-connect design permits one-handed connection when the coupler half is rigidly mounted.
6. Back pressure vent holes allow easier connections especially with liquids.
7. Hardened wear points and solid barstock construction provide long life for these quality couplings. Precision machined surfaces resist the effects of mechanical shocks, even in rugged use.
8. Interchangeability. Safromatic couplers are used with industrial interchange nipples conforming to MIL-C4109.

Specifications

	Body Size			
	1/4	3/8	1/2	3/4
Rated Pressure (psi)	300	300	300	300
Temperature Range				
Nitrile	-40°F to 250°F			
Ethylene Propylene	-65°F to 400°F			
Fluorocarbon	-30°F to 400°F			
Locking Device	3	4	5	6
	pawls	pawls	pawls	pawls
Vacuum Data (inches Hg)*				
Disconnected (coupler only)	Not recommended			
Connected	27.4	27.4	27.4	27.4

* Couplings for vacuum service should be 100% tested – an extra cost service. Consult factory.

Performance

Safromatic
1/4" to 3/4"

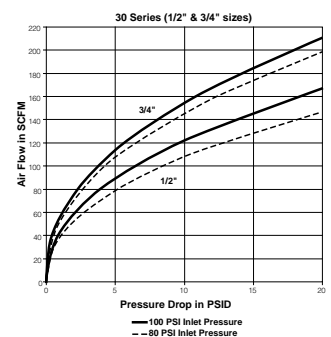
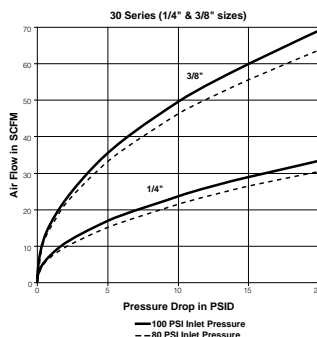

F



Safromatic Couplers

Female Pipe Thread

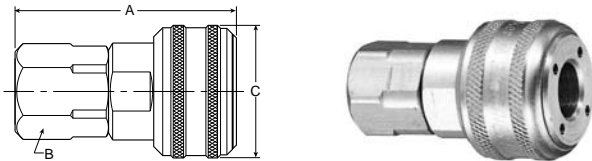

Body Size (Inches)	Part No. Brass	Thread Size	Overall Length A	Hex Size B	Largest Diameter C
1/4	B33A	1/8-27	1.96	0.75	1.20
1/4	B33	1/4-18	1.96	0.75	1.20
1/4	B33E	3/8-18	2.03	0.81	1.20
3/8	B35C	1/4-18	2.26	0.88	1.39
3/8	B35	3/8-18	2.33	0.88	1.39
3/8	B35F	1/2-14	2.57	1.00	1.39
1/2	B37E	3/8-18	2.76	1.00	1.52
1/2	B37	1/2-14	3.00	1.00	1.52
1/2	B37G	3/4-14	3.12	1.25	1.52
3/4	B39F	1/2-14	2.85	1.31	1.90
3/4	B39	3/4-14	2.99	1.31	1.90
3/4	B39J	1-11½	3.18	1.56	1.90

Standard Hose Barb

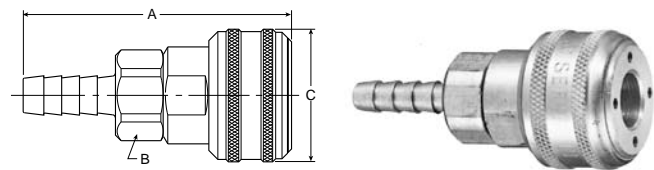

Body Size (Inches)	Part No. Brass	Hose I.D.	Overall Length A	Hex Size B	Largest Diameter C
1/4	B30-3B	1/4	2.62	0.75	1.20
1/4	B30-4B	5/16	2.62	0.75	1.20
1/4	B30-5B	3/8	2.62	0.75	1.20
3/8	B34-5B	3/8	2.85	0.88	1.39
3/8	B34-6B	1/2	2.85	0.88	1.39
1/2	B36-6B	1/2	3.33	1.00	1.52
1/2	B36-7B	3/4	3.86	1.00	1.52
3/4	B38-7B	3/4	3.69	1.31	1.90
3/4	B38-8B	1	3.93	1.31	1.90

Male Pipe Thread

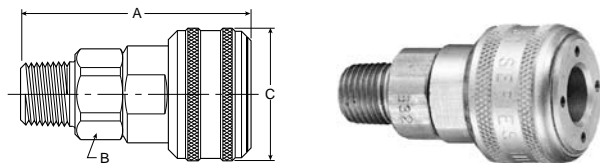

Body Size (Inches)	Part No. Brass	Thread Size	Overall Length A	Hex Size B	Largest Diameter C
1/4	B32A	1/8-27	2.03	0.75	1.20
1/4	B32	1/4-18	2.18	0.75	1.20
1/4	B32E	3/8-18	2.18	0.75	1.20
3/8	B34C	1/4-18	2.38	0.88	1.39
3/8	B34	3/8-18	2.44	0.88	1.39
3/8	B34F	1/2-14	2.57	0.88	1.39
1/2	B36E	3/8-18	2.92	1.00	1.52
1/2	B36	1/2-14	3.09	1.00	1.52
1/2	B36G	3/4-14	3.12	1.13	1.52
3/4	B38	3/4-14	2.95	1.31	1.90
3/4	B38J	1-11½	3.12	1.31	1.90

NOTE:
 To indicate Fluorocarbon seals, add the letter Y as a suffix to the catalog number of the coupler. To indicate Ethylene Propylene seals, add the letter W as a suffix to the catalog number of the coupler.

Example: B33AY or B33AW

Push-Lok Hose Barb*

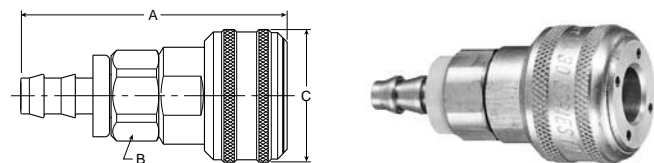

Body Size (Inches)	Part No. Brass	Hose I.D.	Overall Length A	Hex Size B	Largest Diameter C
1/4	B30-3BP	1/4	2.45	0.75	1.20
1/4	B30-5BP	3/8	2.60	0.75	1.20
3/8	B34-5BP	3/8	2.82	0.88	1.39
1/2	B36-6BP	1/2	3.46	1.00	1.52

* Push-Lok hose barbs are designed for use with push-lok hose and do not require clamps.

NOTE: To indicate Fluorocarbon seals, add the letter Y as a suffix to the catalog number of the coupler.

Example: B30-3BY

Repair Kits

Body Size	Nitrile	Fluorocarbon	Ethylene Propylene
1/4	21K	21KY	21KW
3/8	14K	14KY	14KW
1/2	16K	16KY	16KW
3/4	38K	38KY	38KW



Twist-Lock Quick Connect Couplings



Specifications

Body: Zinc

Sleeve and adapter: Zinc plated steel

Seals: Nitrile

Rated pressure: 300 PSI

Temperature: -40°F to 250°F

Application

Twist-Lock couplings are ideal for with air tools.

Operation

Push to connect. To disconnect – twist the coupler sleeve an 1/8 turn. Designed for compressed air use. Install couplers around your shop at strategic locations – on walls, work benches, columns, etc. Equip your pneumatic tools, etc. with mating nipples and simply plug into the couplers. Permits use of shorter, more manageable lengths of hose. Consult your distributor for other fluids.

Features

- Engineered for speedy connections.
Push in to lock . . . twist to unlock.
- Designed to protect against accidental uncoupling.
- 1/4 and 1/2 inch sizes available.

Flow Chart

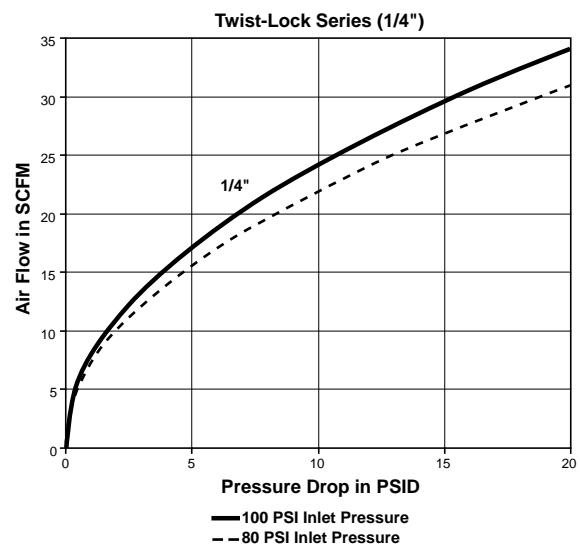

Twist-Lock Quick Connect Couplings

Coupler Female Thread



Part Number	Body Size	Pipe Thread	Overall Length	Maximum Diameter
TL-251-4FP	1/4	1/4-18 NPT	2.01	1.12
TL-501-6FP	1/2	3/8-18 NPT	2.55	1.50
TL-501-8FP	1/2	1/2-14 NPT	2.78	1.50
TL-501-12FP	1/2	3/4-14 NPT	2.41	1.50

Nipple Female Thread



Part Number	Body Size	Pipe Thread	Overall Length
TL-254-2FP	1/4	1/8-27 NPT	1.53
TL-254-4FP	1/4	1/4-18 NPT	1.81
TL-504-4FP	1/2	1/4-18 NPT	1.68
TL-504-6FP	1/2	3/8-18 NPT	1.84

Coupler Male Thread



Part Number	Body Size	Pipe Thread	Overall Length	Maximum Diameter
TL-251-4MP	1/4	1/4-18 NPT	2.23	1.12
TL-251-6MP	1/4	3/8-18 NPT	2.23	1.12
TL-501-6MP	1/2	3/8-18 NPT	2.71	1.50
TL-501-8MP	1/2	1/2-14 NPT	2.88	1.50

Nipple Standard Hose Barb



Part Number	Body Size	Hose I.D.	Overall Length
TL-254-4HB	1/4	1/4	1.83
TL-254-6HB	1/4	3/8	1.83
TL-504-4HB	1/2	1/4	2.31
TL-504-6HB	1/2	3/8	2.28
TL-504-8HB	1/2	1/2	2.28

Nipple Male Thread



Part Number	Body Size	Pipe Thread	Overall Length
TL-254-2MP	1/4	1/8-27 NPT	1.65
TL-254-4MP	1/4	1/4-18 NPT	1.75
TL-504-4MP	1/2	1/4-18 NPT	1.87
TL-504-6MP	1/2	3/8-18 NPT	1.93
TL-504-8MP	1/2	1/2-14 NPT	2.16
TL-504-12MP	1/2	3/4-14 NPT	2.16

Economatic Quick Connect Couplings

Description

Economatic couplings feature the tubular valve in a coupler body that interchanges with ARO 210 and similar design couplers and nipples. Economatic couplings are available only in 1/4" body size, but include 3/8" thread size. Economatic couplings have brass bodies with steel sleeves and valves for durability. Standard seal material is Nitrile.

Specifications

Body Size: 1/4"

Rated Pressure: 300 psi

Temperature Range

(Standard Seals): -40°F to 250°F

Locking Device: 4 balls

Couplers Female Pipe Thread

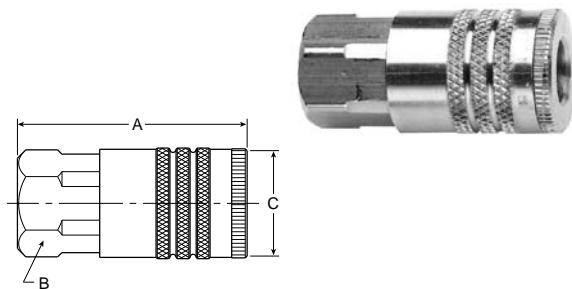

Body Size (Inches)	Part No. Brass	Thread Size	Overall Length A	Hex Size B	Largest Diameter C
1/4	B53	1/4-18 NPTF	1.83	0.75	0.90
1/4	B53E	3/8-18 NPTF	1.95	0.81	0.94

Couplers Push-Lok Hose Barb*

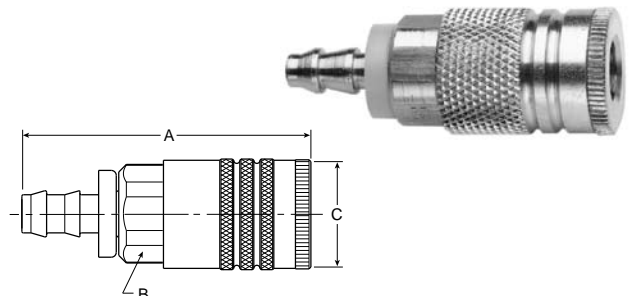

Body Size (Inches)	Part No. Brass	Hose I.D.	Overall Length A	Hex Size B	Largest Diameter C
1/4	B50-03BP	1/4	2.32	0.75	0.90
1/4	B50-05BP	3/8	2.47	0.75	0.90

* Push-Lok hose barbs are designed for use with push-lok hose and do not require clamps.

Couplers Male Pipe Thread

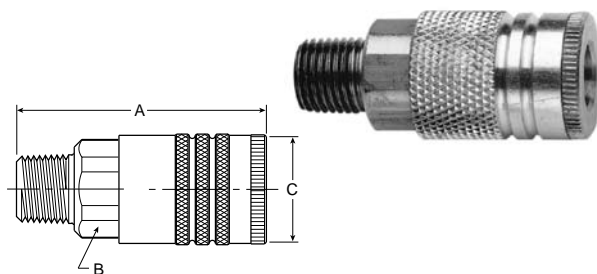

Body Size (Inches)	Part No. Brass	Thread Size	Overall Length A	Hex Size B	Largest Diameter C
1/4	B52	1/4-18	2.05	0.75	0.90
1/4	B52E	3/8-18	2.08	0.75	0.90

Flow Chart

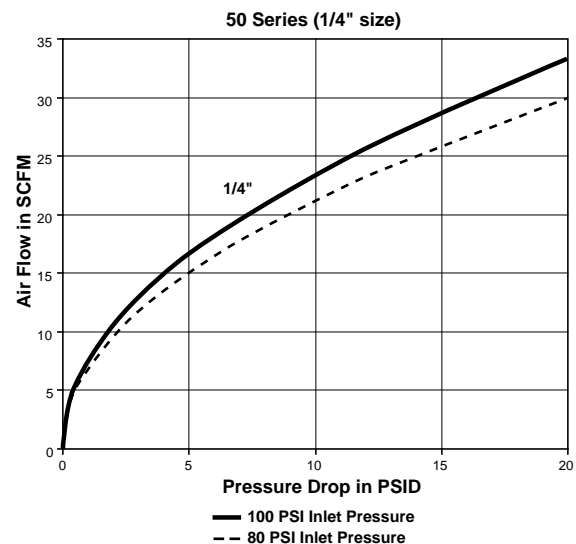

F

Economatic Quick Connect Couplings

Nipples Female Pipe Thread

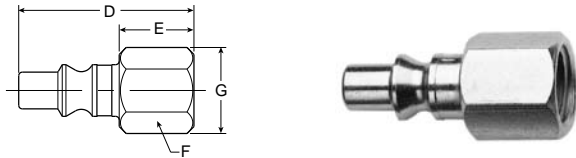

Body Size (Inches)	Part No. Steel	Thread Size	Overall Length D	Exposed Length* E	Hex Size F	Largest Diameter G
1/4	A3C	1/4-18	1.47	0.66	0.62	0.72

* This dimension represents portion of nipple that is exposed when nipple is inserted in coupler.

Nipples Standard Hose Barb

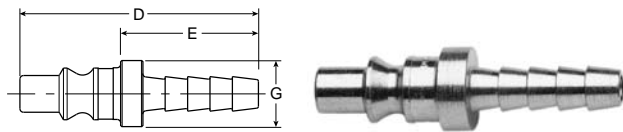

Body Size (Inches)	Part No. Steel	Hose I.D.	Overall Length D	Exposed Length* E	Largest Diameter G
1/4	A8C	1/4	1.63	0.85	0.43

* This dimension represents portion of nipple that is exposed when nipple is inserted in coupler.

Nipples Male Pipe Thread

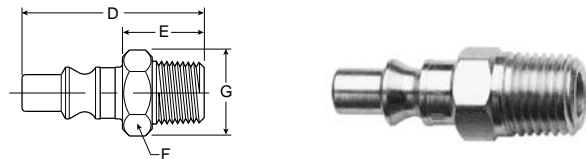

Body Size (Inches)	Part No. Steel	Thread Size	Overall Length D	Exposed Length* E	Hex Size F	Largest Diameter G
1/4	A2C	1/4-18	1.62	0.82	0.56	0.65

* This dimension represents portion of nipple that is exposed when nipple is inserted in coupler.

Nipples Push-Lok Hose Barb**

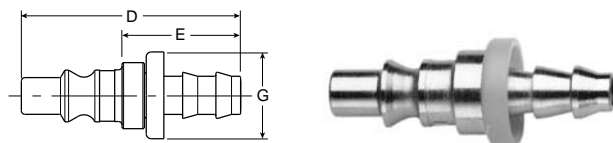

Body Size (Inches)	Part No. Steel	Hose I.D.	Overall Length D	Exposed Length* E	Largest Diameter G
1/4	A8CP	1/4	1.65	0.87	0.43

* This dimension represents portion of nipple that is exposed when nipple is inserted in coupler.

** Push-Lok barbs are designed for use with push-lok hose and do not require clamps.



Safety Guide For Selecting And Using Pneumatic Division Products And Related Accessories



WARNING:

FAILURE OR IMPROPER SELECTION OR IMPROPER USE OF PNEUMATIC DIVISION PRODUCTS, ASSEMBLIES OR RELATED ITEMS (“PRODUCTS”) CAN CAUSE DEATH, PERSONAL INJURY, AND PROPERTY DAMAGE. POSSIBLE CONSEQUENCES OF FAILURE OR IMPROPER SELECTION OR IMPROPER USE OF THESE PRODUCTS INCLUDE BUT ARE NOT LIMITED TO:

- Unintended or mistimed cycling or motion of machine members or failure to cycle
- Work pieces or component parts being thrown off at high speeds.
- Failure of a device to function properly for example, failure to clamp or unclamp an associated item or device.
- Explosion
- Suddenly moving or falling objects.
- Release of toxic or otherwise injurious liquids or gasses.

Before selecting or using any of these Products, it is important that you read and follow the instructions below.

1. GENERAL INSTRUCTIONS

- 1.1. Scope:** This safety guide is designed to cover general guidelines on the installation, use, and maintenance of Pneumatic Division Valves, FRLs (Filters pressure Regulators and Lubricators), Vacuum products and related accessory components.
- 1.2. Fail-Safe:** Valves, FRLs, Vacuum products and their related components can and do fail without warning for many reasons. Design all systems and equipment in a fail-safe mode, so that failure of associated valves, FRLs or Vacuum products will not endanger persons or property.
- 1.3 Relevant International Standards:** For a good guide to the application of a broad spectrum of pneumatic fluid power devices see: ISO 4414:1998, Pneumatic Fluid Power – General Rules Relating to Systems. See www.iso.org for ordering information.
- 1.4. Distribution:** Provide a copy of this safety guide to each person that is responsible for selection, installation, or use of Valves, FRLs or Vacuum products. Do not select, or use Watts valves, FRLs or vacuum products without thoroughly reading and understanding this safety guide as well as the specific Watts publications for the products considered or selected.
- 1.5. User Responsibility:** Due to the wide variety of operating conditions and applications for valves, FRLs, and vacuum products Watts and its distributors do not represent or warrant that any particular valve, FRL or vacuum product is suitable for any specific end use system. This safety guide does not analyze all technical parameters that must be considered in selecting a product. The user, through its own analysis and testing, is solely responsible for:
 - Making the final selection of the appropriate valve, FRL, Vacuum component, or accessory.
 - Assuring that all user's performance, endurance, maintenance, safety, and warning requirements are met and that the application presents no health or safety hazards.
 - Complying with all existing warning labels and / or providing all appropriate health and safety warnings on the equipment on which the valves, FRLs or Vacuum products are used; and,
 - Assuring compliance with all applicable government and industry standards.
- 1.6. Safety Devices:** Safety devices should not be removed, or defeated.
- 1.7. Warning Labels:** Warning labels should not be removed, painted over or otherwise obscured.
- 1.8. Additional Questions:** Call the appropriate Watts technical service department if you have any questions or require any additional information. See the Watts publication for the product being considered or used, or call 269-629-5000, or go to www.wattsfluidair.com, for telephone numbers of the appropriate technical service department.

2. PRODUCT SELECTION INSTRUCTIONS

- 2.1. Flow Rate:** The flow rate requirements of a system are frequently the primary consideration when designing any pneumatic system. System components need to be able to provide adequate flow and pressure for the desired application.
- 2.2. Pressure Rating:** Never exceed the rated pressure of a product. Consult product labeling, Pneumatic Division catalogs or the instruction sheets supplied for maximum pressure ratings.
- 2.3. Temperature Rating:** Never exceed the temperature rating of a product. Excessive heat can shorten the life expectancy of a product and result in complete product failure.
- 2.4. Environment:** Many environmental conditions can affect the integrity and suitability of a product for a given application. Pneumatic Division products are designed for use in general purpose industrial applications. If these products are to be used in unusual circumstances such as direct sunlight and/or corrosive or caustic environments, such use can shorten the useful life and lead to premature failure of a product.
- 2.5. Lubrication and Compressor Carryover:** Some modern synthetic oils can and will attack nitrile seals. If there is any possibility of synthetic oils or greases migrating into the pneumatic components check for compatibility with the seal materials used. Consult the factory or product literature for materials of construction.
- 2.6. Polycarbonate Bowls and Sight Glasses:** To avoid potential polycarbonate bowl failures:
 - Do not locate polycarbonate bowls or sight glasses in areas where they could be subject to direct sunlight, impact blow, or temperatures outside of the rated range.
 - Do not expose or clean polycarbonate bowls with detergents, chlorinated hydro-carbons, ketones, esters or certain alcohols.
 - Do not use polycarbonate bowls or sight glasses in air systems where compressors are lubricated with fire resistant fluids such as phosphate ester and di-ester lubricants.

Safety Guide

2.7. Chemical Compatibility: For more information on plastic component chemical compatibility see Pneumatic Division technical bulletins Tec-3, Tec-4, and Tec-5

2.8. Product Rupture: Product rupture can cause death, serious personal injury, and property damage.

- Do not connect pressure regulators or other Pneumatic Division products to bottled gas cylinders.
- Do not exceed the maximum primary pressure rating of any pressure regulator or any system component.
- Consult product labeling or product literature for pressure rating limitations.

3. PRODUCT ASSEMBLY AND INSTALLATION INSTRUCTIONS

3.1. Component Inspection: Prior to assembly or installation a careful examination of the valves, FRLs or vacuum products must be performed. All components must be checked for correct style, size, and catalog number. DO NOT use any component that displays any signs of nonconformance.

3.2. Installation Instructions: Watts published Installation Instructions must be followed for installation of Watts valves, FRLs and vacuum components. These instructions are provided with every Watts valve or FRL sold, or by calling 269-629-5000, or at www.wattsfluidair.com.

3.3. Air Supply: The air supply or control medium supplied to Valves, FRLs and Vacuum components must be moisture-free if ambient temperature can drop below freezing

4. VALVE AND FRL MAINTENANCE AND REPLACEMENT INSTRUCTIONS

4.1. Maintenance: Even with proper selection and installation, valve, FRL and vacuum products service life may be significantly reduced without a continuing maintenance program. The severity of the application, risk potential from a component failure, and experience with any known failures in the application or in similar applications should determine the frequency of inspections and the servicing or replacement of Pneumatic Division products so that products are replaced before any failure occurs. A maintenance program must be established and followed by the user and, at minimum, must include instructions 4.2 through 4.10.

4.2. Installation and Service Instructions: Before attempting to service or replace any worn or damaged parts consult the appropriate Service Bulletin for the valve or FRL in question for the appropriate practices to service the unit in question. These Service and Installation Instructions are provided with every Watts valve and FRL sold, or are available by calling 269-629-5000, or by accessing the Watts web site at www.wattsfluidair.com.

4.3. Lockout / Tagout Procedures: Be sure to follow all required lockout and tagout procedures when servicing equipment. For more information see: OSHA Standard – 29 CFR, Part 1910.147, Appendix A, The Control of Hazardous Energy – (Lockout / Tagout)

4.4. Visual Inspection: Any of the following conditions requires immediate system shut down and replacement of worn or damaged components:

- Air leakage: Look and listen to see if there are any signs of visual damage to any of the components in the system. Leakage is an indication of worn or damaged components.
- Damaged or degraded components: Look to see if there are any visible signs of wear or component degradation.
- Kinked, crushed, or damaged hoses. Kinked hoses can result in restricted air flow and lead to unpredictable system behavior.
- Any observed improper system or component function: Immediately shut down the system and correct malfunction.
- Excessive dirt build-up: Dirt and clutter can mask potentially hazardous situations.

Caution: Leak detection solutions should be rinsed off after use.

4.5. Routine Maintenance Issues:

- Remove excessive dirt, grime and clutter from work areas.
- Make sure all required guards and shields are in place.

4.6. Functional Test: Before initiating automatic operation, operate the system manually to make sure all required functions operate properly and safely.

4.7. Service or Replacement Intervals: It is the user's responsibility to establish appropriate service intervals. Valves, FRLs and vacuum products contain components that age, harden, wear, and otherwise deteriorate over time. Environmental conditions can significantly accelerate this process. Valves, FRLs and vacuum components need to be serviced or replaced on routine intervals. Service intervals need to be established based on:

- Previous performance experiences.
- Government and / or industrial standards.
- When failures could result in unacceptable down time, equipment damage or personal injury risk.

4.8. Servicing or Replacing of any Worn or Damaged Parts: To avoid unpredictable system behavior that can cause death, personal injury and property damage:

- Follow all government, state and local safety and servicing practices prior to service including but not limited to all OSHA Lockout Tagout procedures (OSHA Standard – 29 CFR, Part 1910.147, Appendix A, The Control of Hazardous Energy – Lockout / Tagout).
- Disconnect electrical supply (when necessary) before installation, servicing, or conversion.
- Disconnect air supply and depressurize all air lines connected to system and Pneumatic Division products before installation, service, or conversion.
- Installation, servicing, and / or conversion of these products must be performed by knowledgeable personnel who understand how pneumatic products are to be applied.
- After installation, servicing, or conversions air and electrical supplies (when necessary) should be connected and the product tested for proper function and leakage. If audible leakage is present, or if the product does not operate properly, do not put product or system into use.
- Warnings and specifications on the product should not be covered or painted over. If masking is not possible, contact your local representative for replacement labels.

4.9. Putting Serviced System Back into Operation: Follow the guidelines above and all relevant Installation and Maintenance Instructions supplied with the valve FRL or vacuum component to insure proper function of the system.



Offer of Sale

The items described in this document and other documents and descriptions provided by Parker Hannifin Corporation, its subsidiaries and its authorized distributors ("Seller") are hereby offered for sale at prices to be established by Seller. This offer and its acceptance by any customer ("Buyer") shall be governed by all of the following Terms and Conditions. Buyer's order for any item described in its document, when communicated to Seller verbally, or in writing, shall constitute acceptance of this offer. All goods or work described will be referred to as "Products".

1. Terms and Conditions. Seller's willingness to offer Products, or accept an order for Products, to or from Buyer is expressly conditioned on Buyer's assent to these Terms and Conditions and to the terms and conditions found on-line at www.parker.com/saleterms/. Seller objects to any contrary or additional term or condition of Buyer's order or any other document issued by Buyer.

2. Price Adjustments; Payments. Prices stated on the reverse side or preceding pages of this document are valid for 30 days. After 30 days, Seller may change prices to reflect any increase in its costs resulting from state, federal or local legislation, price increases from its suppliers, or any change in the rate, charge, or classification of any carrier. The prices stated on the reverse or preceding pages of this document do not include any sales, use, or other taxes unless so stated specifically. Unless otherwise specified by Seller, all prices are F.O.B. Seller's facility, and payment is due 30 days from the date of invoice. After 30 days, Buyer shall pay interest on any unpaid invoices at the rate of 1.5% per month or the maximum allowable rate under applicable law.

3. Delivery Dates; Title and Risk; Shipment. All delivery dates are approximate and Seller shall not be responsible for any damages resulting from any delay. Regardless of the manner of shipment, title to any products and risk of loss or damage shall pass to Buyer upon tender to the carrier at Seller's facility (i.e., when it's on the truck, it's yours). Unless otherwise stated, Seller may exercise its judgment in choosing the carrier and means of delivery. No deferral of shipment at Buyers' request beyond the respective dates indicated will be made except on terms that will indemnify, defend and hold Seller harmless against all loss and additional expense. Buyer shall be responsible for any additional shipping charges incurred by Seller due to Buyer's changes in shipping, product specifications or in accordance with Section 13, herein.

4. Warranty. Seller warrants that the Products sold hereunder shall be free from defects in material or workmanship for a period of twelve months from the date of delivery to Buyer or 2,000 hours of normal use, whichever occurs first. This warranty is made only to Buyer and does not extend to anyone to whom Products are sold after purchased from Seller. The prices charged for Seller's products are based upon the exclusive limited warranty stated above, and upon the following disclaimer: **DISCLAIMER OF WARRANTY: THIS WARRANTY COMPRISES THE SOLE AND ENTIRE WARRANTY PERTAINING TO PRODUCTS PROVIDED HEREUNDER. SELLER DISCLAIMS ALL OTHER WARRANTIES, EXPRESS AND IMPLIED, INCLUDING MERCHANTABILITY AND FITNESS FOR A PARTICULAR PURPOSE.**

5. Claims; Commencement of Actions. Buyer shall promptly inspect all Products upon delivery. No claims for shortages will be allowed unless reported to the Seller within 10 days of delivery. No other claims against Seller will be allowed unless asserted in writing within 60 days after delivery or, in the case of an alleged breach of warranty, within 30 days after the date within the warranty period on which the defect is or should have been discovered by Buyer. Any action based upon breach of this agreement or upon any other claim arising out of this sale (other than an action by Seller for any amount due to Seller from Buyer) must be commenced within thirteen months from the date of tender of delivery by Seller or, for a cause of action based upon an alleged breach of warranty, within thirteen months from the date within the warranty period on which the defect is or should have been discovered by Buyer.

6. LIMITATION OF LIABILITY. UPON NOTIFICATION, SELLER WILL, AT ITS OPTION, REPAIR OR REPLACE A DEFECTIVE PRODUCT, OR REFUND THE PURCHASE PRICE. IN NO EVENT SHALL SELLER BE LIABLE TO BUYER FOR ANY SPECIAL, INDIRECT, INCIDENTAL OR CONSEQUENTIAL DAMAGES ARISING OUT OF, OR AS THE RESULT OF, THE SALE, DELIVERY, NON-DELIVERY, SERVICING, USE OR LOSS OF USE OF THE PRODUCTS OR ANY PART THEREOF, OR FOR ANY CHARGES OR EXPENSES OF ANY NATURE INCURRED WITHOUT SELLER'S WRITTEN CONSENT, EVEN IF SELLER HAS BEEN NEGLIGENT, WHETHER IN CONTRACT, TORT OR OTHER LEGAL THEORY. IN NO EVENT SHALL SELLER'S LIABILITY UNDER ANY CLAIM MADE BY BUYER EXCEED THE PURCHASE PRICE OF THE PRODUCTS.

7. Contingencies. Seller shall not be liable for any default or delay in performance if caused by circumstances beyond the reasonable control of Seller.

8. User Responsibility. The user, through its own analysis and testing, is solely responsible for making the final selection of the system and Product and assuring that all performance, endurance, maintenance, safety and warning requirements of the application are met. The user must analyze all aspects of the application and follow applicable industry standards and Product information. If Seller provides Product or system options, the user is responsible for determining that such data and specifications are suitable and sufficient for all applications and reasonably foreseeable uses of the Products or systems.

9. Loss to Buyer's Property. Any designs, tools, patterns, materials, drawings, confidential information or equipment furnished by Buyer or any other items which become Buyer's property, may be considered obsolete and may be destroyed by Seller after two consecutive years have elapsed without Buyer placing an order for the items which are manufactured using such property. Seller shall not be responsible for any loss or damage to such property while it is in Seller's possession or control.

10. Special Tooling. A tooling charge may be imposed for any special tooling, including without limitation, dies, fixtures, molds and patterns, acquired to manufacture Products. Such special tooling shall be and remain Seller's property notwithstanding payment of any charges by Buyer. In no event will Buyer acquire any interest in apparatus belonging to Seller which is utilized in the manufacture of the Products, even if such apparatus has been specially converted or adapted for such manufacture and notwithstanding any charges paid by Buyer. Unless otherwise agreed, Seller shall have the right to alter, discard or otherwise dispose of any special tooling or other property in its sole discretion at any time.

11. Buyer's Obligation; Rights of Seller. To secure payment of all sums due or otherwise, Seller shall retain a security interest in the goods delivered and this agreement shall be deemed a Security Agreement under the Uniform Commercial Code. Buyer authorizes Seller as its attorney to execute and file on Buyer's behalf all documents Seller deems necessary to perfect its security interest. Seller shall have a security interest in, and lien upon, any property of Buyer in Seller's possession as security for the payment of any amounts owed to Seller by Buyer.

12. Improper use and Indemnity. Buyer shall indemnify, defend, and hold Seller harmless from any claim, liability, damages, lawsuits, and costs (including attorney fees), whether for personal injury, property damage, patent, trademark or copyright infringement or any other claim, brought by or incurred by Buyer, Buyer's employees, or any other person, arising out of: (a) improper selection, improper application or other misuse of Products purchased by Buyer from Seller; (b) any act or omission, negligent or otherwise, of Buyer; (c) Seller's use of patterns, plans, drawings, or specifications furnished by Buyer to manufacture Product; or (d) Buyer's failure to comply with these terms and conditions. Seller shall not indemnify Buyer under any circumstance except as otherwise provided.

13. Cancellations and Changes. Orders shall not be subject to cancellation or change by Buyer for any reason, except with Seller's written consent and upon terms that will indemnify, defend and hold Seller harmless against all direct, incidental and consequential loss or damage. Seller may change product features, specifications, designs and availability with notice to Buyer.

14. Limitation on Assignment. Buyer may not assign its rights or obligations under this agreement without the prior written consent of Seller.

15. Entire Agreement. This agreement contains the entire agreement between the Buyer and Seller and constitutes the final, complete and exclusive expression of the terms of the agreement. All prior or contemporaneous written or oral agreements or negotiations with respect to the subject matter are herein merged.

16. Waiver and Severability. Failure to enforce any provision of this agreement will not waive that provision nor will any such failure prejudice Seller's right to enforce that provision in the future. Invalidation of any provision of this agreement by legislation or other rule of law shall not invalidate any other provision herein. The remaining provisions of this agreement will remain in full force and effect.

17. Termination. This agreement may be terminated by Seller for any reason and at any time by giving Buyer thirty (30) days written notice of termination. In addition, Seller may by written notice immediately terminate this agreement for the following: (a) Buyer commits a breach of any provision of this agreement (b) the appointment of a trustee, receiver or custodian for all or any part of Buyer's property (b) the filing of a petition for relief in bankruptcy of the other Party on its own behalf, or by a third party (c) an assignment for the benefit of creditors, or (d) the dissolution or liquidation of the Buyer.

18. Governing Law. This agreement and the sale and delivery of all Products hereunder shall be deemed to have taken place in and shall be governed and construed in accordance with the laws of the State of Ohio, as applicable to contracts executed and wholly performed therein and without regard to conflicts of laws principles. Buyer irrevocably agrees and consents to the exclusive jurisdiction and venue of the courts of Cuyahoga County, Ohio with respect to any dispute, controversy or claim arising out of or relating to this agreement. Disputes between the parties shall not be settled by arbitration unless, after a dispute has arisen, both parties expressly agree in writing to arbitrate the dispute.

19. Indemnity for Infringement of Intellectual Property Rights. Seller shall have no liability for infringement of any patents, trademarks, copyrights, trade dress, trade secrets or similar rights except as provided in this Section. Seller will defend and indemnify Buyer against allegations of infringement of U.S. patents, U.S. trademarks, copyrights, trade dress and trade secrets ("Intellectual Property Rights"). Seller will defend at its expense and will pay the cost of any settlement or damages awarded in an action brought against Buyer based on an allegation that a Product sold pursuant to this Agreement infringes the Intellectual Property Rights of a third party. Seller's obligation to defend and indemnify Buyer is contingent on Buyer notifying Seller within ten (10) days after Buyer becomes aware of such allegations of infringement, and Seller having sole control over the defense of any allegations or actions including all negotiations for settlement or compromise. If a Product is subject to a claim that it infringes the Intellectual Property Rights of a third party, Seller may, at its sole expense and option, procure for Buyer the right to continue using the Product, replace or modify the Product so as to make it noninfringing, or offer to accept return of the Product and return the purchase price less a reasonable allowance for depreciation. Notwithstanding the foregoing, Seller shall have no liability for claims of infringement based on information provided by Buyer, or directed to Products delivered hereunder for which the designs are specified in whole or part by Buyer, or infringements resulting from the modification, combination or use in a system of any Product sold hereunder. The foregoing provisions of this Section shall constitute Seller's sole and exclusive liability and Buyer's sole and exclusive remedy for infringement of Intellectual Property Rights.

20. Taxes. Unless otherwise indicated, all prices and charges are exclusive of excise, sales, use, property, occupational or like taxes which may be imposed by any taxing authority upon the manufacture, sale or delivery of Products.

21. Equal Opportunity Clause. For the performance of government contracts and where dollar value of the Products exceed \$10,000, the equal employment opportunity clauses in Executive Order 11246, VEVRAA, and 41 C.F.R. §§ 60-1.4(a), 60-741.5(a), and 60-250.4, are hereby incorporated.

G

