

# VF-71E Filter Housing Installation Instructions

## DESCRIPTION

The VF-71E Filter Housing is designed for use in industrial applications with a variety of oils and other liquids. The housing is shipped with no cartridge installed. Cartridges must be ordered separately.

CONNECTIONS SIZE: 3/4" NPT

HOUSING PRESSURE RATING: 150 psi

NOTE: FOR LIQUID SERVICE ONLY. Do not use or leak test this filter vessel with compressed air or other gasses.

## INSTALLATION

1. Install the housing in an area that provides access to the inlet, outlet, and drain fittings. Allow at least 18 inches of clearance above the band clamp for cartridge removal.
2. Make inlet and outlet connections to the appropriately labeled fittings. DO NOT flow backwards through the housing.
3. Installation of pressure gauges is recommended to monitor differential pressure across the housing and to allow accurate determination of when the filter cartridge should be changed. The auxiliary tap in the vessel lid can be used to install a gauge for measuring the pressure upstream. If the backpressure is expected to vary, it is recommended that gauges be installed upstream and downstream.
4. On systems where pressure can exceed 75 psi, a pressure bypass around the pump should be installed to protect the cartridge and the system from a high pressure shock of sudden cartridge seal-off due to a slug of water.
5. Installation of shut-off valves on the inlet and outlet lines may be required to isolate the housing during cartridge change-out.
6. Install the cartridge as outlined in the cartridge change-out section.
7. Write the proper cartridge model number on the enclosed replacement cartridge label, fasten it to the housing shell just below the VF-71E label, then cover the cartridge label with the enclosed clear plastic sticker.

## OPERATION

1. Check that all unused fittings on the vessel are plugged.
2. Open the top air vent and check that the bottom housing drain is closed.
3. Start the pump and verify that air is venting from the housing. IF NOT, TURN THE UNIT OFF; check all lines for obstructions.
4. Allow all air to vent from the housing. Close the top air vent when fluid begins to bleed out.
5. The vent should be opened periodically to expel any entrapped air. A large accumulation of air will reduce the filtering area of the cartridge.
6. Check all fittings and lid for leakage. Additional tightening may be required.
7. Note the pressure gauge reading. For most oils it will be below 5 psi with a clean cartridge.

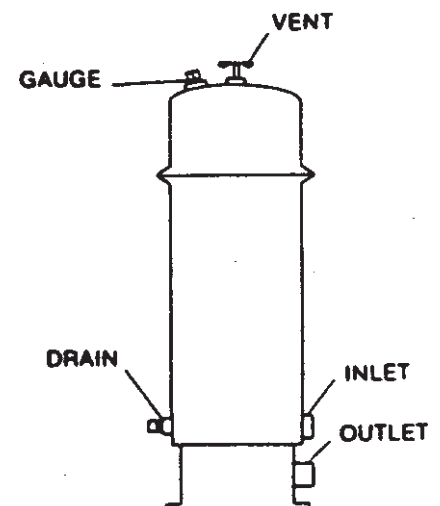

## CARTRIDGE CHANGE-OUT

1. When the pressure has risen by 20-25 psi over the initial clean pressure, or when differential pressure reaches 25 psid, the cartridge must be changed.
2. Turn the unit off.
3. Vent the housing at the cover, and drain all liquid through the bottom drain. **MAKE CERTAIN THE HOUSING IS COMPLETELY DRAINED BEFORE REMOVING THE LID.**
4. Loosen the band clamp and remove the lid.
5. Remove the old cartridge and install a new one. See the accompanying figure for proper assembly of parts. Use a new rubber washer included with each cartridge, and tighten the thumb screw until the rubber washer curls slightly.
6. Clean the cover o-ring and o-ring groove. Lightly lubricate the O-ring with the fuel or oil it will be used in, and position it on the groove (or head).
7. Replace the cover and fasten the band clamp.
8. Close the bottom drain and restart flow. Close the top air vent when the housing has filled.
9. Check all fittings and cover for leaks.

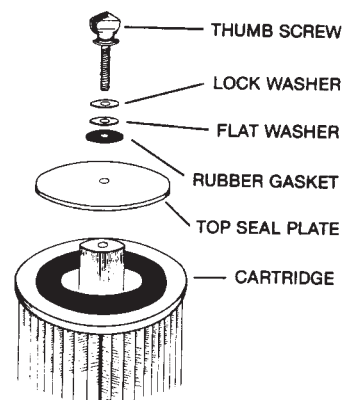

## REPLACEMENT PARTS

Description of Part	Velcon Part Number
Band Clamp Assembly	025X903
Air Vent	550X002
Top Seal Plate	12-02M
Rubber Gasket	G-0305
Flat Washer	402X046
Lock Washer	402X082
Thumb Screw	404X101
*Std. Buna-N Lid Gasket	G-1016
*Optional Viton A Lid Gasket	G-1016A

\*NOTE: Lid gaskets can be obtained at most O-ring suppliers. Specify size 2-442.

## CARTRIDGE SELECTION

TYPE	MODEL NUMBER	NOMINAL MICRON RATING	APPLICATION
PLEATED FILTER MEDIA	FO-718PLP3	0.3	For maximum particulate solids removal
	FO-718PL1/2	0.5	
	FO-718PL01	1	
	FO-718PL02	2	
	FO-718PL05	5	
	FO-718PL10	10	
	FO-718PL15	15	
	FO-718PL50	50	
PLEATED FILTER SYNTHETIC MEDIA	FOS-618PL1/2	0.5	Water resistant cartridge for particulate solids removal
	FOS-618PLP8	0.8	
	FOS-618PL05	5	
	FOS-718PL25	25	
FIBERGLASS DEPTH MEDIA	FO-618FGA5	5	Most cost effective for removal of colloidal contaminants
	FO-618FGA10	10	
	FO-618FGA25	25	
<b>Aquacon</b> ® PLEATED FILTER MEDIA and FREE WATER ABSORBENT MEDIA	AC-718P3	0.3	For both particulate solids and free water removal
	AC-7181/2	0.5	
	AC-71801	1	
	AC-71805	5	
FULLERS EARTH	LA-71801B	N/A	For removal of acids, gums, soaps, surfactants, corrosive gasses, polar compounds, oxidation products
ACTIVATED ALUMINA	LB-71801		
<b>Superdri</b> ® DISSOLVED WATER REMOVAL MEDIA	SD-718	N/A	For removal of dissolved water from insulating oils (max flow: 3 gpm)
	SD-718P3	0.3	