

RH Series Relief Valve



Spring Acquisition

The valve is shipped assembled complete less the adjustment cap and the lock nut. Springs can be acquired by ordering the appropriate kit. Spring kits are as follows:

Spring Pressure Range	Kit Name	Color Code
50-350 psi	KIT-RH4SP-50-350	Gray
350-750 psi	KIT-RH4SP-350-750	Red
750-1500 psi	KIT-RH4SP-750-1500	Orange
1500-2250 psi	KIT-RH4SP-1500-2250	Yellow
2250-3000 psi	KIT-RH4SP-2250-3000	Light Green
3000-4000 psi	KIT-RH4SP-3000-4000	Light Blue
4000-5000 psi	KIT-RH4SP-4000-5000	Burgundy
5000-6000 psi	KIT-RH4SP-5000-6000	Bright Yellow

Each kit includes a Spring, two (2) PTFE washers, a label, locking wire, and a lead tie down disk.

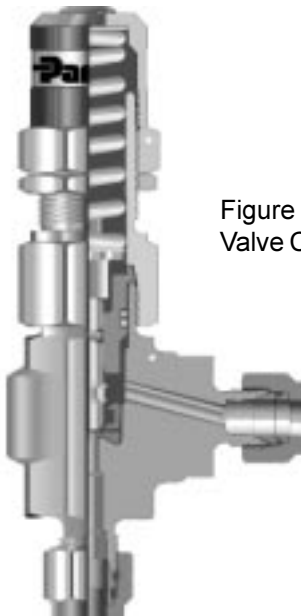

Figure 1: RH Series Relief Valve Cross Sectional View

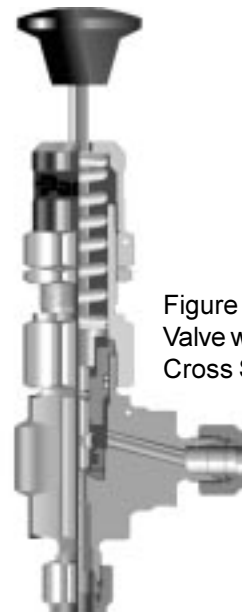

Figure 2: RH Series Relief Valve with Manual Override Cross Sectional View

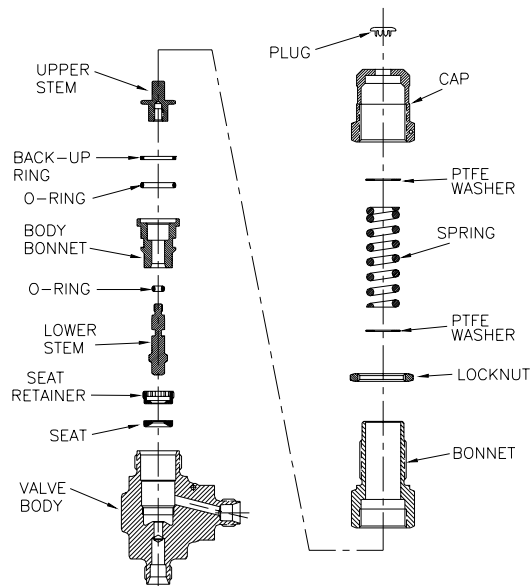

Figure 3: RH Series Relief Valve Exploded View

DISASSEMBLY

MAKE CERTAIN THE SYSTEM IN WHICH THE VALVE IS INSTALLED IS DRAINED AND/OR EXHAUSTED OF ALL PRESSURES BEFORE VALVE DISASSEMBLY OR REMOVAL OCCURS.

1. If the valve is locked into position, break apart the Locknut and Cap by turning the Locknut clockwise with a 7/8 inch wrench while holding the Cap with another 7/8 inch wrench.
2. If the valve is a manual version, loosen the Set Screw in the Handle by using a 5/64 hex Allen wrench and unthread the Handle from the Manual Upper Stem by holding the stem and rotating the Handle counter-clockwise.
3. Unthread the Cap from the Bonnet by rotating the Cap counter-clockwise.
4. Remove the Spring and PTFE Washers and set them aside for reuse during reassembly. (It is possibly easier to remove the lower PTFE washer after step 5.)
5. Remove the Bonnet from the Valve Body by turning counter-clockwise with a 7/8 inch wrench.
6. Using a pair of pliers, secure a grip onto the Upper Stem/Manual Upper Stem and pull the cartridge assembly from the Valve Body.
7. Disengage the Upper Stem/Manual Upper Stem and the Lower Stem by holding the Lower Stem with a pair of adjustable pliers (Do not clamp over the crimped o-ring if the stem is to be reused.) and unthreading the Upper Stem/Manual Upper Stem with a 7/16 inch wrench.
8. Remove the Lower Stem from the Body Bonnet by grasping the unthreaded end and gently pull it out.
9. Remove the Seat Retainer from the Valve Body by using a 5/16 inch allen wrench and turning counter-clockwise.
10. Gently remove the Seat from within the Valve Body.

REASSEMBLY

MAKE CERTAIN THAT ALL PARTS ARE FREE OF DIRT OR OTHER CONTAMINANTS BEFORE REASSEMBLY.

1. Using the appropriate mandrel, place the PTFE coated O-ring onto the Lower Stem. The mandrel fits over the threaded portion of the Lower Stem.
2. Using the appropriate mandrel, place the O-ring and Back-up ring onto the Body Bonnet. Be careful to insure proper orientation of the seals. Refer to Figure 1 or 2 for proper orientation.

3. Insert the Lower Stem into the Body Bonnet being careful not to damage the O-ring or Back-up Ring.
4. Thread the Upper Stem/ Manual Upper Stem onto the Lower Stem and torque to 12 in-lbs by gripping the Lower Stem with a pair of pliers and rotating the Upper Stem clockwise with a 7/16 inch hex socket torque wrench. (Do not clamp over the sealing surface of the Lower Stem.)
5. Insert the Seat into the Valve Body with its flat side up. Install the Seat Retainer into the Valve Body and torque to 5 in-lbs using a 5/16 inch allen wrench.
6. Insert the assembly from 4 into the Valve Body being careful not to damage the O-ring and Back-up Ring.
7. Apply a liberal amount of lubricant, as consistent with the Valve's service requirements, onto the body stem end threads.
8. Install the Bonnet onto the Valve Body and torque to 30 ft-lbs by turning clockwise with a 7/8 inch hex socket torque wrench.
9. Place a PTFE Washer into the bore of the Bonnet, insure that the washer is lying flat against the face of the Upper Stem.
10. Place the Spring into the bore of the Bonnet.
11. Place the other PTFE Washer onto the top of the Spring.
- NOTE:** If the valve is a Manual Version the a Manual Washer will be included. Insure that the vertical portion fits within the machined hole in the top to the Cap.
12. Place an appropriate lubricant, consistent with the valve's service requirements, on the internal threads of the Cap.
13. Thread the Cap onto the Bonnet. Insure that the washer remains atop the Spring during thread engagement.
14. If your system demands, lock the Cap in place by holding it with a 7/8 inch wrench and turning the Locknut counter-clockwise until it is snug against the Cap.
15. If the valve has a Manual Upper Stem, thread the Handle onto it.

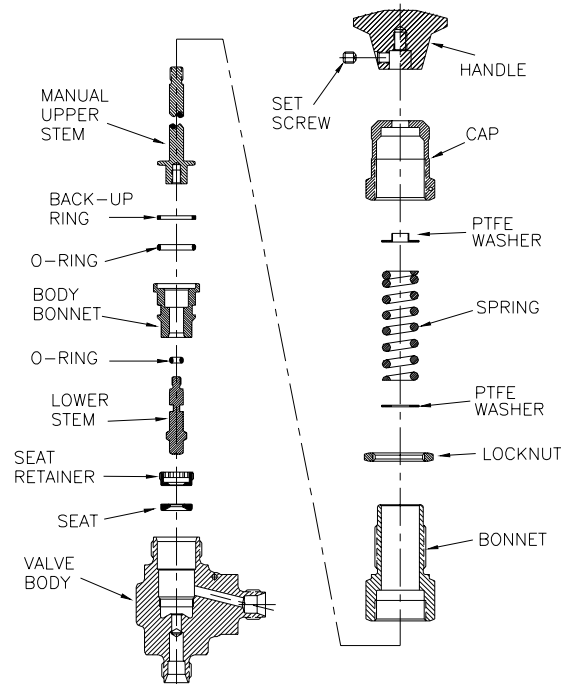

Figure 4: RH Series Relief Valve with Manual Override Exploded View

Setting Desired Cracking Pressure

1. Rotate the **Cap** to set the desired cracking pressure.
2. Tighten the **Lock Nut** against the **Cap**.
3. If required, secure the pressure setting by using the **Lockwire** to fasten the **Cap** and **Valve Body** together.

VALVE CONNECTOR MAKE-UP INSTRUCTIONS

MALE AND FEMALE PIPE PORTS

Wrench flats are provided on the Valve Body. It is recommended a smooth-jawed wrench or vise be used to grip the Valve Body.

1. On the male threaded part of the connection, apply a high quality pipe joint compound or PTFE tape made for this purpose. When PTFE tape is used, it is recommended two full turns of tape be applied. PTFE tape should not be overhanging or covering the first thread
2. Engage the Valve and the other component part together, until hand-tight.
3. With a proper wrench, holding both the Valve and the component part, continue to tighten to achieve a leak-tight joint.

ULTRASEAL CONNECTIONS

1. Insert the proper O-Ring into the UltraSeal fitting's O-Ring groove. Position the UltraSeal gland sealing face against the O-Ring, and then advance the Nut to a finger-tight position.
2. A positive seal is obtained by advancing the Nut no less than 1/4 turn from the finger-tight position. Proper UltraSeal make-up is achieved when a sharp rise in required application torque occurs, which indicates proper seal face contact and O-Ring seal compression into the UltraSeal groove.

VACUSEAL CONNECTIONS

1. A positive seal is obtained by advancing the Nut 1/8 turn from the finger-tight position.
2. A new gasket should be installed upon each fitting re-make to insure system pressure integrity.

TUBE FITTING CONNECTIONS

1. Insert the tube into the Valve port until the tube bottoms out in the Valve Body. Care should be exercised to insure the tube is properly aligned with the Valve Body and port.
2. Normal make-up for US Customary port sizes 1 thru 3 (1/16 thru 3/16 inch) and SI port sizes 2 thru 4 (2 thru 4 mm) is 3/4 turn from finger tight. Normal make-up for US Customary port sizes 4 thru 16 (1/4 thru 1 inch) and SI port sizes 5 thru 25 (5 thru 25 mm) is 1 1/4 turn from finger tight. For larger port sizes consult Parker Ferrule Presetting Tool Instructions.

PLEASE FOLLOW THE ABOVE DIRECTIONS FOR COUNTING THE NUMBER OF TURNS FOR PROPER FITTING MAKE-UP. DO NOT MAKE-UP TUBE FITTINGS BY TORQUE OR "FEEL". VARIABLES SUCH AS TUBING AND FITTING TOLERANCES, TUBE WALL THICKNESS, AND THE LUBRICITY OF NUT LUBRICANTS CAN RESULT IN AN IMPROPERLY ASSEMBLED TUBE FITTING CONNECTION.

A -Two ferrule A-LOK®
compression port



Z -Single ferrule CPI™
compression port



F -ANSI/ASME B1.20.1
Internal pipe threads



V -VacuSeal face
seal port



Q -UltraSeal face
seal port



M -ANSI/ASME B1.20.1
External pipe threads



WARNING

FAILURE OR IMPROPER SELECTION OR IMPROPER USE OF THE PRODUCTS AND/OR SYSTEMS DESCRIBED HEREIN OR RELATED ITEMS CAN CAUSE DEATH, PERSONAL INJURY AND PROPERTY DAMAGE.

This document and other information from Parker Hannifin Corporation, its subsidiaries and authorized distributors provide product and/or system options for further investigation by users having technical expertise. It is important that you analyze all aspects of your application and review the information concerning the product or system in the current product catalog. Due to the variety of operating conditions and applications for these products or systems, the user, through its own analysis and testing, is solely responsible for making the final selection of the products and systems and assuring that all performance, safety and warning requirements of the application are met.

The products described herein, including without limitation, product features, specifications, designs, availability and pricing, are subject to change by Parker Hannifin Corporation and its subsidiaries at any time without notice.

ALL PARKER VALVES MUST PASS A RIGID OPERATIONAL AND LEAKAGE TEST BEFORE LEAVING THE FACTORY. IT IS RECOMMENDED AFTER ANY REASSEMBLY, THE VALVE SHOULD BE TESTED BY THE USER FOR OPERATION AND LEAKAGE. IF THESE INSTRUCTIONS ARE NOT FULLY COMPLIED WITH, THE REPAIRED PRODUCT MAY FAIL AND CAUSE DAMAGE TO PROPERTY OR INJURY TO PERSONS. PARKER HANNIFIN CANNOT ASSUME RESPONSIBILITY FOR PERFORMANCE OF A CUSTOMER SERVICED VALVE.



MI-133 Revision -

Parker Hannifin Corporation
Instrumentation Valve Division
2651 Alabama Highway 21 North
Jacksonville, AL 36265-9681
USA
Phone: (256) 435-2130
Fax: (256) 435-7718
www.parker.com/IVD