

### NS Series Metering Valve



#### WORKING PRESSURES AND TEMPERATURES

Elastomer	Working Pressure	Temperature Range
Buna-N	2000 psig @ 70 °F 13.8 MPa @ 21 °C	-10 °F to 250 °F -23 °C to 121 °C
EPR		-40 °F to 250 °F -40 °C to 121 °C
Neoprene		-40 °F to 250 °F -40 °C to 121 °C
Fluorocarbon		-10 °F to 400 °F -23 °C to 204 °C

Always consult your authorized Parker representative if questions arise.

#### VALVE HANDLE ASSEMBLY AND DISASSEMBLY

**WARNING:** This valve is not field repairable for seat or seal damage. Removal of the Bonnet from the Valve Body may cause irreparable damage to the valve stem.



Figure 1: NS Series Metering Valve with Knurled Knob Cross Sectional View

## **KNURLED OR KNURLED SLOTTED HANDLE**

1. Close the valve by turning the handle clockwise until it reaches a positive stop against the top of the packing nut threads.
2. Remove the Knurled or Knurled Slotted Handle by loosening the set screw using a 1/16 inch allen wrench.

**WARNING: DO NOT TURN THE STEM WHILE THE HANDLE IS OFF THE VALVE.**

3. Place the Knurled or Knurled Slotted Handle onto the Valve Stem aligning the handle set screw with the valve stem flat.
4. Tighten the Handle Set Screw using a 1/16 inch allen wrench.

## **VERNIER HANDLE**

**NOTE:** The vernier handle assembly consists of a graduated collar, stem adapter, and the vernier handle.

1. Close the valve by turning the Vernier handle clockwise until the handle's zero reading aligns with the zero reading on the graduated collar.
2. Remove the vernier handle, stem adapter, and graduated collar by loosening the set screw with a 1/16 inch allen wrench.

**WARNING: DO NOT TURN THE STEM WHILE THE HANDLE IS OFF THE VALVE.**

1. Place the graduated collar onto the packing nut and butt it against the top of the packing nut threads. Orient the graduations for viewing ease and tighten the collar's set screw using a 1/16 inch allen wrench.
2. Place the stem adapter onto the valve stem, aligning the stem adapter's set screw with the valve stem flat. Position the stem adapter against the top of the packing nut. Tighten the set screw using a 1/16 inch hex wrench.  
**NOTE:** Correct positioning of the stem adapter is important as the stem adapter provides a positive stop ensuring against the over tightening and potential damage to the valve stem.
3. Position the vernier handle onto the stem adapter and align the zero reading on the graduated collar with the zero reading on the vernier handle. Tighten the set screw using a 1/16 inch allen wrench.

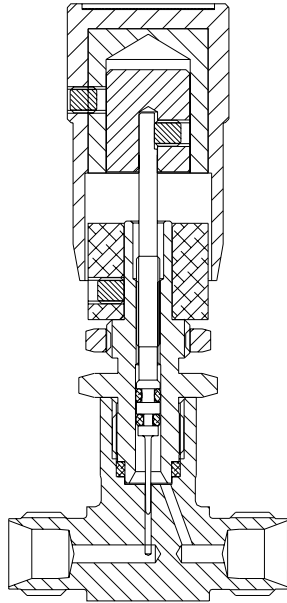

Figure 2: NS Series  
Metering Valve with Vernier  
Handle Cross Sectional  
View

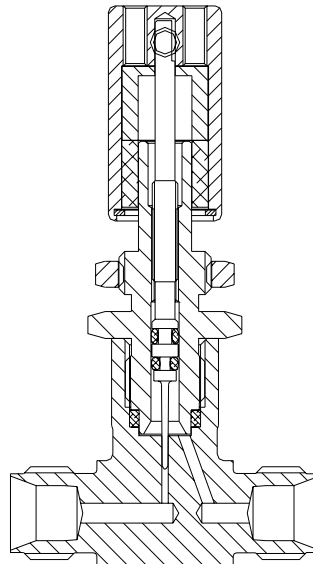

Figure 3: NS Series  
Metering Valve with  
Precision Adjustment  
Handle Cross Sectional  
View

### **PRECISION ADJUSTMENT HANDLE**

**NOTE:** The precision adjustment handle assembly consists of a precision adjustment handle, a handle set screw, and two (2) torque adjustment set screws.

1. Close the valve by turning the handle clockwise until it reaches a positive stop against the top of the packing nut threads.
2. Loosen the torque adjustment (in applicable) using a .050 inch allen wrench and the handle set screw using a 1/16 inch allen wrench and remove the handle assembly.

**WARNING: DO NOT TURN THE STEM WHILE THE HANDLE IS OFF THE VALVE.**

3. Place the precision adjustment handle assembly onto the valve stem, aligning the handle set screw with the valve stem flat. Position the handle against the top of the packing nut threads.
4. Tighten the handle set screw using a 1/16 inch allen wrench.

**NOTE:** Correct positioning of the handle is important as it provides a positive stop ensuring against the over tightening and potential damage to the valve stem. Tighten the torque adjustment set screws to give the desired handle torque.

## RETROFIT INSTRUCTIONS KNURLED HANDLE TO VERNIER HANDLE

The Vernier Handle Assembly Kit consist of a Graduated Collar, Stem Adapter, Set Screws, and the Vernier Handle.

### Required Tools

1/32 inch Hex Wrench (for the Knurled Handle Lock Set Screw)

1/16 inch Hex Wrench (for the Vernier Handle, Graduated Collar, and Stem Adapter Set Screws)

1. If tightened, use a 1/32 inch hex wrench and loosen the Knurled Handle lock screw. Use a 1/16 inch hex wrench and loosen the Knurled Handle set screw. Remove the Knurled Handle from the valve assembly. If the valve is to be panel mounted, mount the valve prior to assembly of the Vernier Handle. Refer to IN-238 for panel mounting procedures.
2. Place the Graduated Collar onto the Packing Nut and butt it against the top of the Packing Nut threads. Orient the graduations for viewing ease and tighten the collar's set screw.
3. Place the Stem Adapter onto the valve stem, aligning the Stem Adapter's set screw with the Valve Stem flat or drill point, and tighten the set screw. Using the Stem Adapter as a valve handle, close the valve. Correct positioning of the Stem Adapter is important as the Stem Adapter provides a positive stop to prevent potential damage.
4. Position the Vernier Handle onto the Stem Adapter and align the zero reading on the Graduated Collar with the zero reading on the Vernier Handle. Tighten the set screw and the retrofit is complete.

## RETROFIT INSTRUCTIONS KNURLED HANDLE TO PRECISION HANDLE

The Precision Handle Assembly Kit consist of a Precision Adjustment Handle, a Handle Set Screw, and two Torque Adjustment Set Screws.

### Required Tools

1/16 inch Hex Wrench (for the Handle Set Screw)

1/16 inch Hex Wrench (for the Torque Adjustment Set Screws)

1. Turn the Knurled Handle clockwise until it reaches a positive stop against the top of the Packing Nut threads. The valve is now in the closed position (as determined during assembly and testing at the factory). **NOTE: Do not turn the valve stem until the remaining steps are completed.**
2. Loosen the Torque Adjustment and Handle Set Screws and remove the Knurled Handle assembly. Remove the Panel Nut. If the valve is to be panel mounted, mount the valve prior to assembly of the Precision Handle. Refer to IN-238 for panel mounting procedures.
3. Place the Precision Adjustment assembly onto the Valve Stem, aligning the Handle Set Screw with the Valve Stem flat. Position the Precision Handle against the top of the Packing Nut threads. Tighten the Handle Set Screw. Correct positioning of the Handle is important as the Handle provides a positive stop to prevent potential damage. Tighten the Torque Adjustment Set Screws to provide the desired handle operating torque. The Precision Adjustment Handle retrofit is complete.

## VALVE CONNECTOR MAKE-UP INSTRUCTIONS

### MALE AND FEMALE PIPE PORTS

Wrench flats are provided on the Valve Body. It is recommended a smooth-jawed wrench or vise be used to grip the Valve Body.

1. On the male threaded part of the connection, apply a high quality pipe joint compound or PTFE tape made for this purpose. When PTFE tape is used, it is recommended two full turns of tape be applied. PTFE tape should not be overhanging or covering the first thread
2. Engage the Valve and the other component part together, until hand-tight.
3. With a proper wrench, holding both the Valve and the component part, continue to tighten to achieve a leak-tight joint.

### ULTRASEAL CONNECTIONS

1. Insert the proper O-Ring into the UltraSeal fitting's O-Ring groove. Position the UltraSeal gland sealing face against the O-Ring, and then advance the Nut to a finger-tight position.
2. A positive seal is obtained by advancing the Nut no less than 1/4 turn from the finger-tight position. Proper UltraSeal make-up is achieved when a sharp rise in required application torque occurs, which indicates proper seal face contact and O-Ring seal compression into the UltraSeal groove.

### VACUSEAL CONNECTIONS

1. A positive seal is obtained by advancing the Nut 1/8 turn from the finger-tight position.
2. A new gasket should be installed upon each fitting re-make to insure system pressure integrity.

### TUBE FITTING CONNECTIONS

1. Insert the tube into the Valve port until the tube bottoms out in the Valve Body. Care should be exercised to insure the tube is properly aligned with the Valve Body and port.
2. Normal make-up for US Customary port sizes 1 thru 3 (1/16 thru 3/16 inch) and SI port sizes 2 thru 4 (2 thru 4 mm) is 3/4 turn from finger tight. Normal make-up for US Customary port sizes 4 thru 16 (1/4 thru 1 inch) and SI port sizes 5 thru 25 (5 thru 25 mm) is 1 1/4 turn from finger tight. For larger port sizes consult Parker Ferrule Presetting Tool Instructions.

**PLEASE FOLLOW THE ABOVE DIRECTIONS FOR COUNTING THE NUMBER OF TURNS FOR PROPER FITTING MAKE-UP. DO NOT MAKE-UP TUBE FITTINGS BY TORQUE OR "FEEL". VARIABLES SUCH AS TUBING AND FITTING TOLERANCES, TUBE WALL THICKNESS, AND THE LUBRICITY OF NUT LUBRICANTS CAN RESULT IN AN IMPROPERLY ASSEMBLED TUBE FITTING CONNECTION.**

**A** -Two ferrule A-LOK®  
compression port



**Z** -Single ferrule CPI™  
compression port



**F** -ANSI/ASME B1.20.1  
Internal pipe threads

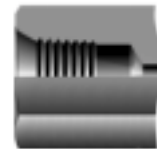

**V** -VacuSeal face  
seal port



**Q** -UltraSeal face  
seal port



**M** -ANSI/ASME B1.20.1  
External pipe threads



---

## WARNING

**FAILURE OR IMPROPER SELECTION OR IMPROPER USE OF THE PRODUCTS AND/OR SYSTEMS DESCRIBED HEREIN OR RELATED ITEMS CAN CAUSE DEATH, PERSONAL INJURY AND PROPERTY DAMAGE.**

This document and other information from Parker Hannifin Corporation, its subsidiaries and authorized distributors provide product and/or system options for further investigation by users having technical expertise. It is important that you analyze all aspects of your application and review the information concerning the product or system in the current product catalog. Due to the variety of operating conditions and applications for these products or systems, the user, through its own analysis and testing, is solely responsible for making the final selection of the products and systems and assuring that all performance, safety and warning requirements of the application are met.

The products described herein, including without limitation, product features, specifications, designs, availability and pricing, are subject to change by Parker Hannifin Corporation and its subsidiaries at any time without notice.

**ALL PARKER VALVES MUST PASS A RIGID OPERATIONAL AND LEAKAGE TEST BEFORE LEAVING THE FACTORY. IT IS RECOMMENDED AFTER ANY REASSEMBLY, THE VALVE SHOULD BE TESTED BY THE USER FOR OPERATION AND LEAKAGE. IF THESE INSTRUCTIONS ARE NOT FULLY COMPLIED WITH, THE REPAIRED PRODUCT MAY FAIL AND CAUSE DAMAGE TO PROPERTY OR INJURY TO PERSONS. PARKER HANNIFIN CANNOT ASSUME RESPONSIBILITY FOR PERFORMANCE OF A CUSTOMER SERVICED VALVE.**



MI-138 Revision -

**Parker Hannifin Corporation**  
Instrumentation Valve Division  
2651 Alabama Highway 21 North  
Jacksonville, AL 36265-9681  
USA  
Phone: (256) 435-2130  
Fax: (256) 435-7718  
[www.parker.com/IVD](http://www.parker.com/IVD)