



Moduflex Valve System

**Instant Control For All
Pneumatic Actuators**

**Modular Valve Islands or
Stand-Alone Valves**

Catalog 0655-4/USA



Global Pneumatics, Warning, Offer of Sale

**Global
Pneumatics**

This icon can be found next to products that are widely supported by Parker Pneumatics' worldwide manufacturing and sales network. When you see this icon, you can be confident that this product is manufactured and / or stocked* worldwide for rapid delivery. In addition to local manufacturing or inventory, our sales network has been specifically trained on these products to provide our customers with the best possible service.

Products not showing this icon are still sold and distributed worldwide. However, The Global Pneumatics icon represents products that customers can expect the best level of support.

If you are a multi-national company, seek global sourcing or ship globally, depend on Parker Pneumatic for **PREMIER CUSTOMER SERVICE**.

* Stocking levels vary by country

WARNING

FAILURE OR IMPROPER SELECTION OR IMPROPER USE OF THE PRODUCTS AND/OR SYSTEMS DESCRIBED HEREIN OR RELATED ITEMS CAN CAUSE DEATH, PERSONAL INJURY AND PROPERTY DAMAGE.

This document and other information from Parker Hannifin Corporation, its subsidiaries and authorized distributors provide product and/or system options for further investigation by users having technical expertise. It is important that you analyze all aspects of your application including consequences of any failure, and review the information concerning the product or system in the current product catalog. Due to the variety of operating conditions and applications for these products or systems, the user, through its own analysis and testing, is solely responsible for making the final selection of the products and systems and assuring that all performance, safety and warning requirements of the application are met.

The products described herein, including without limitation, product features, specifications, designs, availability and pricing, are subject to change by Parker Hannifin Corporation and its subsidiaries at any time without notice.

Offer of Sale

The items described in this document are hereby offered for sale by Parker Hannifin Corporation, its subsidiaries or its authorized distributors. This offer and its acceptance are governed by the provisions stated on the separate page of this document entitled "Offer of Sale".

Index

Model Selection & Assembly.....	2-3
Basic Valve Functions	4-5
S Series	
Size 1 Ordering Guide	6-7
Size 2 Ordering Guide	8-9
Model Number Index	10
Assemblies & Components.....	11
T Series	
Size 1 Ordering Guide	12-13
Size 2 Ordering Guide	14-15
Model Number Index	16
Assemblies & Components.....	17
V Series	
Size 1 Ordering Guide	18-19
Size 2 Ordering Guide	20-21
Model Number Index	22
Assemblies & Components.....	23
Wiring & Addressing	24-25
Field Bus Connection Modules.....	26
Technical Information, Device Bus Modules.....	27-30
Moduflex Configurations.....	31-34
Technical Information, Device Bus Modules.....	35-37
P Series	
Pressure Regulators	38-39
Check Valve Module	40
Dual Flow Control	41
Model Number Index	42
Assemblies & Components.....	43-45
Intermediate Supply Module Model Number Index.....	46
Internal / External Pilot Technical Information.....	47
Moduflex Island Assembly Model Number Index	48
V Series Assemblies & Components	49
Maintenance Procedure	50
Maintenance Components	51
Specifications	52
Dimensions.....	53-59
Valve Island Configurator CD-ROM.....	60-61
Safety Guide.....	62-63
Offer of Sale	65

Bold text part numbers are standard.

Standard text part numbers may have longer lead times.





Module Series Selection and Assembly Procedures

Moduflex system provides a complete choice of either stand-alone valves, short-build valve islands, or large valve island configurations. Electrical control connections may be individual or island integrated. Peripheral modules add complementary functions — flow control, pressure regulation, P.O. check valves and vacuum generators can be added directly to the valve or used as a stand alone product.

Moduflex gives machine builders maximum flexibility to assemble each automation system step by step using basic modules.

Valve islands can be easily assembled using the following procedure.

1. Assemble the required valve island with the basic modules.
2. Mount the valve island on the machine together with any stand-alone valves and peripheral modules.
3. Select and install the required clip-on pneumatic and electrical connectors.

“S” Series Stand Alone Valves

For isolated cylinders on a machine, it is preferable to locate the valve close by. Therefore a stand-alone module is ideal. Response time and air consumption are then reduced to a minimum. Peripheral modules can be installed directly into the valve.



“S” Series Size 1 Single Solenoid



“S” Series Size 1 Single Air Pilot



Straight or Elbow Pneumatic Connectors



Union Pneumatic Connectors

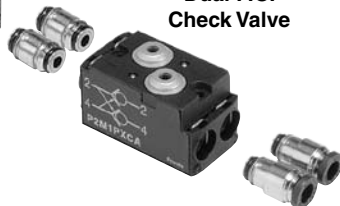

Dual P.O. Check Valve

“T” Series Valve Island Modules with Individual Connectors

For small groups of cylinders requiring short localized valve islands, it is convenient to use individual electrical connector islands.



“T” Series Island Modules

“T” Series modules are easily assembled to form a complete manifold. All electrical connectors are individual and pneumatic connectors are of the push-in tube type. Modules with different functions and flow passages may be combined in the same island manifold, giving total flexibility to adapt to all machine requirements.

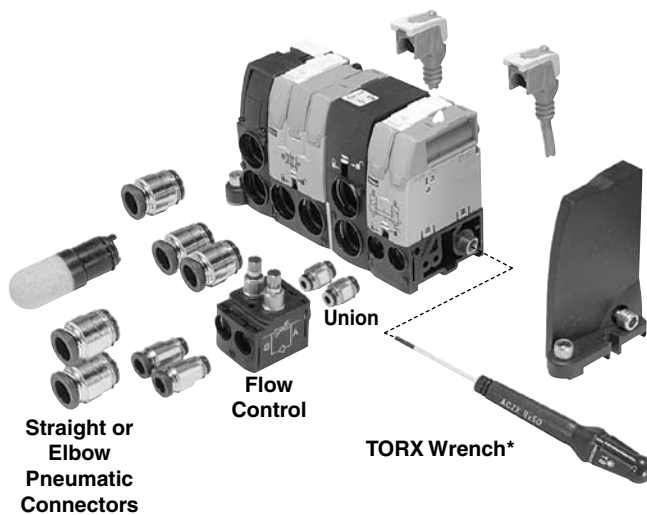

* Maximum torque rating 10.6 in. lbs. (1.2 Nm).



"V" Series Valve Island Modules with Integrated Connections

When the number of valves is larger, modular islands are easily assembled using the integrated electrical connection series. These islands are then connected to the control PLC, with a multi-connector cable or with a field bus connection.



"V" Series with 20-Pin Connector



"V" Series with Field Bus Connection

"V" Series modules are easily assembled to form a complete manifold. All pneumatic connectors are of the push-in tube type. When the valve island has been installed, it is a simple operation to separate the field bus module from the valve island using the quick release lever. Modules with different functions and flow passages may be combined in the same island manifold, giving total flexibility to adapt to all machine requirements.

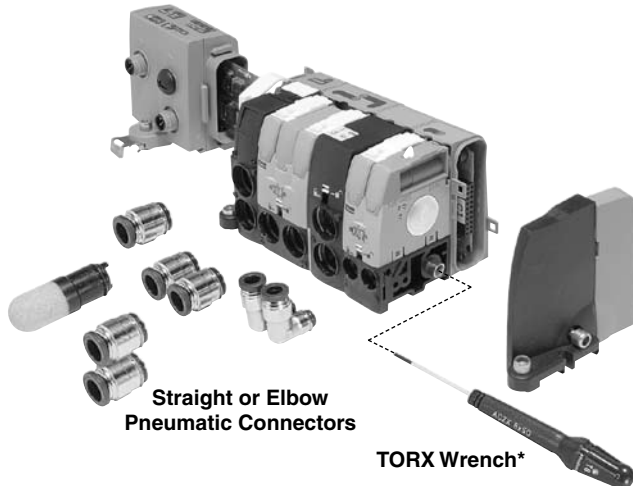

Straight or Elbow
 Pneumatic Connectors

TORX Wrench*

* Maximum torque rating 10.6 in. lbs. (1.2 Nm).

"P" Series Peripheral Modules

Peripheral Modules are available and can be mounted directly to valves or used as a stand alone product. These modules answer the complementary needs of the cylinders, flow controls, pressure regulation or positioning.



Flow Control



Pressure Regulator



Dual P.O.
 Check Valve



Pressure Sensor



Vacuum Generator



Valve Function

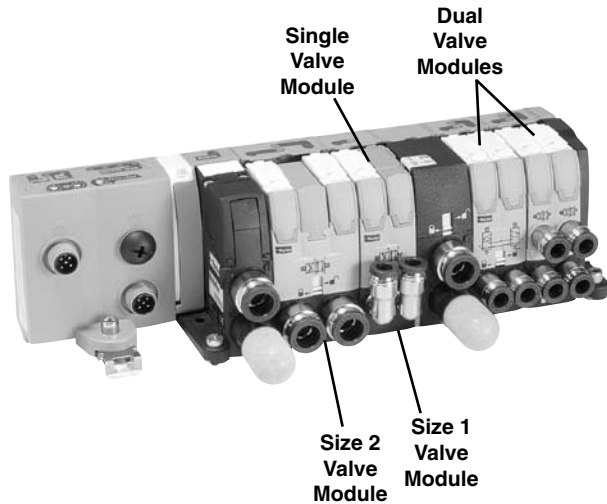

Moduflex Valve Islands offer the greatest flexibility for your design requirements.

Valve Modules are available as 4-Way or 3-Way valves and can be ordered as single or dual valves. A Single Valve Module has one valve in one valve body. A Dual Valve Module will have 2 valves in one valve body. Each Valve in the Dual Valve Body is controlled by a solenoid or air pilot and can be operated independently from the other valve in the same body. There are no dimensional difference between a single and a dual valve. Flow Rates are reduced on the dual valves.



Single valve modules offer Ceramic Slide Valve Technology while dual valve modules offer WCS – Wear Compensation System Technology. Both offer low friction shift forces, fast response and less spool wear.

Valve Modules are available in two different valve body sizes. Size 1 and Size 2 Valve Modules can be combined in both “T” and “V” Series Valve Islands without transition kits.

4/2 , 4 Way, 2 Position Valves

Single Valves	ANSI Symbol	Description	Size 1 Body	Size 2 Body
		Single Solenoid, Spring Return Valve	Cv = .32	Cv = .80
		Single Air Pilot, Spring Return Valve		
		Double Solenoid Valve	Cv = .32	Cv = .80
		Double Air Pilot Valve		
Dual Valves	ANSI Symbol	Description	Size 1 Body	Size 2 Body
		(2) Single Solenoid, Spring Return Valve with Exhaust Check. Double Solenoid Valve Body	Cv = .18	N/A
		(2) Single Air Pilot, Spring Return Valve with Exhaust Check. Double Air Pilot Valve Body		

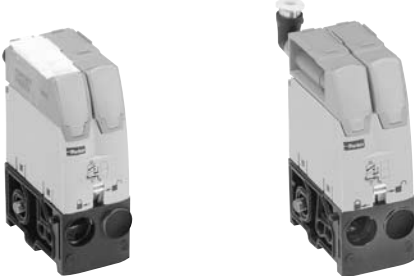
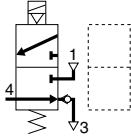
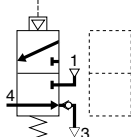
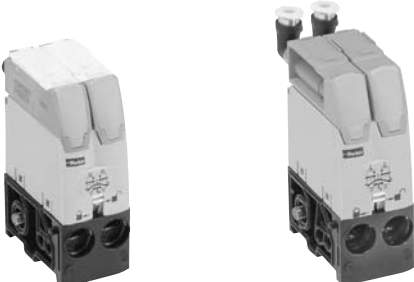
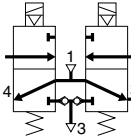
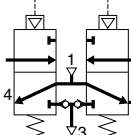
3/2 , 3 Way, 2 Position Valves

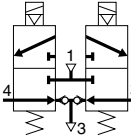
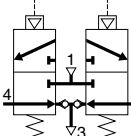
Single Valves	ANSI Symbol	Description	Size 1 Body	Size 2 Body
		Single Solenoid, NC, Spring Return Valve with Exhaust Check.	Cv = .22	Cv = .44
		Single Air Pilot, NC, Spring Return Valve with Exhaust Check.		
Dual Valves	ANSI Symbol	Description	Size 1 Body	Size 2 Body
		(2) Single Solenoid, NO, Spring Return Valve with Exhaust Check. Double Solenoid Valve Body	Cv = .22	Cv = .44
		(2) Single Air Pilot, NO, Spring Return Valve with Exhaust Check. Double Air Pilot Valve Body		
		(2) Single Solenoid, NC, Spring Return Valve with Exhaust Check. Double Solenoid Valve Body	Cv = .22	Cv = .44
		(2) Single Air Pilot, NC, Spring Return Valve with Exhaust Check. Double Air Pilot Valve Body		

Dual 3/2 Valves Replace All 3-Position Valves for a Better Performance

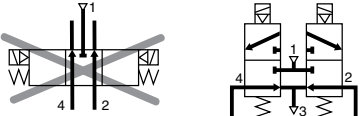
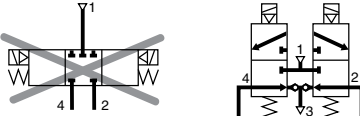
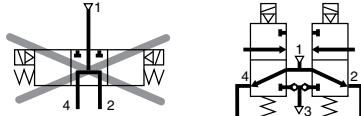
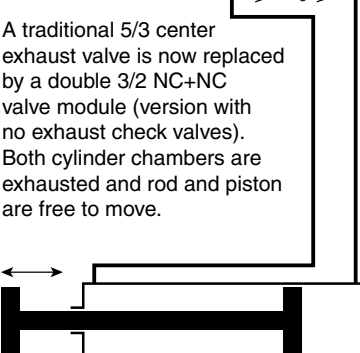
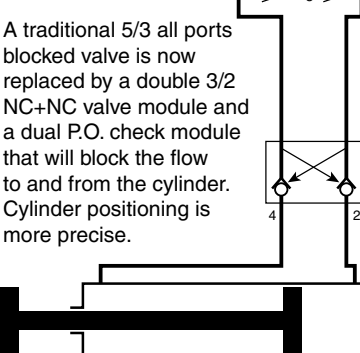
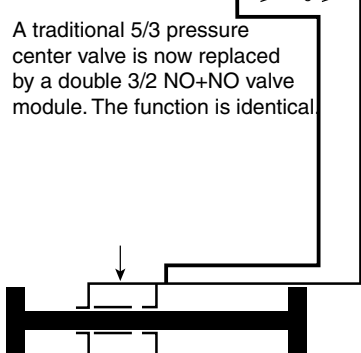
<p>3-Position Center Exhaust</p> 	<p>3-Position All Ports Blocked</p> 	<p>3-Position Pressure Center</p> 
<p>A traditional 5/3 center exhaust valve is now replaced by a double 3/2 NC+NC valve module (version with no exhaust check valves). Both cylinder chambers are exhausted and rod and piston are free to move.</p> 	<p>A traditional 5/3 all ports blocked valve is now replaced by a double 3/2 NC+NC valve module and a dual P.O. check module that will block the flow to and from the cylinder. Cylinder positioning is more precise.</p> 	<p>A traditional 5/3 pressure center valve is now replaced by a double 3/2 NO+NO valve module. The function is identical.</p> 



“S” Series Basic Modules Size 1
(Without Pneumatic Connectors)



Single Solenoid



Double Solenoid



Single Air Pilot



Double Air Pilot

Size 1 Electro-Pneumatic
Stand Alone Valve Modules, 24VDC

4-Way / 2-Position / Single Valve

	Solenoid	Weight	Part Number
	Single Solenoid (Monostable)	2.54 oz	P2M1S4ES2C
	Double Solenoid (Bistable)	3.07 oz	P2M1S4EE2C

Size 1 Air Pilot
Stand Alone Valve Modules

4-Way / 2-Position / Single Valve

	Solenoid	Weight	Part Number
	Single Air Pilot (Monostable)	2.54 oz	P2M1S4PS
	Double Air Pilot (Bistable)	3.07 oz	P2M1S4PP

3-Way / 2-Position / Dual Valve

	Solenoid	Weight	Part Number
	Double Solenoid NC + NC with Exhaust Check	3.00 oz	P2M1SDEE2C
	Double Solenoid NO + NO with Exhaust Check	3.00 oz	P2M1SCEE2C
	Double Solenoid NC + NO with Exhaust Check	3.00 oz	P2M1SEEE2C
	Single Solenoid NC with Exhaust Check	2.82 oz	P2M1S3ES2C
	Center Exhaust = dual 3/2 NC + NC without Exhaust Check	3.00 oz	P2M1SGEE2C

3-Way / 2-Position / Dual Valve

	Solenoid	Weight	Part Number
	Double Air Pilot NC + NC with Exhaust Check	2.82 oz	P2M1TDPP
	Double Air Pilot NO + NO with Exhaust Check	2.82 oz	P2M1TCPP
	Single Air Pilot NC	2.68 oz	P2M1T3PS

Note: Includes 5/32" (4mm) Air Pilot Connectors.

Note: Bold Options Standard





M8 Female Individual Connectors with Flying Lead Cable (For Solenoid Pilots)



With LED Voltage Surge Protection and Flying Lead Cable IP67 Protected		Weight (oz)	Order Code
	2 m Cable	2.19	P8LS08L226C
	5 m Cable	5.47	P8LS08L526C
	9 m Cable	9.88	P8LS08L926C

Pneumatic Connectors for Size 1 Modules



		Elbow Version		Straight Version	
		Weight (oz)	Order Code	Weight (oz)	Order Code
Tube Push-in Connector	5/32" = 4mm OD	0.18	CMD04-1	0.07	FMD04-1
	6mm OD	0.18	CMD06-1	0.11	FMD06-1
	1/4" OD	0.18	CMD07-1B	0.11	FMD07-1B
Muffler for Exhaust Port	—	—	—	0.11	MMDVA1
Plug	—	—	—	0.18	PMDYY1
Double Male Union (For Peripheral Valve Modules)	—	—	—	0.21	HMDXX1

Note: 85 Durometer minimum for pneumatic connectors.



“S” Series Basic Modules Size 2
(Without Pneumatic Connectors)



Single Solenoid



Double Solenoid



Single Air Pilot



Double Air Pilot

Size 2 Electro-Pneumatic
Stand Alone Valve Modules, 24VDC

4-Way / 2-Position / Single Valve

	Solenoid	Weight	Part Number
	Single Solenoid (Monostable)	2.75 oz	P2M2S4ES2C
	Double Solenoid (Bistable)	3.28 oz	P2M2S4EE2C

Size 2 Air Pilot
Stand Alone Valve Modules

4-Way / 2-Position / Single Valve

	Solenoid	Weight	Part Number
	Single Air Pilot (Monostable)	2.75 oz	P2M2S4PS
	Double Air Pilot (Bistable)	3.28 oz	P2M2S4PP

3-Way / 2-Position / Dual Valve

	Solenoid	Weight	Part Number
	Double Solenoid NC + NC with Exhaust Check	3.53 oz	P2M2SDEE2C
	Double Solenoid NO + NO with Exhaust Check	3.53 oz	P2M2SCEE2C
	Double Solenoid NC + NO with Exhaust Check	3.53 oz	P2M2SEEE2C
	Single Solenoid NC with Exhaust Check	3.35 oz	P2M2S3ES2C
	Center Exhaust = dual 3/2 NC + NC without Exhaust Check	3.53 oz	P2M2SGEE2C

3-Way / 2-Position / Dual Valve

	Solenoid	Weight	Part Number
	Double Air Pilot NC + NC with Exhaust Check	3.53 oz	P2M2SDPP
	Double Air Pilot NO + NO with Exhaust Check	3.53 oz	P2M2SCPP
	Single Air Pilot NC with Exhaust Check	3.35 oz	P2M2S3PS

Note: Includes 5/32" (4mm) Air Pilot Connectors.

Note: Bold Options Standard



M8 Female Individual Connectors with Flying Lead Cable (For Solenoid Pilots)



With LED Voltage Surge Protection and Flying Lead Cable IP67 Protected		Weight (oz)	Order Code
	2 m Cable	2.19	P8LS08L226C
	5 m Cable	5.47	P8LS08L526C
	9 m Cable	9.88	P8LS08L926C

Pneumatic Connectors for Size 2 Modules



		Elbow Version		Straight Version	
		Weight (oz)	Order Code	Weight (oz)	Order Code
Tube Push-in Connector	6mm OD	0.18	CMD06-2	0.11	FMD06-2
	1/4" OD	0.18	CMD07-2B	0.11	FMD07-2B
	8mm OD	0.21	CMD08-2	0.14	FMD08-2
	3/8" OD	0.21	CMD09-2B	0.14	FMD09-2B
	10mm OD	0.25	CMD10-2	0.18	FMD10-2
	12mm OD	0.28	CMD12-2	0.21	FMD12-2
	1/2" OD	—	—	0.21	FMD13-2B
Muffler for Exhaust Port	—	—	—	0.11	MMDVA2
Plug	—	—	—	0.18	PMDYY2
Double Male Union (For Peripheral Valve Modules)	—	—	—	0.28	HMDXX2

Note: 85 Durometer minimum for pneumatic connectors.



"S" Series Stand-alone Valve Modules Model Number Index
Complete Modules (Complete with Pneumatic and Electrical Connectors)

Basic Series P2M	Size 1	Valve Series S	Valve Type / Function 4ES	Operator Voltage 2C	LED / Cable 00	Fitting Configuration A	Ports (All Ports) F4
Basic Series P2M Moduflex	Size 1 Size 1 2 Size 2	Valve Series S Stand Alone	Valve Type / Function 3-Way / 2 Position 3ES Single Solenoid, NC Spring Return 3PS Single Air Pilot, NC Spring Return 4-Way / 2 Position 4ES Single Solenoid, Spring Return 4PS Single Air Pilot, Spring Return 4EE Double Solenoid 4PP Double Air Pilot Dual 3-Way, 2 Position, Spring Return BEE* Solenoid, NC / NC + PO check (4/3 APB) BPP* Air Pilot, NC / NC + PO check (4/3 APB) CEE Solenoid, NO / NO (4/3 Press. Ctr.) CPP Air Pilot, NO / NO (4/3 Press. Ctr.) DEE Solenoid, NC / NC with Exhaust Check DPP Air Pilot, NC / NC with Exhaust Check EEE Solenoid, NO / NC with Exhaust Check GEE Solenoid, NC / NC without Check (4/3 Exh.Ctr.)	Operator Voltage 2C 24VDC 00 Remote Air Pilot-5/32" (4mm) Tube	LED / Cable 00 No Cable, No LED, No Surge Suppression V2 2 Meter Cable with LED and Surge Suppression V5 5 Meter Cable with LED and Surge Suppression V9 9 Meter Cable with LED and Surge Suppression	Fitting Configuration A* Straight Fittings B* Elbow Fittings C† Straight Fitting & Muffler D* Elbow Fitting & Muffler * Ports 1 & 3 fittings sizes are same as Ports 2 & 4 (See example below) † Fitting in Port 1, Muffler in Port 3	Ports (All Ports) C0* 10mm Elbow Fitting C2* 12mm Elbow Fitting C4 5/32" (4mm) Elbow Fitting C6 6mm Elbow Fitting C7 1/4" Elbow Fitting C8* 8mm Elbow Fitting C9* 3/8" Elbow Fitting F0* 10mm Straight Fitting F2* 12mm Straight Fitting F3* 1/2" Straight Fitting F4 5/32" (4mm) Straight Fitting F6 6mm Straight Fitting F7 1/4" Straight Fitting F8* 8mm Straight Fitting F9* 3/8" Straight Fitting

EXAMPLE for Fitting Configuration:

Size 1

CF7 Ports 1 & 3
1/4" Straight Fitting & Muffler
Ports 2 & 4
1/4" Straight Fittings

Size 2

AC0 Ports 1 & 3
10mm Elbow Fittings
Ports 2 & 4
10mm Elbow Fittings

* Valve includes peripheral P. O. Check Valve and union fittings.

Note: Bold Options Standard

With Only One Universal Solenoid Pilot for all Configurations

24VDC is now a global standard for all machines.

The Moduflex 24VDC unique solenoid pilot is supplied with the multi-function manual override that can be adapted to all requirements, as explained by the drawings.

Multi-Function Adaptable Manual Override

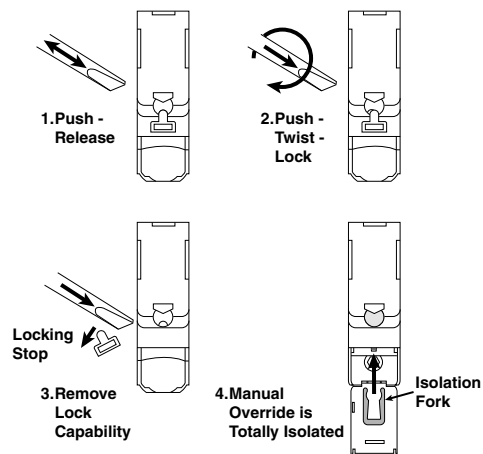



“S” Series Single Solenoid

Example:

Size 1, 4-Way Single Solenoid valve with 1/4" Straight Connectors in Ports 1, 2 and 4. Exhaust Muffler in Port 3. Valve to include 2m cable with LED and surge suppression.

How to Order Complete Valve Assembly

Line Item	Quantity	Part Number	Description
1	1	P2M1S4ES2CV2CF7	Size 1, Stand Alone Valve Module, 4 Way, Single Solenoid, 2m Cable with LED / Surge Suppression, Exhaust Muffler with 1/4" OD Straight Port Fittings

Notes:

1. Cables supplied loose with valve.
2. For LED and Surge Suppressor, cable must be supplied with valve.

How to Order Components

Line Item	Quantity	Part Number	Description
1	1	P2M1S4ES2C	Size 1, Stand Alone Valve Module, Single Solenoid, 4 Way
2	1	P8LS08L226C	2m Cable with LED / Surge Suppression
3	3	FMD07-1B	Size 1, 1/4" OD Tube Push In Connector
4	1	MMDVA1	Size 1, Muffler for Exhaust Port



“T” Series Basic Modules Size 1
(Without Pneumatic Connectors)



Single Solenoid



Double Solenoid



Single Air Pilot



Double Air Pilot

Size 1 Electro-Pneumatic
Island Valve Modules, 24VDC

4-Way / 2-Position / Single Valve

	Solenoid	Weight	Part Number
	Single Solenoid (Monostable)	2.40 oz	P2M1T4ES2C
	Double Solenoid (Bistable)	2.72 oz	P2M1T4EE2C

4-Way / 2-Position / Dual Valve

	Solenoid	Weight	Part Number
	Solenoid Spring with Exhaust Check	2.72 oz	P2M1TJEE2C

3-Way / 2-Position / Dual Valve

	Solenoid	Weight	Part Number
	Double Solenoid NC + NC with Exhaust Check	2.82 oz	P2M1TDEE2C
	Double Solenoid NO + NO with Exhaust Check	2.82 oz	P2M1TCEE2C
	Double Solenoid NC + NO with Exhaust Check	2.82 oz	P2M1TEEE2C
	Single Solenoid NC with Exhaust Check	2.68 oz	P2M1T3ES2C
	Center Exhaust = dual 3/2 NC + NC without Exhaust Check	2.84 oz	P2M1TGEE2C

Size 1 Air Pilot
Island Valve Modules

4-Way / 2-Position / Single Valve

	Solenoid	Weight	Part Number
	Single Air Pilot (Monostable)	2.40 oz	P2M1T4PS
	Double Air Pilot (Bistable)	2.72 oz	P2M1T4PP

4-Way / 2-Position / Dual Valve

	Solenoid	Weight	Part Number
	Air Pilot Spring with Exhaust Check	2.72 oz	P2M1TJPP

3-Way / 2-Position / Dual Valve

	Solenoid	Weight	Part Number
	Double Air Pilot NC + NC with Exhaust Check	2.82 oz	P2M1TDPP
	Double Air Pilot NO + NO with Exhaust Check	2.82 oz	P2M1TCPP
	Single Air Pilot NC with Exhaust Check	2.68 oz	P2M1T3PS

Note: Includes 5/32" (4mm) Air Pilot Connectors.

Note: Bold Options Standard



M8 Female Individual Connectors with Flying Lead Cable (For Solenoid Pilots)



With LED Voltage Surge Protection and Flying Lead Cable IP67 Protected		Weight (oz)	Order Code
	2 m Cable	2.19	P8LS08L226C
	5 m Cable	5.47	P8LS08L526C
	9 m Cable	9.88	P8LS08L926C

Pneumatic Connectors for Size 1 Modules



		Elbow Version		Straight Version	
		Weight (oz)	Order Code	Weight (oz)	Order Code
Tube Push-in Connector	5/32" = 4mm OD	0.18	CMD04-1	0.07	FMD04-1
	6mm OD	0.18	CMD06-1	0.11	FMD06-1
	1/4" OD	0.18	CMD07-1B	0.11	FMD07-1B
Muffler for Exhaust Port	—	—	—	0.11	MMDVA2
Plug	—	—	—	0.18	PMDYY1
Double Male Union (For Peripheral Valve Modules)	—	—	—	0.21	HMDXX1

Note: 85 Durometer minimum for pneumatic connectors.



P2M1K0TASD



P2M2HXT01

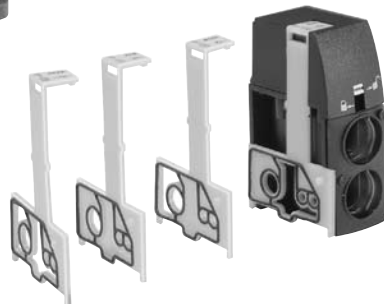

P2M2BXT0A

Island Modules

Module	Weight (oz)	Order Code
Pneumatic Head and Tail Set	2.26	P2M2HXT01*
Pneumatic Head and Tail Set with TORX Screwdriver	2.50	P2M2HXT0T*
TORX Screwdriver Only	.24	P2M1K0TAFD
Intermediate Supply Module (With a set of 4 Configuration Plates)	1.48	P2M2BXT0A*

* Use Fittings for Size 2 Modules Only.



**“T” Series Basic Modules Size 2
 (Without Pneumatic Connectors)**



Single Solenoid



Double Solenoid



Single Air Pilot



Double Air Pilot

**Size 2 Electro-Pneumatic
 Island Valve Modules, 24VDC**

4-Way / 2-Position / Single Valve

	Solenoid	Weight	Part Number
	Single Solenoid (Monostable)	2.61 oz	P2M2T4ES2C
	Double Solenoid (Bistable)	2.93 oz	P2M2T4EE2C

**Size 2 Air Pilot
 Island Valve Modules**

4-Way / 2-Position / Single Valve

	Solenoid	Weight	Part Number
	Single Air Pilot (Monostable)	2.61 oz	P2M2T4PS
	Double Air Pilot (Bistable)	2.93 oz	P2M2T4PP

3-Way / 2-Position / Dual Valve

	Solenoid	Weight	Part Number
	Double Solenoid NC + NC with Exhaust Check	3.32 oz	P2M2TDEE2C
	Double Solenoid NO + NO with Exhaust Check	3.32 oz	P2M2TC EE2C
	Double Solenoid NC + NO with Exhaust Check	3.32 oz	P2M2TE EE2C
	Single Solenoid NC with Exhaust Check	3.17 oz	P2M2T3ES2C
	Center Exhaust = dual 3/2 NC + NC without Exhaust Check	3.32 oz	P2M2TGEE2C

3-Way / 2-Position / Dual Valve

	Solenoid	Weight	Part Number
	Double Air Pilot NC + NC with Exhaust Check	3.32 oz	P2M2TD PP
	Double Air Pilot NO + NO with Exhaust Check	3.32 oz	P2M2TC PP
	Single Air Pilot NC with Exhaust Check	2.61 oz	P2M2T3 PS

Note: Includes 5/32" (4mm) Air Pilot Connectors.

Note: Bold Options Standard





M8 Female Individual Connectors with Flying Lead Cable (For Solenoid Pilots)



With LED Voltage Surge Protection and Flying Lead Cable IP67 Protected		Weight (oz)	Order Code
	2 m Cable	2.19	P8LS08L226C
	5 m Cable	5.47	P8LS08L526C
	9 m Cable	9.88	P8LS08L926C

Pneumatic Connectors for Size 2 Modules



		Elbow Version		Straight Version	
		Weight (oz)	Order Code	Weight (oz)	Order Code
Tube Push-in Connector	6mm OD	0.18	CMD06-2	0.11	FMD06-2
	1/4" OD	0.18	CMD07-2B	0.11	FMD07-2B
	8mm OD	0.21	CMD08-2	0.14	FMD08-2
	3/8" OD	0.21	CMD09-2B	0.14	FMD09-2B
	10mm OD	0.25	CMD10-2	0.18	FMD10-2
	12mm OD	0.28	CMD12-2	0.21	FMD12-2
	1/2" OD	—	—	0.21	FMD13-2B
Muffler for Exhaust Port	—	—	—	0.11	MMDVA2
Plug	—	—	—	0.18	PMDYY2
Double Male Union (For Peripheral Valve Modules)	—	—	—	0.28	HMDXX2

Note: 85 Durometer minimum for pneumatic connectors.



P2M1K0TASD



P2M2HXT01

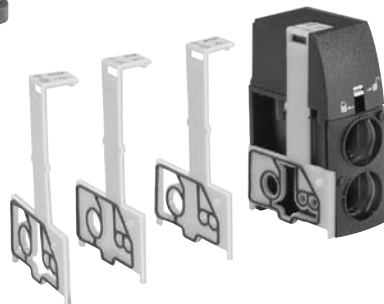

P2M2BXT0A

Island Modules

Module	Weight (oz)	Order Code
Pneumatic Head and Tail Set	2.26	P2M2HXT01*
Pneumatic Head and Tail Set with TORX Screwdriver	2.50	P2M2HXT0T*
TORX Screwdriver Only	.24	P2M1K0TAFD
Intermediate Supply Module (With a set of 4 Configuration Plates)	1.48	P2M2BXT0A*

* Use Fittings for Size 2 Modules Only.



"T" Series Island Valve Modules Model Number Index
Complete Modules (Complete with Pneumatic and Electrical Connectors)

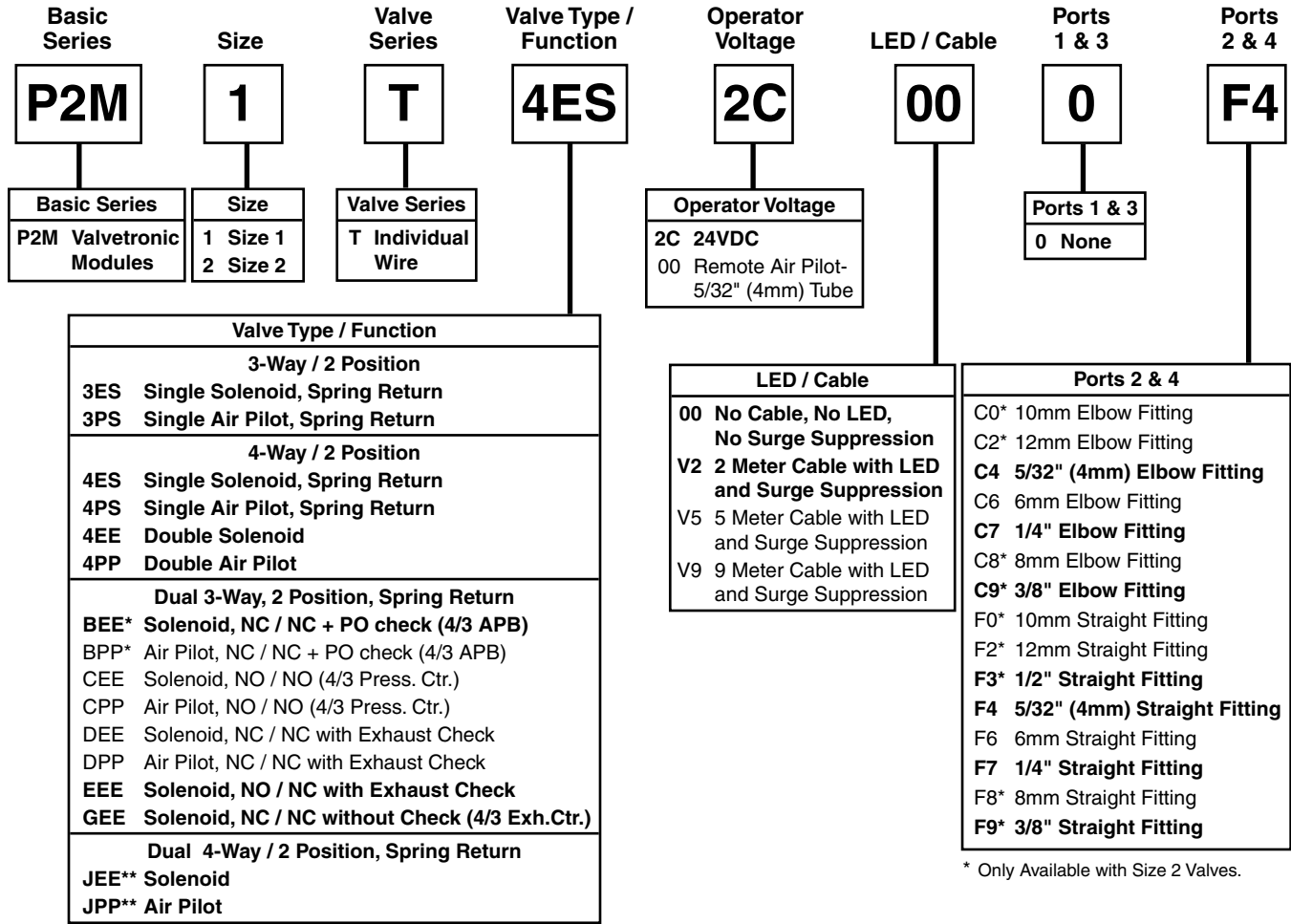

* Only Available with Size 2 Valves.

* Valve includes peripheral P. O. Check Valve and union fittings.

** Size 1 Only.

Note: Bold Options Standard

With Only One Universal Solenoid Pilot for all Configurations

24VDC is now a global standard for all machines.

The Moduflex 24VDC unique solenoid pilot is supplied with the multi-function manual override that can be adapted to all requirements, as explained by the drawings.

Multi-Function Adaptable Manual Override

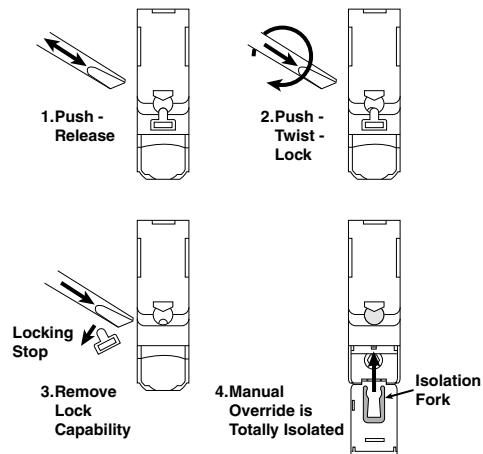



“T” Series Single Solenoid

Example:

Size 1, 4-Way Single Solenoid valve with 1/4" Straight Connectors in Ports 2 and 4. Valve to include 2m cable with LED and surge suppression.

How to Order Complete Valve Assembly

Line Item	Quantity	Part Number	Description
1	1	P2M1T4ES2CV20F7	Size 1, T Series Island Valve Module, 4 Way, Single Solenoid, 2m Cable with LED / Surge Suppression, 1/4" OD Straight Port Fittings

Notes:

1. Cables supplied loose with valve.
2. For LED and Surge Suppressor, cable must be supplied with valve.
3. To assemble into a manifold, Pneumatic Head and Tail Set must be ordered separately.

How to Order Components

Line Item	Quantity	Part Number	Description
1	1	P2M1T4ES2C	Size 1, T Series Island Valve Module, Single Solenoid, 4 Way
2	1	P8LS08L226C	2m Cable with LED / Surge Suppression
3	2	FMD07-1B	Size 1, 1/4" OD Tube Push In Connector



“V” Series Basic Modules Size 1
(Without Pneumatic Connectors)



Single Solenoid



Double Solenoid

Size 1 Electro-Pneumatic
Island Valve Modules, 24VDC

4-Way / 2-Position / Single Valve

	Solenoid	Weight	Part Number
	Single Solenoid (Monostable)	3.32 oz	P2M1V4ES2CV
	Double Solenoid (Bistable)	3.63 oz	P2M1V4EE2CV

4-Way / 2-Position / Dual Valve

	Solenoid	Weight	Part Number
	Solenoid Spring with Exhaust Check	3.63 oz	P2M1VJEE2CV

3-Way / 2-Position / Dual Valve

	Solenoid	Weight	Part Number
	Double Solenoid NC + NC with Exhaust Check	3.74 oz	P2M1VDEE2CV
	Double Solenoid NO + NO with Exhaust Check	3.74 oz	P2M1VCEE2CV
	Double Solenoid NC + NO with Exhaust Check	3.74 oz	P2M1VEEE2CV
	Single Solenoid NC with Exhaust Check	3.60 oz	P2M1V3ES2CV
	Center Exhaust = dual 3/2 NC + NC without Exhaust Check	3.74 oz	P2M1VGEE2CV

Pneumatic Connectors
for Size 1 Modules



		Elbow Version		Straight Version	
		Weight (oz)	Order Code	Weight (oz)	Order Code
Tube Push-in Connector	5/32" = 4mm OD	0.18	CMD04-1	0.07	FMD04-1
	6mm OD	0.18	CMD06-1	0.11	FMD06-1
	1/4" OD	0.18	CMD07-1B	0.11	FMD07-1B
Muffler for Exhaust Port	—	—	—	0.11	MMDVA2
Plug	—	—	—	0.18	PMDYY1
Double Male Union (For Peripheral Valve Modules)	—	—	—	0.21	HMDXX1

Note: 85 Durometer minimum for pneumatic connectors.

Note: Bold Options Standard



P2M2HEV0A



P2M2HEV0D



Electrical 20-Pin Multi-Connector with Flying Lead Cable

Electrical Connector

Module	Weight (oz)	Order Code
20-Pin, Multi-Connector Electrical Head Module	1.34	P2M2HEV0A
25-Pin, D-Sub, Electrical Head Module	1.34	P2M2HEV0D

Cable Length	Weight (oz)	Order Code
2 m	10.97	P8LMH20M2A
5 m	27.41	P8LMH20M5A
9 m	49.38	P8LMH20M9A



P2M1K0TASD



P2M2HXT01



P2M2BXV0A



Electrical 25-Pin D-Sub Cable (IP40)

Cable Length	Weight (oz)	Order Code
3 m	14.3	P8LMH25M3A

Island Modules

Module	Weight (oz)	Order Code
Pneumatic Head and Tail Set	2.26	P2M2HXT01*
Pneumatic Head and Tail Set with TORX Screwdriver	2.50	P2M2HXT0T*
TORX Screwdriver Only	.24	P2M1K0TAFD
Intermediate Supply Module (With a set of 4 Configuration Plates)	1.48	P2M2BXT0A*

* Use Fittings for Size 2 Modules Only.



**“V” Series Basic Modules Size 2
 (Without Pneumatic Connectors)**



Single Solenoid



Double Solenoid

**Size 2 Electro-Pneumatic
 Island Valve Modules, 24VDC**

4-Way / 2-Position / Single Valve

	Solenoid	Weight	Part Number
	Single Solenoid (Monostable)	3.53 oz	P2M2V4ES2CV
	Double Solenoid (Bistable)	3.88 oz	P2M2V4EE2CV

3-Way / 2-Position / Dual Valve

	Solenoid	Weight	Part Number
	Double Solenoid NC + NC with Exhaust Check	4.06 oz	P2M2VDEE2CV
	Double Solenoid NO + NO with Exhaust Check	4.06 oz	P2M2VCEE2CV
	Double Solenoid NC + NO with Exhaust Check	4.06 oz	P2M2VEEE2CV
	Single Solenoid NC with Exhaust Check	3.88 oz	P2M2V3ES2CV
	Center Exhaust = dual 3/2 NC + NC without Exhaust Check	4.06 oz	P2M2VGEE2CV

**Pneumatic Connectors
 for Size 2 Modules**



PMDYY2



MMDVA2



HMDXX2



FMD09-2



CMD13-2

		Elbow Version		Straight Version	
		Weight (oz)	Order Code	Weight (oz)	Order Code
Tube Push-in Connector	6mm OD	0.18	CMD06-2	0.11	FMD06-2
	1/4" OD	0.18	CMD07-2B	0.11	FMD07-2B
	8mm OD	0.21	CMD08-2	0.14	FMD08-2
	3/8" OD	0.21	CMD09-2B	0.14	FMD09-2B
	10mm OD	0.25	CMD10-2	0.18	FMD10-2
	12mm OD	0.28	CMD12-2	0.21	FMD12-2
	1/2" OD	—	—	0.21	FMD13-2B
Muffler for Exhaust Port	—	—	—	0.11	MMDVA2
Plug	—	—	—	0.18	PMDYY2
Double Male Union (For Peripheral Valve Modules)	—	—	—	0.28	HMDXX2

Note: 85 Durometer minimum for pneumatic connectors.

Note: Bold Options Standard



P2M2HEV0A



P2M2HEV0D



Electrical 20-Pin Multi-Connector with Flying Lead Cable

Electrical Connector

Module	Weight (oz)	Order Code
20-Pin, Multi-Connector Electrical Head Module	1.34	P2M2HEV0A
25-Pin, D-Sub, Electrical Head Module	1.34	P2M2HEV0D

Cable Length	Weight (oz)	Order Code
2 m	10.97	P8LMH20M2A
5 m	27.41	P8LMH20M5A
9 m	49.38	P8LMH20M9A



P2M1K0TASD



P2M2HXT01



P2M2BXV0A



Electrical 25-Pin D-Sub Cable (IP40)

Cable Length	Weight (oz)	Order Code
3 m	14.3	P8LMH25M3A

Island Modules

Module	Weight (oz)	Order Code
Pneumatic Head and Tail Set	2.26	P2M2HXT01*
Pneumatic Head and Tail Set with TORX Screwdriver	2.50	P2M2HXT0T*
TORX Screwdriver Only	.24	P2M1K0TAFD
Intermediate Supply Module (With a set of 4 Configuration Plates)	1.48	P2M2BXT0A*

* Use Fittings for Size 2 Modules Only.



“V” Series Island Valve Modules Model Number Index
Complete Modules (Complete with Pneumatic and Electrical Connectors)

Basic Series P2M	Size 1	Valve Series V	Function 4ES	Operator Voltage 2C	LED / Cable 00	Ports 1 & 3 0	Ports 2 & 4 F7																																														
Basic Series P2M Valvetronic Modules	Size 1 Size 1 2 Size 2	Valve Series V Valvetronic		Voltage 2C 24VDC		Ports 1 & 3 0 None																																															
<table border="1"> <tr><th colspan="2">Valve Type / Function</th></tr> <tr><td colspan="2">3-Way / 2 Position</td></tr> <tr><td>3ES</td><td>Single Solenoid, NC, Spring Return</td></tr> <tr><td colspan="2">4-Way / 2 Position</td></tr> <tr><td>4ES</td><td>Single Solenoid, Spring Return</td></tr> <tr><td>4EE</td><td>Double Solenoid</td></tr> <tr><td colspan="2">Dual 3-Way, 2 Position, Spring Return</td></tr> <tr><td>BEE*</td><td>Solenoid, NC / NC + PO check (4/3 APB)</td></tr> <tr><td>CEE*</td><td>Solenoid, NO / NO (4/3 Press. Ctr.)</td></tr> <tr><td>DEE</td><td>Solenoid, NC / NC with Exhaust Check</td></tr> <tr><td>EEE</td><td>Solenoid, NO / NC with Exhaust Check</td></tr> <tr><td>GEE</td><td>Solenoid, NC / NC without Check (4/3 Exh.Ctr.)</td></tr> <tr><td colspan="2">Dual 4-Way, 2 Position, Spring Return</td></tr> <tr><td>JEE**</td><td>Solenoid</td></tr> </table>			Valve Type / Function		3-Way / 2 Position		3ES	Single Solenoid, NC, Spring Return	4-Way / 2 Position		4ES	Single Solenoid, Spring Return	4EE	Double Solenoid	Dual 3-Way, 2 Position, Spring Return		BEE*	Solenoid, NC / NC + PO check (4/3 APB)	CEE*	Solenoid, NO / NO (4/3 Press. Ctr.)	DEE	Solenoid, NC / NC with Exhaust Check	EEE	Solenoid, NO / NC with Exhaust Check	GEE	Solenoid, NC / NC without Check (4/3 Exh.Ctr.)	Dual 4-Way, 2 Position, Spring Return		JEE**	Solenoid	<table border="1"> <tr><th>LED / Cable</th></tr> <tr><td>V0 No Cable, with LED and Surge Suppression</td></tr> </table>		LED / Cable	V0 No Cable, with LED and Surge Suppression	<table border="1"> <tr><th>Ports 2 & 4</th></tr> <tr><td>C0* 10mm Elbow Fitting</td></tr> <tr><td>C2* 12mm Elbow Fitting</td></tr> <tr><td>C4 5/32" (4mm) Elbow Fitting</td></tr> <tr><td>C6 6mm Elbow Fitting</td></tr> <tr><td>C7 1/4" Elbow Fitting</td></tr> <tr><td>C8* 8mm Elbow Fitting</td></tr> <tr><td>C9* 3/8" Elbow Fitting</td></tr> <tr><td>F0* 10mm Straight Fitting</td></tr> <tr><td>F2* 12mm Straight Fitting</td></tr> <tr><td>F3* 1/2" Straight Fitting</td></tr> <tr><td>F4 5/32" (4mm) Straight Fitting</td></tr> <tr><td>F6 6mm Straight Fitting</td></tr> <tr><td>F7 1/4" Straight Fitting</td></tr> <tr><td>F8* 8mm Straight Fitting</td></tr> <tr><td>F9* 3/8" Straight Fitting</td></tr> </table>			Ports 2 & 4	C0* 10mm Elbow Fitting	C2* 12mm Elbow Fitting	C4 5/32" (4mm) Elbow Fitting	C6 6mm Elbow Fitting	C7 1/4" Elbow Fitting	C8* 8mm Elbow Fitting	C9* 3/8" Elbow Fitting	F0* 10mm Straight Fitting	F2* 12mm Straight Fitting	F3* 1/2" Straight Fitting	F4 5/32" (4mm) Straight Fitting	F6 6mm Straight Fitting	F7 1/4" Straight Fitting	F8* 8mm Straight Fitting	F9* 3/8" Straight Fitting
Valve Type / Function																																																					
3-Way / 2 Position																																																					
3ES	Single Solenoid, NC, Spring Return																																																				
4-Way / 2 Position																																																					
4ES	Single Solenoid, Spring Return																																																				
4EE	Double Solenoid																																																				
Dual 3-Way, 2 Position, Spring Return																																																					
BEE*	Solenoid, NC / NC + PO check (4/3 APB)																																																				
CEE*	Solenoid, NO / NO (4/3 Press. Ctr.)																																																				
DEE	Solenoid, NC / NC with Exhaust Check																																																				
EEE	Solenoid, NO / NC with Exhaust Check																																																				
GEE	Solenoid, NC / NC without Check (4/3 Exh.Ctr.)																																																				
Dual 4-Way, 2 Position, Spring Return																																																					
JEE**	Solenoid																																																				
LED / Cable																																																					
V0 No Cable, with LED and Surge Suppression																																																					
Ports 2 & 4																																																					
C0* 10mm Elbow Fitting																																																					
C2* 12mm Elbow Fitting																																																					
C4 5/32" (4mm) Elbow Fitting																																																					
C6 6mm Elbow Fitting																																																					
C7 1/4" Elbow Fitting																																																					
C8* 8mm Elbow Fitting																																																					
C9* 3/8" Elbow Fitting																																																					
F0* 10mm Straight Fitting																																																					
F2* 12mm Straight Fitting																																																					
F3* 1/2" Straight Fitting																																																					
F4 5/32" (4mm) Straight Fitting																																																					
F6 6mm Straight Fitting																																																					
F7 1/4" Straight Fitting																																																					
F8* 8mm Straight Fitting																																																					
F9* 3/8" Straight Fitting																																																					

* Valve includes peripheral P. O. Check Valve and union fittings.
 ** Size 1 Only.

* Only Available with Size 2 Valves.

Note: Bold Options Standard

With Only One Universal Solenoid Pilot for all Configurations

24VDC is now a global standard for all machines.

The Moduflex 24VDC unique solenoid pilot is supplied with the multi-function manual override that can be adapted to all requirements, as explained by the drawings.

Multi-Function Adaptable Manual Override

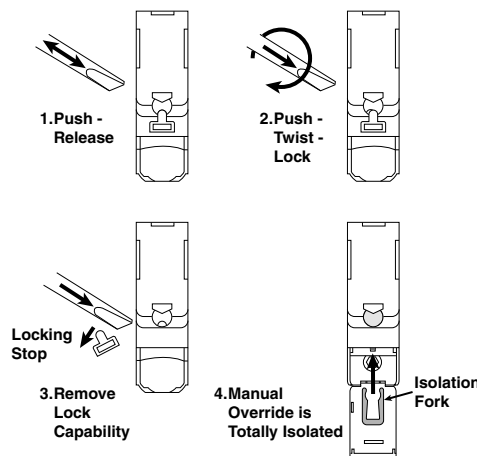



Example:

Size 1, 4-Way Single Solenoid valve with 1/4" Straight Connectors in Ports 2 and 4. Valve to include LED and surge suppression.



“V” Series Single Solenoid

How to Order Complete Valve Assembly

Line Item	Quantity	Part Number	Description
1	1	P2M2V4ES2CV00F7	Size 1, V Series Island Valve Module, 4 Way, Single Solenoid, LED / Surge Suppression, 1/4" OD Straight Port Fittings

Notes:

1. LED and Surge Suppressor included with valve.
2. To assemble into a manifold, Pneumatic Head and Tail Set and Electrical Connector must be ordered separately.

How to Order Components

Line Item	Quantity	Part Number	Description
1	1	P2M1V4ES2CV	Size 1, V Series Island Valve Module, Single Solenoid, 4 Way
2	2	FMD07-1B	Size 1, 1/4" OD Tube Push In Connector



“V” Series 25-Pin, D-Sub Addressing



Valve Island Head 25-Pin, Multi-Connector

On the island head module, the multi-connector integrates the HE10 connector standard in its 25-Pin version.

Its plug-in function is secured in position with a guillotine lock with easy access from the front of the island.

The 25-Pin, D-Sub multi-connector is rated for IP40.

25-Pin, Multi-Connector Addressing

When assembling a **V Series** island, modules are automatically connected to the head module through the modular principle of the integrated electrical connections.

Each wire color code corresponds a solenoid pilot position in the island.

Electrical 25-Pin D-Sub Cable (IP40)

Cable Length	Weight (oz)	Order Code
3 m	14.3	P8LMH25M3A

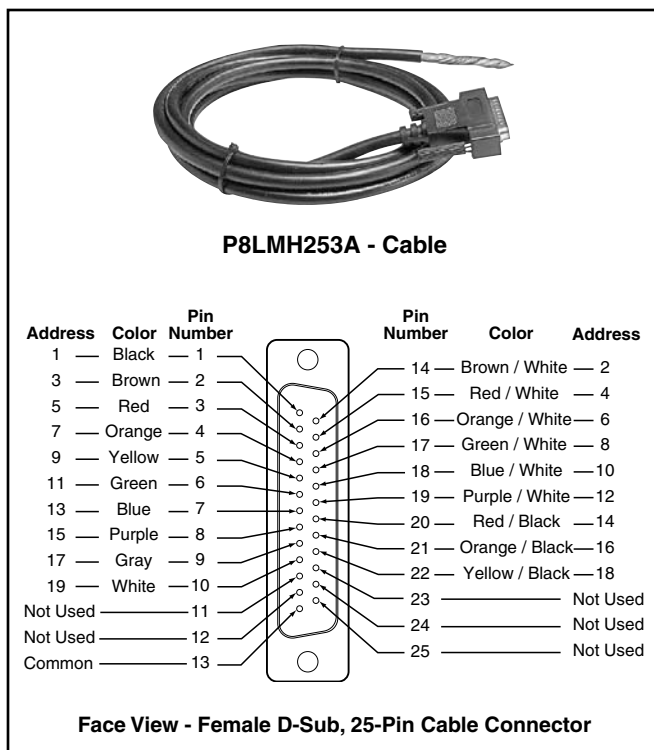
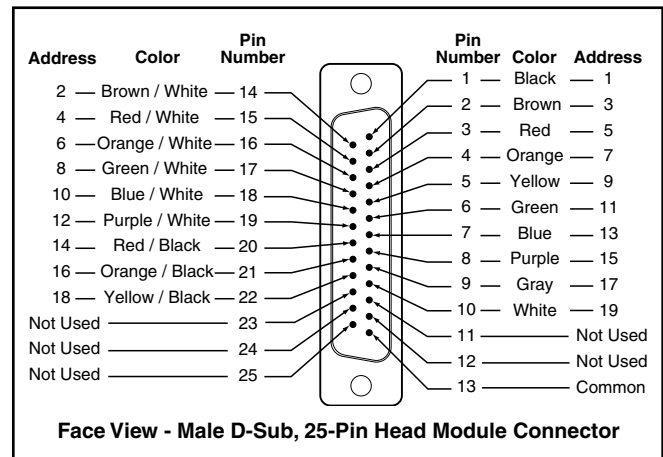

Electrical Specifications

Rated Voltage	24 VDC
Maximum Addresses	19
Maximum Energized Simultaneously	19
Electrical Connection	25-Pin, D-Sub DIN41652, MIL-C-24308, NFC93425 Type HE5
Polarity	Insensitive: PNP and NPN compatible
Dust and Water Protection	IP40



“V” Series 20-Pin, Multi-Connector and Addressing

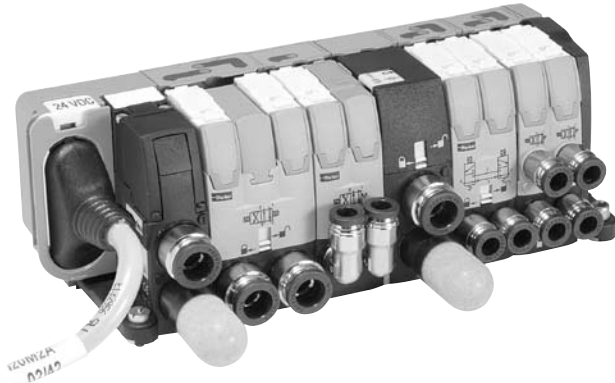

Valve Island Head 20-Pin, Multi-Connector

On the island head module, the multi-connector integrates the HE10 connector standard in its 20-Pin version.

Its plug-in function is secured in position with a guillotine lock with easy access from the front of the island.

Just like the whole island, the multi-connector follows the IP65 protection standard.

Cable Specification:

8.6 mm dia., UL, 20 wires, 0.22mm², AWG 24

Minimum Static Radius: 6.5 mm (.255")

Available with 6.56 ft. (2 m), 16.4 ft. (5 m) and 29.5 ft. (9 m) lengths.

20-Pin, Multi-Connector Addressing

When assembling a **V Series** island, modules are automatically connected to the head module through the modular principle of the integrated electrical connections.

The color code addressing given below conforms to the DIN 47100 standard.

Each wire color corresponds a solenoid pilot position in the island.

Electrical 20-Pin Multi-Connector with Flying Lead Cable (IP65)

Cable Length	Weight (oz)	Order Code
2 m	10.97	P8LMH20M2A
5 m	27.41	P8LMH20M5A
9 m	49.38	P8LMH20M9A

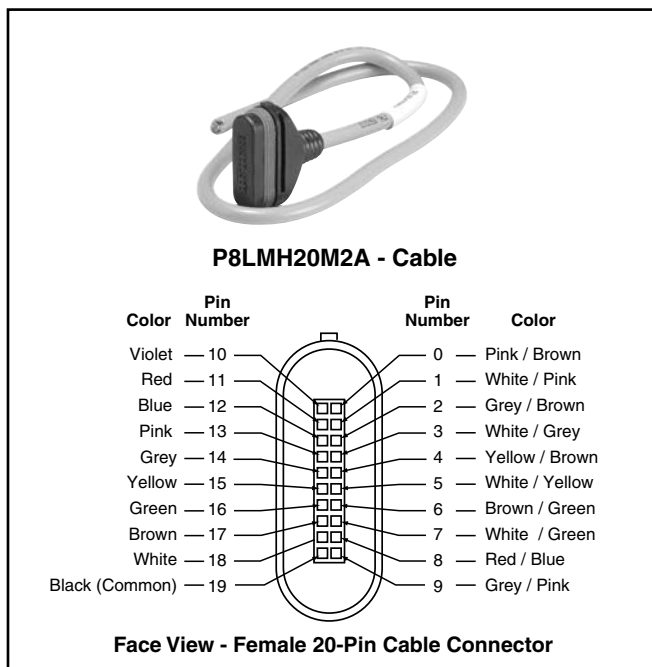
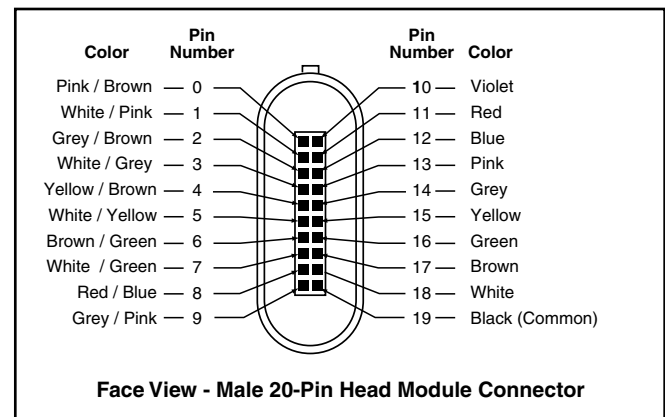

Electrical Specifications

Rated Voltage	24 VDC
Maximum Addresses	19
Maximum Energized Simultaneously	19
Electrical Connection	Type HE10
Polarity	Insensitive: PNP and NPN compatible
Dust and Water Protection	IP65



“V” Series Bus Connections

Valve Island Electrical Head Modules for Bus Connections and Control



P2M2HBVA10808A



P2M2HBVA10808B



P2M2HBVA10800

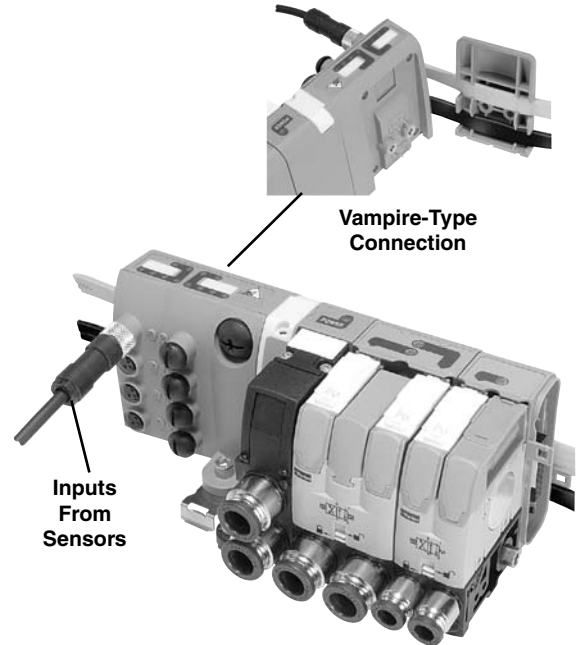

Standard ASi Protocol (up to 31 nodes) Electrical Head Modules

Electrical Module for 8 Solenoids Max.
 (V Series islands may have up to 8 solenoids)
 (2 nodes per module, 4 inputs, 4 solenoids per node)

Input / Output Capability	Weight (oz)	Order Code
0 inputs and 8 solenoid outputs	5.29	P2M2HBVA10800
8 (PNP) inputs on eight (M8) connectors and 8 solenoid outputs	7.05	P2M2HBVA10808A
8 (PNP) inputs on four (M12) connectors and 8 solenoid outputs	7.05	P2M2HBVA10808B

ASi Version 2.1 Protocol (up to 62 nodes) Electrical Head Modules

Electrical Module for 6 Solenoids Max.
 (V Series islands may have up to 6 solenoids)
 (2 nodes per module, 4 inputs, 4 solenoids per node)

Input / Output Capability	Weight (oz)	Order Code
0 inputs and 6 solenoid outputs	5.29	P2M2HBVA20600
8 (PNP) inputs on eight (M8) connectors and 6 solenoid outputs	7.05	P2M2HBVA20608A
8 (PNP) inputs on four (M12) connectors and 6 solenoid outputs	7.05	P2M2HBVA20608B

ASi Bus Accessories

M12 Cable with Jack for Addressing

Length	Weight (oz)	Order Code
1 m	3.53	P8LS12JACK





“V” Series ASi Bus Module: Addressing, Diagnostic, Input Wiring

Bus Addressing, First and Second Node

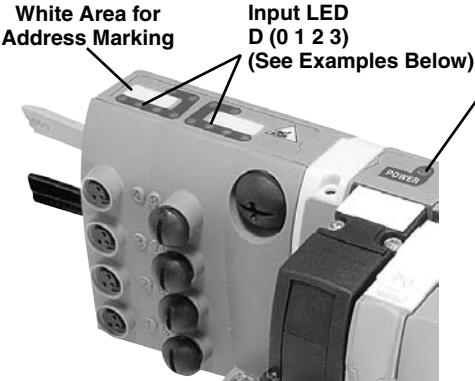
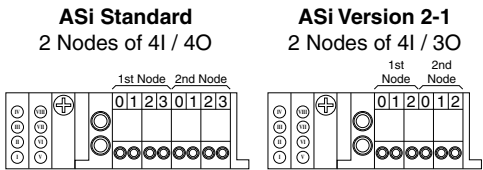
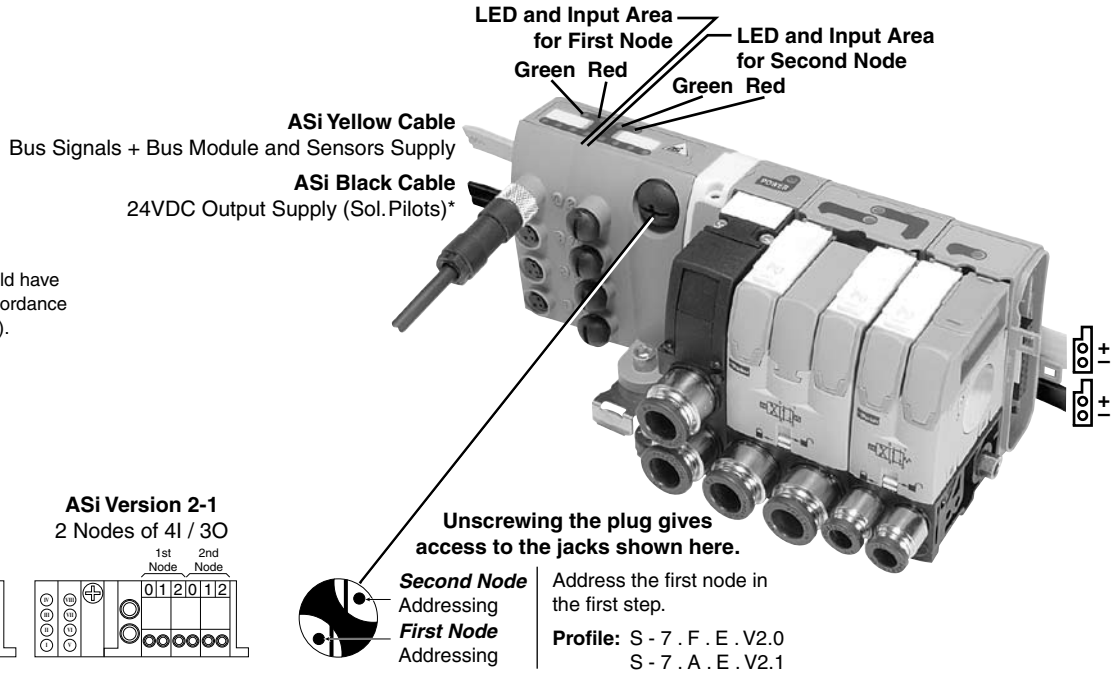

Bus Diagnostic

“Power” LED State	Off	Green	Red
Power Supply	Sol. Pilot Supply	Normal Operation	Solenoid Overload

First Node LEDs State		Second Node LEDs State		System Condition
Green LED	Red LED	Green LED	Red LED	
*	○	*	○	Normal Operation
○	○	○	○	No Module + Sensor Supply
○	*	○	*	Input Overload
○	*	○	*	No ASi Communication
*	*	○	*	Address First Node = 0
*	○	*	*	Address Second Node = 0

* ON ○ OFF * BLINK

Input Wiring

Physical Input (I, II, III, IV) = D (0 1 2 3) First Node,
 Physical Input (V, VI, VII, VIII) = D (0 1 2 3) Second Node.

Examples: Physical Input III = Logical Input 6.2,
 Physical Input V = Logical Input 7.0.

M8 Female Connectors

Pin Out
 1 - 24VDC / ASi
 3 - 0VDC / ASi
 4 - Input

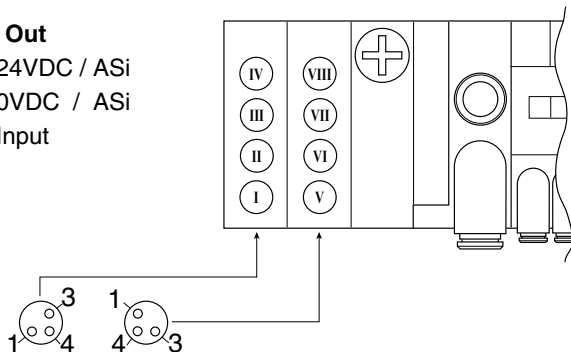

M12 Female Connectors

Pin Out
 1 - 24VDC / ASi
 2 - Second Input
 3 - 0VDC / ASi
 4 - First Input
 5 - Not Connected

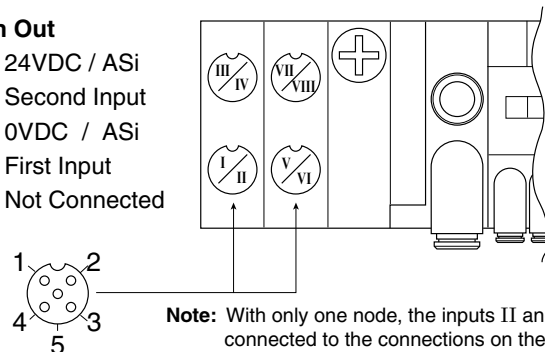



“V” Series Bus Connections Valve Island Electrical Head Modules for Bus Connections and Control



CANopen



INTERBUS-S

Device Bus Electrical Head Modules

Electrical Module for 16 Outputs Max.
(V Series islands may have up to 16 solenoids)



P2M2HBVP11600

Bus Protocol	Weight (oz)	Order Code
Profibus DP	8.82	P2M2HBVP11600
DeviceNet	8.82	P2M2HBVD11600
CANopen	8.82	P2M2HBVC11600
Interbus S	10.58	P2M2HBVS11600

Device Bus Accessories

	Bus Protocol	Connector Type	Weight (oz)	Order Code
Power Supply Female Straight Connector	Profibus DP or Interbus S	M12 type A	0.88	P8CS1205AA
	DeviceNet	M12 type B	0.88	P8CS1205AB
Line Termination Resistor	Profibus DP	M12 type B	0.88	P8BPA00MB
	DeviceNet / CANopen	M12 type A	0.88	P8BPA00MA

Note: Use standard cables and connectors for bus communications from your electrical supplier.

M12 (Male) Power Supply Connector

- 1 - 24VDC Module (Not Connected for DeviceNet)
- 2 - Not Connected
- 3 - 0VDC Module and Solenoid
- 4 - 24VDC Solenoid
- 5 - Protected Earth (PE)

DeviceNet/
CANopen

Bus In
(As Seen
On Module)

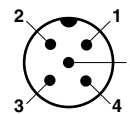

M12 Male
Type A

Profibus DP/
Interbus S

Bus In
(As Seen
On Module)

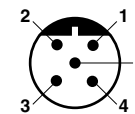

M12 Male
Type B

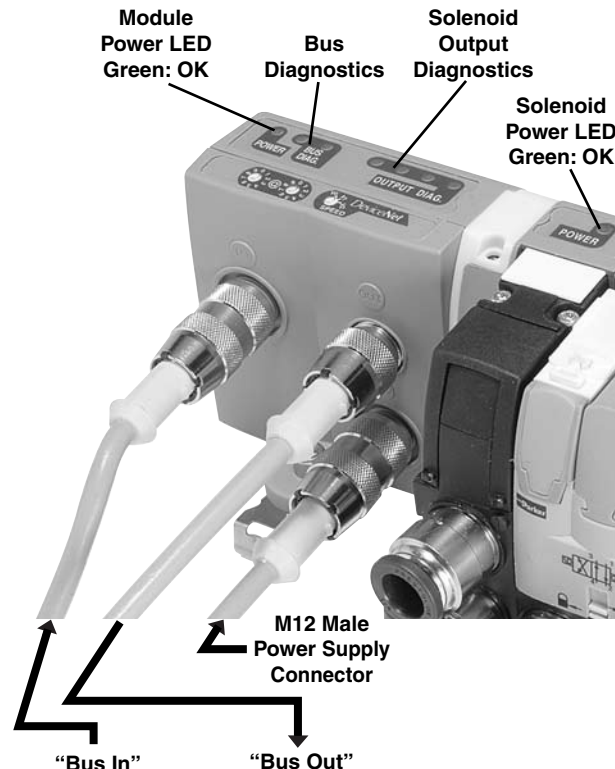

Connection

All bus modules have an M12 male connector for power supply.

Type A or B have been chosen to make them non compatible with M12 bus connectors, thereby avoiding any connection mistake.

Diagnostic

The two “power” indicators shown on the illustrations provide visual indication of the module and solenoid supply status.

Note: Output power to the solenoids can be wired to allow the user to turn the outputs off while allowing communications to remain on. This can be done by placing the user’s Emergency Stop switch or other hard-wired control contact between Pin 1 and Pin 4. If this feature is not required, Pin 1 and Pin 4 should be wired together.



Solenoid Pilot Diagnostic Common to All Device Bus Modules

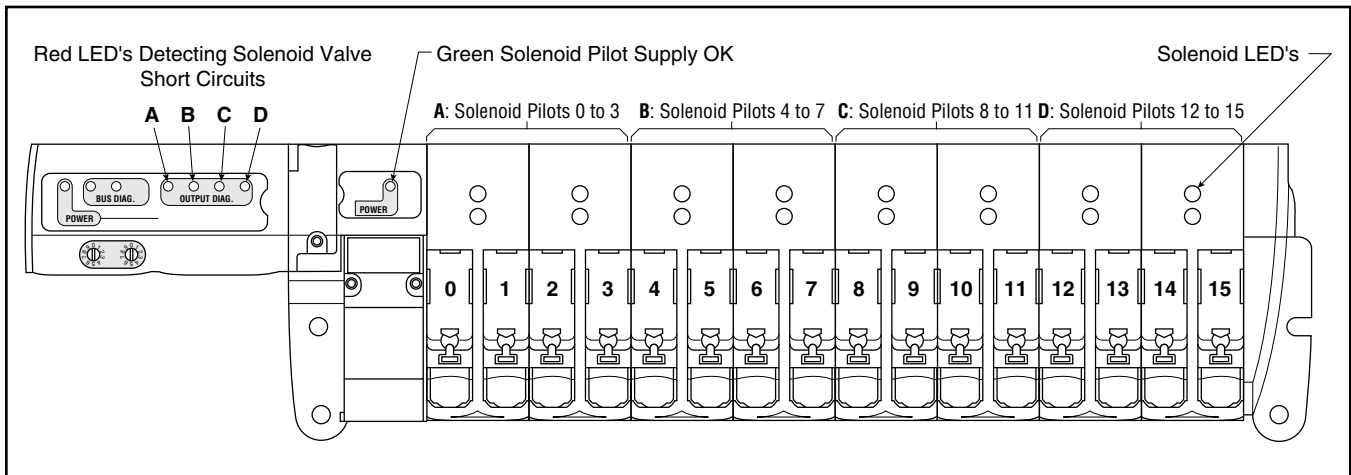

Inside the bus module, solenoid valve control is protected against short-circuits with the following visual indication provided:

- The red LEDs with code, shown above, detect solenoid valve short-circuits.
- Supply is OK when the solenoid pilot power supply indicator is green.

Bus Cable Protection Shield Connections for Profibus DP, DeviceNet and CANopen

To provide protection against electro-magnetic interferences, the bus cables are shielded. The module "bus in" and "bus out" connectors each includes a pin for connecting the cable shield (see next pages). It is safer to connect the shield to the protected earth (PE) at both ends of the bus. Within the bus module, provision is made to enable shield continuity by connection between the two shield pins.

The protected earth have to be connected locally on each module for CE accordance.

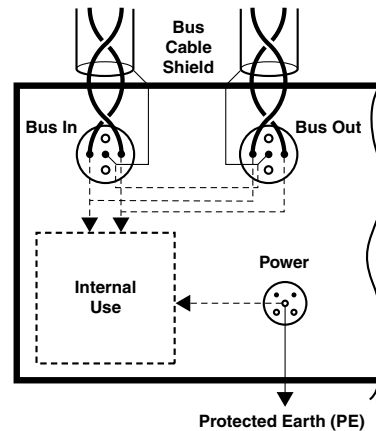



“V” Series Valvetronic™ Device Bus Module: Connections, Addressing, Diagnostic



Bus Cable Connections

Profibus DP standard male and female type B M12 connectors.

Use of prefabricated cables available from your local electrical supplier is recommended.

Line termination P8BPA00MB, is necessary on the “bus out” connector of the last station.

This module incorporates an Autobaud detect feature, eliminating the need to set switches.

Addressing

Use the GSD file on website .

The rotary switches enable configuration of the decimal address.

- www.parker.com/moduflex

Diagnostic

Diagnostic according to the module dialog shown on the illustration.

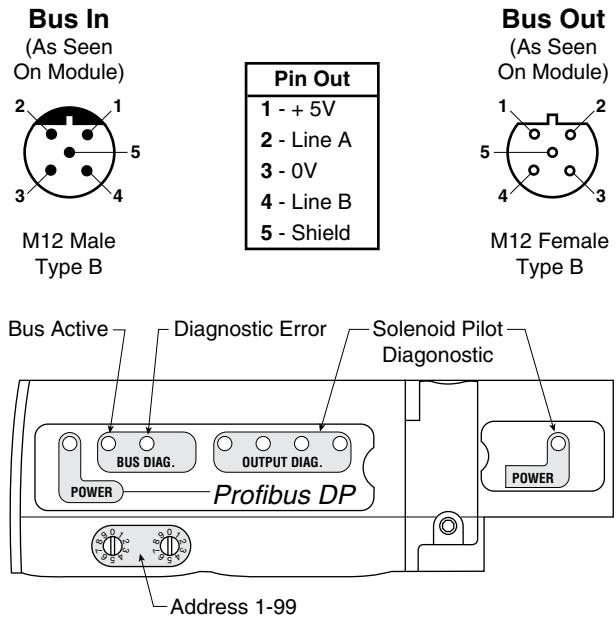

Bus Cable Connections

DeviceNet standard male and female type A M12 connectors.

Use of prefabricated cables available from your local electrical supplier is recommended.

Line termination P8BPA00MA, is necessary on the “bus out” connector of the last station.

Addressing

Use the EDS file on website .

The rotary switches enable configuration of the node address (MAC ID) and the baud rate.

- www.parker.com/moduflex

Diagnostic

Diagnostic according to the module dialog shown on the illustration.

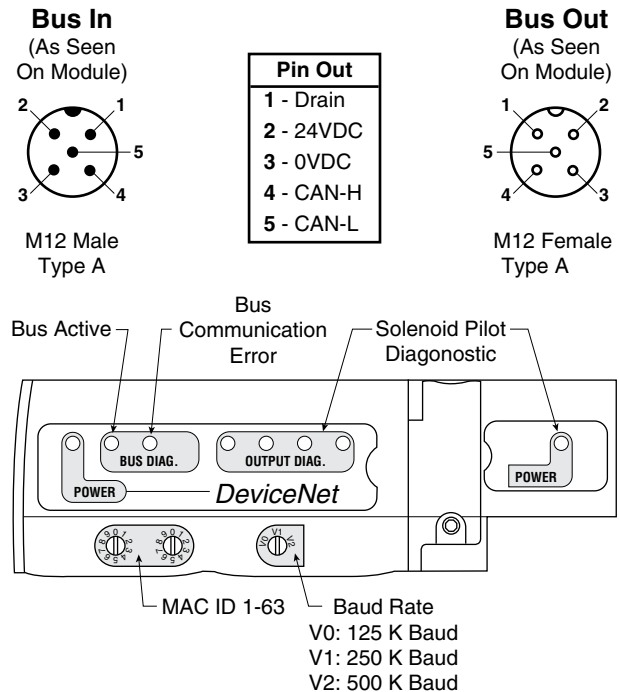

Moduflex

“S” Series Stand-Alone Valve Modules

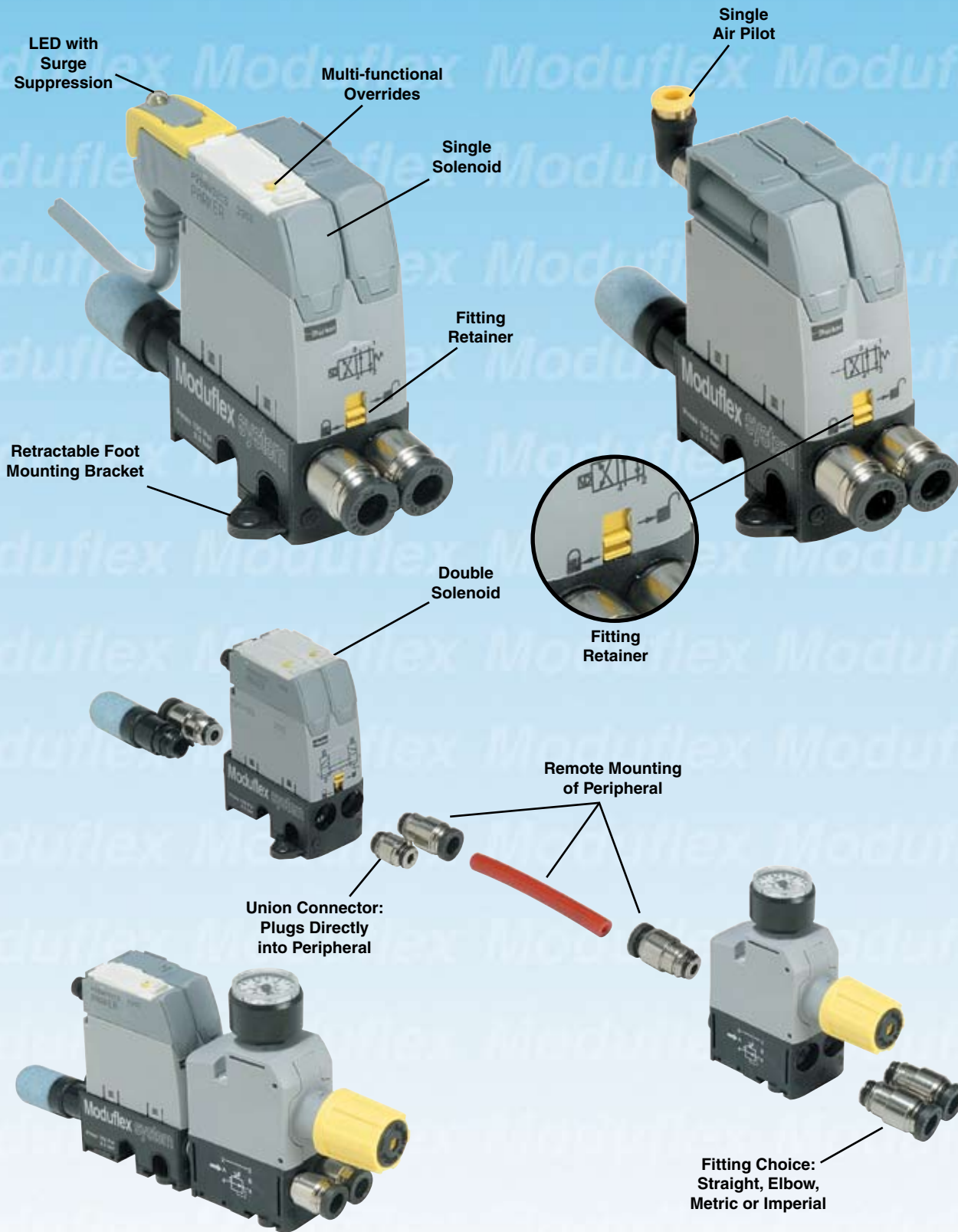

Peripheral modules may either be plugged in the valve output ports or mounted in-line separate from the valve.

Moduflex

“T” Series Island Valve Modules with Peripheral Add-ons

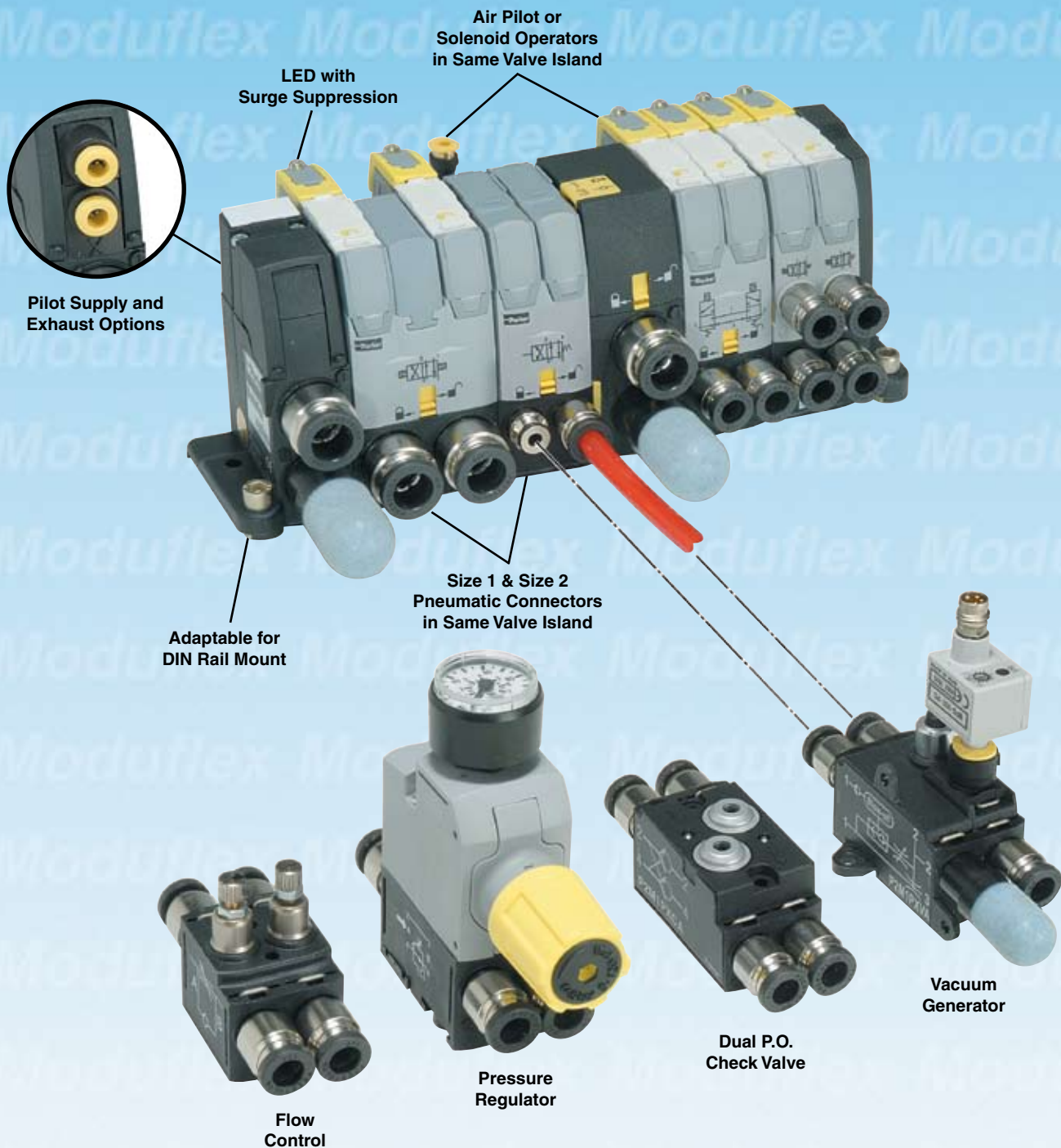

Peripheral modules may either be plugged in the valve output ports or mounted in-line separate from the valve.

Moduflex

“V” Series Island Valve Modules with Integrated Connections

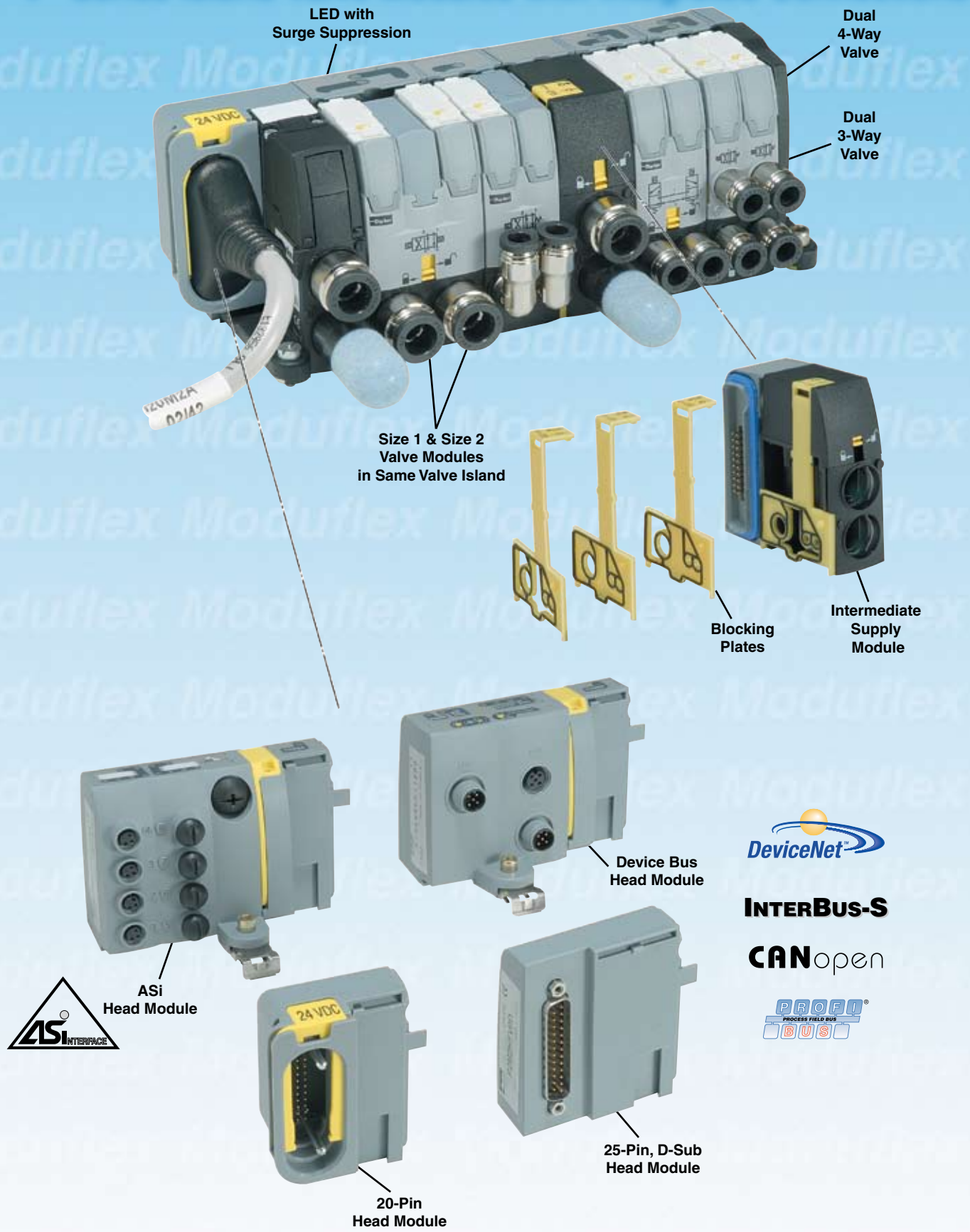

INTERBUS-S

CANopen



Moduflex

“T” Series Valve Island Module Assembly



- For "V" Series Island Modules, install Electrical Head Module to Pneumatic Head End
- For Both "T" and "V" Series Island Modules, install first valve to Pneumatic Head End
- Add additional valve or intermediate air supply modules to the assembly
- Install Pneumatic Tail End.
- Complete Island Installation with appropriate Fittings and Electrical Connectors.
- Individual Valves, Solenoids and Bus Electrical Modules can be removed without disassembling complete Valve Island.
- Assembly and disassembly is accomplished with the use of one TORX wrench.

“V” Series Valve Island Module Assembly





CANopen

Bus Cable Connections

CANopen standard male and female type A M12 connectors.

Use of prefabricated cables available from your local electrical supplier is recommended.

Line termination P8BPA00MA, is necessary on the "bus out" connector of the last station.

Addressing

Use the EDS file on website.

The rotary switches enable configuration of the decimal address.

- www.parker.com/moduflex

Diagnostic

Diagnostic according to the module dialog shown on the illustration.

Bus In
 (As Seen
 On Module)

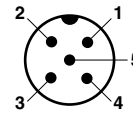

M12 Male
 Type A

Pin Out	
1	- CAN_SHLD
2	- CAN_V+
3	- CAN_GND
4	- CAN_H
5	- CAN_L

CAN_V+ : 24VDC
 module supply

Bus Out
 (As Seen
 On Module)

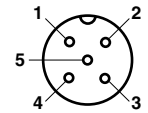

M12 Female
 Type A

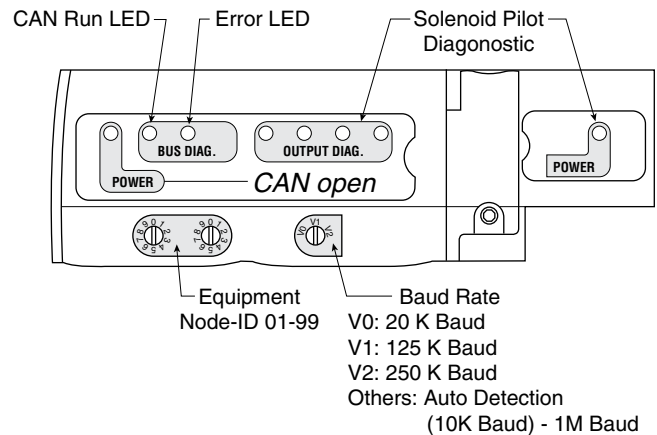

INTERBUS-S

Bus Cable Connections

The M23 connectors conform to "Interbus remote bus".

Use of prefabricated cables available from your usual electrical supplier is recommended.

This module operates at 500 kbps.

Addressing

Interbus S is self addressing; therefore, it does not need any software or hardware configuration.

Diagnostic

Diagnostic according to the module dialog shown on the illustration.

This diagnostic conforms to the Interbus S standard.

Bus In
 (As Seen
 On Module)

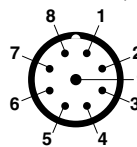

M23 Male

Pin Out	
1	- D0
2	- D0
3	- DI
4	- DI
5	- Ground
6	- PE
7	- +24V
8	- 0V
9	- NC

Pin Out	
1	- D0
2	- D0
3	- DI
4	- DI
5	- Ground
6	- PE
7	- +24V
8	- 0V
9	- RBST

Bus Out
 (As Seen
 On Module)

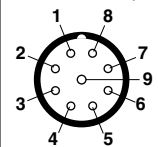

M23 Female

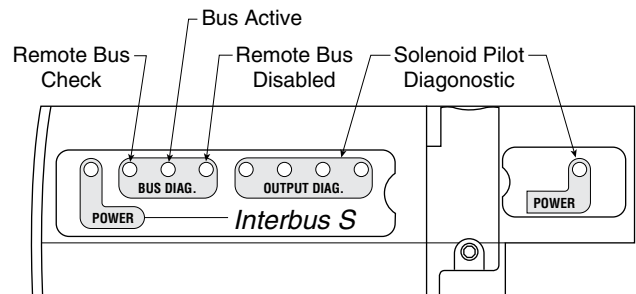

Note: For more details, please consult "Interbus remote bus" documentation.



Serial Bus Specifications

All Buses	EMC / CE Mark	According to EN 61 000-6-2	EN 50081-2
------------------	---------------	----------------------------	------------

ASi Bus	ASi Line	According to EN 50295		
	Solenoid Pilot Voltage	24VDC		
	Module Consumption	max. 70 mA (2 nodes)		
	Max. Supply for All Inputs	240 mA (including internal input consumption)		
	Internal Input Consump.	9 mA for each active input		
	Inputs	According to IEC 1131-2 class 2		
	Certification	These products have been developed according to the association complete specification (v.2.11) and to the slave profiles S-7.F.E or S-B.F.E		

Device Bus	Bus Line	According to each bus specification		
	Module Voltage	20 to 30VDC		
	Solenoid Pilot Voltage	24VDC		
	Module Consumption	Profibus DP max. 1.5W	DeviceNet / CANopen max. 1.5W	Interbus S max. 2W
	Outputs	Overload protection		
	Certification	<u>DeviceNet</u> : Compliant to Composite Test Revision 17, Test Suite: M002		
		<u>Profibus-DP</u> : Compliant to Test Specifications for Profibus DP Slaves, Version 2.0, February 2000, based on EN 50170-2 at Siemens AG in Furth.		
<u>Interbus-S</u> : This product has passed the relevant tests in accordance with the Interbus conformance requirements Certified No. 385.				



I/O Tables Common to All Device Bus Modules

Input Data Table								
Byte	Bit 0	Bit 1	Bit 2	Bit 3	Bit 4	Bit 5	Bit 6	Bit 7
0	Discrete Input 0 (Diagnostic LED 0-3)	Discrete Input 1 (Diagnostic LED 4-7)	Discrete Input 2 (Diagnostic LED 8-11)	Discrete Input 3 (Diagnostic LED 12-15)	—	—	—	—
Output Data Table								
Byte	Bit 0	Bit 1	Bit 2	Bit 3	Bit 4	Bit 5	Bit 6	Bit 7
0	Discrete Output 0	Discrete Output 1	Discrete Output 2	Discrete Output 3	Discrete Output 4	Discrete Output 5	Discrete Output 6	Discrete Output 7
1	Discrete Output 8	Discrete Output 9	Discrete Output 10	Discrete Output 11	Discrete Output 12	Discrete Output 13	Discrete Output 14	Discrete Output 15



Size 1 Pressure Regulation Modules

The thrust developed by a cylinder often requires adjustment by controlling pressure to the front or back of the piston. The pressure regulation module enables manual adjustment of pressure with visual indication provided by the pressure gauge.

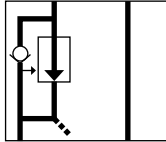

P2M1PXSN

Pressure Regulation Module Without Gauge Size 1

Pressure Range	Size 1
0 to 30 PSI	P2M1PXST Weight 4.06 oz
0 to 60 PSI	P2M1PXSL Weight 4.06 oz
0 to 120 PSI	P2M1PXSN Weight 4.06 oz

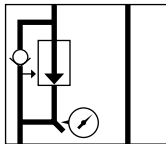

P2M1PXSG



P2M1K0GN

Pressure Regulation Module With Gauge Size 1

Pressure Range	Size 1	Replacement Gauge
0 to 30 PSI	P2M1PXSR Weight 5.12 oz	P2M1K0GT Weight 1.06 oz
0 to 60 PSI	P2M1PXSM Weight 5.12 oz	P2M1K0GL Weight 1.06 oz
0 to 120 PSI	P2M1PXSG Weight 5.12 oz	P2M1K0GN Weight 1.06 oz



Pneumatic Connectors for Size 1 Regulators

		Elbow Version		Straight Version	
		Weight (oz)	Order Code	Weight (oz)	Order Code
Tube Push-in Connector	5/32" = 4mm OD	0.18	CMD04-1	0.07	FMD04-1
	6mm OD	0.18	CMD06-1	0.11	FMD06-1
	1/4" OD	0.18	CMD07-1B	0.11	FMD07-1B
Plug	—	—	—	0.18	PMDYY1
Double Male Union (For Peripheral Valve Modules)	—	—	—	0.21	HMDXX1

Note: 85 Durometer minimum for pneumatic connectors.



Size 2 Regulation Modules

The thrust developed by a cylinder often requires adjustment by controlling pressure to the front or back of the piston. The pressure regulation module enables manual adjustment of pressure with visual indication provided by the pressure gauge.

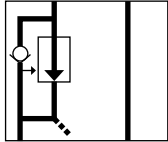

P2M2PXSN

Pressure Regulation Module Without Gauge Size 2

Pressure Range	Size 2
0 to 30 PSI	P2M2PXST Weight 6.00 oz
0 to 60 PSI	P2M2PXSL Weight 6.00 oz
0 to 120 PSI	P2M2PXSN Weight 6.00 oz

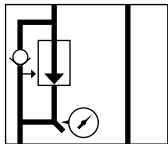

P2M2PXSR



P2M1K0GN

Pressure Regulation Module With Gauge Size 2

Pressure Range	Size 2	Replacement Gauge
0 to 30 PSI	P2M2PXSR Weight 4.94 oz	P2M1K0GT Weight 1.06 oz
0 to 60 PSI	P2M2PXSM Weight 4.94 oz	P2M1K0GL Weight 1.06 oz
0 to 120 PSI	P2M2PXSG Weight 4.94 oz	P2M1K0GN Weight 1.06 oz



PMDYY2



HMDXX2



FMD09-2



CMD13-2

Pneumatic Connectors for Size 2 Regulators

		Elbow Version		Straight Version	
		Weight (oz)	Order Code	Weight (oz)	Order Code
Tube Push-in Connector	6mm OD	0.18	CMD06-2	0.11	FMD06-2
	1/4" OD	0.18	CMD07-2B	0.11	FMD07-2B
	8mm OD	0.21	CMD08-2	0.14	FMD08-2
	3/8" OD	0.21	CMD09-2B	0.14	FMD09-2B
	10mm OD	0.25	CMD10-2	0.18	FMD10-2
	12mm OD	0.28	CMD12-2	0.21	FMD12-2
1/2" OD	—	—	0.21	FMD13-2B	
Plug	—	—	—	0.18	PMDYY2
Double Male Union (For Peripheral Valve Modules)	—	—	—	0.28	HMDXX2

Note: 85 Durometer minimum for pneumatic connectors.



Dual P.O. Check Valve

Combined with a double 3/2 NC + NC valve, this module will block both flows and stop cylinder movement as soon as the valve's outputs are both exhausted. Better than a 3-Position valve, it provides more precise positioning when fitted close to the cylinder. Standard with manual release buttons.

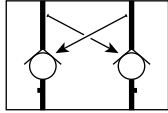

P2M1PXCA

Application

At the outputs of a double 3/2 NC + NC valve, the dual P.O. check valve module achieves efficient and stable cylinder positioning. As soon as both lines are exhausted by the main control valve, the two internally piloted check valves close tight. The cylinder is then stabilized.

The manual pressure releases may then eventually be used for an adequate machine positioning.

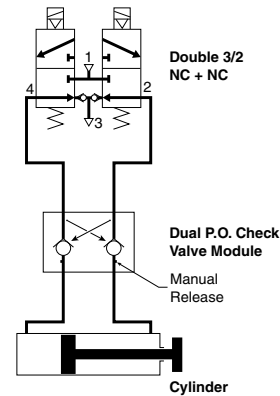

Dual P.O. Check Valve Size 1

Description	Size 1
Dual Pilot Operated	P2M1PXCA Weight .88 oz

Dual P.O. Check Valve Size 2

Description	Size 2
Dual Pilot Operated	P2M2PXCA Weight .88 oz



Pneumatic Connectors for Size 1 Dual P.O. Check Valves

		Elbow Version		Straight Version	
		Weight (oz)	Order Code	Weight (oz)	Order Code
Tube Push-in Connector	5/32" = 4mm OD	0.18	CMD04-1	0.07	FMD04-1
	6mm OD	0.18	CMD06-1	0.11	FMD06-1
	1/4" OD	0.18	CMD07-1B	0.11	FMD07-1B
Double Male Union (For Peripheral Valve Modules)	—	—	—	0.21	HMDXX1

Pneumatic Connectors for Size 2 Dual P.O. Check Valves

		Elbow Version		Straight Version	
		Weight (oz)	Order Code	Weight (oz)	Order Code
Tube Push-in Connector	6mm OD	0.18	CMD06-2	0.11	FMD06-2
	1/4" OD	0.18	CMD07-2B	0.11	FMD07-2B
	8mm OD	0.21	CMD08-2	0.14	FMD08-2
	3/8" OD	0.21	CMD09-2B	0.14	FMD09-2B
	10mm OD	0.25	CMD10-2	0.18	FMD10-2
	12mm OD	0.28	CMD12-2	0.21	FMD12-2
Double Male Union (For Peripheral Valve Modules)	—	—	—	0.28	HMDXX2

Note: 85 Durometer minimum for pneumatic connectors.

Note: 85 Durometer minimum for pneumatic connectors.



Dual Flow Control

By controlling the exhaust flows of a double-acting cylinder, this module can adjust both speeds — extend and retract. It may be plugged into the valve module output ports or mounted close to the cylinder in its in-line version.

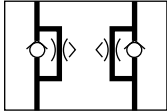

P2M1PXFA

Application

On a double-acting cylinder, extend and retract speeds are adjusted separately by control of air flow exhaust. The control becomes more precise when the flow adjustment is close to the cylinder. The examples show different solutions which are dependent upon the valve-to-cylinder distance and accessibility to the cylinder

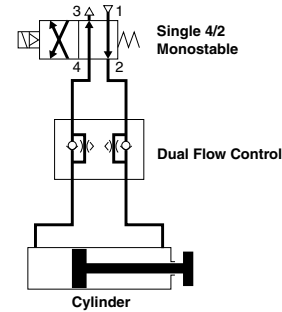

Dual Flow Control Size 1

Description	Size 1
Dual Flow Control Module	P2M1PXFA Weight 1.06 oz

Dual Flow Control Size 2

Description	Size 2
Dual Flow Control Module	P2M2PXFA Weight 1.59 oz



HMDXX1

FMD04-1

CMD04-1

FMD07-1B

CMD07-1B

Pneumatic Connectors for Size 1 Dual P.O. Check Valves

		Elbow Version		Straight Version	
		Weight (oz)	Order Code	Weight (oz)	Order Code
Tube Push-in Connector	5/32" = 4mm OD	0.18	CMD04-1	0.07	FMD04-1
	6mm OD	0.18	CMD06-1	0.11	FMD06-1
	1/4" OD	0.18	CMD07-1B	0.11	FMD07-1B
Double Male Union (For Peripheral Valve Modules)	—	—	—	0.21	HMDXX1

Note: 85 Durometer minimum for pneumatic connectors.



HMDXX2

FMD09-2

CMD13-2

Pneumatic Connectors for Size 2 Dual P.O. Check Valves

		Elbow Version		Straight Version	
		Weight (oz)	Order Code	Weight (oz)	Order Code
Tube Push-in Connector	6mm OD	0.18	CMD06-2	0.11	FMD06-2
	1/4" OD	0.18	CMD07-2B	0.11	FMD07-2B
	8mm OD	0.21	CMD08-2	0.14	FMD08-2
	3/8" OD	0.21	CMD09-2B	0.14	FMD09-2B
	10mm OD	0.25	CMD10-2	0.18	FMD10-2
	12mm OD	0.28	CMD12-2	0.21	FMD12-2
Double Male Union (For Peripheral Valve Modules)	1/2" OD	—	—	0.21	FMD13-2B
Double Male Union (For Peripheral Valve Modules)	—	—	—	0.28	HMDXX2

Note: 85 Durometer minimum for pneumatic connectors.



“P” Series Peripheral Modules Model Number Index
 Complete Modules *(Complete with Pneumatic Connectors)*

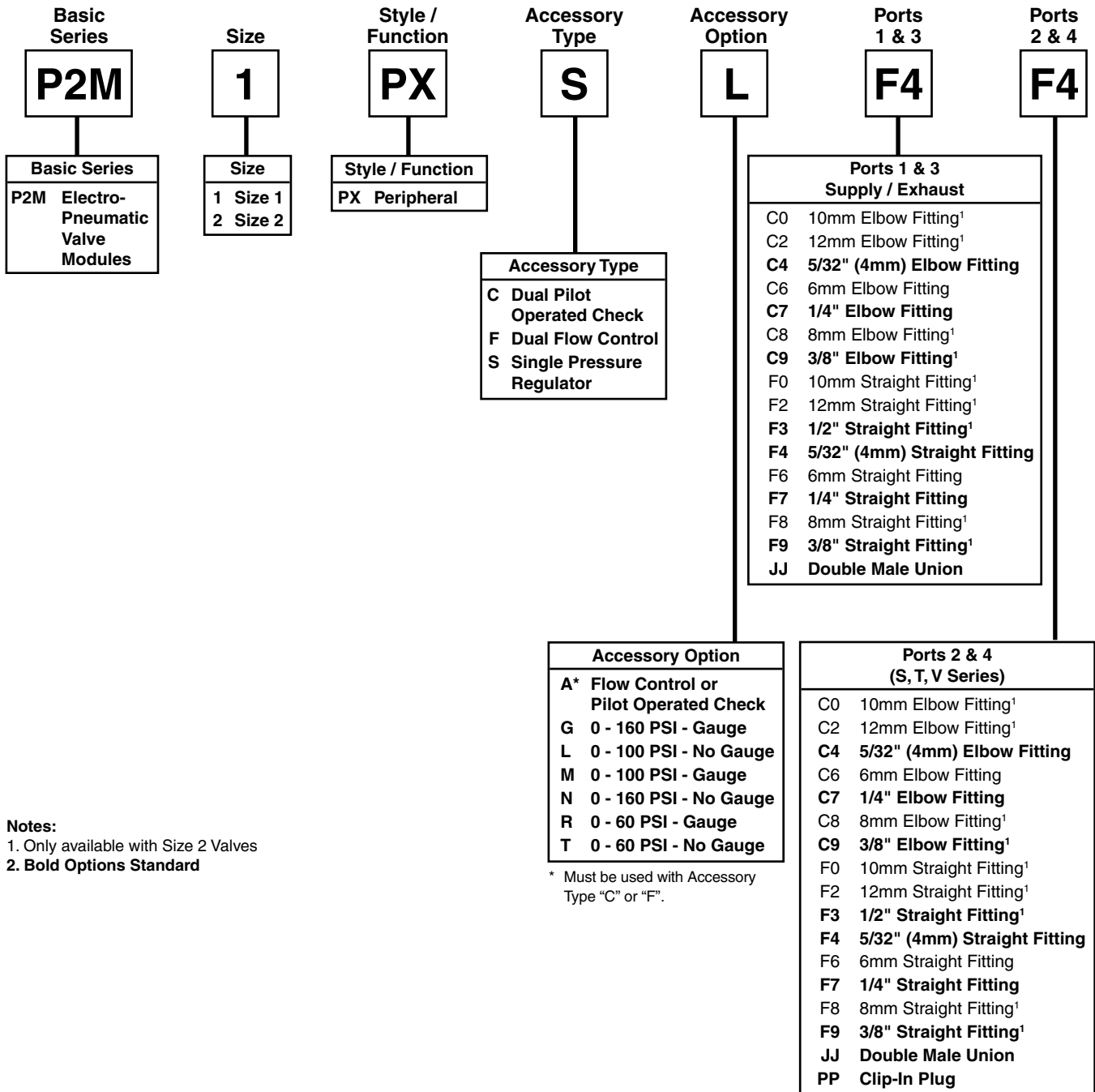

Notes:
 1. Only available with Size 2 Valves
 2. **Bold Options Standard**

* Must be used with Accessory Type "C" or "F".



Regulator with Gauge

Example:

Size 1, Regulator with gauge, 1/4” OD straight fittings.

How to Order Complete Peripheral Module

Line Item	Quantity	Part Number	Description
1	1	P2M1PXSGF7F7	Size 1, Regulator with 0-160 PSI Gauge, 1/4" OD Straight Port Fittings in port 1, 2, 3, 4

How to Order Components

Line Item	Quantity	Part Number	Description
1	1	P2M1PXSG	Size 1, Regulator with 0-160 PSI Gauge
2	4	FMD07-1B	Size 1-1/4" OD Tube Push-In Connector



Flow Control with Fittings

Example:

Size 1, Dual Flow Control, 1/4” OD Straight Fittings.

How to Order Complete Peripheral Module

Line Item	Quantity	Part Number	Description
1	1	P2M1PXFAF7F7	Size 1, Dual Flow Control, 1/4" OD Straight Port Fittings in Port 1, 2, 3, 4

How to Order Components

Line Item	Quantity	Part Number	Description
1	1	P2M1PXFA	Size 1, Dual Flow Control
2	4	FMD07-1B	Size 1-1/4" OD Tube Push-In Connector



Vacuum Generator Module



Depending on the application requirements, this vacuum generator module may be controlled by single or by a dual 3/2 Moduflex valve module. The Vacuum Module has an integrated blow-off chamber that helps destroy the degree of vacuum. Blow-off can be increased with the addition of a control air input to the blow-off port on the vacuum module. A Ø6 mm port is available for an optional plug-in vacuum sensor for delivering a vacuum feedback signal.

Vacuum Generator Module Size 1

Description	Size 1
Vacuum Generator	P2M1PXVA Weight .88 oz

Pneumatic Connectors for Size 1 Vacuum Generator Modules

		Elbow Version		Straight Version	
		Weight (oz)	Order Code	Weight (oz)	Order Code
Tube Push-in Connector	5/32" = 4mm OD	0.18	CMD04-1	0.07	FMD04-1
	6mm OD	0.18	CMD06-1	0.11	FMD06-1
	1/4" OD	0.18	CMD07-1B	0.11	FMD07-1B
Muffler for Exhaust Port	—	—	—	0.11	MMDVA-1
Double Male Union (For Peripheral Valve Modules)	—	—	—	0.21	HMDXX1

Note: 85 Durometer minimum for pneumatic connectors.

Vacuum Generator Module Model Number Index

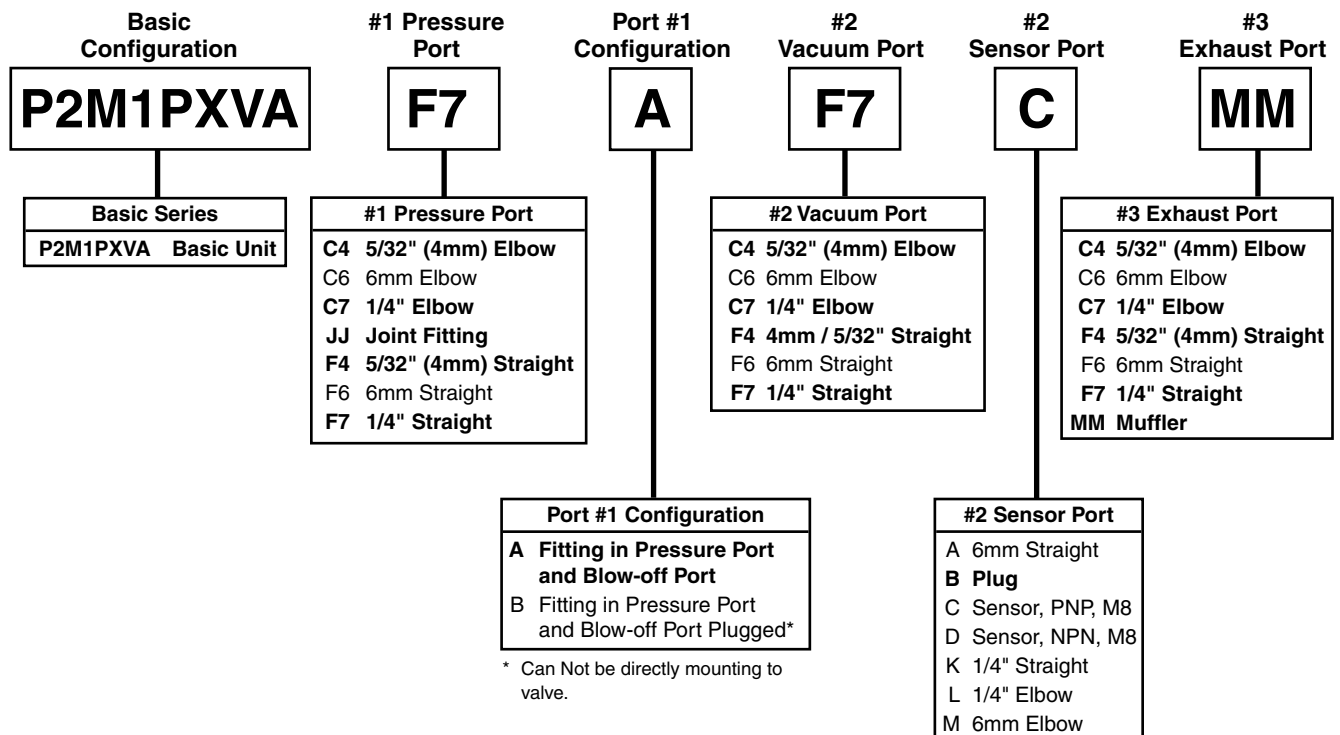



Vacuum Generator Applications



Single 3/2 NC Air Control Valve

The 3/2 valve delivers the air supply to generate vacuum through the venturi. It also pressurizes the integrated blow-off chamber. When the 3/2 valve cuts-off the air supply, this chamber is automatically exhausted into the vacuum channel in order to speed-up the part release. In this type of application, it is preferred to have the vacuum generator mounted away from the control valve.

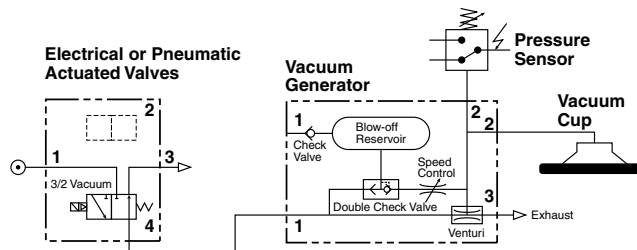

Dual 3/2 3/2 Valve Control

One 3/2 valve controls air supply for vacuum. The other 3/2 valve will generate an additional blow-off that may prove necessary to obtain quick part release from large vacuum pads. The effect of the blow-off can be controlled with an adjustable screw. In this type of circuit, the Vacuum Generator can be mounted directly to the valve by using Double Male Unions or as a stand alone item away from the control valve.

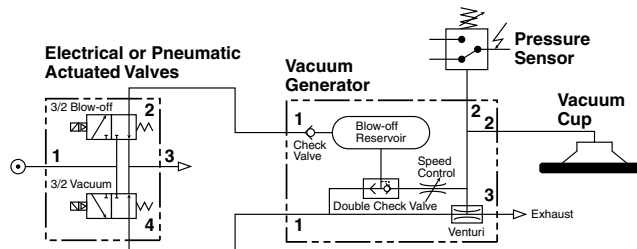

MPS-6 Sensor Ordering Numbers

Pressure Range	Port Size	Output Circuit	Electrical Connector	Part Number
0 to -30 inHg	6mm Tube Stud	PNP Sourcing	4 Pin, M8	MPS-V6T-PC*
		NPN Sinking		MPS-V6T-NC*

* If ordering the sensor separate from the vacuum module, install a 6mm straight fitting in #2 sensor port for direct mounting.

Sensor Cable Part Numbers

Item	Connector	Contacts	Length	Cover
CB-M8-4P-2M	M8 Female	4	2m	PVC
CB-M8-4P-5M	M8 Female	4	5m	PUR

Vacuum Flow (SCFM)

Nozzle Diameter	inHg										
	0	3	6	9	12	15	18	21	24	27	30
P2M1PXVA	0.84	0.76	0.67	0.55	0.42	0.30	0.18	0.06	—	—	—

Evacuation Time

Series / Nozzle Diameter	Air Supply Pressure	Air Consumption	Evacuation Time in sec / ft ³ * to reach different Vacuum Levels (inHg)								
	PSI	SCFM	3	6	9	12	15	18	21	24	27
P2M1PXVA	70	1.60	5.6	14.2	22.0	42.4	62.3	85.0	116	198	—

* 1 ft³ = 28.31 liters





Intermediate Supply Module Model Number Index

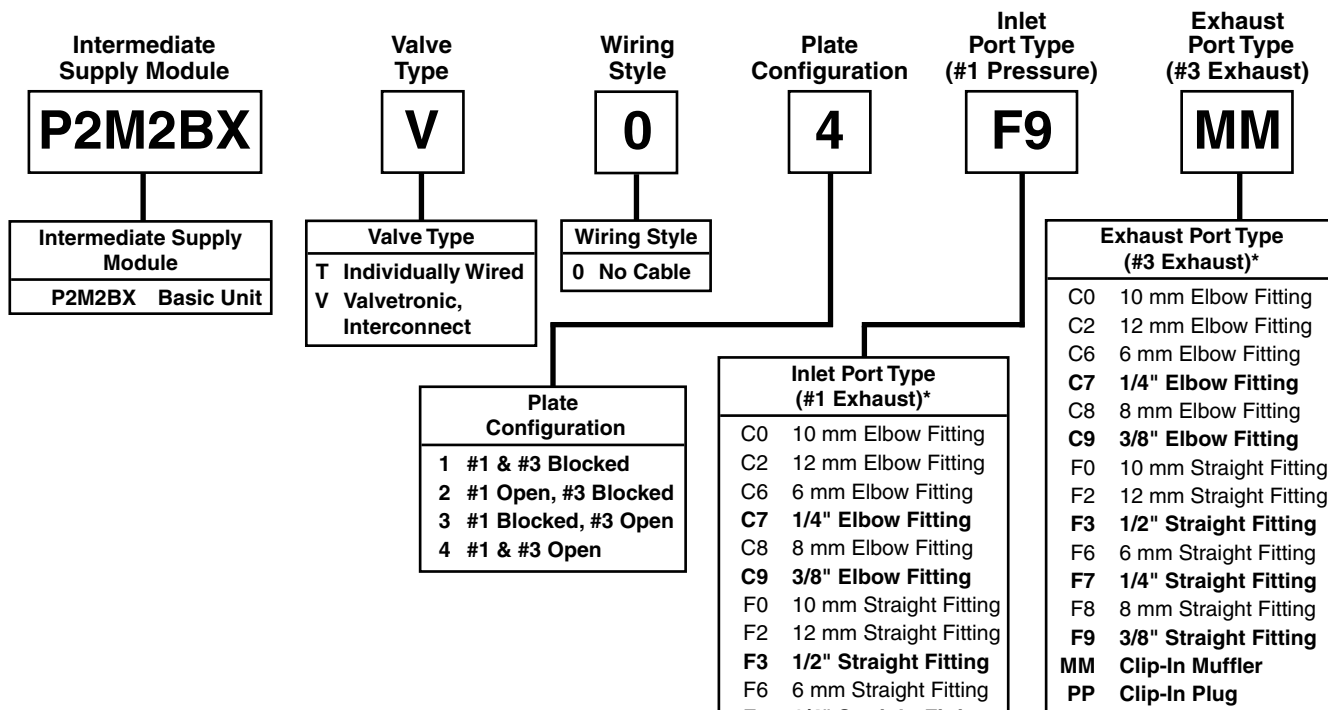

* Elbow fittings face up.

Plate Configuration



* Elbow fittings face up.

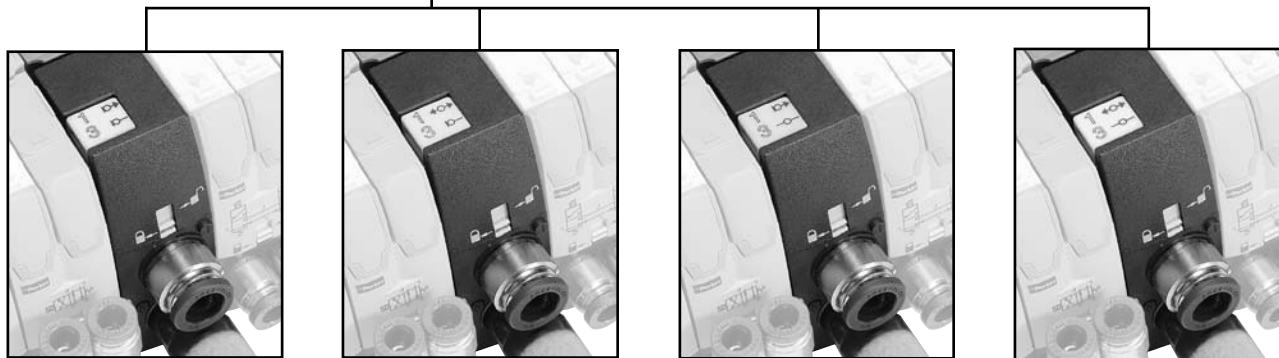

#1 & #3 Blocked

#1 Port connected to valves on the right only. Left is blocked.
 #3 Port connected to valves on the right only. Left is blocked.

#1 Open, #3 Blocked

#1 Port connected to valves on the right and the left.
 #3 Port connected to valves on the right only. Left is blocked.

#1 Blocked, #3 Open

#1 Port connected to valves on the right only. Left is blocked.
 #3 Port connected to valves on the right and the left.

#1 & #3 Open

#1 Port connected to valves on the right and the left.
 #3 Port connected to valves on the right and the left.



Internal and External Pilot Supply Options

All T and V Series Valves subbases incorporate an auxiliary channel “X” to supply pressure to the solenoid pilots. The “X” galley is pressurized from the head module. Depending on the configuration of the head module, this pressure is either supplied from the #1 port in the head module or supplied externally through a 4mm OD tube fitting in the head module. This fitting is supplied in all head modules and can be converted in the field.

Internal and External Solenoid Pilot Exhaust Options

All T and V Series Valves subbases incorporate an auxiliary channel “E” which is used to exhaust the solenoid pilot pressure from each solenoid valve. The “E” galley is connected to the head module. Depending on the configuration of the head module, this exhaust is either connected to the #3 exhaust port or is connected to a 4mm OD Tube fitting in the head module. This fitting is supplied in all head modules and can be converted in the field.

To configure the head module, with pressure off, remove head cover to expose the selector section. Loosen selector section and rotate “X” or “E” channel selector to desired position. Tighten selector section and assemble head cover.

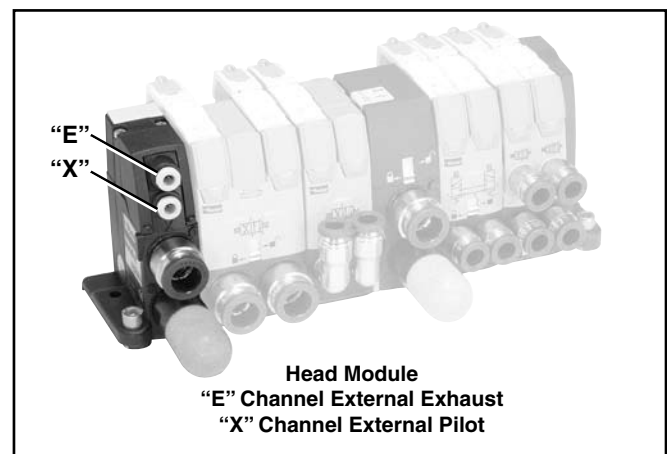
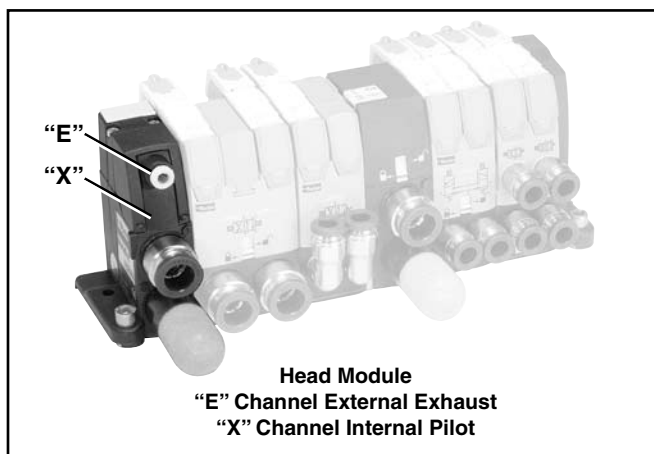
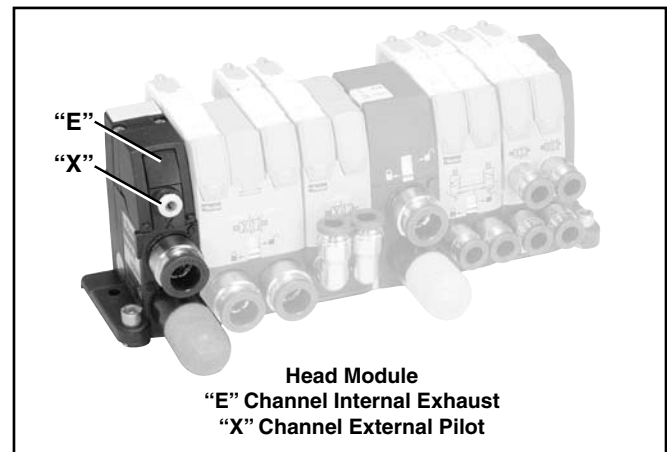
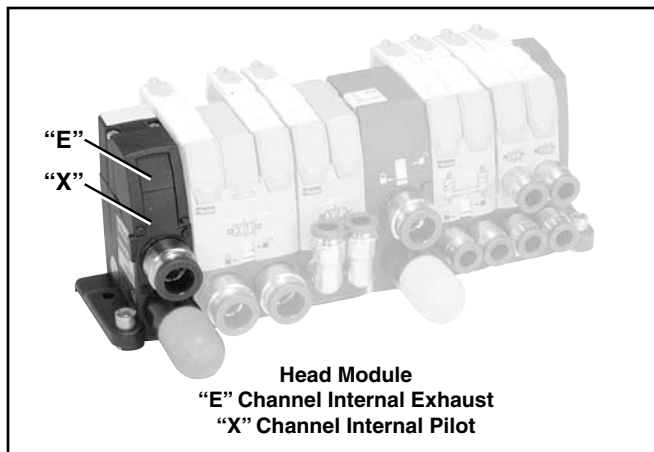
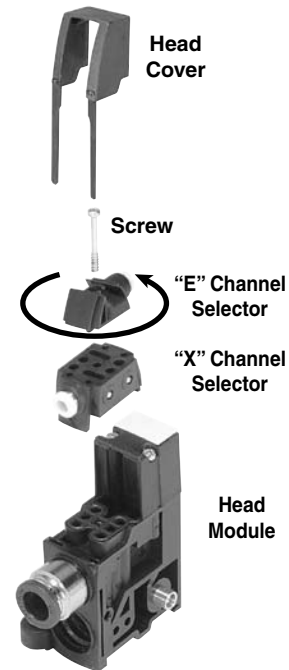



Moduflex Island Assembly Model Number Index

Complete Modules *(Complete with Pneumatic and Electrical Connectors)*

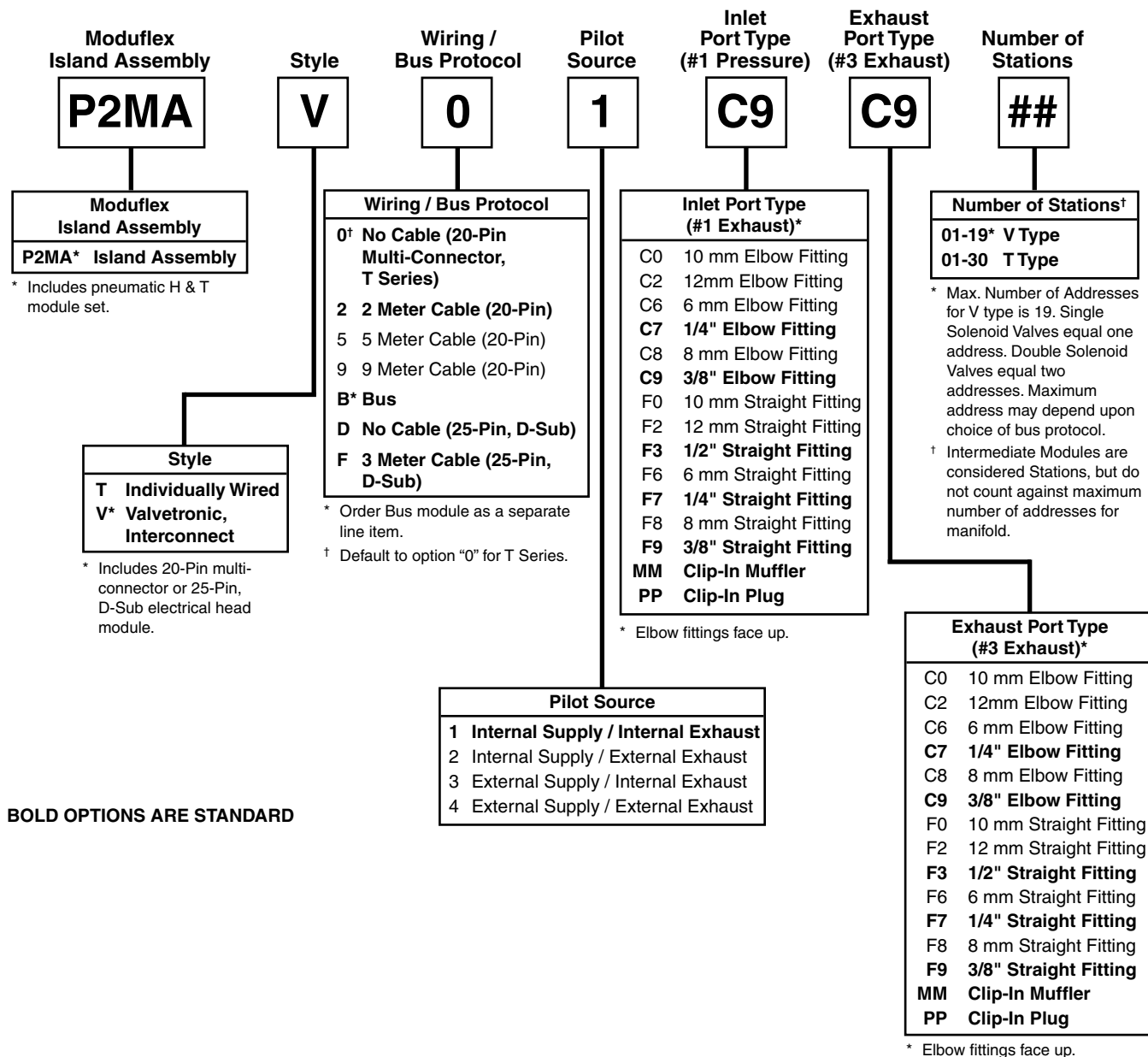

BOLD OPTIONS ARE STANDARD



"V" Series with 20-Pin Connector



"V" Series with Field Bus Connection



Example:

Application requires V Series valves with 20-Pin, D-Sub and 2 Meter cable. Manifold to include (1) Size 2, 4/2 Double Solenoid Valve - 3/8" OD fitting, (1) Size 1, 4/2 Single Solenoid Valve - 1/4" OD Elbow Fitting, Intermediate Module - 3/8" OD Fitting with Exhaust Muffler, Port 1 and 3 Blocked, (1) Size 1, Dual 3/2 NC Valve and (1) Size 1, 4-Way Double Solenoid Valve both with 1/4" OD Straight Fittings. Includes 3/8 OD Inlet Fitting and Exhaust Muffler.

How to Order Complete Manifold Assembly

Line Item	Quantity	Part Number	Description
1	1	P2MAV21F9MM05	Moduflex Island Assembly, Pneumatic Head and Tail Module Set, Internal Pilot Supply, Internal Pilot Exhaust, 3/8" Straight Fitting Port 1, Port 3 Muffler.
2	1	P2M2V4EE2CV00F9	Size 2, Double Solenoid, 4/2, 3/8" Straight Pneumatic Connectors.
3	1	P2M1V4ES2CV00C7	Size 1, Single Solenoid, 1/4" Elbow Pneumatic Connectors.
4	1	P2MBXV0A1F9MM	Intermediate Module 3/8" Straight Fitting with Exhaust Muffler
5	1	P2M1V4ES2CV00C7	Size 1, Dual 3/2 NC + NC, 1/4" Elbow Pneumatic Connectors.
6	2	P2M1VJEE2CV00F7	Size 1, Dual 4/2, 1/4" Straight Pneumatic Connectors.

How to Order Components

Line Item	Quantity	Part Number	Description
1	1	P2M2HXT01	Pneumatic Head and Tail Module Set
2	1	P2M2HEV0A	20-Pin, Multi-Connector Electrical Head Module
3	1	P8LMH20M2A	2 Meter, 20-Pin, D-Sub Cable
4	1	P2M2V4EE2CV	Size 2, V Series Island Valve Module, Double Solenoid, 4-Way
5	1	P2M1V4ES2CV	Size 1, V Series Island Valve Module, Single Solenoid, 4-Way
6	1	P2M2BXV0A	Intermediate Module
7	1	P2M1V4ES2CV	Size 1, V Series Island Valve Module, Dual 3/2 NC + NC
8	2	P2M1V4EE2CV	Size 1, V Series Island Valve Module, Dual 4/2
9	2	CMD07-1B	Size 1, 1/4" OD Tube Elbow Push-in Connector
10	6	FMD07-1B	Size 1, 1/4" OD Tube Straight Push-in Connector
11	4	FMD09-2B	Size 2, 3/8" OD Tube Straight Push-in Connector
12	2	MMDVA2	Clip-on Muffler

Example:

Application requires V Series valves with DeviceNet Communications Module. Manifold to include (1) Size 2, 4/2 Double Solenoid Valve - 3/8" OD fitting, (1) Size 1, 4/2 Single Solenoid Valve - 1/4" OD Elbow Fitting, Intermediate Module - 3/8" OD fitting with Exhaust Muffler, Port 1 and 3 Blocked, (1) Size 1, Dual 3/2 NC Valve and (1) Size 1, 4-Way Double Solenoid Valve both with 1/4" OD Straight Fittings. Include 3/8 OD Inlet Fitting and Exhaust Muffler.

How to Order Complete Manifold Assembly

Line Item	Quantity	Part Number	Description
1	1	P2MAVB1F9MM05	Moduflex Island Assembly, Pneumatic Head and Tail Module Set, Internal Pilot Supply, Internal Pilot Exhaust, 3/8" Straight Fitting Port 1, Port 3 Muffler.
2	1	P2M2HBVD11600	DeviceNet Module
2	1	P2M2V4EE2CV00F9	Size 2, Double Solenoid, 4/2, 3/8" Straight Pneumatic Connectors.
3	1	P2M1V4ES2CV00C7	Size 1, Single Solenoid, 1/4" Elbow Pneumatic Connectors.
4	1	P2MBXV0A1F9MM	Intermediate Module 3/8" Straight Fitting with Exhaust Muffler
5	1	P2M1V4ES2CV00C7	Size 1, Dual 3/2 NC + NC, 1/4" Elbow Pneumatic Connectors.
6	2	P2M1VJEE2CV00F7	Size 1, Dual 4/2, 1/4" Straight Pneumatic Connectors.

How to Order Components

Line Item	Quantity	Part Number	Description
1	1	P2M2HXT01	Pneumatic Head and Tail Module Set
2	1	P2M2HBVD11600	DeviceNet Module
3	1	P2M2V4EE2CV	Size 2, V Series Island Valve Module, Double Solenoid, 4-Way
4	1	P2M1V4ES2CV	Size 1, V Series Island Valve Module, Single Solenoid, 4-Way
5	1	P2M2BXV0A	Intermediate Module
6	1	P2M1V4ES2CV	Size 1, V Series Island Valve Module, Dual 3/2 NC + NC
7	2	P2M1V4EE2CV	Size 1, V Series Island Valve Module, Dual 4/2
8	2	CMD07-1B	Size 1, 1/4" OD Tube Elbow Push-in Connector
9	6	FMD07-1B	Size 1, 1/4" OD Tube Straight Push-in Connector
10	4	FMD09-2B	Size 2, 3/8" OD Tube Straight Push-in Connector
11	2	MMDVA2	Clip-on Muffler





“V”, “T” and “S” Series Maintenance

The latest generations of compact pneumatic valves have a life expectancy which generally exceeds the equipment they control. Therefore, maintenance is seldom required. When it

is necessary to change the solenoid pilot, valve or connector, they can be easily replaced without removing the island base, as shown below.

“S” Series

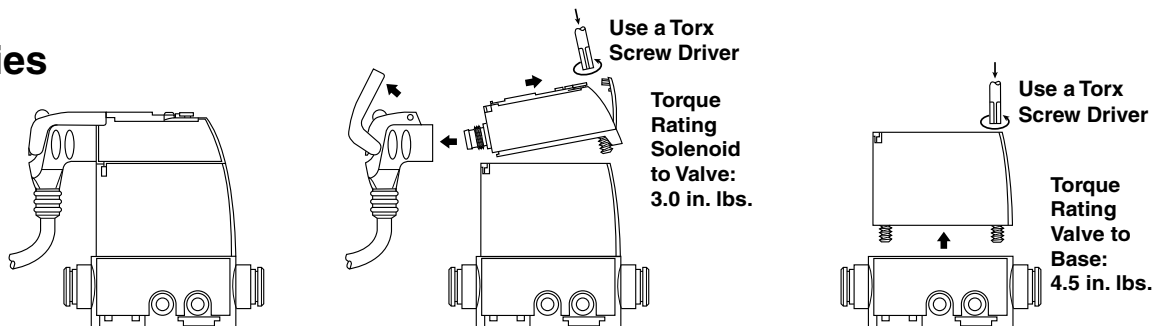

“T” Series

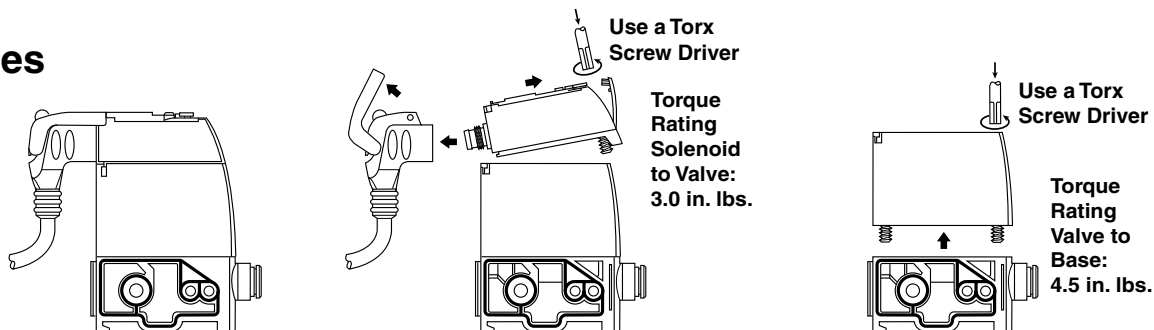

“V” Series

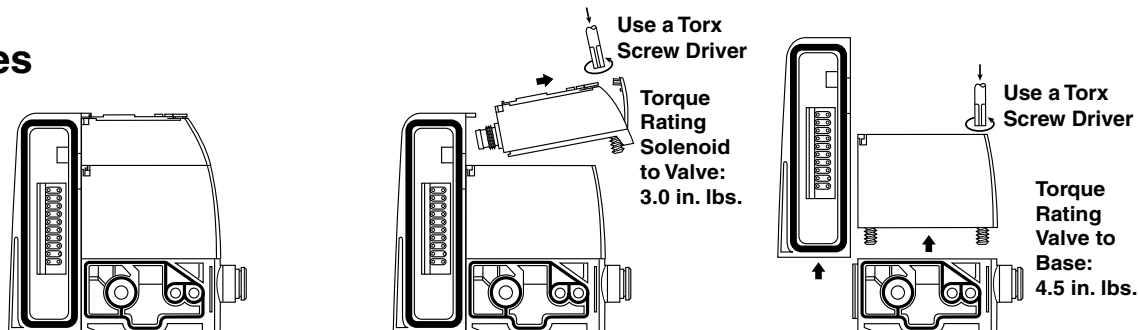

Fitting and Tubing Installation

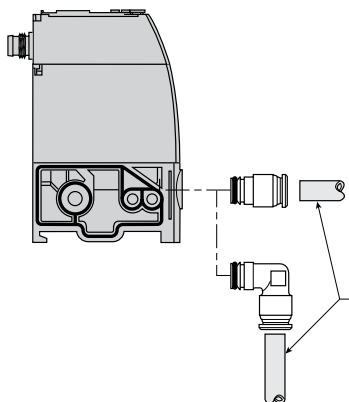

Fitting Assembly: Pneumatic Connectors are retained by a clip in each module. Assembly is achieved by pushing the fitting into the module and sliding the clip down over the groove in the fitting. Pull fitting to check that it is secure.

Tubing Assembly: Cut tubing squarely & cleanly. Inspect the tubing to insure there are no sharp edges that may nick or cut the o-ring seal. Insert tubing into fitting until it bottoms out. A slight pull on the tube afterwards can help verify it is properly retained / inserted.

Tubing Disassembly: When it is required to remove the tubing from the fitting push the release button in towards the fitting & remove the tubing.

Tubing Reassembly: Inspect the tubing before re-inserting it for any scoring or other damage that would affect the o-ring sealing. It is recommended that for every insertion, the tubing end be trimmed, especially if it has any scoring or damage.



Valve Module Solenoid Pilot 24VDC

Description	Weight	Part Number
Solenoid Pilot (Without Plug-in Electrical Connector)	0.53 oz	P2D8V32C5
Air Pilot with 5/32" (4mm) Tube Fitting	0.30 oz	P2M2K0PA



P2D8V32C5



P2M2K0PA

Size 1 Valve Modules Without Solenoid Pilot and Without Subbase



P2M1X4EE

4-Way / 2-Position / Single Valve

	Solenoid	Weight	Part Number
	Single Solenoid (Monostable)	0.92 oz	P2M1X4ES
	Double Solenoid (Bistable)	0.88 oz	P2M1X4EE

4-Way / 2-Position / Dual Valve

	Solenoid	Weight	Part Number
	Solenoid Spring with Exhaust Check	0.99 oz	P2M1XJEE

3-Way / 2-Position / Dual Valve

	Solenoid	Weight	Part Number
	Double Solenoid NC + NC with Exhaust Check	0.99 oz	P2M1XDEE
	Double Solenoid NO + NO with Exhaust Check	0.99 oz	P2M1XCEE
	Double Solenoid NC + NO with Exhaust Check	0.99 oz	P2M1XEEE
	Single Solenoid NC with Exhaust Check	0.88 oz	P2M1X3ES

Size 2 Valve Modules Without Solenoid Pilot and Without Subbase



P2M2X4EE

4-Way / 2-Position / Dual Valve

	Solenoid	Weight	Part Number
	Single Solenoid (Monostable)	0.99 oz	P2M2X4ES
	Double Solenoid (Bistable)	1.06 oz	P2M2X4EE

3-Way / 2-Position / Dual Valve

	Solenoid	Weight	Part Number
	Double Solenoid NC + NC with Exhaust Check	1.13 oz	P2M2XDEE
	Double Solenoid NO + NO with Exhaust Check	1.13 oz	P2M2XCEE
	Double Solenoid NC + NO with Exhaust Check	1.13 oz	P2M2XEEE
	Single Solenoid NC with Exhaust Check	0.99 oz	P2M2X3ES

Set of Maintenance Parts

Description		Part Number
Clips	Set of 10 Clips: 6 for Size 1 Modules, 2 for Size 2 Modules, 2 for Island Head and Intermediate Modules	P2M2K0CA
Seals	Set of 10 Seals: 3 for Inter Island Base Seals, 3 Under Solenoid Pilot Seals, 4 Under Valve Seals (Two Size 1 Seals, Two Size 2 Seals)	P2M2K0JA
Forks	Set of 10 Isolation Forks for Solenoid Pilot Manual Override	P2M2K0FA

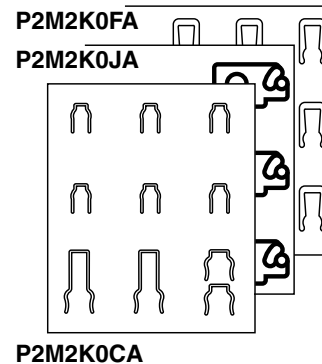



Pneumatic Valve Specifications

Fluid	Air, inert gas, filtered 40µ ¹ , dry ² or lubricated ³		
Operating Pressures	Vacuum to 120 PSI		
Piloting Pressure	43 to 120 PSI for operating pressures below, use external pilot supply available on all head modules ⁵		
Pilot Supply	Internal with "S" Series, mixed internal / external with "T" and "V" Series		
Exhaust Collection	All exhausts are collectable, including solenoid pilot exhaust		
Life Cycle	100 million operations ⁴ (with dry air, 3 Hz, 20°C, 6 bar)		
Operating Temperatures	5°F to 140°F (32°F to 130°F for field bus systems)		
Stocking Temperatures	-40°F to 155°F		
Vibration Resistance	According to IEC 68 - 2 - 6	2G	2 to 150 Hz
Impact Resistance	According to IEC 68 - 2 - 27	15G	11 ms

1. Class 5 according to ISO 8573-1
2. Class 4 according to ISO 8573-1
3. With main air supply lubricated, must use external pilot supply with non-lubricated air
4. 4/2 valve
5. Double 3/2 minimum 50 PSI

Electrical Specifications

Rated Coil Voltage	24VDC	
Allowable Voltage Fluctuation	-15% to +10 % of nominal voltage	
Electrical Connection	Polarity insensitive: PNP and NPN compatible	
Coil insulation Type	Class B	
Power Consumption	1W (42 mA)	
Manual Override	Locking or non-locking, isolated if required	
Response Time of the Complete Valve	9.6 ms ± 1.2 on 4/2 Double Solenoid Valve Size 1 12.0 ms ± 1.2 on 4/2 Single Solenoid Valve Size 1 14.8 ms ± 2 on 4/2 Double Solenoid Valve Size 2 17.0 ms ± 2 on 4/2 Single Solenoid Valve Size 2	According to ISO 12238
Type of Use	Continuous-duty Solenoid	
Dust and Water Protection	According to EN 60 529	"S" and "T" Series: IP67 "V" Series: IP65

Specifications for 1/4", 3/8" and 1/2" Fittings

Construction

Nickel Plated Brass Body; O-ring: Nitrile (Buna N) lubricated with Silicone lubricant; Grab Ring: 301 Stainless Steel; One Piece Button Collet: Acetal – black

Recommended Parker Tubing Series:

E (Linear Low Density Polyethylene), PP (Polypropylene), N (Plasticized Polyamide, Nylon), NR (Unplasticized Polyamide, Rigid Nylon), U (Polyurethane 90 Durometer Shore A), HU (Polyurethane 95 Durometer Shore A)

Other materials: Polyurethane 85 Durometer Shore A – Applications and service conditions vary and therefore the use of a tube support may be required for any 85A PU tubing. The following commercially available O.D. – I.D. 85A tubing sizes require the use of a tube support regardless of application. (5/32" – 3/32", 3/16" – 1/8", 1/4" - .170", 1/4" – 3/16", 5/16" – 1/4", 3/8" – 5/16", 1/2" – 3/8")

Prestolok fittings should not be used for live swivel applications. Vacuum applications dependent upon temperature and type of tubing used.

Specifications for 6mm, 8mm, 10mm, 12mm Fittings

Construction

Polyamide HR Body; O-ring: Nitrile (Buna N) lubricated with Silicone lubricant; Sleeve: Nickel Plate Brass; Grab Ring: 301 Stainless Steel; One Piece Button Collet: Polyacetal – yellow

Recommended Parker Tubing Series for 6mm, 8mm, 10mm, 12mm Fittings:

E (Linear Low Density Polyethylene), N (Plasticized Polyamide, Nylon), U (Polyurethane 90 Durometer Shore A), HU (Polyurethane 95 Durometer Shore A)

Prestolok fittings should not be used for live swivel applications. Vacuum applications dependent upon temperature and type of tubing used.



“S” Series Valve Island Dimensions and Mounting

Stand-Alone Valve Size 1



Stand-Alone Valve Size 2



Surface Mounting with Screws 4 mm Dia. into Retractable Brackets 3mm Thick

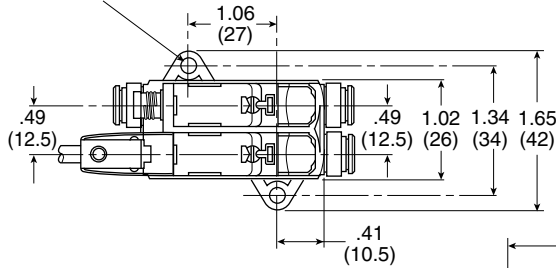

Surface Mounting with Screws 4 mm Dia. into Retractable Brackets 3mm Thick

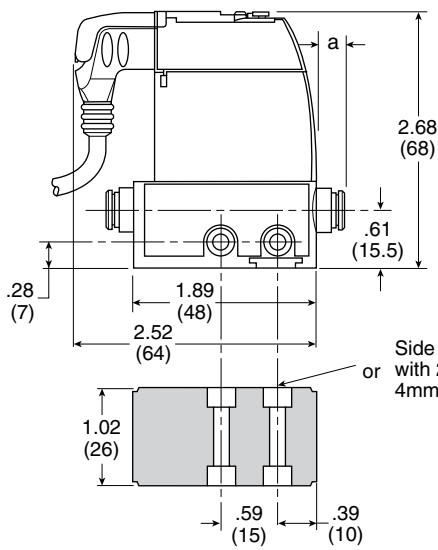
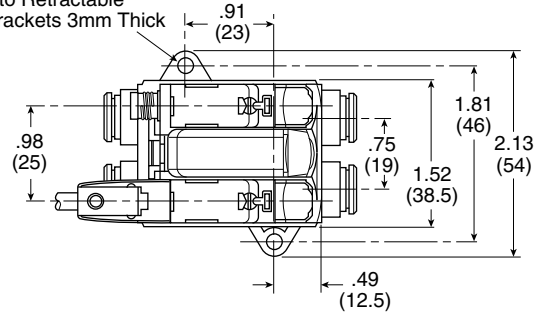

Size 1

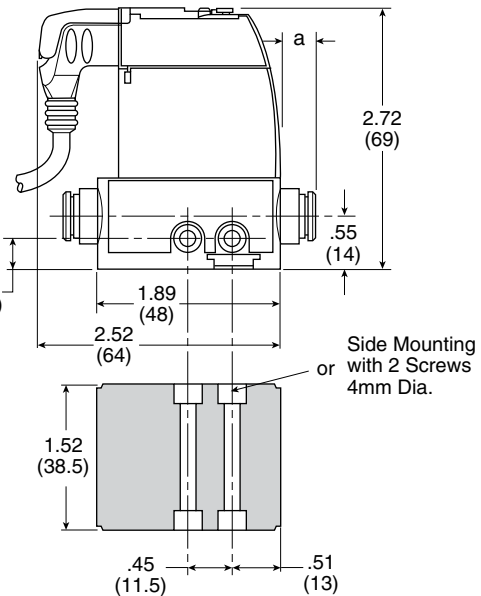
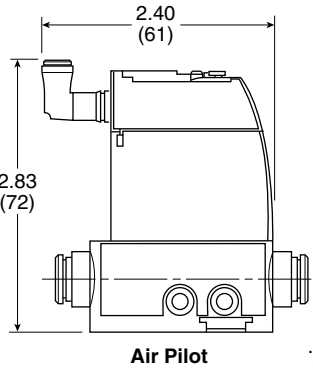

Size 2

		OD Tube Ext.	a	b	c
Size 1 Modules		5/32" (4 mm)	8	10	12
		6 mm	8	13	16
		1/4"	15	18	22
		Muffler		31	
Size 2 Modules		1/4"	12	18	22
		8 mm	9	16	19
		3/8"	16	23	26
		10 mm	13	18	22
		Muffler		40	

Special Case: 4/3 all ports blocked. Add the dual P.O. check valve module that has been plugged in the basic valve.

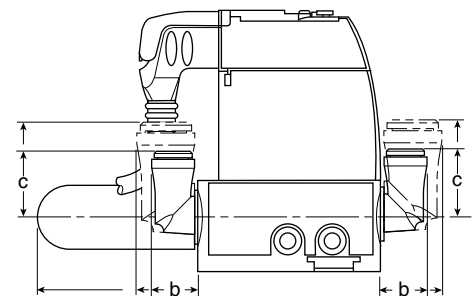



"T" Series Valve Island Dimensions and Mounting



Island Total Width Depends on Valve Composition

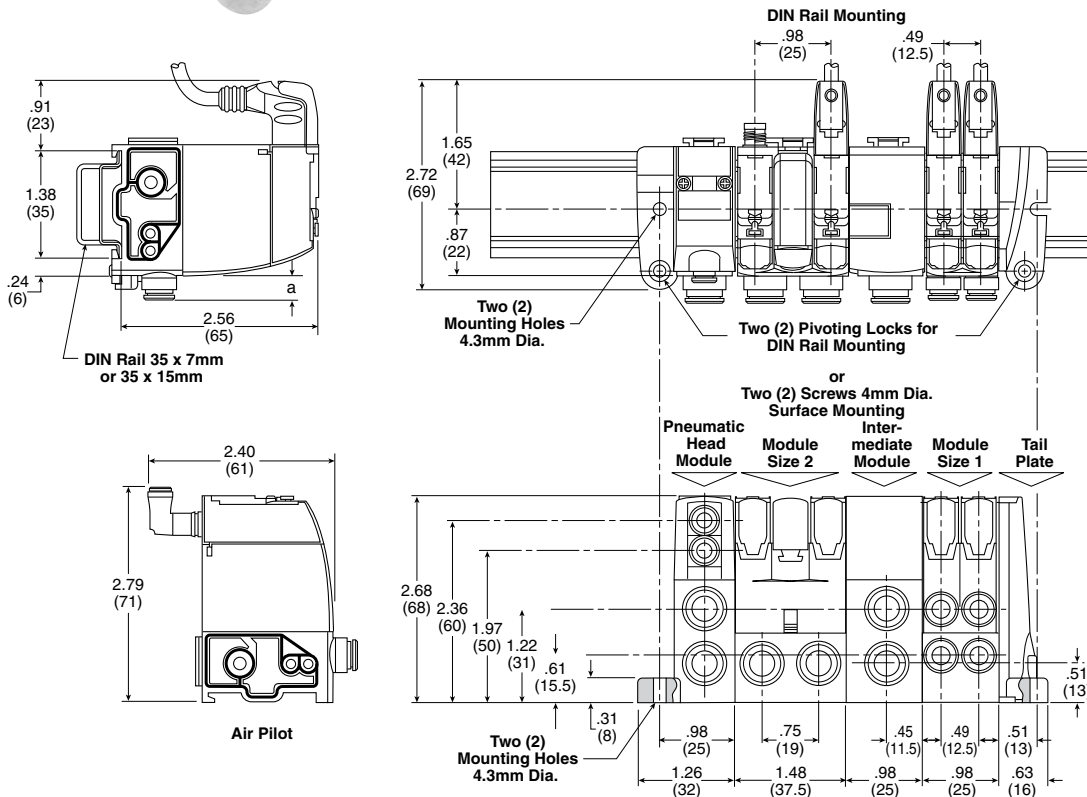

Special Case: 4/3 all ports blocked function within island version, add the dimensions of the dual P.O. check valve module plugged into the island.

Island Head and Intermediate Modules

	a	b	c
6 mm Tube OD	8	13	16
1/4" Tube OD	12	18	22
8 mm Tube OD	9	16	19
3/8" Tube OD	16	23	26
10 mm Tube OD	13	18	25
12 mm Tube OD	13	19	25
1/2" Tube OD	13		
Muffler		40	

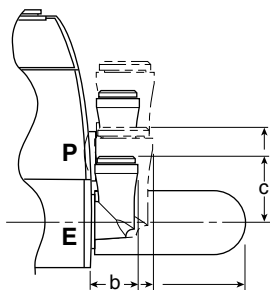

Island Valve Modules

OD Tube	Ext.	a	b	c
Size 1 Modules	5/32" (4 mm)	8	10	12
	6 mm	8	13	16
	1/4"	15	18	22
Size 2 Modules	1/4"	12	18	22
	8 mm	9	16	19
	3/8"	16	23	26
	10 mm	13	18	22

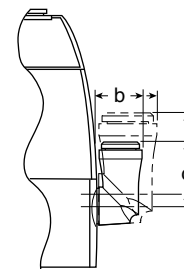



“V” Series Valve Island Dimensions and Mounting
20-Pin, Multi-Connector Valve Island



Island Total Width Depends on Valve Composition

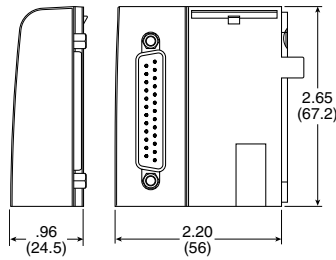
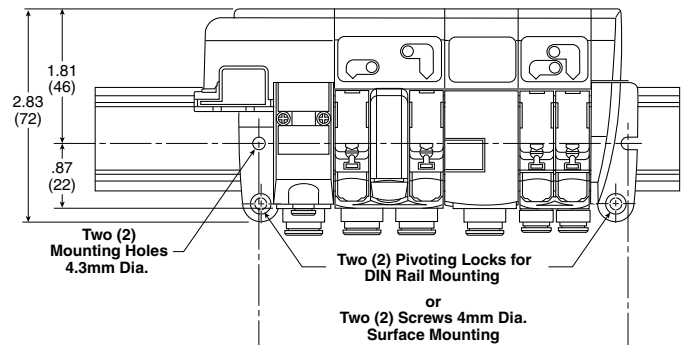
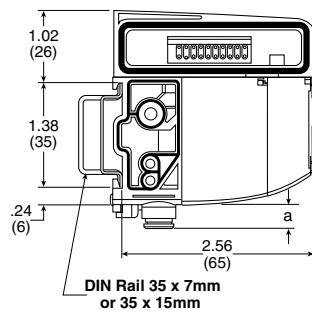

20-Pin, Multi-Connector

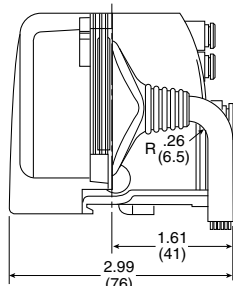

25-Pin, D-Sub Module

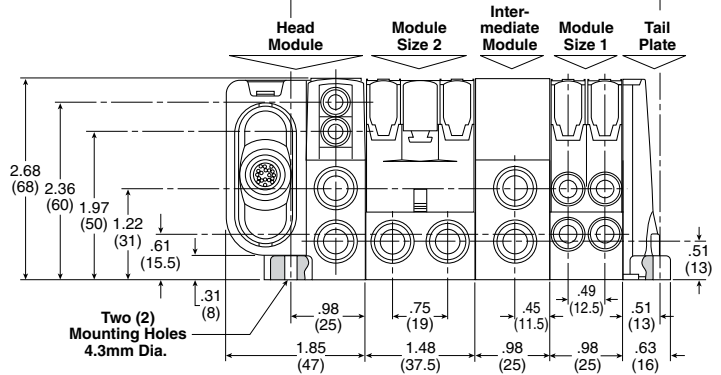

Island Head and Intermediate Modules

	a	b	c
6 mm Tube OD	8	13	16
1/4" Tube OD	12	18	22
8 mm Tube OD	9	16	19
3/8" Tube OD	16	23	26
10 mm Tube OD	13	18	25
12 mm Tube OD	13	19	25
1/2" Tube OD	13		
Muffler		40	

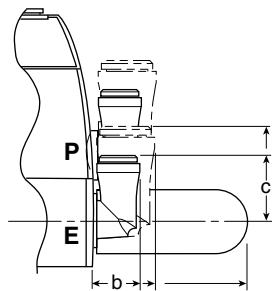

Island Valve Modules

OD Tube	Ext.	a	b	c
Size 1 Modules	5/32" (4 mm)	8	10	12
	6 mm	8	13	16
	1/4"	15	18	22
Size 2 Modules	1/4"	12	18	22
	8 mm	9	16	19
	3/8"	16	23	26
	10 mm	13	18	22

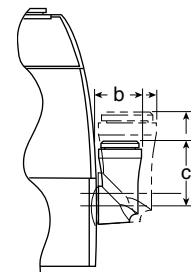



“V” Series Valve Island Dimensions and Mounting
Field Bus Connected Islands



Island Total Width
 Depends on Valve
 Composition

ASi Bus Islands

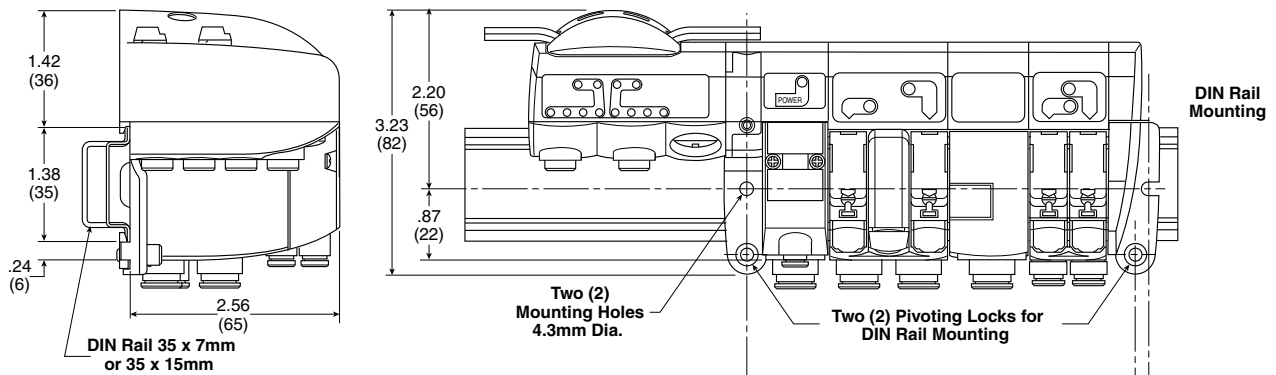

Device Bus Islands

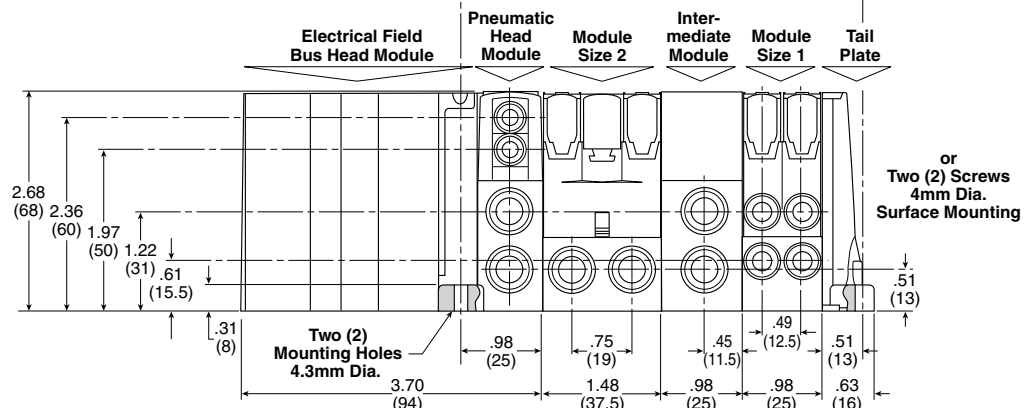
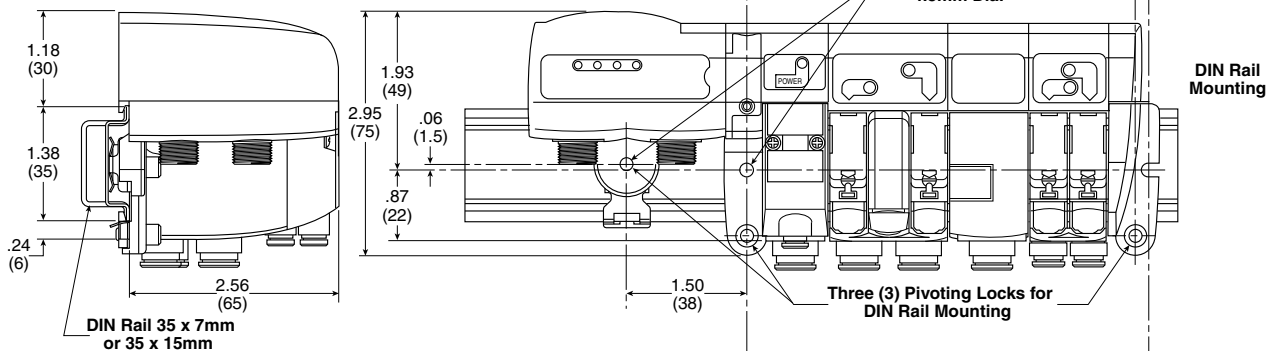



“P” Series Peripheral Modules Dimensions and Mounting

Reminder: Peripheral modules may either be plugged in the valve output ports or mounted in-line separate from the valve.

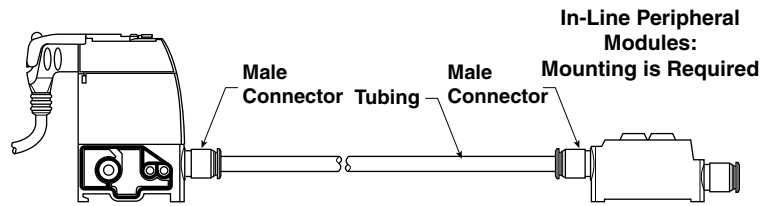
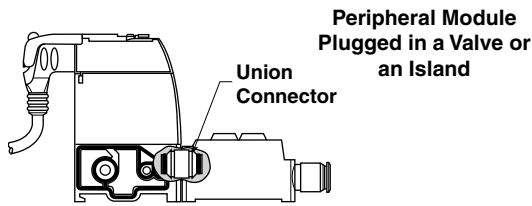

Dual Flow Control Module Size 1

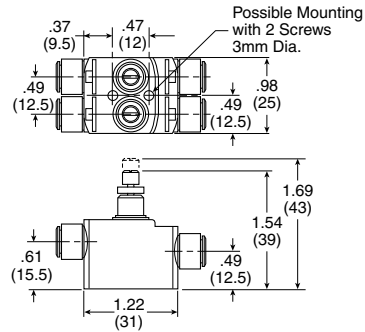
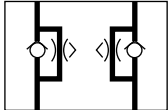

Pressure Regulation Module Size 1

With Gauge

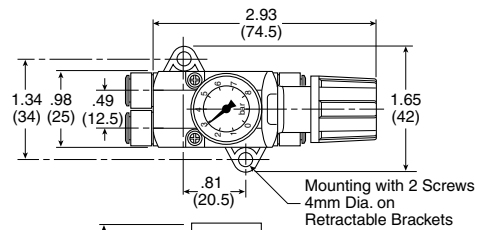
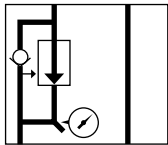

Without Gauge

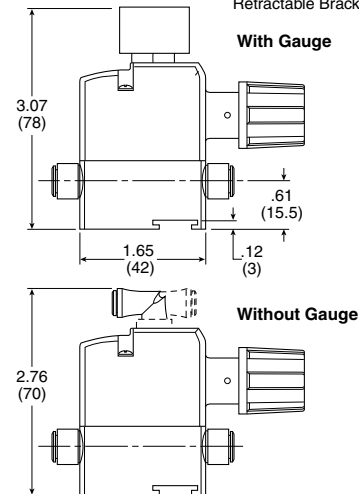
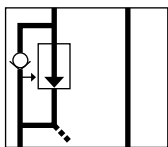

Dual P.O. Check Valve Module Size 1

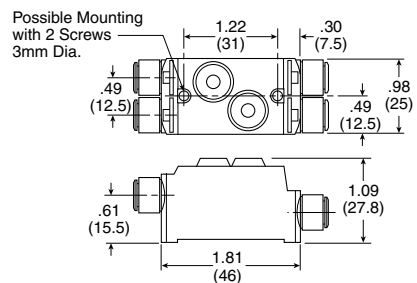
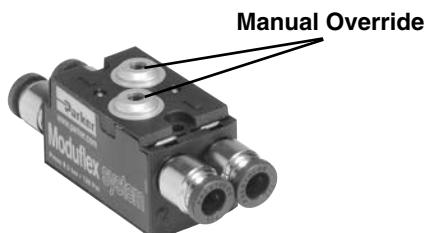
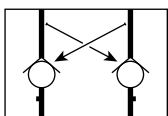



"P" Series Peripheral Modules Dimensions and Mounting

Reminder: Peripheral modules may either be plugged in the valve output ports or mounted in-line separate from the valve.

Vacuum Generator Size 1

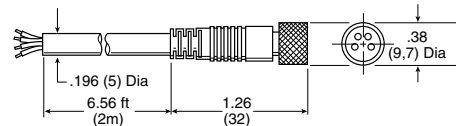
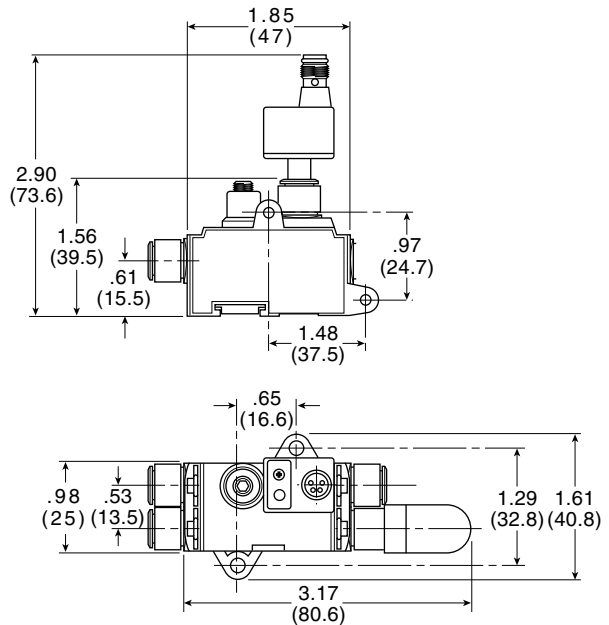
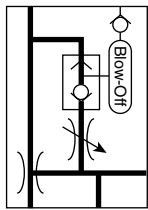

Sensor Pin Out

Pin #

- 1 Brown: 24VDC
- 2 White: NPN / PNP Open Collector Output
- 3 Blue: 0VDC
- 4 Black: NPN / PNP Open Collector Output

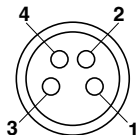

CB-M8-4P-5M, Female to Open Lead

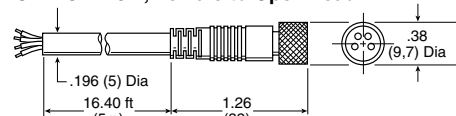

Sensor Specifications

Media	Air and Non-Corrosives Gases
Proof Pressure	(V) 72.5 PSI
Operating Temperature	32 to 122°F (0 to 50°C)
Storage Temperature	14 to 140°F (-10 to 60°C)
Humidity	35 to 85% RH
Electrical Connection	(C) 4-Pin, M8 Connector
Power Supply	10.8 to 30 VDC, Ripple Vp-p 10% max., Reverse Voltage Protection
Switch Output	1 Output Signal Open and Closed, NPN or PNP, 30VDC, 125mA
Linear Output	Analog Output 1 to 5 VDC
Switch Point Setting	2/3 Turn Trimmer
Hysteresis Setting	≤ 2% of F.S.
Output Response Time	<1ms
Repeatability	≤0.2% F.S.
Shock Resistance	100 G, XYZ
Material	Housing: Polycarbonate, Pressure Port: Zinc Die-cast
Mass	T Port: 0.25 oz. (7g)



“P” Series Peripheral Modules Dimensions and Mounting

Reminder: Peripheral modules may either be plugged in the valve output ports or mounted in-line separate from the valve.

Dual Flow Control Module Size 2

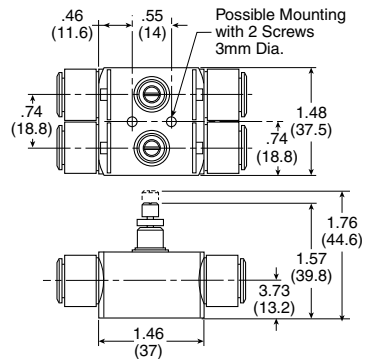
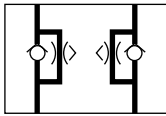

Pressure Regulation Module Size 2

With Gauge

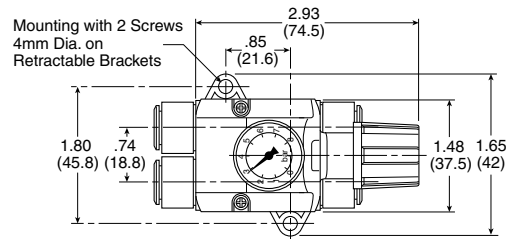
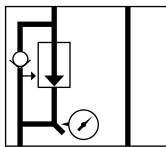

Without Gauge

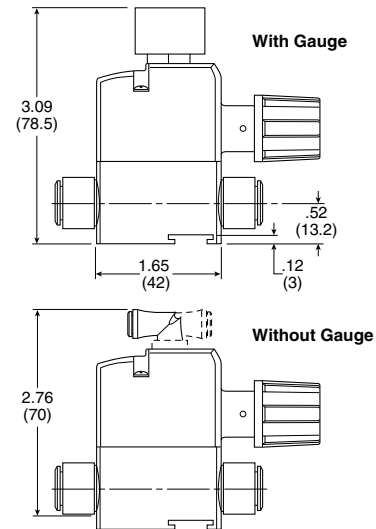
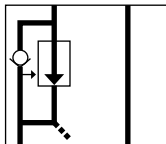

Dual P.O. Check Valve Module Size 2

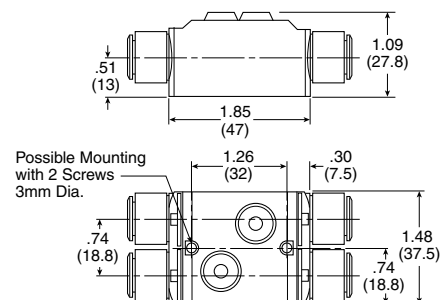
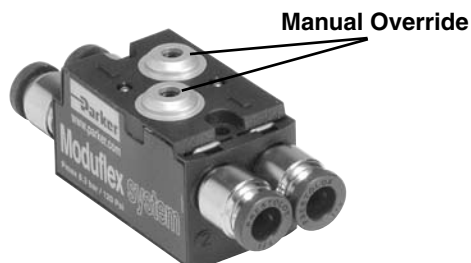
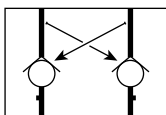



“V” or “T” Series Valve Island Configurator CD-ROM

Use CD-ROM “Standard Valve Island” Configuration

Valve Island Module Identification

Valve Island Graphic Description with Valve Module Symbols, Output Connectors, Pneumatic, and Electrical Head Module, etc....

Peripheral Module Additions

Valve Island Composition with Each Module Description and Order Code

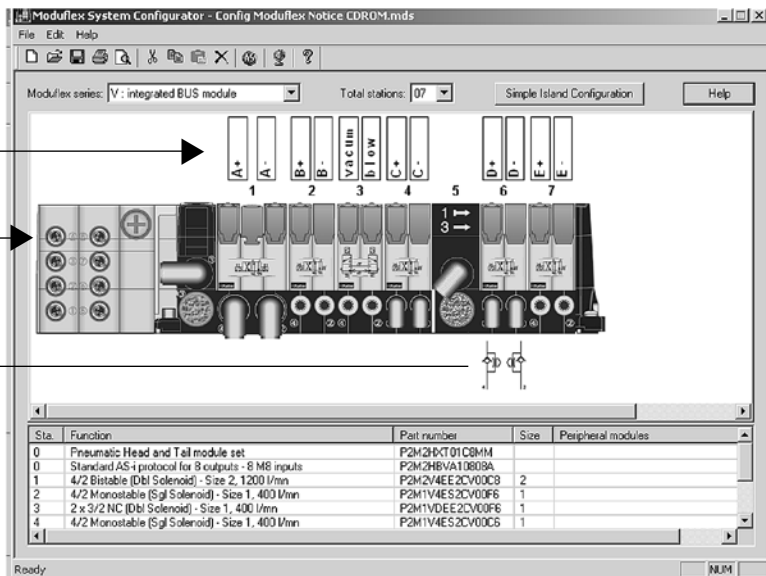

With the Moduflex Valve Island Configurator CD-ROM, you may configure the Moduflex V or T series valve islands that a given application requires.

With the CD-ROM, once the valve island is configured, the following items may be edited for the application:

1. Valve Island Print with Symbols and Marking

This graphic gathers all information required:

- For assembling, marking and connecting the valve island;
- For commissioning and maintaining the machine.

No additional valve circuit is necessary.

2. Report (4 pages) (1)

- Page 1 - Valve island complete modules part numbers
- Page 2 - Valve island basic modules and connectors listing
- Page 3 - Bill of material
- Page 4 - Warnings

3. 2D Drawings Exported DX File

This transfer on the machine drawings enables defining the valve island mounting onto the machine.

Note: 3D files (IGES, STEP and PRO-ENG) are available in the CD-ROM, for import in your CAD software of separate basic modules and connectors.

- (1) If an assembled valve island is ordered, please combine this 4-page report in order.

Valve Island Print with Symbols and Markings

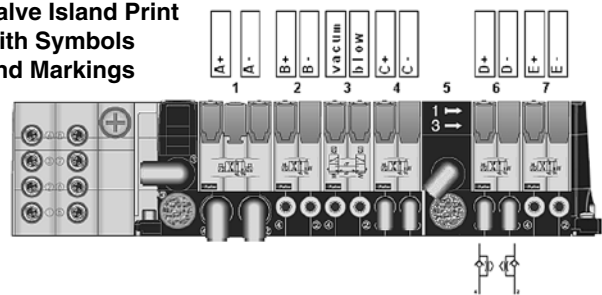

Valve Island 2D Drawing Exported DX File

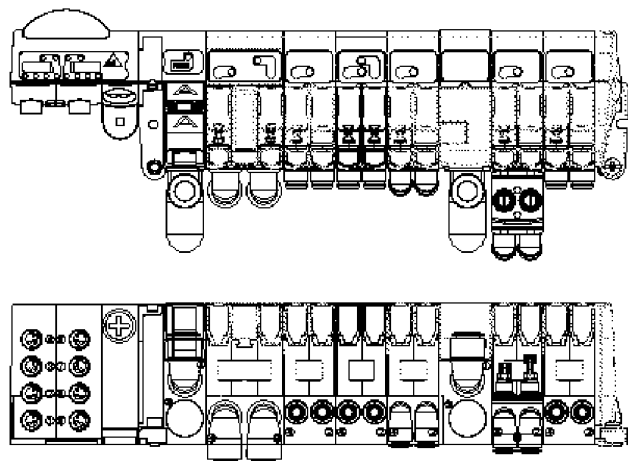



Ask for Your Moduflex Valve Island Configurator CD-ROM

Order Code: PDE2536CDV3.1-ev

This multi-language CD-ROM allows installation in English, French, German, Swedish, Italian and Spanish.





Safety Guide For Selecting And Using Pneumatic Division Products And Related Accessories

WARNING:

FAILURE OR IMPROPER SELECTION OR IMPROPER USE OF PNEUMATIC DIVISION PRODUCTS, ASSEMBLIES OR RELATED ITEMS ("PRODUCTS") CAN CAUSE DEATH, PERSONAL INJURY, AND PROPERTY DAMAGE. POSSIBLE CONSEQUENCES OF FAILURE OR IMPROPER SELECTION OR IMPROPER USE OF THESE PRODUCTS INCLUDE BUT ARE NOT LIMITED TO:

- Unintended or mistimed cycling or motion of machine members or failure to cycle
- Work pieces or component parts being thrown off at high speeds.
- Failure of a device to function properly for example, failure to clamp or unclamp an associated item or device.
- Explosion
- Suddenly moving or falling objects.
- Release of toxic or otherwise injurious liquids or gasses.

Before selecting or using any of these Products, it is important that you read and follow the instructions below.

1. GENERAL INSTRUCTIONS

- 1.1. Scope:** This safety guide is designed to cover general guidelines on the installation, use, and maintenance of Pneumatic Division Valves, FRLs (Filters, Pressure Regulators, and Lubricators), Vacuum products and related accessory components.
- 1.2. Fail-Safe:** Valves, FRLs, Vacuum products and their related components can and do fail without warning for many reasons. Design all systems and equipment in a fail-safe mode, so that failure of associated valves, FRLs or Vacuum products will not endanger persons or property.
- 1.3. Relevant International Standards:** For a good guide to the application of a broad spectrum of pneumatic fluid power devices see: ISO 4414:1998, Pneumatic Fluid Power – General Rules Relating to Systems. See www.iso.org for ordering information.
- 1.4. Distribution:** Provide a copy of this safety guide to each person that is responsible for selection, installation, or use of Valves, FRLs or Vacuum products. Do not select, or use Parker valves, FRLs or vacuum products without thoroughly reading and understanding this safety guide as well as the specific Parker publications for the products considered or selected.
- 1.5. User Responsibility:** Due to the wide variety of operating conditions and applications for valves, FRLs, and vacuum products Parker and its distributors do not represent or warrant that any particular valve, FRL or vacuum product is suitable for any specific end use system. This safety guide does not analyze all technical parameters that must be considered in selecting a product. The user, through its own analysis and testing, is solely responsible for:
 - Making the final selection of the appropriate valve, FRL, Vacuum component, or accessory.
 - Assuring that all user's performance, endurance, maintenance, safety, and warning requirements are met and that the application presents no health or safety hazards.
 - Complying with all existing warning labels and / or providing all appropriate health and safety warnings on the equipment on which the valves, FRLs or Vacuum products are used; and,
 - Assuring compliance with all applicable government and industry standards.
- 1.6. Safety Devices:** Safety devices should not be removed, or defeated.
- 1.7. Warning Labels:** Warning labels should not be removed, painted over or otherwise obscured.
- 1.8. Additional Questions:** Call the appropriate Parker technical service department if you have any questions or require any additional information. See the Parker publication for the product being considered or used, or call 1-800-CPARKER, or go to www.parker.com, for telephone numbers of the appropriate technical service department.

2. PRODUCT SELECTION INSTRUCTIONS

- 2.1. Flow Rate:** The flow rate requirements of a system are frequently the primary consideration when designing any pneumatic system. System components need to be able to provide adequate flow and pressure for the desired application.
- 2.2. Pressure Rating:** Never exceed the rated pressure of a product. Consult product labeling, Pneumatic Division catalogs or the instruction sheets supplied for maximum pressure ratings.
- 2.3. Temperature Rating:** Never exceed the temperature rating of a product. Excessive heat can shorten the life expectancy of a product and result in complete product failure.
- 2.4. Environment:** Many environmental conditions can affect the integrity and suitability of a product for a given application. Pneumatic Division products are designed for use in general purpose industrial applications. If these products are to be used in unusual circumstances such as direct sunlight and/or corrosive or caustic environments, such use can shorten the useful life and lead to premature failure of a product.
- 2.5. Lubrication and Compressor Carryover:** Some modern synthetic oils can and will attack nitrile seals. If there is any possibility of synthetic oils or greases migrating into the pneumatic components check for compatibility with the seal materials used. Consult the factory or product literature for materials of construction.
- 2.6. Polycarbonate Bowls and Sight Glasses:** To avoid potential polycarbonate bowl failures:
 - Do not locate polycarbonate bowls or sight glasses in areas where they could be subject to direct sunlight, impact blow, or temperatures outside of the rated range.
 - Do not expose or clean polycarbonate bowls with detergents, chlorinated hydro-carbons, ketones, esters or certain alcohols.
 - Do not use polycarbonate bowls or sight glasses in air systems where compressors are lubricated with fire resistant fluids such as phosphate ester and di-ester lubricants.



- 2.7. Chemical Compatibility:** For more information on plastic component chemical compatibility see Pneumatic Division technical bulletins Tec-3, Tec-4, and Tec-5
- 2.8. Product Rupture:** Product rupture can cause death, serious personal injury, and property damage.
- Do not connect pressure regulators or other Pneumatic Division products to bottled gas cylinders.
 - Do not exceed the maximum primary pressure rating of any pressure regulator or any system component.
 - Consult product labeling or product literature for pressure rating limitations.

3. PRODUCT ASSEMBLY AND INSTALLATION INSTRUCTIONS

- 3.1. Component Inspection:** Prior to assembly or installation a careful examination of the valves, FRLs or vacuum products must be performed. All components must be checked for correct style, size, and catalog number. DO NOT use any component that displays any signs of nonconformance.
- 3.2. Installation Instructions:** Parker published Installation Instructions must be followed for installation of Parker valves, FRLs and vacuum components. These instructions are provided with every Parker valve or FRL sold, or by calling 1-800-CPARKER, or at www.parker.com.
- 3.3. Air Supply:** The air supply or control medium supplied to Valves, FRLs and Vacuum components must be moisture-free if ambient temperature can drop below freezing

4. VALVE AND FRL MAINTENANCE AND REPLACEMENT INSTRUCTIONS

- 4.1. Maintenance:** Even with proper selection and installation, valve, FRL and vacuum products service life may be significantly reduced without a continuing maintenance program. The severity of the application, risk potential from a component failure, and experience with any known failures in the application or in similar applications should determine the frequency of inspections and the servicing or replacement of Pneumatic Division products so that products are replaced before any failure occurs. A maintenance program must be established and followed by the user and, at minimum, must include instructions 4.2 through 4.10.
- 4.2. Installation and Service Instructions:** Before attempting to service or replace any worn or damaged parts consult the appropriate Service Bulletin for the valve or FRL in question for the appropriate practices to service the unit in question. These Service and Installation Instructions are provided with every Parker valve and FRL sold, or are available by calling 1-800-CPARKER, or by accessing the Parker web site at www.parker.com.
- 4.3. Lockout / Tagout Procedures:** Be sure to follow all required lockout and tagout procedures when servicing equipment. For more information see: OSHA Standard – 29 CFR, Part 1910.147, Appendix A, The Control of Hazardous Energy – (Lockout / Tagout)
- 4.4. Visual Inspection:** Any of the following conditions requires immediate system shut down and replacement of worn or damaged components:
- Air leakage: Look and listen to see if there are any signs of visual damage to any of the components in the system. Leakage is an indication of worn or damaged components.
 - Damaged or degraded components: Look to see if there are any visible signs of wear or component degradation.
 - Kinked, crushed, or damaged hoses. Kinked hoses can result in restricted air flow and lead to unpredictable system behavior.
 - Any observed improper system or component function: Immediately shut down the system and correct malfunction.
 - Excessive dirt build-up: Dirt and clutter can mask potentially hazardous situations.

Caution: Leak detection solutions should be rinsed off after use.

- 4.5. Routine Maintenance Issues:**
- Remove excessive dirt, grime and clutter from work areas.
 - Make sure all required guards and shields are in place.
- 4.6. Functional Test:** Before initiating automatic operation, operate the system manually to make sure all required functions operate properly and safely.
- 4.7. Service or Replacement Intervals:** It is the user's responsibility to establish appropriate service intervals. Valves, FRLs and vacuum products contain components that age, harden, wear, and otherwise deteriorate over time. Environmental conditions can significantly accelerate this process. Valves, FRLs and vacuum components need to be serviced or replaced on routine intervals. Service intervals need to be established based on:
- Previous performance experiences.
 - Government and / or industrial standards.
 - When failures could result in unacceptable down time, equipment damage or personal injury risk.
- 4.8. Servicing or Replacing of any Worn or Damaged Parts:** To avoid unpredictable system behavior that can cause death, personal injury and property damage:
- Follow all government, state and local safety and servicing practices prior to service including but not limited to all OSHA Lockout Tagout procedures (OSHA Standard – 29 CFR, Part 1910.147, Appendix A, The Control of Hazardous Energy – Lockout / Tagout).
 - Disconnect electrical supply (when necessary) before installation, servicing, or conversion.
 - Disconnect air supply and depressurize all air lines connected to system and Pneumatic Division products before installation, service, or conversion.
 - Installation, servicing, and / or conversion of these products must be performed by knowledgeable personnel who understand how pneumatic products are to be applied.
 - After installation, servicing, or conversions air and electrical supplies (when necessary) should be connected and the product tested for proper function and leakage. If audible leakage is present, or if the product does not operate properly, do not put product or system into use.
 - Warnings and specifications on the product should not be covered or painted over. If masking is not possible, contact your local representative for replacement labels.
- 4.9. Putting Serviced System Back into Operation:** Follow the guidelines above and all relevant Installation and Maintenance Instructions supplied with the valve FRL or vacuum component to insure proper function of the system.





The items described in this document and other documents or descriptions provided by Parker Hannifin Corporation, its subsidiaries and its authorized distributors, are hereby offered for sale at prices to be established by Parker Hannifin Corporation, its subsidiaries and its authorized distributors. This offer and its acceptance by any customer ("Buyer") shall be governed by all of the following Terms and Conditions. Buyer's order for any such item, when communicated to Parker Hannifin Corporation, its subsidiaries or an authorized distributor ("Seller") verbally or in writing, shall constitute acceptance of this offer.

1. Terms and Conditions of Sale: All descriptions, quotations, proposals, offers, acknowledgments, acceptances and sales of Seller's products are subject to and shall be governed exclusively by the terms and conditions stated herein. Buyer's acceptance of any offer to sell is limited to these terms and conditions. Any terms or conditions in addition to, or inconsistent with those stated herein, proposed by Buyer in any acceptance of an offer by Seller, are hereby objected to. No such additional, different or inconsistent terms and conditions shall become part of the contract between Buyer and Seller unless expressly accepted in writing by Seller. Seller's acceptance of any offer to purchase by Buyer is expressly conditional upon Buyer's assent to all the terms and conditions stated herein, including any terms in addition to, or inconsistent with those contained in Buyer's offer. Acceptance of Seller's products shall in all events constitute such assent.

2. Payment: Payment shall be made by Buyer net 30 days from the date of delivery of the items purchased hereunder. Amounts not timely paid shall bear interest at the maximum rate permitted by law for each month or portion thereof that the Buyer is late in making payment. Any claims by Buyer for omissions or shortages in a shipment shall be waived unless Seller receives notice thereof within 30 days after Buyer's receipt of the shipment.

3. Delivery: Unless otherwise provided on the face hereof, delivery shall be made F.O.B. Seller's plant. Regardless of the method of delivery, however, risk of loss shall pass to Buyer upon Seller's delivery to a carrier. Any delivery dates shown are approximate only and Seller shall have no liability for any delays in delivery.

4. Warranty: Seller warrants that the items sold hereunder shall be free from defects in material or workmanship for a period of 18 months from date of shipment from Parker Hannifin Corporation. THIS WARRANTY COMPRISES THE SOLE AND ENTIRE WARRANTY PERTAINING TO ITEMS PROVIDED HEREUNDER. SELLER MAKES NO OTHER WARRANTY, GUARANTEE, OR REPRESENTATION OF ANY KIND WHATSOEVER. ALL OTHER WARRANTIES, INCLUDING BUT NOT LIMITED TO, MERCHANTABILITY AND FITNESS FOR PURPOSE, WHETHER EXPRESS, IMPLIED, OR ARISING BY OPERATION OF LAW, TRADE USAGE, OR COURSE OF DEALING ARE HEREBY DISCLAIMED.

NOTWITHSTANDING THE FOREGOING, THERE ARE NOWARRANTIES WHATSOEVER ON ITEMS BUILT OR ACQUIRED WHOLLY OR PARTIALLY, TO BUYER'S DESIGN OR SPECIFICATIONS.

5. Limitation of Remedy: SELLER'S LIABILITY ARISING FROM OR IN ANY WAY CONNECTED WITH THE ITEMS SOLD OR THIS CONTRACT SHALL BE LIMITED EXCLUSIVELY TO REPAIR OR REPLACEMENT OF THE ITEMS SOLD OR REFUND OF THE PURCHASE PRICE PAID BY BUYER, AT SELLER'S SOLE OPTION. IN NO EVENT SHALL SELLER BE LIABLE FOR ANY INCIDENTAL, CONSEQUENTIAL OR SPECIAL DAMAGES OF ANY KIND OR NATURE WHATSOEVER, INCLUDING BUT NOT LIMITED TO LOST PROFITS ARISING FROM OR IN ANY WAY CONNECTED WITH THIS AGREEMENT OR ITEMS SOLD HEREUNDER, WHETHER ALLEGED TO ARISE FROM BREACH OF CONTRACT, EXPRESS OR IMPLIED WARRANTY, OR IN TORT, INCLUDING WITHOUT LIMITATION, NEGLIGENCE, FAILURE TO WARN OR STRICT LIABILITY.

6. Changes, Reschedules and Cancellations: Buyer may request to modify the designs or specifications for the items sold hereunder as well as the quantities and delivery dates thereof, or may request to cancel all or part of this order, however, no such requested modification or cancellation shall become part of the contract between Buyer and Seller unless accepted by Seller in a written amendment to this Agreement. Acceptance of any such requested modification or cancellation shall be at Seller's discretion, and shall be upon such terms and conditions as Seller may require.

7. Special Tooling: A tooling charge may be imposed for any special tooling, including without limitations, dies, fixtures, molds and patterns, acquired to manufacture items sold pursuant to this contract. Such special tooling shall be and remain Seller's property notwithstanding payment of any charges by Buyer. In no event will Buyer acquire any interest in apparatus belonging to Seller which is utilized in the manufacture of the items sold hereunder, even if such apparatus has been specially converted or adapted for such manufacture and notwithstanding any

charges paid by Buyer. Unless otherwise agreed, Seller shall have the right to alter, discard or otherwise dispose of any special tooling or other property in its sole discretion at any time.

8. Buyer's Property: Any designs, tools, patterns, materials, drawings, confidential information or equipment furnished by Buyer, or any other items which become Buyer's property, may be considered obsolete and may be destroyed by Seller after two (2) consecutive years have elapsed without Buyer placing an order for the items which are manufactured using such property. Seller shall not be responsible for any loss or damage to such property while it is in Seller's possession or control.

9. Taxes: Unless otherwise indicated on the face hereof, all prices and charges are exclusive of excise, sales, use, property, occupational or like taxes which may be imposed by any taxing authority upon the manufacture, sale or delivery of the items sold hereunder. If any such taxes must be paid by Seller or if Seller is liable for the collection of such tax, the amount thereof shall be in addition to the amounts for the items sold. Buyer agrees to pay all such taxes or to reimburse Seller therefore upon receipt of its invoice. If Buyer claims exemption from any sales, use or other tax imposed by any taxing authority, Buyer shall save Seller harmless from and against any such tax, together with any interest or penalties thereon which may be assessed if the items are held to be taxable.

10. Indemnity For Infringement of Intellectual Property Rights: Seller shall have no liability for infringement of any patents, trademarks, copyrights, trade dress, trade secrets or similar rights except as provided in this Part 10. Seller will defend and indemnify Buyer against allegations of infringement of U.S. patents, U.S. trademarks, copyrights, trade dress and trade secrets (hereinafter "Intellectual Property Rights"). Seller will defend at its expense and will pay the cost of any settlement or damages awarded in an action brought against Buyer based on an allegation that an item sold pursuant to this contract infringes the Intellectual Property Rights of a third party. Seller's obligation to defend and indemnify Buyer is contingent on Buyer notifying Seller within ten (10) days after Buyer becomes aware of such allegations of infringement, and Seller having sole control over the defense of any allegations or actions including all negotiations for settlement or compromise. If an item sold hereunder is subject to a claim that it infringes the Intellectual Property Rights of a third party, Seller may, at its sole expense and option, procure for Buyer the right to continue using said item, replace or modify said item so as to make it noninfringing, or offer to accept return of said item and return the purchase price less a reasonable allowance for depreciation. Notwithstanding the foregoing, Seller shall have no liability for claims of infringement based on information provided by Buyer, or directed to items delivered hereunder for which the designs are specified in whole or part by Buyer, or infringements resulting from the modification, combination or use in a system of any item sold hereunder. The foregoing provisions of this Part 10 shall constitute Seller's sole and exclusive liability and Buyer's sole and exclusive remedy for infringement of Intellectual Property Rights.

If a claim is based on information provided by Buyer or if the design for an item delivered hereunder is specified in whole or in part by Buyer, Buyer shall defend and indemnify Seller for all costs, expenses or judgements resulting from any claim that such item infringes any patent, trademark, copyright, trade dress, trade secret or any similar right.

11. Force Majeure: Seller does not assume the risk of and shall not be liable for delay or failure to perform any of Seller's obligations by reason of circumstances beyond the reasonable control of Seller (hereinafter "Events of Force Majeure"). Events of Force Majeure shall include without limitation, accidents, acts of God, strikes or labor disputes, acts, laws, rules or regulations of any government or government agency, fires, floods, delays or failures in delivery of carriers or suppliers, shortages of materials and any other cause beyond Seller's control.

12. Entire Agreement/Governing Law: The terms and conditions set forth herein, together with any amendments, modifications and any different terms or conditions expressly accepted by Seller in writing, shall constitute the entire Agreement concerning the items sold, and there are no oral or other representations or agreements which pertain thereto. This Agreement shall be governed in all respects by the law of the State of Ohio. No actions arising out of sale of the items sold hereunder or this Agreement may be brought by either party more than two (2) years after the cause of action accrues.



Parker Hannifin Corporation

Pneumatic Division
8676 E. M89
P.O. Box 901
Richland, MI 49083 USA
Tel: (269) 629-5000
Fax: (269) 629-5385

Customer/Technical Service

Tel: (269) 629-5575
Fax: (269) 629-5385
Web site: www.parker.com/pneumatics
E-mail: PDNMKTG@parker.com