



aerospace  
climate control  
electromechanical  
filtration  
fluid & gas handling  
hydraulics  
pneumatics  
process control  
sealing & shielding



# Filtration Innovations

Filters for Vacuum Pumps



ENGINEERING YOUR SUCCESS.

# Parker Hannifin - Filtration and Separation

---

## Compressed Air Treatment

Superior protection from the damaging and costly effects of oil, water and dirt...

- Filter elements that offer both market leading performance and efficiency and are environmentally friendly in their manufacture and disposal.
- Housings ranging from 1/4" to DN200 coded vessels, together with a full range of drain and differential pressure gauge options.
- A wide range of filtration efficiencies to provide the exact filtration that's required. From bulk water separation through to bacteria removal for sterile air.
- Innovative membrane air dryers that provide clean dry air with dew points down to -40°C, without any moving parts or the requirement for additional power.
- The inherent advantages of Parker filter elements are available in a range of filter elements sized to fit other manufacturers housings, offering the opportunity to upgrade to a Parker filter.
- Request catalogue S3.2.111

## Gas Filtration

Filtration for sampling systems, analyser applications and process gases providing protection - pure and simple...

- Remove liquids & solids from gases with up to 99.9999+% efficiency at 0.01 µm.
- Specially configured filter media for applications such as carbon dioxide purification, alternative fuels and steam filtration.
- Temperature resistance to 538°C and a maximum pressure of 345 barg.
- Low pressure drop and a long life between filter element changes.
- Request catalogue S3.2.206

## Process Liquid Filtration

Process liquid filtration providing purification and clarification for the beverage, chemical processing, cosmetic, food processing, metalworking, paint, ink, pharmaceutical and water treatment industries...

- Parker's line of membrane cartridges is ideal for critical applications where high performance is required.
- Parker's pleated depth filter series of cartridges provide high flow long life filtration, including absolute and nominal rated cartridges available in polypropylene, microglassfibre and cellulose.
- Wound Depth, Resin Bonded and Melt Blown filter cartridge series from Parker together with Filter Bag Media, Strainers, Metallic Media and Sorbent Media providing a range of choices to ensure the correct filtration for your application.
- Parker coded and non-coded vessels available for a broad range of applications.
- Request catalogue S3.2.243

## On-Site Nitrogen Generators

Nitrogen is the most widely used gas in industry since it can prevent the risk of explosion or stop product degradation. Nitrogen is being used in new and exciting applications such as tyre filling for cars, motorcycles and trucks...

- Parker's proprietary hollow fibre membrane technology simply and elegantly separates nitrogen from compressed air.
- Generators such as the NitroSource will provide a supply of nitrogen from house compressed air, whilst units such as the NitroFlow® wall mount provide a plug-and-play solution with the inclusion of an integrated compressor.
- Request catalogue K3.1.183

# Contents

---

<b>Parker Filtration</b> .....	2
<b>Vacuum Pump Inlet Filters for Vacuum Service to 10<sup>-6</sup> Torr</b> .....	4
<b>Vacuum Pump Inlet Filters for Vacuum Service to 2 Torr</b> .....	5
<b>Vacuum Pump Exhaust Filters for Non-Hazardous/Non-Corrosive Applications</b> .....	6
<b>Vacuum Pump Exhaust Filters for Hazardous/Corrosive Applications</b> .....	8

## Recommended Exhaust Filters for Vacuum Pumps

Alcatel Pumps.....	9	Quincy Pumps.....	18
Balzers Pumps .....	9	Rietschle Pumps.....	18
Beach-Russ Pumps .....	10	RO-FLO Pumps (Allis-Chalmers) .....	19
Busch Pumps .....	10	Sargent-Welch Pumps .....	19
Central Scientific Pumps (Cenco, Boekel, HYVAC) .....	12	Stokes Pumps.....	20
Edwards High Vacuum Pumps .....	13	Ulvac Pumps.....	20
Gast Pumps .....	13	Varian Pumps .....	20
Hitachi.....	14	<b>Pump to Filter Adaptors</b> .....	21
Ingersoll-Rand Pumps.....	15	<b>What is a Vacuum Pump?</b> .....	22
ITT Pneumotive (Leiman Brothers) .....	15		
Kinney Pumps.....	15		
Lammert Pumps .....	16		
Leybold Heraeus.....	16		
Marvac Pumps .....	17		
Maxima Pumps (Fisher Scientific).....	17		
Precision Scientific Pumps .....	17		

# Vacuum Pump Inlet Filters for Vacuum Service to 10<sup>-6</sup> Torr

## Benefits

Protect vacuum pumps from damage by solids and liquids

Prevent loss of valuable or hazardous materials

Prevent oil backstreaming

## Model CF-0112 and CF-0118 for Vacuum Service to 10<sup>-6</sup> Torr

Stainless steel housings with welded KF flange inlet and outlet ports and no drain ports. They are designed to be used primarily with the Grade 102 adsorbent cartridges for prevention of oil backstreaming (see cartridge selection chart below). They may also be used with Grade 30 cartridges for removal of high concentrations of solids, but the absence of drain ports precludes the use of CF housings for liquid removal in vacuum applications.



CF-0118-30

## Filter Selection Chart

Grade 30 Cartridges	For removal of relatively high concentrations of solids
<b>Efficiency:</b>	90% at 0.1 micron
<b>Loss in Pumping Speed:</b>	9% at maximum flow rate
<b>Materials of Construction:</b>	Polypropylene cartridge, EPR seals
<b>Maximum Temperature:</b>	82°C (180°F)
Grade 102 Cartridges	For prevention of oil backstreaming and filtration of relatively low concentrations of solids
<b>Efficiency for Preventing Oil Backstreaming:</b>	99.99%
<b>Life:</b>	Approximately 1,000 hours at 10 microns vacuum
<b>Efficiency for Solids Filtration:</b>	99.99% at 0.1 micron
<b>Materials of Construction:</b>	Molecular Sieve Type 4A adsorbent, EPR seals
<b>Maximum Temperature:</b>	38°C (100°F)

## Principal Specifications

Model	CF-0112	CF-0118
<b>Recommended Vacuum Service</b>	10 <sup>-6</sup> Torr	10 <sup>-6</sup> Torr
<b>Max. Flow Rating of Vacuum Pump</b>	5 m <sup>3</sup> /hr (3 CFM)	15 m <sup>3</sup> /hr (9 CFM)
<b>Inlet and Outlet Ports</b>	KF-25	KF-25
<b>Materials of Construction:</b>		
<b>Head</b>	304 SS	304 SS
<b>Bowl</b>	304 SS	304 SS
<b>Internals</b>	304 SS	304 SS
<b>Seals</b>	None	None
<b>Maximum Temperature</b>	82°C (180°F) <sup>(1)</sup>	82°C (180°F) <sup>(1)</sup>
<b>Shipping Weight</b>	0.2 kg	0.4 kg
<b>Dimensions</b>	70 x 110 mm	100 x 150 mm

### Notes:

1 Maximum temperature grade 102 Cartridge is 38°C (100°F).

2 Filter Cartridge is permanently sealed into housing. The entire unit is disposable.

## Ordering Information

Assembly with Grade 30 Particulate Filter	Assembly with Grade 102 Backstreaming Filter
CF-0112-30	CF-0112-102
CF-0118-30	CF-0118-102

# Vacuum Pump Inlet Filters for Vacuum Service to 2 Torr

## Benefits

- Protect vacuum pumps from damage by solids and liquids
- Prevent loss of valuable or hazardous materials
- Prevent oil backstreaming

## Models CV-0112-30 and CV-0118-30 for hazardous/corrosive applications and low flow applications

Stainless steel housings with NPT inlet, outlet and drain ports. Used only with Grade 30 filter cartridges.

## Model 18/18-30 for non-hazardous/non-corrosive applications and higher flow applications

Steel housing with NPT inlet, outlet and drain ports. Used only with Grade 30 filter cartridges.



18/18-30

## Filter Selection Chart

Grade 30 Cartridges	For removal of relatively high concentrations of solids and liquids
<b>Efficiency:</b>	90% at 0.1 micron
<b>Loss in Pumping Speed:</b>	9% at maximum flow rate
<b>Materials of Construction:</b>	Polypropylene cartridge, EPR seals
<b>Maximum Temperature:</b>	82°C (180°F)

## Principal Specifications

Model	CV-0112-30	CV-0118-30	18/18-30
<b>Recommended Vacuum Service</b>	2 Torr	2 Torr	2 Torr
<b>Max. Flow Rating of Vacuum Pump</b>	5 m <sup>3</sup> /hr (3 CFM)	15 m <sup>3</sup> /hr (9 CFM)	15 m <sup>3</sup> /hr (9CFM) <sup>(1)</sup>
<b>Inlet and Outlet Ports</b>	1/2" NPT	3/4" NPT	3/4" NPT
<b>Drain Port <sup>(2)</sup></b>	1/8" NPT	1/8" NPT	1/8" NPT
<b>Materials of Construction</b>			
<b>Head</b>	304 SS	304 SS	Steel
<b>Bowl</b>	304 SS	304 SS	Steel
<b>Internals</b>	304 SS	304 SS	Steel
<b>Seals</b>	None	None	None
<b>Maximum Temperature</b>	82°C (180°F)	82°C (180°F)	82°C (180°F)
<b>Shipping Weight</b>	0.2 kg	0.4 kg	1 kg
<b>Dimensions</b>	70 x 110 mm	100 x 150 mm	100 x 140 mm

## Ordering Information

Assembly with Grade 30 Particulate Filter
CV-0112-30
CV-0118-30
18/18-30

### Notes:

- <sup>1</sup> For higher flow capacity inlet filters, please consult factory.
- <sup>2</sup> Drain port must be downward for liquid removal.
- <sup>3</sup> Filter cartridge is permanently sealed into housing. The entire unit is disposable.



Parker Hannifin (UK) Ltd

Hermitage Court, Hermitage Lane, Maidstone, Kent ME16 9NT, England

Phone: +44 (0)1622 723 300 Fax: +44 (0)1622 728 703 E-mail: pagservicesupport@parker.com Web site: www.parker.com/pag



# Vacuum Pump Exhaust Filters for Non-Hazardous/Non-Corrosive Applications

## Benefits

**Eliminate 99.99% oil mist and smoke from vacuum pump exhaust**

**Prevent oil accumulation in pipework**

**Recover expensive lubricating oils, and automatically return filtered oil to pump**

**Eliminate potential health and safety hazards**

## Balston Vacuum Pump Exhaust Filters

Balston Vacuum Pump Exhaust Filters remove all visible oil mist and smoke from vacuum pump exhaust, even when it is saturated with oil. The high efficiency filter cartridge continuously drains the collected liquid, allowing the user to recover expensive lubricating fluid. Filters are available for pumps with flow ratings upto 1,444 m<sup>3</sup>/hr (850 CFM).

## How To Select The Filter

For most applications, simply select the filter assembly which has a flow capacity equal to or greater than the vacuum pump exhaust flow output (see chart below). The filter assemblies are shipped with filter cartridges, pressure gauge (34 m<sup>3</sup>/hr and larger), and final filter pad. Optional adaptors are available for KF and NW connections (see Pg 21).



## Filter Selection Chart (for non-hazardous/non-corrosive applications)

Max. Pump Flow Rate (m <sup>3</sup> /hr)	Recommended Filter Model Number
5	9955-12-371H, 9956-12-371H
15	18/18-371H
34	AR-0316-371H
73	AR-0335-371H
170	AR-0735-371H
340	AR-0780-371H
510	AR-1280-371H
765	AR-1680-371H
1,444	AR-3080-371H

# Vacuum Pump Exhaust Filters for Non-Hazardous/Non-Corrosive Applications

## Principal Specifications

	9955-12-371H	9956-12-371H	18/18-371H	AR-0316-371H	AR-0335-371H
<b>Port Size</b>	1/2" NPT	KF-16	3/4" NPT	1" NPT	1 1/2" NPT
<b>Max. Flow Rate</b>	5 m <sup>3</sup> /hr (3 CFM)	5 m <sup>3</sup> /hr (3 CFM)	15 m <sup>3</sup> /hr (9 CFM)	34 m <sup>3</sup> /hr (43 CFM)	73 m <sup>3</sup> /hr (43 CFM)
<b>Materials of Construction:</b>					
<b>Head</b>				Steel	Steel
<b>Bowl</b>	Nylon	Nylon	Steel	Steel	Steel
<b>Seals</b>	None	None	Viton	Buna/Neo	Buna/Neo
<b>Max. Temp.</b>	121°C (250°F)	121°C (250°F)	204°C (400°F)	204°C (400°F)	204°C (400°F)
<b>Max. Press.</b>	1 bar(g)	1 bar(g)	1 bar(g)	1 bar(g)	1 bar(g)
<b>Shipping Wt.</b>	0.1 kg	0.1 kg	0.4 kg	4 kg	5 kg
<b>Dimensions</b>	50 x 94 mm	50 x 94 mm	89 x 137 mm	191 x 229 mm	191 x 381 mm
	AR-0735-371H	AR-0780-371H	AR-1280-371H	AR-1680-371H	AR-3080-371H
<b>Port Size</b>	3" NPT	3" NPT	4" Flg. <sup>(1)</sup>	4" Flg. <sup>(1)</sup>	6" Flg. <sup>(1)</sup>
<b>Max. Flow Rate</b>	170 m <sup>3</sup> /hr (100 CFM)	340 m <sup>3</sup> /hr (200 CFM)	510 m <sup>3</sup> /hr (300 CFM)	765 m <sup>3</sup> /hr (450 CFM)	1,444 m <sup>3</sup> /hr (850 CFM)
<b>Materials of Construction:</b>					
<b>Head</b>	Steel	Steel	Steel	Steel	Steel
<b>Bowl</b>	Steel	Steel	Steel	Steel	Steel
<b>Seals</b>	Buna/Neo	Buna/Neo	Buna/Neo	Buna/Neo	Buna/Neo
<b>Max. Temp.</b>	204°C (400°F)	204°C (400°F)	204°C (400°F)	204°C (400°F)	204°C (400°F)
<b>Max. Press.</b>	1 bar(g)	1 bar(g)	1 bar(g)	1 bar(g)	1 bar(g)
<b>Shipping Wt.</b>	8 kg	10 kg	41 kg	45 kg	68kg
<b>Dimensions</b>	254 x 457 mm	254 x 711 mm	483 x 1,092 mm <sup>(5)</sup>	483 x 1,092 mm <sup>(5)</sup>	584 x 1,092 mm <sup>(5)</sup>

## Ordering Information

Model	No. of Filter Cartridges Required	Replacement Filter Cartridges			Cover <sup>(2)</sup> (Optional)	No. Pressure Relief Retainers #20222
		Box of 3	Box of 7	Box of 10		
9955-12-371H <sup>(3)</sup>		3/9955-12-371H		9955-12-371H		<sup>(4)</sup>
9956-12-371H <sup>(3)</sup>		3/9956-12-371H		9956-12-371H		<sup>(4)</sup>
18/18-371H <sup>(3)</sup>						<sup>(4)</sup>
AR-0316-371H	3	3/200-16-371H			19158	1
AR-0335-371H	3	3/200-35-371H			19158	1
AR-0735-371H	7		7/200-35-371H		19206	2
AR-0780-371H	7		7/200-80-371H		19206	2
AR-1280-371H	12			200-80-371H	Included	4
AR-1680-371H	16			200-80-371H	Included	4
AR-3080-371H	30			200-80-371H	Included	6

## Optional Accessories

#20222 Pressure Relief Filter Cartridge Retainer, 4-7 psig.  
 #20222 Pressure Relief Filter Cartridge Retainer, 2-5 psi.  
 #20217 Pressure Relief Valve, 3-7 psig, 1/4" NPT male fitting.  
 #11010 Pressure Gauge, 0-15 psig, 1/4" male fitting (incl. on Type AR Filter Assemblies)

### Vacuum pump-to-filter adaptors

#19291 Stand for AR-1680-371H, #19290 Stand for AR-3080-371H.  
 #19202 Weather Cap for AR-0735-371H, AR-0780-371H.

### Notes:

- 1 ANSI 150 lb. hole pattern.
- 2 Cover does not provide leak tight seal.
- 3 Filter cartridge is permanently sealed into housing. The entire unit is disposable.
- 4 Pressure relief filter tube retainer not available in these models.
- 5 Height dimension represents filter housing alone. When assembled with a stand, the height is adjustable from 1,170 to 1,420 mm.



Parker Hannifin (UK) Ltd

Hermitage Court, Hermitage Lane, Maidstone, Kent ME16 9NT, England

Phone: +44 (0)1622 723 300 Fax: +44 (0)1622 728 703 E-mail: pagservicesupport@parker.com Web site: www.parker.com/pag

# Vacuum Pump Exhaust Filters for Hazardous/Corrosive Applications

## Benefits

**Eliminate 99.9% oil mist and smoke from vacuum pump exhaust**

**Prevent oil accumulation in pipework**

**Recover expensive lubricating oils, and automatically return filtered oil to pump**

**Eliminate potential OSHA and EPA violations**

## Parker Vacuum Pump Exhaust Filters

Parker Vacuum Pump Exhaust Filters remove all visible oil mist and smoke from vacuum pump exhaust, even when it is saturated with oil. The high efficiency filter cartridge continuously drains the collected liquid, allowing the user to recover expensive lubricating fluid. Filters are available for pumps with flow ratings ranging from 5 to 340 m<sup>3</sup>/hr (200 CFM).

## How To Select The Filter

For most applications, simply select the filter assembly which has a flow capacity equal to or greater than the vacuum pump exhaust flow output (see chart below). The filter assemblies are shipped with filter cartridges, pressure gauge (34 m<sup>3</sup>/hr and larger), and final filter pad. Optional adaptors are available for KF and NW connections (see page 21).

## Principal Specifications

Model	CV-0112-371H	CV-0118-371H	ACV-0135-371H	ACV-0735-371H	ACV-0780-371H
<b>Port Size</b>	1/2" NPT	3/4" NPT	1" NPT	2" NPT	2" NPT
<b>Max. Flow Rate</b>	5 m <sup>3</sup> /hr (3 CFM)	15 m <sup>3</sup> /hr (9 CFM)	34 m <sup>3</sup> /hr (20 CFM)	170 m <sup>3</sup> /hr (100 CFM)	340 m <sup>3</sup> /hr (200 CFM)
<b>Materials of Construction</b>					
<b>Head</b>			304 SS	304 SS	304 SS
<b>Bowl</b>	304 SS	304 SS	304 SS	304 SS	304 SS
<b>Internals</b>	304 SS	304 SS	304 SS	304 SS	304 SS
<b>Seals</b>	None	None	Viton	Viton	Viton
<b>Maximum Temperature</b>	121°C (250°F)	121°C (250°F)	121°C (250°F)	121°C (250°F)	121°C (250°F)
<b>Maximum Pressure</b>	1 bar(g)	1 bar(g)	1 bar(g)	1 bar(g)	1 bar(g)
<b>Shipping Weight</b>	0.2 kg	0.4 kg	4.3 kg	25 kg	32 kg
<b>Dimensions</b>	70 x 110 mm	100 x 130 mm	100 x 580 mm	250 x 740 mm	250 x 960 mm

## Ordering Information

Model	CV-0112-371H <sup>(1)</sup>	CV-0118-371H <sup>(1)</sup>	ACV-0135-371H	ACV-0735-371H	ACV-0780-371H
<b>Number of Filter Cartridges Required</b>			1	7	7
<b>Replacement Filter Cartridges:</b>					
<b>Box of 3</b>			3/200-35-371H		
<b>Box of 7</b>				7/200-35-371H	
<b>Box of 10</b>			200-35-371H		
<b>Number of Pressure Relief Retainers #20222</b>			1	2	2
<b>Optional Accessories:</b>	#11015 Back Pressure Gauge, Stainless Steel, 0-15 psi rating, 1/4" NPT fitting.				
<b>Vacuum Pump-to-Filter Adaptors:</b>	Please refer to Page 21.				

### Notes:

<sup>1</sup> Filter cartridge is permanently sealed into housing. The entire unit is disposable. Pressure relief filter tube retainer not available in these models.



MODEL CV-0118

## Filter Selection Chart (for hazardous/corrosive applications)

Max. Pump Rate (m <sup>3</sup> /hr)	Recommended Flow Filter Model Number
<b>5</b>	CV-0112-371H
<b>15</b>	CV-0118-371H
<b>34</b>	ACV-0135-371H
<b>170</b>	ACV-0735-371H
<b>340</b>	ACV-0780-371H



# Recommended Exhaust Filters for Vacuum Pumps

Pump Model No.	Pump Rating (Free Air) m <sup>3</sup> /hr	Recommended Pump Exhaust (NPT Female Unless Otherwise Noted)	Parker Filter Non-Hazardous Non-Corrosive Applications	Recommended Balston Anodized Aluminium Pump -To- Filter Adaptor <sup>(1)</sup>	Balston Balston Filter Hazardous and Corrosive Applications	Stainless Steel Pump -To- Filter Adaptor <sup>(1)</sup>
<b>Alcatel Pumps</b>						
ZM/ZT 1004A/AC	5	NW 25	18/18	14175	CV-0112	14182
ZM/ZT 1012A	19	NW 25	AR-0316	14173	ACV-0135	14177
ZM/ZT 1030	29	1" OD Tube	AR-0316		ACV-0135	
ZM/ZT 1033	46	NW 40	AR-0335	14174		
ZT 1060	51	1.63" OD Tube	AR-0335			
ZT 1063	85	NW 40	AR-0735	14174 <sup>(2)</sup>	ACV-0735	14178 <sup>(3)</sup>
ZT 1200A	255	1.63" OD Tube	AR-0780		ACV-0780	
ZM/ZT 2004A	5	NW 25	18/18	14173	CV-0112	14182
ZM/ZT 2007	12	NW 25	18/18	14173	CV-0118	14182
ZM/ZT 2008A/AC	12	NW 25	18/18	14173	CV-0118	14182
ZM/ZT 2012A/AC/H	19	NW 25	AR-0316	14173	ACV-0135	14177
UM/UT 2020	27	NW 25	AR-0316	14173	ACV-0135	14177
ZM/ZT 2030/H	29	1" OD Tube	AR-0316		ACV-0135	
ZM/ZT 2033/C	46	NW 40	AR-0335	14174		
ZT 2060/H/HUS	51	1.63" OD Tube	AR-0335			
ZT 2063/C	85	NW 40	AR-0735	14174 <sup>(2)</sup>	ACV-0735	14178 <sup>(3)</sup>
ZT 2100A/AC	153	NW 50	AR-0735		ACV-0735	14179 <sup>(3)</sup>
2002A	1.4	DN16	9955-12, 9956-12	-	CV-0112	-
2005	3.8	DN25	18/18	-	CV-0118	-
2015	10.6	DN25	AR-0316	-	ACV-1035	-
2021	14.6	DN25	AR-0316	-	ACV-1035	-
2010	6.8	DN16	9955-12, 9956-12	-	CV-0118	-
AMD1	0.82	DN16	9955-12, 9956-12	-	CV-0112	-
AMD4	2.36	DN16	9955-12, 9956-12	-	CV-0112	-
A100L	55.8	DN25	AR-0735	-	ACV-0735	-
<b>Roots Vacuum Pumps</b>						
RSV 151	89	ISO/DN63	AR-0735	-	ACV-0735	-
RSV 301	177	ISO/DN63	AR-0780	-	ACV-0780	-
RSV 601	354	ISO/DN100	AR-1680	-	ACV-0780 <sup>(multiple)</sup>	-
RSV 1002	594	ISO/DN100	-	-	ACV-0780 <sup>(multiple)</sup>	-
RSV	1200	ISO/DN160	-	-	ACV-0780 <sup>(multiple)</sup>	-
<b>LRS1</b>						
RSV 151B+RVP2033D	106	DN40	AR-0780	-	ACV-0780	-
RSV 301B+2033D	212	DN40	AR1280	-	ACV-0780 <sup>(multiple)</sup>	-
RSV 301B+RVP 2063D	212	DN40	AR1280	-	ACV-0780 <sup>(multiple)</sup>	-
<b>LRS2</b>						
RSV 151+RVP 2021	106	DN25	AR-0780	-	ACV-0780	-
RSV 601+RVP 2033	424	DN40	AR1680	-	ACV-0780 <sup>(multiple)</sup>	-
<b>MRS1</b>						
RSV 301B+AMV 200/300	212	DN50	AR1280	-	ACV-0780 <sup>(multiple)</sup>	-
RSV 601B+AMV 200/300	212	DN40	AR1280	-	ACV-0780 <sup>(multiple)</sup>	-
RSV 1002AMV 200/300	424	DN40	AR1280	-	ACV-0780 <sup>(multiple)</sup>	-
<b>Balzars Pumps</b>						
UNO/DUO 1.5A	2	KF10	9955-12		CV-0112	
UNO/DUO 004A/B	5	KF25	9955-12	14175	CV-0112	14182
UNO/DUO 008A/B	9	KF25	18/18	14173	CV-0118	14182
UNO/DUO 012A	14	KF25	18/18	14173	CV-0118	14182
UNO/DUO 016B	18	KF25	AR-0316	14173	ACV-0135	14177
UNO/DUO 030A	34	KF40	AR-0316	14174	ACV-0135	14178 <sup>(5)</sup>
UNO/DUO 060A	67	KF40	AR-0335	14174		
UNO/DUO 250A	267	ISO 100	AR-0780		ACV-0780	

**Notes:**

- 1 If no part number is listed, adaptor is not supplied by Parker. In most cases, customer can assemble adaptor from standard pipe fittings. Refer to page 19.
- 2 Requires 3" Male x 1 1/2" Female reducing bushing supplied by customer.
- 3 Requires 2" Male x 1 1/2" Female reducing bushing supplied by customer.
- 4 Exhaust port is horizontal. Customer should provide elbow so that filter is mounted vertically.
- 5 Requires 1" Male x 1 1/2" Female bushing supplied by customer.
- 6 Multiple filters piped in parallel are required.



**Parker Hannifin (UK) Ltd**

Hermitage Court, Hermitage Lane, Maidstone, Kent ME16 9NT, England

Phone: +44 (0)1622 723 300 Fax: +44 (0)1622 728 703 E-mail: [pagsservicesupport@parker.com](mailto:pagsservicesupport@parker.com) Web site: [www.parker.com/pag](http://www.parker.com/pag)

# Recommended Exhaust Filters for Vacuum Pumps

Pump Model No.	Pump Rating (Free Air) m <sup>3</sup> /hr	Recommended Pump Exhaust (NPT Female Unless Otherwise Noted)	Parker Filter Non-Hazardous Non-Corrosive Applications	Recommended Balston Anodized Aluminium Pump -To- Filter Adaptor <sup>(1)</sup>	Balston Balston Filter Hazardous and Corrosive Applications	Stainless Steel Pump -To- Filter Adaptor <sup>(1)</sup>
UNO 100	95	32mm OD Tube <sup>(4)</sup>	AR-0735		ACV-0735	
DUO 100	97	32mm OD Tube <sup>(4)</sup>	AR-0735		ACV-0735	
UNO/DUO 120A	127	ISO 63	AR-0735		ACV-0735	
UNO 170	155	32mm OD Tube <sup>(4)</sup>	AR-0735		ACV-0735	
DUO 170	170	32mm OD Tube <sup>(4)</sup>	AR-0735		ACV-0735	
BA 251	270	ISO 63	AR-0780		ACV-0780	
BA 501	545	ISO 100	AR-1680		ACV-0780 <sup>(4)</sup>	
UNO 2.5	1.7	DN16	9955-12, 9956-12	-	CV-0112	-
UNO 6	3.5	G 3/8	18/18	-	CV-0118	-
UNO 20	12.4	ISO-KF25	AR-0335	-	ACV-1035	-
UNO 60	36.5	-	AR-0735	-	ACV-0735-371H	-
UNO 90	55.3	DN40	AR-0735	-	ACV-0735	-
UNO 200	123.6	DN	AR-1280	-	ACV-0780	-
UNO 240	158.9	DN	AR-1280	-	ACV-0780	-
UNO 400	270.7	DN63 ISO-F	AR-3080	-	ACV-0780 <sup>(multiple)</sup>	-
UNO 630	400.2	DN63 ISO-F	AR-3080	-	ACV-0780 <sup>(multiple)</sup>	-
DUO 5	3.5	DN16	18/18	-	CV-0118	-
DUO 10	7	DN25	AR-0316	-	CV-0118	-
DUO 20	14.1	DN25	AR-0335	-	ACV-1035	-
DUO 35	21.2	DN40	AR-0335	-	ACV-0735	-
DUO 65	41.2	DN100	AR-0735	-	ACV-0735	-
DUO 120	84.7	DN63	AR-0780	-	ACV-0735	-
DUO 250	176.6	DN100	AR1280	-	ACV-0780	-
<b>Beach-Russ Pumps</b>						
SS 1	10	3/4"	18/18		CV-0118	
SS 1	15	3/4"	18/18		CV-0118	
SS 2	25	3/4"	AR-0316		ACV-0135	
SS 3	48	1"	AR-0335			
SS 4	77	1 1/4"	AR-0735		ACV-0735	
SS 5	102	1 1/2"	AR-0735		ACV-0735	
RP/RV 6	14	1/2"	18/18		CV-0118	
SS 6	127	1 1/2"	AR-0735		ACV-0735	
SS 7	187	2"	AR-0780		ACV-0780	
SS 8	255	2 1/2"	AR-0780		ACV-0780	
SS 9	382	4"	AR-1280		ACV-0780 <sup>(2)</sup>	
SS 10	637	6"	AR-1680		ACV-0780 <sup>(2)</sup>	
RP/RV 12	31	3/4"	AR-0316		ACV-0135	
RP 15	51	1 1/2"	AR-0335			
RP 15-6	51	1"	AR-0335			
RP 30	85	1 1/2"	AR-0735		ACV-0735	
RP 30-6	85	1"	AR-0735		ACV-0735	
RP 50/50-6	136	2"	AR-0735		ACV-0735	
RP 135/135-12	238	3"	AR-0780		ACV-0780	
RP-150/150-12	297	3"	AR-0780		ACV-0780	
RP 250	527	5"	AR-1280		ACV-0780 <sup>(2)</sup>	
RP 250-12	527	4"	AR-1280		ACV-0780 <sup>(2)</sup>	
RP 325	637	5"	AR-1680		ACV-0780 <sup>(2)</sup>	
RP 325-12	637	4"	AR-1680		ACV-0780 <sup>(2)</sup>	
RP 375	850	6"	AR-3080		ACV-0780 <sup>(2)</sup>	
RP 375-50	850	4"	AR-3080		ACV-0780 <sup>(2)</sup>	
RP 750	1,529	8"	AR-1680 <sup>(2)</sup>		ACV-0780 <sup>(2)</sup>	
RP 750-50	1,529	5"	AR-1680 <sup>(2)</sup>		ACV-0780 <sup>(2)</sup>	
RP 1000	1,869	8"	AR-3080 <sup>(2)</sup>		ACV-0780 <sup>(2)</sup>	
RP 1000-50	1,896	5"	AR-3080 <sup>(2)</sup>		ACV-0780 <sup>(2)</sup>	
84-A-RVF	250	-	AR1280		ACV-0780 <sup>(multiple)</sup>	
98-A-RVF	410	-	AR1680		ACV-0780 <sup>(multiple)</sup>	

**Notes:**

1 If no part number is listed, adaptor is not supplied by Parker. In most cases, customer can assemble adaptor from standard pipe fittings. Refer to pages 18.

2 Multiple filters piped in parallel are required.

3 Requires flange to NPT adaptor from pump manufacturer.

4 Requires 3/4" Male x 1/2" Female reducing bushing supplied by customer.

# Recommended Exhaust Filters for Vacuum Pumps

Pump Model No.	Pump Rating (Free Air) m <sup>3</sup> /hr	Recommended Pump Exhaust (NPT Female Unless Otherwise Noted)	Parker Filter Non-Hazardous Non-Corrosive Applications	Recommended Balston Anodized Aluminium Pump -To- Filter Adaptor <sup>(1)</sup>	Balston Balston Filter Hazardous and Corrosive Applications	Stainless Steel Pump -To- Filter Adaptor <sup>(1)</sup>
14	8.5	4"	18/18		CV-0118	
20	12	4"	AR-0316		ACV-1035	
25	17	4"	AR-0316		ACV-1035	
42	25	4"	AR-0335		ACV-0735	
60	38	4"	AR-0335		ACV-0735	
128	75	4"	AR-0735		ACV-0735	
170	103	4"	AR-0780		ACV-0735	
240	141	4"	AR-0780		ACV-0780	
320	189	4"	AR-0780		ACV-0780	
480	285	4"	AR-1280		ACV-0780 <sup>(multiple)</sup>	
642	378	4"	AR-1680		ACV-0780 <sup>(multiple)</sup>	
910	540	4"	AR-3080		ACV-0780 <sup>(multiple)</sup>	
1210	710	4"	AR-3080		ACV-0780 <sup>(multiple)</sup>	
OTL/VP30	50	1.5"	AR-0735		ACV-0735	
OTL/VP50	80	2"	AR-0735		ACV-0735	
OTL/VP135	140	3"	AR-0780		ACV-0780	
OTL/VP150	175	3"	AR-0780		ACV-0780	
OTL/VP250	310	5"	AR-1680		ACV-0780 <sup>(multiple)</sup>	
OTL/VP325	375	5"	AR-1680		ACV-0780 <sup>(multiple)</sup>	
3P	48	1.5"	AR-0735		ACV-0735	
4P	73	1.5"	AR-0735		ACV-0735	
5P	100	2.5"	AR-0780		ACV-0735	
6P	125	2.5"	AR-0780		ACV-0780	
7P	175	3"	AR-0780		ACV-0780	
8P	225	3"	AR-1280		ACV-0780 <sup>(multiple)</sup>	
9P	300	4"	AR-1280		ACV-0780 <sup>(multiple)</sup>	
0	1	1/4"	9955-12, 9956-12		CV-0112	
1	2	1/4"	9955-12, 9956-12		CV-0112	
<b>Busch Pumps</b>						
002-192	2	KF-16	9956-12		CV-0112	14181
004-192	5	KF-16	9956-12		CV-0112	14181
008-192	10	KF-16	18/18	14172	CV-0118	14181 <sup>(4)</sup>
010-112/118	10	3/4"	18/18		CV-0118	
016-192	19	KF-16	AR-0316	14180	ACV-0135	14176
016-112/118	14	3/4" <sup>(3)</sup>	18/18		CV-0118	
021-336/338	25	3/4" <sup>(3)</sup>	AR-0316		ACV-0135	
025-132/138	34	1 1/4" <sup>(3)</sup>	AR-0316		ACV-0135	
040-132/138	48	1 1/4" <sup>(3)</sup>	AR-0335			
063-132/138	70	1 1/4" <sup>(3)</sup>	AR-0335			
110-132/138	107	1 1/4" <sup>(3)</sup>	AR-0735		ACV-0735	
160-112/118/132/138	199	2" <sup>(3)</sup>	AR-0780		ACV-0780	
216-002	212	2"	AR-0780		ACV-0780	
225-002	340	2"	AR-0780		ACV-0780	
240-002	510	2"	AR-1280		ACV-0780 <sup>(2)</sup>	
250-112/118/132/138	296	2" <sup>(3)</sup>	AR-0780		ACV-0780	
263-002	850	2"	AR-3080		ACV-0780 <sup>(2)</sup>	
400-212/218	510	2"	AR-1280		ACV-0780 <sup>(2)</sup>	
630-212/218	731	3" <sup>(3)</sup>	AR-1680		ACV-0780 <sup>(2)</sup>	
1000-212/228	1,104	6" <sup>(3)</sup>	AR-3080		ACV-0780 <sup>(2)</sup>	
1600-212/228	1869	6" <sup>(3)</sup>	AR-3080 <sup>(2)</sup>		ACV-0780 <sup>(2)</sup>	
429	212	2"	AR-0780		ACV-0780	
433	340	2"	AR-0780		ACV-0780	
437	527	2"	AR-1280		ACV-0780 <sup>(2)</sup>	
441	985	2"	AR-3080		ACV-0780 <sup>(2)</sup>	
445	1,325	6" <sup>(3)</sup>	AR-3080		ACV-0780 <sup>(2)</sup>	
0004	3.3	3/8"	18/18		CV-0118	
0006	4.2	3/8"	18/18		CV-0118	
0012	7.1	3/4"	18/18		CV-0118	
0016	11.2	3/4"	AR-0316		ACV-1035	
0100	63	3/4"	AR-0735		ACV-0735	

# Recommended Exhaust Filters for Vacuum Pumps

Pump Model No.	Pump Rating (Free Air) m <sup>3</sup> /hr	Recommended Pump Exhaust (NPT Female Unless Otherwise Noted)	Parker Filter Non-Hazardous Non-Corrosive Applications	Recommended Balston Anodized Aluminium Pump -To- Filter Adaptor <sup>(1)</sup>	Balston Balston Filter Hazardous and Corrosive Applications	Stainless Steel Pump -To- Filter Adaptor <sup>(1)</sup>
0255	180	2"	AR-0780		ACV-0780	
0305	212	2"	AR-1280		ACV-0780 <sup>(multiple)</sup>	
0400	330	3"	AR-1680		ACV-0780 <sup>(multiple)</sup>	
0502	413	3"	AR-1680		ACV-0780 <sup>(multiple)</sup>	
0630	490	3"	AR-3080		ACV-0780 <sup>(multiple)</sup>	
1000	704	6" [USA]	AR-3080		ACV-0780 <sup>(multiple)</sup>	
1600	1130	6" [USA]	AR-3080 <sup>(2)</sup>		ACV-0780 <sup>(multiple)</sup>	
HO 0429	113	2"	AR-0780		ACV-0780	
HO 0433	176	2"	AR-0780		ACV-0780	
HO 0437	282	3"	AR-1280		ACV-0780 <sup>(multiple)</sup>	
HO 0441	444	3"	AR-16780		ACV-0780 <sup>(multiple)</sup>	
LC 0030	20.6	G1	AR-0335		ACV-0735	
LC 0060	38.3	G1	AR-0335		ACV-0735	
LC 0080	54.1	DIN40	AR-0735		ACV-0735	
LC 0110	74.7	DIN40	AR-0735		ACV-0735	
LC 0150	100	DIN40	AR-0735		ACV-0735	
LC 0220	153	DIN50	AR-0780		ACV-0780	
LC 0280	200	DIN65	AR-0780		ACV-0780	
LC 0400	271	DIN65	AR-1280		ACV-0780 <sup>(multiple)</sup>	
<b>Central Scientific Pumps (Cenco, Boekel, HYVAC)</b>						
HYVAC 1 (91105)	0.6	3/8"	9955-12		CV-0112	
HYVAC 2 (91305/8)	1.5	1/2"	9955-12		CV-0112	
HYVAC 4 (91482)	3	1/2"	9955-12		CV-0112	
HYVAC 7(91506, 91502)	5	1/2"	9955-12		CV-0112	
HYVAC 7S (91138)	5	1/2"	9955-12		CV-0112	
HYVAC 14 (91705)	10	3/4"	18/18		CV-0118	
HYVAC 14S (91140)	10	3/4"	18/18		CV-0118	
HYVAC 28 (91905)	19	1 1/2"	AR-0316		ACV-0135	
HYVAC 28S (91142)	19	1 1/2"	AR-0316		ACV-0135	
HYVAC 45 (91955)	31	1 1/2"	AR-0316		ACV-0135	
HYVAC 150 (91957)	90	3"	AR-0735		ACV-0735	
HYVAC 300 (91960)	180	3"	AR-0780		ACV-0780	
MEGAVAC (92003)	3	1/2"	9955-12		CV-0112	
PRESSOVAC (90510/15/16)	2	3.8" OD Tube	9955-12		CV-0112	
DIRECT DRIVE (90703)	4	3/8"	9955-12		CV-0112	
DIRECT DRIVE (90700)	2	3/8"	9955-12		CV-0112	
2120	4.4	KF25	18/18		CV-0118	
2200	7.3	KF25	18/18		CV-0118	
HYPERVAC400	13.4	NW25	AR-0316		ACV-1035	
HYPERVAC600	21	NW25	AR-0335		ACV-0735	
HYPERVAC1000	32	NW40	AR-0335		ACV-0735	
HYPERVAC1500	53	NW40	AR-0735		ACV-0735	
HYPERVAC30L	1.1		9955-12, 9956-12		CV-0112	
HYPERVAC50L	2		9955-12, 9956-12		CV-0112	
PRESSOVAC (90510)	1.2	5/8"	9955-12, 9956-12		CV-0112	
MEGAVAC92001	2	1/2"	9955-12, 9956-12		CV-0112	
MEGAVAC1500	50	PORTS ADAPTABLE	AR-0735		ACV-0735	
MEGAVAC2500	88	PORTS ADAPTABLE	AR-0735		ACV-0735	
MEGAVAC4500	150	PORTS ADAPTABLE	AR-0780		ACV-0780	
MEGAVAC7500	250	PORTS ADAPTABLE	AR-1280		ACV-0780 <sup>(multiple)</sup>	
MEGAVAC15000	300	PORTS ADAPTABLE	AR-1280		ACV-0780 <sup>(multiple)</sup>	

**Notes:**

- 1 If no part number is listed, adaptor is not supplied by Parker. In most cases, customer can assemble adaptor from standard pipe fittings. Refer to pages 21.
- 2 Exhaust port is horizontal. Customer should provide elbow so that filter is mounted vertically.
- 3 Multiple filters piped in parallel are required.
- 4 Reducing bushing required. Customer to provide.

# Recommended Exhaust Filters for Vacuum Pumps

Pump Model No.	Pump Rating (Free Air) m <sup>3</sup> /hr	Recommended Pump Exhaust (NPT Female Unless Otherwise Noted)	Parker Filter Non-Hazardous Non-Corrosive Applications	Recommended Balston Anodized Aluminium Pump -To- Filter Adaptor <sup>(1)</sup>	Balston Balston Filter Hazardous and Corrosive Applications	Stainless Steel Pump -To- Filter Adaptor <sup>(1)</sup>
SUPRVAC012	7.5	1/2" FNPT	18/18		CV-0118	
SUPRVAC021	15	1/2" FNPT	AR-0316		ACV-1035	
SUPRVAC025	20	1"	AR-0335		ACV-1035	
SUPRVAC040	30	1"	AR-0735		ACV-0735	
SUPRVAC063	45	1"	AR-0735		ACV-0735	
SUPRVAC0100	70	1"	AR-0735		ACV-0735	
SUPRVAC0160	110	2"	AR-0780		ACV-0780	
SUPRVAC0250	150	2"	AR-0780		ACV-0780	
0505	9.5	1"	AR-0316		ACV-1035	
1505	19	1"	AR-0316		ACV-1035	
2010	27	1"	AR-0335		ACV-0735	
7530	59	2"	AR-0735		ACV-0735	
10030	84	2"	AR-0735		ACV-0735	
<b>Edwards High Vacuum Pumps</b>						
SPEEDIVAC 2	3	3/8 BSPT	9955-12	14157	CV-0112	
E2M1	2	3/8 BSPT	9955-12	14157	CV-0112	
E2M2	3	3/4 BSPT	9955-12	14158	CV-0112	
E1/E2M5	6	3/4 BSPT	18/18	14159	CV-0118	
EDM6	8	1/2"	18/18		CV-0118	
E1/E2M8	12	3/4 BSPT	18/18	14159	CV-0118	
EDM12	17	1/2"	AR-0316		ACV-0135	
E1/E2M18	26	3/4"	AR-0316		ACV-0135	
EDM20	26	1/2"	AR-0316		ACV-0135	
E2M30	52	KF25	AR-0335	14183		
E1/E2M40	52	KF25	AR-0335	14183		
ED/ES 50	7	1/4"	18/18		CV-0118	
ED/ES65	3	1/4" <sup>(2)</sup>	9955-12		CV-0112	
E1/E2M80	97	KF25	AR-0735	14183 <sup>(2)</sup>	ACV-0735	14177 <sup>(2)</sup>
ED/ES100	6	1/4" <sup>(2)</sup>	18/18		CV-0118	
E1/E2M175	212	1 1/2"	AR-0780		ACV-0780	
ED/ES200	12	3/8" <sup>(2)</sup>	18/18		CV-0118	
E1/E2M275	246	1 1/2"	AR-0780		ACV-0780	
ES330	20	3/8" <sup>(2)</sup>	AR-0316		ACV-0135	
ISC 450	34	1/2"	AR-0316		ACV-0135	
ED 500	31	1/2"	AR-0316		ACV-0135	
ED660	39	1/2" <sup>(2)</sup>	AR-0335			
ISC 900	66	3/4"	AR-0335			
ES2000	121	1 1/2"	AR-0735		ACV-0735	
ES4000	246	1 1/2"	AR-0780		ACV-0780	
ES7500	467	2 1/2"	AR-1280		ACV-0780 <sup>(2)</sup>	
RV3	5	3/4"	9955-12	<sup>(2)</sup>	CV-0112	<sup>(2)</sup>
RV5	7	NW25	18/18	14173	CV-0118	14182
RV8	12	NW25	18/18	14173	CV-0118	14182
RV12	17	NW25	AR-0316	14173	ACV-0135	14177
<b>Gast Pumps</b>						
0211	2	1/4"	9955-12		CV-0112	
0240	3	1/4"	9955-12		CV-0112	
0322	5	1/4"	9955-12		CV-0112	
0440	6	1/4"	18/18		CV-0118	
0465	6	3/8"	18/18		CV-0118	
0522	6	1/4"	18/18		CV-0118	
0740	10	3/8"	18/18		CV-0118	
0765	10	3/8"	18/18		CV-0118	

**Notes:**

- 1 If no part number is listed, adaptor is not supplied by Parker. In most cases, customer can assemble adaptor from standard pipe fittings. Refer to pages 21.
- 2 Exhaust port is horizontal. Customer should provide elbow so that filter is mounted vertically.
- 3 Multiple filters piped in parallel are required.



**Parker Hannifin (UK) Ltd**

Hermitage Court, Hermitage Lane, Maidstone, Kent ME16 9NT, England

Phone: +44 (0)1622 723 300 Fax: +44 (0)1622 728 703 E-mail: pagservicesupport@parker.com Web site: www.parker.com/pag

# Recommended Exhaust Filters for Vacuum Pumps

Pump Model No.	Pump Rating (Free Air) m <sup>3</sup> /hr	Recommended Pump Exhaust (NPT Female Unless Otherwise Noted)	Parker Filter Non-Hazardous Non-Corrosive Applications	Recommended Balston Anodized Aluminium Pump -To- Filter Adaptor <sup>(1)</sup>	Balston Balston Filter Hazardous and Corrosive Applications	Stainless Steel Pump -To- Filter Adaptor <sup>(1)</sup>
0822	12	3/8"	18/18		CV-0118	
1022	17	3/8"	AR-0316		ACV-0135	
1065	14	1/2"	18/18		CV-0118	
1550	20	1/2"	AR-0316		ACV-0135	
2065	29	3/4"	AR-0316		ACV-0135	
2067	29	3/4"	AR-0316		ACV-0135	
2565	36	3/4"	AR-0335		ACV-0135	
3040	53	1"	AR-0335			
4565	82	3/4"	AR-0735		ACV-0735	
5565	93	1"	AR-0735		ACV-0735	
4BA-1-G482X	3	1/2"	9955-12		CV-0112	
4AB-1-G482X	3	1/2"	9955-12		CV-0112	
4BA-1-G492X	3	1/2"	9955-12		CV-0112	
4BA-1-G499	3	1/2"	9955-12		CV-0112	
4BA-1-G511X	3	1/2"	9955-12		CV-0112	
4BA-1-G538X	3	1/2"	9955-12		CV-0112	
5BA-1-G482X	6	1/2"	18/18		CV-0118	
5AB-1-G482X	6	1/2"	18/18		CV-0118	
5BB-1-G482X	6	1/2"	18/18		CV-0118	
6BA-1-G535X	12	1"	18/18		ACV-0135	
6AB-1-G504X	12	1"	18/18		ACV-0135	
7BA-1-G506X	19	1"	R-0316		ACV-0135	
7AB-1-G506X	19	1"	R-0316		ACV-0135	
8BA-1-G506X	24	1 1/4"	R-0316		ACV-0135	
8AB-G506X	24	1 1/4"	R-0316		ACV-0135	
1531	1.5	1/8"	9955-12, 9956-12		CV-0112	
0532	0.6	1/8"	9955-12, 9956-12		CV-0112	
1032	1.1	1/4"	9955-12, 9956-12		CV-0112	
1532	1.5	1/4"	9955-12, 9956-12		CV-0112	
2032	2.5	1/4"	9955-12, 9956-12		CV-0112	
3032	2.6	1/4"	9955-12, 9956-12		CV-0112	
0211	1.3	1/4"	9955-12, 9956-12		CV-0112	
2070	20	1"	AR-0335		ACV-0735	
0323-1423	13	3/4"	AR-0316			
0533	1.6	1/4"	9955-12, 9956-12		CV-0112	
1033	1.1	1/4"	9955-12, 9956-12		CV-0112	
1034	1.6	1/4"	9955-12, 9956-12		CV-0112	
1534	2.2	1/4"	9955-12, 9956-12		CV-0112	
2040-0740	6	3/8"	18/18		CV-0118	
0456	4	3/8"	18/18		CV-0118	
0765	6	3/8"	18/18		CV-0118	
1550	14.5	1/2"	AR-0316		ACV-1035	
1065-2565	8.5-21	3/4"	AR-0335		ACV-0735	
2067-2567	17-21	3/4"	AR-0335		ACV-0735	
3040	40	3/4"	AR-0335		ACV-0735	
4565	47.5	1"	AR-0735		ACV-0735	
5565	55	1"	AR-0735		ACV-0735	
6066	55	1"	AR-0735		ACV-0735	
1290	112	1"	AR-0780		ACV-0780	
<b>Hitachi Pumps</b>						
SVF 10F	6	M24 x 1	18/18	14168	CV-0118	
SVR 16F	10	M24 x 1	18/18	14168	CV-0118	
100 VPS	6	M24 x 1	18/18	14168	CV-0118	
160 VPD/VPS	10	M24 x 1	18/18	14168	CV-0118	
16 VP	10	M24 x 1	18/18	14168	CV-0118	
3 VPC	3	M14 x 1	9955-12		CV-0112	
4 VPC	6	M14 x 1	18/18		CV-0118	



# Recommended Exhaust Filters for Vacuum Pumps

Pump Model No.	Pump Rating (Free Air) m <sup>3</sup> /hr	Recommended Pump Exhaust (NPT Female Unless Otherwise Noted)	Parker Filter Non-Hazardous Non-Corrosive Applications	Recommended Balston Anodized Aluminium Pump -To- Filter Adaptor <sup>(1)</sup>	Balston Balston Filter Hazardous and Corrosive Applications	Stainless Steel Pump -To- Filter Adaptor <sup>(1)</sup>
<b>Ingersoll-Rand Pumps</b>						
AV/AVX2	5	3/8"	9955-12		CV-0112	
BV/BVX2	8	3/8"	18/18		CV-0118	
V23A/V23AX7	15	3/4"	18/18		CV-0118	
V235/V235X1	31	1"	AR-0316		ACV-0135	
V244/V244X2	54	1 1/4"	AR-0335			
V255/V255X3	102	1 1/2"	AR-0735		ACV-0735	
V255X5	102	1 1/2"	AR-0735		ACV-0735	
7V/7VX5	168	1 1/2"	AR-0735		ACV-0735	
15V/15VX7	226	2"	AR-0780		ACV-0780	
20VX10	364	2 1/2"	AR-1280		ACV-0780 <sup>(2)</sup>	
20V/20VX15	500	2 1/2"	AR-1280		ACV-0780 <sup>(2)</sup>	
15VD7.5	132	2"	AR-0780		ACV-0780	
20VX15	214	2.5"	AR-1280		ACV-0780 <sup>(multiple)</sup>	
2V/235D1.5	36		AR-0335		ACV-0735	
2-V244D2	36		AR-0335		ACV-0735	
2-V255031D5	120		AR-0780		ACV-0780	
2-7E7.5	198		AR-0780		ACV-0780	
2-15VE7.5	264		AR-1280		ACV-0780 <sup>(multiple)</sup>	
2-20VA15	428		AR-1680		ACV-0780 <sup>(multiple)</sup>	
2-20VA20	588		AR-3080		ACV-0780 <sup>(multiple)</sup>	
255	60	1.5"	AR-0735		ACV-0735	
<b>ITT Pneumotive (Leiman Brothers)</b>						
B	17	3/4"	AR-0316		ACV-0135	
C	31	1"	AR-0316		ACV-0135	
29-3J	34	1"	AR-0316		ACV-0135	
195-2	34	3/4"	AR-0316		ACV-0135	
C-3	37	1"	AR-0335			
30-3	59	1"	AR-0335			
C-6	63	1 1/2"	AR-0335			
29-6J	85	1 1/2"	AR-0735		ACV-0735	
30-6	102	1 1/2"	AR-0735		ACV-0735	
100	190	1 1/2"	AR-0780		ACV-0780	
100J	212	1 1/2"	AR-0780		ACV-0780	
107/107J	340	3"	AR-0780		ACV-0780	
<b>Kinney Pumps</b>						
KC/KVS/KVC-2	3	3/4"	9955-12		CV-0112	
KC/KVC-3	5	3/4"	9955-12		CV-0112	
KC-5	8	3/4"	18/18		CV-0118	
KVC-6	10	3/4"	18/18		CV-0118	
KC-8	14	3/4"	AR-0316		ACV-0135	
KS-13	22	1 1/4"	AR-0316		ACV-0135	
TCS-14	24	3/4"	AR-0316		ACV-0135	
KC-15	25	1 1/4"	AR-0316		ACV-0135	
KS-15	25	1 1/4"	AR-0316		ACV-0135	
KTC-21	36	1"	AR-0335			
TCS-21	36	3/4"	AR-0335			
KD-30	56	1 1/4"	AR-0335			
TCS-35	51	1 1/4"	AR-0335	14174		
KD-50	88	1 1/4"	AR-0735		ACV-0735	
TCS-55	92	1 1/2"	AR-0735		ACV-0735	
KTC-60	102	1 1/2" <sup>(2)</sup>	AR-0735		ACV-0735	
KDH-65	117	1 1/2"	AR-0735		ACV-0735	
TCS-70	121	1 1/2"	AR-0735		ACV-0735	
KDH-80	141	1 1/2"	AR-0735		ACV-0735	
TCS-90	150	2"	AR-0735		ACV-0735	
KTC-112	182	2" <sup>(2)</sup>	AR-0780		ACV-0780	
KDH-130	228	2"	AR-0780		ACV-0780	

## Notes:

1 If no part number is listed, adaptor is not supplied by Parker. In most cases, customer can assemble adaptor from standard pipe fittings. Refer to pages 21.

2 Multiple filters piped in parallel are required



**Parker Hannifin (UK) Ltd**

Hermitage Court, Hermitage Lane, Maidstone, Kent ME16 9NT, England

Phone: +44 (0)1622 723 300 Fax: +44 (0)1622 728 703 E-mail: [pagservicesupport@parker.com](mailto:pagservicesupport@parker.com) Web site: [www.parker.com/pag](http://www.parker.com/pag)

# Recommended Exhaust Filters for Vacuum Pumps

Pump Model No.	Pump Rating (Free Air) m <sup>3</sup> /hr	Recommended Pump Exhaust (NPT Female Unless Otherwise Noted)	Parker Filter Non-Hazardous Non-Corrosive Applications	Recommended Balston Anodized Aluminium Pump -To- Filter Adaptor <sup>(1)</sup>	Balston Balston Filter Hazardous and Corrosive Applications	Stainless Steel Pump -To- Filter Adaptor <sup>(1)</sup>
KDH-150	280	2"	AR-0780		ACV-0780	
KT-150	244	2" <sup>(2)</sup>	AR-0780		ACV-0780	
KTC-225	375	3" <sup>(2)</sup>	AR-1280		ACV-0780 <sup>(3)</sup>	
KT-300	503	3" <sup>(2)</sup>	AR-1280		ACV-0780 <sup>(3)</sup>	
KT-500	839	3" <sup>(2)</sup>	AR-3080		ACV-0780 <sup>(3)</sup>	
KT-850	1,321	4" Flange	AR-3080		ACV-0780 <sup>(3)</sup>	
KT-170LP	100	2"	AR-0735		ACV-0780	
KT-275LP	162	2"	AR-0780		ACV-0780	
KT-505LP	300	3"	AR-1680		ACV-0780 <sup>(multiple)</sup>	
KT-840LP	490	4"	AR-3080		ACV-0780 <sup>(multiple)</sup>	
KT-135VFP	780	5"	AR-3080		ACV-0780 <sup>(multiple)</sup>	
<b>Lammert Pumps</b>						
10301	3	1/2"	9955-12		CV-0112	
10302	3	1/2"	9955-12		CV-0112	
10305/01131	8	3/4"	18/18		CV-0118	
10307/01133	14	1"	18/18		CV-0118	
10310/02131	17	1"	AR-0316		ACV-0135	
02133	25	3/4"	AR-0316		ACV-0135	
03131/03231	34	1 1/4"	AR-0316		ACV-0135	
04231/04131	51	1 1/4"	AR-0335			
03133/03233	51	1 1/4"	AR-0335			
04133/04233	85	1 1/4"	AR-0735		ACV-0735	
05131/05231	127	2"	AR-0735		ACV-0735	
06231/05133/05233	170	2"	AR-0735		ACV-0735	
07231	212	3"	AR-0780		ACV-0780	
06233/08231	255	3"	AR-0780		ACV-0780	
07233	340	3"	AR-0780		ACV-0780	
08233/09231	425	3"	AR-1280		ACV-0780 <sup>(3)</sup>	
09233	595	3"	AR-1680		ACV-0780 <sup>(3)</sup>	
<b>Leybold Heraeus Pumps</b>						
D/S 2A	3	KF 16	9956-12		CV-0112	14181
D/S 4A	8	KF 16	18/18	14172	CV-0118	14181 <sup>(3)</sup>
D/S 8A	12	KF 25	18/18	14173	CV-0118	14182
D 4B	5	KF 16	18/18	14172	CV-0118	14181 <sup>(3)</sup>
D 8B	12	KF 16	18/18	14172	CV-0118	14181 <sup>(3)</sup>
D/S 16A	24	KF 25	AR-0316	14173	ACV-0135	14177
D25	34	KF 25	AR-0316	14173	ACV-0135	14177
D/S 30A	46	KF 40	AR-0335	14178		
SV 40	51	1 1/4"	AR-0335			
DK 50	54	KF 50	AR-0335			
D/S 60A	63	KF 40	AR-0335	14178		
D 65	90	KF 40	AR-0735	14174 <sup>(4)</sup>	ACV-0735	14178 <sup>(2)</sup>
SV 65	76	1 1/4"	AR-0335		ACV-0335	
E 75	83	KF 50	AR-0735		ACV-0735	14179 <sup>(2)</sup>
D/S 90A	93	KF 40	AR-0735	14174 <sup>(4)</sup>	ACV-0735	14178 <sup>(2)</sup>
DK 100	110	KF 50	AR-0735		ACV-0735	14179 <sup>(2)</sup>
SV 100	119	2"	AR-0735		ACV-0735	
E 150	160	KF 50	AR-0735		ACV-0735	14179 <sup>(2)</sup>
SV 180	212	2"	AR-0780		ACV-0780	
DK 200	130	3" ASA Flange	AR-0780		ACV-0780	
E 250	162	3" ASA Flange	AR-0780		ACV-0780	
SV 280	340	2"	AR-0780		ACV-0780	
SV 500	318	3"	AR-1280		ACV-0780 <sup>(5)</sup>	
SV 580	339	3"	AR-1680		ACV-0780 <sup>(5)</sup>	
D25BCS	20		AR-0316		ACV-0135	
D40BCS	32.5		AR-0335		ACV-0735	
D65BCS	53		AR-0735		ACV-0735	

## Notes:

- 1 If no part number is listed, adaptor is not supplied by Parker. In most cases, customer can assemble adaptor from standard pipe fittings. Refer to page 21.
- 2 Requires 2" Male x 1 1/2" Female reducing bushing supplied by customer.
- 3 Requires 3/4" Male x 1/2" Female reducing bushing supplied by customer.
- 4 Requires 3" Male x 1 1/2" Female reducing bushing supplied by customer.
- 5 Requires Multiple Filters piped in parallel.

# Recommended Exhaust Filters for Vacuum Pumps

Pump Model No.	Pump Rating (Free Air) m <sup>3</sup> /hr	Recommended Pump Exhaust (NPT Female Unless Otherwise Noted)	Parker Filter Non-Hazardous Non-Corrosive Applications	Recommended Balston Anodized Aluminium Pump -To- Filter Adaptor <sup>(1)</sup>	Balston Filter Hazardous and Corrosive Applications	Stainless Steel Pump -To- Filter Adaptor <sup>(1)</sup>
D25B	20.9		AR-0335		ACV-0735	
SV16B	11.2		AR-0316		ACV-0135	
SV25B	18.3	1/2" NPT	AR-0136		ACV-0135	
SV65B	41.8		AR-0335		ACV-0735	
SV100B	68.9		AR-0735		ACV-0735	
SV200	129.5		AR-0780		ACV-0780	
SV300	200	2" BSP	AR-0780		ACV-0780	
SV500	336		AR-1680		ACV-0780(multiple filters)	
SV630	494.8		AR-3080		ACV-0780(multiple filters)	
SV1200	677		AR-3080		ACV-0780(multiple filters)	
SP250	177		AR-0780		ACV-0780(multiple filters)	
SP630	371		AR-1680		ACV-0780	
SV40B	31.2		AR-1335		ACV-0780(multiple filters)	
D10E	9.3		AR-0316	ACV-0135		
<b>Marvac Pumps</b>						
A-1	2	3/8"	9955-12		CV-0112	
A-2	2	3/8"	9955-12		CV-0112	
A-10	3	3/8"	9955-12		CV-0112	
A-20	3	3/8"	9955-12		CV-0112	
A-222	7	1/2"	18/18		CV-0118	
B-2	5	1/2"	9955-12		CV-0112	
B-3	10	3/4"	18/18		CV-0118	
B-6	34	1 1/4"	AR-0316		ACV-0135	
B-20	7	1/2"	18/18		CV-0118	
B-30	15	1"	18/18		CV-0118	
B-222	12	3/4"	18/18		CV-0118	
R-10	3	3/8"	9955-12		CV-0112	
R-20	3	3/8"	9955-12		CV-0112	
R-22	5	3/8"	9955-12		CV-0112	
R-55	10	3/8"	18/18		CV-0118	
<b>Maxima Pumps (Thermo Fisher)</b>						
D2A (01-057-2A)	3	KF 16	9956-12		CV-0112	14181
D4A (01-057-4A)	9	KF 16	18/18	14172	CV-0118	14181 <sup>(3)</sup>
D8A (01-057-8A)	12	KF 25	18/18	14173	CV-0118	14182
D16A (01-057-16A)	24	KF 25	AR-0316	14173	ACV-0135	14177
D30A (01-057-30A)	46	KF 40	AR-0335	14174		
D60A (01-057-60A)	63	KF 40	AR-0335	14174 <sup>(4)</sup>		
D90A (01-057-90A)	93	KF 40	AR-0735		ACV-0735	14178 <sup>(2)</sup>
M4C	2.6		9955-12, 9956-12		CV-0112	
M6C	3.4		18/18-371H		CV-0118	
M8C	6.1		18/18-371H		CV-0118	
<b>Precision Scientific Pumps</b>						
DD-20	2	3/4"	9955-12		CV-0112	
D-25	2	3/4"	9955-12		CV-0112	
S/PV-35	2	3/4"	9955-12		CV-0112	
DD-50	3	3/4"	9955-12		CV-0112	
D-75	5	3/4"	9955-12		CV-0112	
DD-90	5	3/4"	18/18		CV-0118	
DD-100	6	3/4"	18/18		CV-0118	
D-150	8	3/4"	18/18		CV-0118	
DD/DDC-195	12	3/4"	18/18		CV-0118	
S/D-300	19	1"	AR-0316		ACV-0135	
DD/DDC 310	19	3/4"	AR-0316		ACV-0135	
DD/DDC 475	29	3/4"	AR-0316		ACV-0135	
S/D-500	31	1 1/4"	AR-0316		ACV-0135	
S/D-1000	59	1 1/2"	AR-0335			
S/D-1500	90	1 1/2"	AR-0735		ACV-0735	

## Notes:

1 If no part number is listed, adaptor is not supplied by Parker. In most cases, customer can assemble adaptor from standard pipe fittings. Refer to page 21.

2 Multiple filters piped in parallel are required.

3 Requires 1 1/2" Male x 1" Female reducing bushing supplied by customer.

4 Requires 3" Male x 1 1/2" Female reducing bushing supplied by customer.

5 Requires 2" Male x 1 1/2" Female reducing bushing supplied by customer.



**Parker Hannifin (UK) Ltd**

Hermitage Court, Hermitage Lane, Maidstone, Kent ME16 9NT, England

Phone: +44 (0)1622 723 300 Fax: +44 (0)1622 728 703 E-mail: [pagsservicesupport@parker.com](mailto:pagsservicesupport@parker.com) Web site: [www.parker.com/pag](http://www.parker.com/pag)

# Recommended Exhaust Filters for Vacuum Pumps

Pump Model No.	Pump Rating (Free Air) m <sup>3</sup> /hr	Recommended Pump Exhaust (NPT Female Unless Otherwise Noted)	Parker Filter Non-Hazardous Non-Corrosive Applications	Recommended Balston Anodized Aluminium Pump -To- Filter Adaptor <sup>(1)</sup>	Balston Balston Filter Hazardous and Corrosive Applications	Stainless Steel Pump -To- Filter Adaptor <sup>(1)</sup>
<b>Quincy Pumps</b>						
QSVB-10	134	1 1/4"	AR-0735		ACV-0735	
QSVB-20	227	1 1/4"	AR-0780		ACV-0780	
QSVI-20	270	2 1/2"	AR-0780		ACV-0780	
QSVI-40	535	2 1/2"	AR-1280		ACV-0780 <sup>(2)</sup>	
QV-.75	8.5	.5" NPT	18/18		CV-0118	
QV-1	12	.5" NPT	AR-0316		ACV-0135	
QV-1.5	25	.75" NPT	AR-0335			
QV-2	38	1" NPT	AR-0335			
QV-3	50	1" NPT	AR-0735			
QV-5	75	1.5" NPT	AR-0735			
QV-5.5	103	1.5" NPT	AR-0780			
QV-7.5	141	2" NPT	AR-0780			
QV-10	189	2" NPT	AR-0780			
QV-15	245	3" NPT	AR-1280			
QV-20	378	3" NPT	AR-1680			
QV-30	540	4" NPT	AR-3080			
QV-40	716	4" NPT	AR-3080			
<b>Rietschle Pumps</b>						
VAL/VL/VE 10	12	NW 25	18/18	14173	CV-0118	14182
VF/VFE/CLFG 11	12	1/2"	18/18		CV-0118	
VF/VFE 16	17	1/2"	AR-0316		ACV-0135	
CLFG/CLF/CLFE 16	17	1/2"	AR-0316		ACV-0135	
VAL/VL/MLV 25	29	NW 25	AR-0316	14173	ACV-0135	14177
VF/VFE 26	29	3/4"	AR-0316		ACV-0135	
CLFG/CLF/CLFE 26	29	3/4"	AR-0316		ACV-0135	
VL/MLV 40	51	NW 25	AR-0335	14183		
VF/VFE 41	46	3/4"	AR-0335			
CLFG/CLF/CLFE 41	46	3/4"	AR-0335			
VL/MLV 60	68	3/4"	AR-0335			
VF/VFE 61	68	3/4"	AR-0335			
CLFG/CLF/CLFE 61	68	3/4"	AR-0335			
VL/MLV 80	92	NW 40	AR-0735	14174 <sup>(4)</sup>	ACV-0735	14178 <sup>(5)</sup>
VF/VFE 81	92	1	AR-0735		ACV-0735	
CLFG/CLF/CLFE 81	92	1	AR-0735		ACV-0735	
VL/MLV 100	114	NW 40	AR-0735	14174 <sup>(4)</sup>	ACV-0735	14178 <sup>(5)</sup>
VF/VFE 101	114	1 1/4"	AR-0735		ACV-0735	
CLFG/CLF/CLFE 101	114	1 1/4"	AR-0735		ACV-0735	
VWZ 102	114	NW 65	AR-0735		ACV-0735	
CLF/CLFE 141	160	1 1/2"	AR-0735		ACV-0735	
VFH/VFEH 161	183	2	AR-0780		ACV-0780	
VWZ 162	183	NW 65	AR-0780		ACV-0780	
CLF/CLFE 181	183	2"	AR-0780		ACV-0780	
VWZ 252	287	NW 65	AR-0780		ACV-0780	
CLFH/CLFEH 341	391	3"	AR-1280		ACV-0780*	
VWZ 402	459	NW 65	AR-1280		ACV-0780*	
CLFH/CLFEH 501	574	3"	AR-1680		ACV-0780*	
CLFH/CLFEH 631	724	3"	AR-1680		ACV-0780*	
CLFH/CLFEH 1001	1,150	3"	AR-3080		ACV-0780*	
VLV25-2	18	3/4" NPT	AR-0316		ACV-0135	
VLV25-3	18		AR-0316		ACV-0135	
VLV40-2	28	3/4" NPT	AR-0335		ACV-0735	
VLV40-3	28		AR-0335		ACV-0735	
VWZ702	494		AR-3080		ACV-0780(multiple filters)	
VWZ1002	706		AR-3080		ACV-0780(multiple filters)	
VGD10	7		18/18-371H		CV-0118	
VGD15	11		AR-3016		ACV-0135	
VCE15	11	1/2" NPT	AR-3016		ACV-0135	
VCE25	18	3/4" NPT	AR-3016		ACV-0135	
VCE40	28	1" NPT	AR-0335		ACV-0735	
VC50	35	1-1/4" NPT	AR-0335		ACV-0735	
VCE60	42	1" NPT	AR-0335		ACV-0735	

## Notes:

1 If no part number is listed, adaptor is not supplied by Parker. In most cases, customer can assemble adaptor from standard pipe fittings. Refer to page 21.

2 Multiple filters piped in parallel are required.

3 Requires 3" Male x 1 1/2" Female reducing bushing supplied by customer.

4 Requires 2" Male x 1 1/2" Female reducing bushing supplied by customer.

# Recommended Exhaust Filters for Vacuum Pumps

Pump Model No.	Pump Rating (Free Air) m <sup>3</sup> /hr	Recommended Pump Exhaust (NPT Female Unless Otherwise Noted)	Parker Filter Non-Hazardous Non-Corrosive Applications	Recommended Balston Anodized Aluminium Pump -To- Filter Adaptor <sup>(1)</sup>	Balston Balston Filter Hazardous and Corrosive Applications	Stainless Steel Pump -To- Filter Adaptor <sup>(1)</sup>
VC75	49	1-1/4" NPT	AR-0735		ACV-0735	
VC100	71	1-1/2" NPT	AR-0735		ACV-0735	
VC150	105	1-1/2" NPT	AR-0780		ACV-0780	
VC200	141	2" NPT	AR-0780		ACV-0780	
VC300	212	2" NPT	AR-1280		ACV-0780(multiple filters)	
VC400	282	3" NPT	AR-1280		ACV-0780(multiple filters)	
VC500	388	3" NPT	AR-1680		ACV-0780(multiple filters)	
VC700	494	3" NPT	AR-3080		ACV-0780(multiple filters)	
VC900	636	4" NPT	AR-3080		ACV-0780(multiple filters)	
VC1100	777	4" NPT	AR-3080		ACV-0780(multiple filters)	
VC1300	918	4" NPT			ACV-0780(multiple filters)	
VLR100	72	1-1/2" NPT	AR-0735		ACV-0735	
VLR250	166	2" NPT	AR-0780		ACV-0780	
VL5300	212	2" NPT	AR-1280		ACV-0780(multiple filters)	
VLR400	272	3" NPT	AR-1280		ACV-0780(multiple filters)	
VLR500	353	3" NPT	AR-1680		ACV-0780(multiple filters)	
<b>RO-FLO Pumps (Allis-Chalmers)</b>						
5CCA	93	1 1/2"	AR-0735		ACV-0735	
5CCB	146	1 1/2"	AR-0735		ACV-0735	
7DB	257	3"	AR-0780		ACV-0780	
7DC	399	3"	AR-1280		ACV-0780 <sup>(2)</sup>	
8DB	467	3"	AR-1280		ACV-0780 <sup>(2)</sup>	
8DE	586	3"	AR-1680		ACV-0780 <sup>(2)</sup>	
10GB	698	4"	AR-1680		ACV-0780 <sup>(2)</sup>	
10GC	1,008	4"	AR-3080		ACV-0780 <sup>(2)</sup>	
11S	1,254	5"	AR-3080			
11L	1,424	5"	AR-3080			
12S	1,648	6"	AR-3080 <sup>(2)</sup>			
12L	1,835	6"	AR-3080 <sup>(2)</sup>			
17S	2,086	6"	AR-3080 <sup>(2)</sup>			
17L	2,413	6"	AR-3080 <sup>(2)</sup>			
19S	2,876	8"	AR-3080 <sup>(2)</sup>			
19L	3,262	8"	AR-3080 <sup>(2)</sup>			
23C	3,857	8"	AR-3080 <sup>(2)</sup>			
23D	4,655	8"	AR-3080 <sup>(2)</sup>			
27D	5,607	10"	AR-3080 <sup>(2)</sup>			
33D	10,109	14"	AR-3080 <sup>(2)</sup>			
<b>Sargent-Welch Pumps</b>						
1373	19	1-20	AR-0316	14163	ACV-0135	
1374	39	1-3/4-20	AR-0335	14164		
1375	59	Square Flange	AR-0335			
1376	19	1-20	AR-0316 <sup>(3)</sup>	14163	ACV-0135 <sup>(3)</sup>	
1380	10	1-20	18/18	14162	CV-0118	
1392	2	3/4-20	9955-12	14165	CV-0112	
1395	121	Square Flange	AR-0735		ACV-0735	
1396	170	Square Flange	AR-0735		ACV-0735	
1397	31	1-3/4-20	AR-0316	14160	ACV-0135	
1398	90	Square Flange	AR-0735		ACV-0735	
1399	2	3/4-20	9955-12	14165	CV-0112	
1400	2	3/4-20	9955-12	14165	CV-0112	
1402	10	1-20	18/18	14162	CV-0118	
1403	7	1-20	18/18	14162	CV-0118	
1405	3	3/4-20	9955-12	14165	CV-0112	
1410	2	1/2" Hose	9955-12		CV-0112	
8802	2	3/4-20	9955-12	14165	CV-0112	
8803B/8804B	2	3/4-20	9955-12	14165	CV-0112	
8803K/8804K	2	3/4-20	9955-12	14165	CV-0112	
8805	3	1-20	9955-12	14166	CV-0112	
8806B/K	3	NW 25	9955-12	14175	CV-0112	14182
8810	7	1-20	9955-12	14166	CV-0118	
8811B	7	NW 25	18/18	14173	CV-0118	14182
8811K	5	NW 25	9955-12	14175	CV-0112	14182
8814	10	NW 25	18/18	14173	CV-0112	14182
8815	8	1-20	18/18	14162	CV-0118	

**Notes:**

- 1 If no part number is listed, adaptor is not supplied by Parker. In most cases, customer can assemble adaptor from standard pipe fittings. Refer to page 21.
- 2 Multiple filters piped in parallel are required.
- 3 Consult factory for piping considerations.
- 4 Requires 3/4" male x 1/2" female reducing bushing supplied by customer.



**Parker Hannifin (UK) Ltd**

Hermitage Court, Hermitage Lane, Maidstone, Kent ME16 9NT, England

Phone: +44 (0)1622 723 300 Fax: +44 (0)1622 728 703 E-mail: pagservicesupport@parker.com Web site: www.parker.com/pag

# Recommended Exhaust Filters for Vacuum Pumps

Pump Model No.	Pump Rating (Free Air) m <sup>3</sup> /hr	Recommended Pump Exhaust (NPT Female Unless Otherwise Noted)	Parker Filter Non-Hazardous Non-Corrosive Applications	Recommended Balston Anodized Aluminium Pump -To- Filter Adaptor <sup>(1)</sup>	Balston Balston Filter Hazardous and Corrosive Applications	Stainless Steel Pump -To- Filter Adaptor <sup>(1)</sup>
8816B/K	8	NW 25	18/18	14173	CV-0118	14182
8821	12	NW 25	18/18	14173	CV-0118	14182
8830	17	1-3/4-20	AR-0316	14160	ACV-0135	
8834	20	NW 40	AR-0316	14174	ACV-0135	14184
8851	31	NW 40	AR-0316	14174	ACV-0135	14184
8861	59	NW 50	AR-0335	14179		
8871	90	NW 50	AR-0735	14179	ACV-0735	
8890	14	3/4-20	18/18	14173	CV-0118	14182
8905	3	NW 16	9956-12		CV-0112	14181
8910	7	NW 16	18/18	14172	CV-0118	14181 <sup>(4)</sup>
8910A	5	NW 16	18/18	14172	CV-0118	14181 <sup>(4)</sup>
8915	10	1-20	18/18	14162	CV-0118	
8920	14	NW 25	18/18	14173	CV-0118	14182
<b>Stokes Pumps</b>						
V-005	12	NW 25	18/18	14173	CV-0118	14182
V-009	19	NW 25	AR-0316	14173	ACV-0135	14177
V-013-2	34	NW 40	AR-0316	14174		
V-017-2	63	NW 40	AR-0335	14174		
V-23	93	NW 40	AR-0735	14174 <sup>(3)</sup>	ACV-0735	14178 <sup>(4)</sup>
146H	51	1 1/4"	AR-0335		ACV-0335	
148H	85	1 1/2"	AR-0735		ACV-0735	
149H	136	1 1/2"	AR-0735		ACV-0735	
149HS	170	1 1/2"	AR-0735		ACV-0735	
212HS	255	2"	AR-0780		ACV-0780	
412H	510	3"	AR-1280		ACV-0780 <sup>(2)</sup>	
612H	1,020	3"	AR-3080		ACV-0780 <sup>(2)</sup>	
<b>Ulvac Pumps</b>						
G-5	0.3	M17 x 1	9955-12		CV-0112	
G-15	1.0	3/4"	9955-12		CV-0112	
G/GC-25S	1.3	3/4"	9955-12		CV-0112	
G/GC-20D	1.3	3/4"	9955-12		CV-0112	
G-50S/D	3	3/4"	9955-12		CV-0112	
GC-50D	3	3/4"	9955-12		CV-0112	
G-100S/D	6	1"	18/18		CV-0118	
GC-100D	6	1"	18/18		CV-0118	
GVD-050	3	3/4"	9955-12		CV-0112	
GVD-100	9	1"	18/18		CV-0118	
GVD-165	12	3/4"	18/18		CV-0118	
DA-30S	2	3/4"	9955-12		CV-0112	
DA-60S	5	3/4"	9955-12		CV-0112	
D-330D	15	1 1/2"	18/18		CV-0118	
D-650D	31	1 1/2"	AR-0316		ACV-0135	
D-950D	46	2"	AR-0335			
PKS-016	97	2"	AR-0735		ACV-0735	
PKS-030	182	3"	AR-0780		ACV-0780	
PKS-070	425	4"	AR-1280		ACV-0780 <sup>(2)</sup>	
PVD-180	10	3/4"	18/18		CV-0118	
PDV-360	22	1"	AR-0316		ACV-0135	
<b>Varian Pumps</b>						
CS/SS/SD-90	5	NW 25	18/18	14173	CV-0118	14182
EVAC 200	12	3/4"	18/18		CV-0118	
EVAC 300	19	3/4"	AR-0316		ACV-0135	
CD/SD-200	12	NW 25	18/18	14173	CV-0118	14182
CD/SS/SD-300	19	NW 25	AR-0316	14173	ACV-0135	14177
CD/SS/SD-700	46	NW 40	AR-0335	14174		
CD/SS/SD-1400	85	NW 40	AR-0735	14173 <sup>(3)</sup>	ACV-0735	14178 <sup>(4)</sup>
CD/SD-2500	153	NW 50	AR-0735	14179 <sup>(3)</sup>	ACV-0735	

**Notes:**

- 1 If no part number is listed, adaptor is not supplied by Parker. In most cases, customer can assemble adaptor from standard pipe fittings. Refer to page 21.
- 2 Multiple filters piped in parallel are required.
- 3 Requires 3" Male x 1 1/2" Female reducing bushing supplied by customer.
- 4 Requires 2" Male x 1 1/2" Female reducing bushing supplied by customer



# Pump to Filter Adaptors

## Pump to Filter Adaptors - Straight Thread to NPT Thread

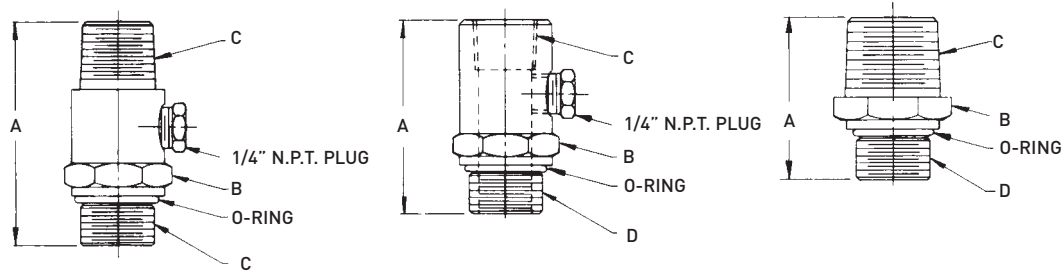

### Principal Specifications

Type	Adaptor Style	Materials of Construction			Dimensions (Inches)		
		Adaptor	Seals	(A) Height	(B) Hex Size	(C) NPT Thread	(D) Thread
14168	1	Alum.	Buna-N	3.0	1.25	3/4	M24 x 1
14166	2	Alum.	Buna-N	2.6	1.25	1/2 F <sup>(1)</sup>	1-20
14165	2	Alum.	Buna-N	2.44	1.25	1/2 F <sup>(1)</sup>	3/4-20
14164	3	Alum.	Buna-N	2.88	2.0	1 1/2	1 3/4-20
14163	3	Alum.	Buna-N	2.19	1.38	1	1-20
14162	1	Alum.	Buna-N	3.0	1.25	3/4	1-20
14160	3	Alum.	Buna-N	2.3	2.0	1	1 3/4-20
14159	1	Alum.	Buna-N	3.15	1.25	3/4	3/4 BSPT
14158	2	Alum.	Buna-N	2.80	1.25	1/2 F <sup>(1)</sup>	3/4 BSPT
14157	2	Alum.	Buna-N	2.56	1.25	1/2 F <sup>(1)</sup>	3/8 BSPT

**Notes:**

1 Female NPT - all others Male

## Pump to Filter Adaptors - Flange to NPT Thread

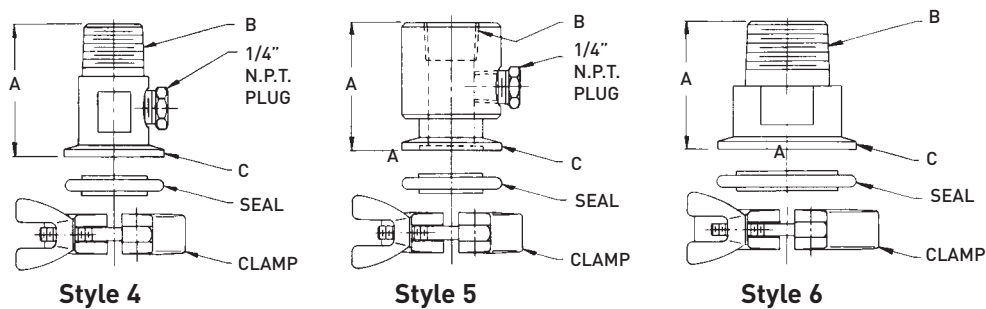

### Principal Specifications

Type	Adaptor Style	Materials of Construction			Dimensions (Inches)			Other Fittings Included
		Adaptor	Clamp	Seals	(A) Height	(B) NPT Thread	(C) KF Flange <sup>(2)</sup>	
14184	6	Stain. St.	Alum.	Viton	2.0	1	KF-40	3/4" x 1/2" Reducing Bushing
14183	6	Alum.			2.38	1 1/2	KF-25	
14182	4	Stain. St.			2.06	1/2	KF-25	
14181	4	Stain. St.			2.12	1/2	KF-16	
14180	6	Alum.			2.0	1	KF-16	1 1/2" x 1" Reducing Bushing 1" x 3/4" Reducing Bushing 1/2" coupling and 3/4" x 1/2" Reducing Bushing
14179	6	Stain. St.			2.62	1 1/2	KF-50	
14178	6	Stain. St.			2.38	1 1/2	KF-40	
14177	6	Stain. St.			2.0	1	KF-25	
14176	6	Stain. St.			2.0	1	KF-16	
14175	5	Alum.			2.0	1/2 F <sup>(1)</sup>	KF-25	
14174	6				2.0	1	KF-40	
14173	4				2.06	3/4	KF-25	
14172	4				2.12	1/2	KF-16	

**Notes:**

1 Female NPT - all others are Male

2 The designation "KF" and "NW" are interchangeable



Parker Hannifin (UK) Ltd

Hermitage Court, Hermitage Lane, Maidstone, Kent ME16 9NT, England

Phone: +44 (0)1622 723 300 Fax: +44 (0)1622 728 703 E-mail: pagservicesupport@parker.com Web site: www.parker.com/pag

# What is a vacuum pump and what are they used for?

## Applications:

**Industrial Vacuum Processes**

**Pharmaceutical**

**Medical**

**Food Processing**

**Meat Packaging**

**Factory**

**Automation**

**Pneumatic**

**Conveying**

**Chemical Processing**

**Print Production**

**Woodworking**



## High Quality, Low Maintenance

Vacuum pumps are used in a variety of applications from manufacturing processes to medical devices. In general, a vacuum pump provides high quality, reliable performance and is a low maintenance piece of equipment.

## How it Works

Vacuum pumps convert mechanical energy into pneumatic energy by evacuating the air contained within a system. They use the same pumping mechanism as air compressors except that the unit is installed so that the air is drawn from a closed volume and Exhausted to the atmosphere.

In a compressed air system the compressor inlet is usually at atmospheric pressure, whereas in a vacuum system, the outlet is at atmospheric pressure.

## Lubricated vs. Non-lubricated

Pumps are generally offered in an oil-less or oil-lubricated version. Oil-lubricated vacuum pumps have many advantages if they are properly maintained. They can usually provide 20% higher vacuum because the lubricant acts as a sealant. The life of an oil-lubricated vacuum pump is usually extended by 50% due to cooler operation and better protection against corrosion from condensed water vapor.

## All Pumps Require Filtration Protection

A vacuum pump, whether it is oil-less or not, requires Exhaust filtration protection. One requirement of vacuum pump maintenance is making sure that the operator provides and maintains a filter for the vacuum Exhaust. Regardless of the type of vacuum pump you have, using a Parker Exhaust filter will ensure a cleaner work environment.

# Why filter vacuum pump Exhaust?

## Put 99.9% clean air into YOUR work environment

A vacuum pump will Exhaust smoke and visible oil mist into the air. Installing a Parker Exhaust filter will eliminate 99.9% of the oil mist and smoke from vacuum pump Exhaust. This will prevent oil accumulation in the ambient air, which could otherwise cause health hazards for employees and potential violations from OSHA and the EPA.

## Eliminate oil in duct work

When oily air is emitted from a vacuum pump, the contaminants are circulated throughout the building through the duct work. This can create dirty intake air for other equipment such as air compressors, packaging machines, etc.

## Recover expensive lubricating oils

Oil prices have risen dramatically in the past few years. Your Parker vacuum pump Exhaust filter can recover expensive lubricating oils and return filtered oil back to the pump. This reduces overall maintenance costs.

# Global Company

## Local Support

---

Parker is the leader in motion and control, partnering with its customers to increase their productivity and profitability.

With an annual turnover of over \$10 billion and 57,000 employees Parker measures its success by what it does for you. Guided by a relentless drive to improve your products and processes, we bring our engineering know-how to your application, wherever it may be.

From 60 sales offices in 44 countries around the world Parker services 12,000 distributors and 427,000 customers.



### Quality Manufacturing

With over 270 manufacturing plants, Parker's manufacturing experience spans more than half a century. Our global reputation as a reliable supplier of superior products results from a focused and integrated development and manufacturing system. This begins with the customer – identifying needs, exploring opportunities and meeting the challenge of change.

Quality permeates through the entire corporation so that every employee thinks about our customers expectations.

Parker makes the technology investments needed to ensure the highest quality products. Each of our divisions has ISO certification.

### Premier Customer Service

We are doing more for our customers than ever before. Globally, we have localized service to provide fast, hassle free response and on-site support. We're staying close to our customers and integrating systems to help them become more profitable. We are committed to delivering our highly engineered products on-time, on-promise. Parker's global customer service centres respond to more than 20,000 enquiries each month, helping callers quickly find the products and solutions they need.



### Innovation

We are leveraging our engineering expertise and breadth of product to create breakthrough innovations, processes and services that anticipate, rather than react, to customer needs. We're adapting our technology platforms across the markets we serve, combining what we know in new ways to better serve our customers. And we're creating smarter products by blending our expertise in electronic controls with our mechanical devices.



**Parker Hannifin (UK) Ltd**

Hermitage Court, Hermitage Lane, Maidstone, Kent ME16 9NT, England

Phone: +44 (0)1622 723 300 Fax: +44 (0)1622 728 703 E-mail: [pagservicesupport@parker.com](mailto:pagservicesupport@parker.com) Web site: [www.parker.com/pag](http://www.parker.com/pag)

# Sales Offices Worldwide

## North America

### United States, Cleveland

phone 216 896 3000  
fax 216 896 4019

### United States, Haverhill

phone 978 858 0505  
fax 978 858 0625

### United States, Oxford

phone 248 628 6400  
fax 248 628 1850

## Asia Pacific

### China, Beijing

phone +86 10 6561 0520  
fax +86 10 6561 0526-7

### India, Mumbai

phone +91 22 6513 7081-85  
fax +91 22 2768 6841

### United Arab Emirates, Jebel Ali, Dubai

phone +971 2 6788587

## South America

### Argentina, Buenos Aires

phone +54 3327 44 4129  
fax +54 3327 44 4199

### Brazil, Jacarei

phone +55 12 3955 1000  
fax +55 12 3955 1010

## Europe

### Austria, Wiener Neustadt

phone +43 2622 235010  
fax +43 2622 66212

### Belgium, Nivelles

phone +32 67 280900  
fax +32 67 280 999

### Czech Republic, Klecany

phone +420 284 083 111  
fax +420 284 083 112

### Denmark, Ballerup

phone +45 43 560400  
fax +45 43 733107

### Finland, Vantaa

phone +358 (0)20 753 2500  
fax +358 (0)20 753 2501

## France, Contamine-sur-Arve

phone +33 04 5097 8714  
fax +33 04 5097 9510

## Germany, Kaarst

phone +49 2131 4016 0  
fax +49 2131 4016 9199

## Hungary, Budapest

phone +36 1 2204155  
fax +36 1 4221525

## Italy, Corsico

phone +39 02 451921  
fax +39 02 4479340

## Netherlands, Oldenzaal

phone +31 541 585000  
fax +31 541 585459

## Norway, Berghagan

phone +47 64 91 10 00  
fax +47 6491 10 90

## Poland, Warsaw

phone +48 22 57 32 400  
fax +48 22 57 32 403

## Spain, Madrid

phone +34 902 33 00 01  
fax +34 91 6757711

## Sweden, Spånga

phone +46 8 5979 5000  
fax +46 8 5979 5120

## Switzerland, Geneva

phone +41 22 307 7111  
fax +41 22 307 7110

## Turkey, Istanbul

phone +90 212 4829106  
fax +90 212 4829110

June 2008 / S3.2.244



Parker Hannifin (UK) Ltd  
**Filtration and Separation**  
Hermitage Court  
Hermitage Lane  
Maidstone, Kent ME16 9NT  
phone +44 (0)1622 723300  
fax +44 (0)1622 728703  
[www.parker.com/pag](http://www.parker.com/pag)

Your Local Authorized Parker Distributor