

B Series Ball Valve

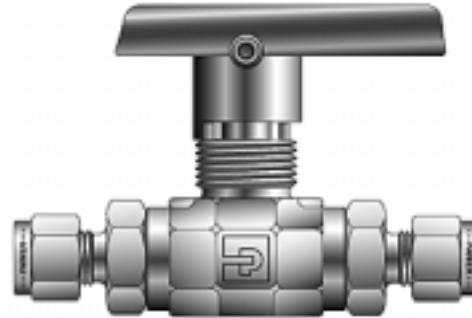

Maximum Allowable Working Pressure and Temperature

| Seat Material | Valve Body Material | |
|---------------|--|--|
| | Brass or Alloy 400 | Stainless Steel |
| PTFE | 1500 psig @ 70 °F 10.40 MPa @ 21 °C | 1500 psig at 70 °F 10.40 MPa at 21 °C |
| PCTFE | 3000 psig @ 70 °F 20.70 MPa @ 21 °C | 6000 psig @ 70 °F 41.40 MPa @ 21 °C |

The arrow on the Valve Handle may be used to indicate the normal direction of flow.

The 3-Way B Series Ball Valves are designed exclusively for directional flow control. The 3-Way B Series Ball Valves are NOT recommend for shutoff service. Always consult your authorized Parker representative if questions arise.

INSTALLATION OF PANEL MOUNTED VALVES

| Ball Valve Size | Panel Thickness (max) | Through-Hole Diameter |
|-----------------|-----------------------|-----------------------|
| B2 | 1/8 inch (3.2 mm) | 37/64 inch (14.7 mm) |
| B6 | 1/4 inch (6.4 mm) | 49/64 inch (19.5 mm) |
| B8 | 3/8 inch (9.4 mm) | 57/64 inch (22.6 mm) |

When the Valve is mounted to a thin panel, a spacer (or washer) may be necessary to permit full Panel Nut engagement on the Valve.

- Remove the Handle by turning the Set Screw counter-clockwise with the following size hex-socket wrench:

| | |
|-----------|-----------|
| B2 valves | 5/64 inch |
| B6 valves | 3/32 inch |
| B8 valves | 1/8 inch |
- Insert the Valve through the panel hole and assemble the Panel Nut. Snug the Panel Nut finger-tight, followed by proper tightening.
- Adjust the Stem packing as explained below (except for Valves with an O-Ring Stem packing), and re-install the Handle.

PACKING ADJUSTMENT (For B-Series Ball Valves with PTFE Stem Packing)

Packing adjustment may be occasionally necessary depending on the many and varied uses for the Valve. It is recommended an adjustment be made shortly after initial installation and just prior to flow start-up. Always consult your authorized Parker representative if questions arise.

1. Remove the Handle by turning the Set Screw counter-clockwise with the following size hex-socket wrench:

| | |
|-----------|-----------|
| B2 valves | 5/64 inch |
| B6 valves | 3/32 inch |
| B8 valves | 1/8 inch |

2. Tighten the Packing Nut 1/8 to 1/4 turn or to the following torque using the specified hex wrench size.

| Ball Valve Size | Hex Wrench Size | Tightening Torque |
|-----------------|-----------------|---------------------|
| B2 | 5/16 inch | 30 In-lbs (3.3 N-m) |
| B6 | 7/16 inch | 70 In-lbs (7.8 N-m) |
| B8 | 1/2 inch | 90 In-lbs (10 N-m) |

3. Re-install the Handle and secure by turning the Set-Screw clockwise and torque to 15 In-lbs.

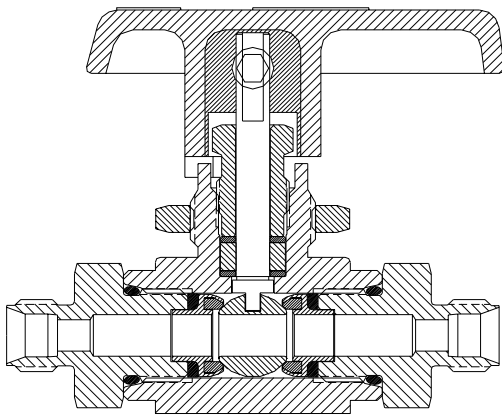

Figure 1: Two-Way B Series Ball Valve with PTFE Packing Cross Sectional View

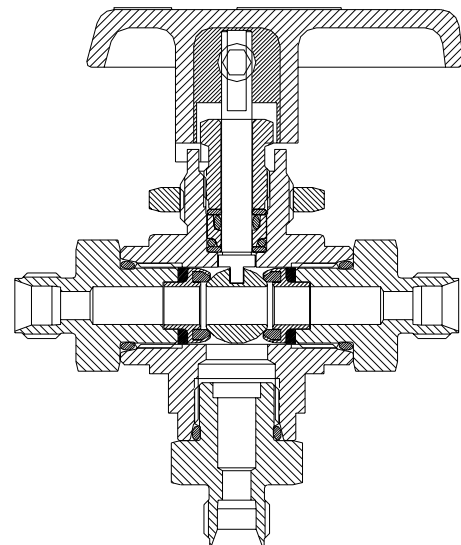

Figure 2: Three-Way B Series Ball Valve with O-Ring Packing Cross Sectional View

DISASSEMBLY

WARNING: MAKE CERTAIN THE SYSTEM IN WHICH THE VALVE IS INSTALLED IS EXHAUSTED OF ALL PRESSURE BEFORE STARTING VALVE REMOVAL. CYCLE THE VALVE TWICE TO REMOVE ANY ENTRAPPED PRESSURE. FAILURE TO DO SO CAN CAUSE DEATH, PERSONAL INJURY AND PROPERTY DAMAGE.

1. Verify that the Ball Valve Maintenance Kit being used is appropriate for the Valve's size and service requirements. Always contact your authorized Parker representative if any questions arise.
2. Remove the Handle by turning the Set Screw counter-clockwise with the following size hex socket wrench.

| | |
|-----------|-------------|
| B2 valves | 5/64 wrench |
| B6 valves | 3/32 wrench |
| B8 valves | 1/8 wrench |
3. Remove the Ball Valve Body from its mounting panel hole, if applicable, by turning the Panel Nut counter-clockwise.
4. Remove the Packing Nut (located directly under the handle) by turning counter-clockwise with the following size hex wrench.

| | |
|-----------|-------------|
| B2 valves | 5/16 wrench |
| B6 valves | 7/16 wrench |
| B8 valves | 1/2 wrench |
5. To perform Packing maintenance, remove the stem assembly from the Body. Discard the two Stem Packing Washers and the Packing.
6. To access the Seats and the Ball, secure the Body at the wrench flats and remove the two port End Connectors, using the appropriate hex wrench.

NOTE: For O-ring Stem Packing models discard the two Stem O-Rings and the Stem Packing Washers. Do not discard the Packing Gland.

| | |
|-----------|---------------|
| B2 valves | 9/16 wrench |
| B6 valves | 3/4 wrench |
| B8 valves | 1-1/16 wrench |

- CAUTION:** Hold the Valve Body by using a finger tip on each End Connector opening to prevent the interior Ball and the Seat components from falling out.
7. Gently remove and discard the two internal Seals and Seats, exercising care not to damage or scratch the Body's interior sealing surfaces or the threads. Remove and save the Ball.
 8. Remove and discard the O-Ring located on each End Connector, exercising care not to damage or scratch the Connectors' sealing surfaces or the threads.

REASSEMBLY OF BALL VALVES WITH PTFE PACKING

1. Make certain all parts are free of dirt or other contamination before starting reassembly of the Valve.
2. Refer to Figures 1 thru 3, as applicable for the Valve's configuration. Place an O-Ring on each End Connector as illustrated in Figure 5, exercise care not to damage or scratch the O-Rings.

NOTE: Mandrels are provided for valves with PTFE end connector seals. For valves with elastomeric end connector seals, a mandrel is not needed.

3. Lightly apply an appropriate lubricant to the End Connectors' threads as consistent with the Valve's service requirements. Always consult your authorized Parker representative if questions arise.
4. Place a Retainer Seal on each of the two Ball Seat Sub-Assemblies which have Seats crimped into their reverse face.
5. Position the End Connectors upright so their O-ring installed end is facing up. Place a Ball Seat Sub-Assembly with Retainer Seal into the boss at the top of each End Connector so the Seat is facing up.
6. For all valve seats except PTFE, apply a small amount of lubricant to the Seat as consistent with the Valve's service requirements. Always contact your authorized Parker representative if questions arise.
7. Apply a small amount of an appropriate lubricant to the Packing Nut and End Connector threads, as consistent with the Valve's service requirements. Always contact your authorized Parker representative if questions arise.
8. Refer to Figure 3. Stack the three Stem Packing components on the Stem in the following order, with the first item being placed at the bottom of the Stem: Packing Washer / Stem Packing / Packing Washer.

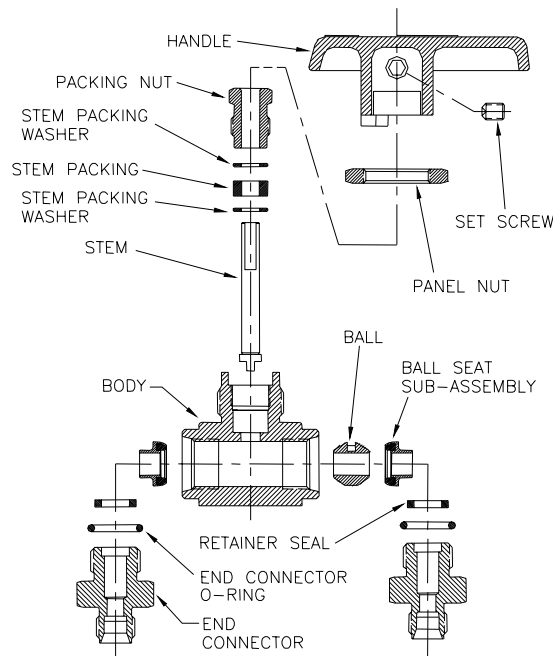

Figure 3: Ball Valve Assembly with PTFE Packing Exploded View

9. While holding the Body in one hand, with the ports vertical, carefully place one End Connector / Seat Retainer Sub-Assembly into the lower Valve body port. Engage this Sub-Assembly in the Body until it is finger tight.
10. Insert the Ball inside the Body, with the slot facing toward the Stem, using a clean wooden dowel of the following diameter:

| | |
|-----------|-----------|
| B2 valves | 9/64 inch |
| B6 valves | 3/16 inch |
| B8 valves | 3/8 inch |

Leave the wooden dowel in the Body to temporarily hold the Ball inside the Seating area.

11. Place the keyed end of the Stem Sub-Assembly through the stem port into the corresponding slot in the Ball. Rotate the wooden dowel to move the Ball slot so it is at the Stem position.
12. Install the lubricated Packing Nut on the Body until it is finger-tight.
13. Secure the Body so that the Stem is vertical.
14. Complete the installation by turning the Packing Nut on the Body clockwise and tightening using the size hex socket torque wrench and torque level specified in the following table.

Packing Nut Tightening Specifications

| Ball Valve Size | Hex Socket Wrench | Torque Level |
|-----------------|-------------------|----------------------|
| B2 | 5/16 inch | 30 In-lbs (3.4 N-m) |
| B6 | 7/16 inch | 70 In-lbs (7.9 N-m) |
| B8 | 1/2 inch | 90 In-lbs (10.2 N-m) |

15. Remove the wooden dowel (if applicable) from the Body after the Packing Nut is properly tightened on the Body.
 16. While holding the Body in one hand, with the ports vertical, carefully place the other End Connector / Seat Retainer Sub-Assembly into the lower Valve body port. Engage this Sub-Assembly in the Body until it is finger tight.
- NOTE:** On 3-way Ball Valves, the bottom port End Connector is assembled just as the two (primary) End Connectors, except no Ball Seat mounting elements are involved. Refer to Figure 2.
17. Close the Valve. This is required to avoid Seat damage during the following tightening of the End Connectors.

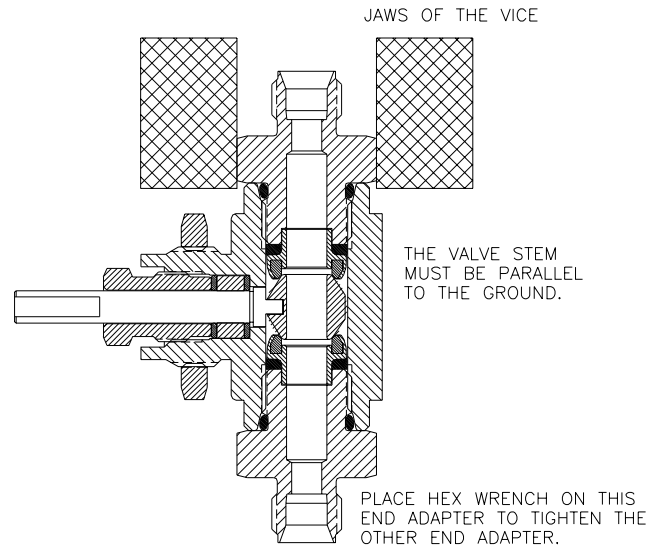

Figure 4: Position of Valve Body during tightening of End Connectors

18. Secure one End Connector (not the Valve Body) of the Ball Valve so that the Stem is horizontal, as illustrated in Figure 4.

WARNING: It is IMPERATIVE that two (2) conditions exist during the tightening of the End Connectors. Failure to adhere to these two conditions may result in damaging the Valve during tightening of the End Connectors.

- 1) The Stem **MUST NOT** move.
- 2) The Ball **MUST** be capable of limited **FREE MOVEMENT** while inside the Body.

19. Tighten the End Connectors in accordance with the specifications in the following table using the following size hex socket torque wrench.

| | |
|-----------|-------------|
| B2 valves | 9/16 inch |
| B6 valves | 3/4 inch |
| B8 valves | 1-1/16 inch |

NOTE: The bottom port End Connector on Three-Way Ball Valves is also torqued as instructed.

Ball Valve Port End Connector Torque Requirements

| Valve Size | Valve Body Material | |
|------------|---|--|
| | Brass or Alloy 400 | Stainless Steel or Hastelloy |
| B2 | 75 In-lbs (8.5 N-m) 6.3 Ft-lbs (8.5 N-m) | 100 In-lbs (11.3 N-m) 8.3 Ft-lbs (11.3 N-m) |
| B6 | 204 In-lbs (23.1 N-m) 17 Ft-lbs (23.1 N-m) | 348 In-lbs (39.3 N-m) 29 Ft-lbs (39.3 N-m) |
| B8 | 456 In-lbs (51.5 N-m) 38 Ft-lbs (51.5 N-m) | 660 Ft-lbs (74.6 N-m) 55 Ft-lbs (74.6 N-m) |

20. Turn the Stem through at least one (1) "Close and Open" cycle to verify proper operation of the Stem.

CAUTION: Rebuild any Valve exhibiting rough or irregular Stem operation. Always consult your authorized Parker representative if questions arise.

21. Install the Ball Valve Body in its panel mounting hole, if applicable, by turning the Panel Nut clockwise.

22. Re-install the Handle. Secure by turning the Set-Screw clockwise and tightening to 15 In-lbs (1.7 N-m).
GENTLY SLIDE THE O-RING OVER THE MANDREL IN THIS DIRECTION

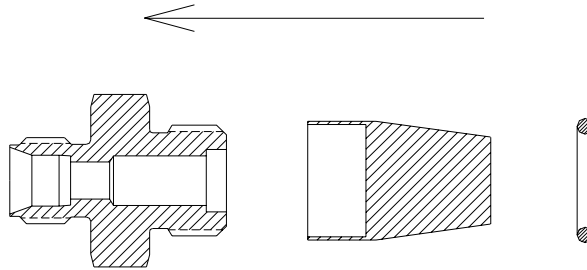

Figure 5: Installing an O-Ring on an End Connector

1. PLACE THE MANDREL OVER THE END CONNECTOR THREAD (ONLY IF O-RING IS PTFE).
2. SLIDE THE O-RING SLOWLY AND GENTLY OVER THE THREADS/MANDREL.
3. PLACE THE O-RING UP AGAINST THE END CONNECTOR'S HEX FACE SECTION.
4. IN THE CASE OF A TEFLON O-RING, PULLING THE MANDREL AWAY FROM THE END CONNECTOR WILL ALLOW THE O-RING TO FALL IN THE SEALING SLOT NEXT TO THE END CONNECTOR'S HEX SECTION.

REASSEMBLY OF BALL VALVES WITH O-RING STEM PACKING

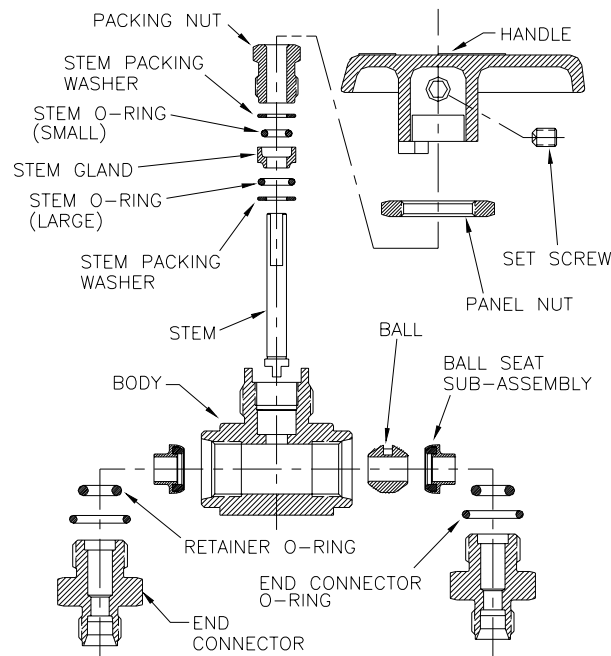

Figure 6: Ball Valve with O-Ring Stem Packing Assembly Exploded View

1. Perform steps 1 thru 7 of the standard PTFE Packing Ball Valve Reassembly instructions.
2. Lightly apply an appropriate lubricant on the two new Stem Packing O-Rings, as consistent with the Valve's service requirements. Always consult your authorized Parker representative if questions arise.
3. Refer to Figure 6. Stack the five Stem Packing components on the Stem in the following order, with the first item being placed at the bottom of the Stem:
 - new Packing Washer
 - new (large) O-Ring (lubricated)
 - Stem Packing Gland, with the raised nipple section facing down toward the bottom of the Stem.
 - new (small) O-Ring (lubricated)
 - new Packing Washer.
4. Perform steps 9 thru 22 of the standard PTFE Packing Ball Valve Reassembly instructions.

REASSEMBLY OF BALL VALVES WITH LIVE LOADED PTFE PACKING

1. Perform steps 1 thru 7 of the standard PTFE Packing Ball Valve Reassembly instructions.
2. Refer to Figure 7, 8 or 9 Stack the five Stem Packing components on the Stem in the following order, with the first item being placed at the bottom of the Stem:

- new Packing Washer
- new Packing (Bevel Down)
- new Packing Washer
- new Live Loaded Washer(Bevel Up)
- new Live Loaded Washer(Bevel Down)
- new Packing Washer

For B2 (Figure 7)

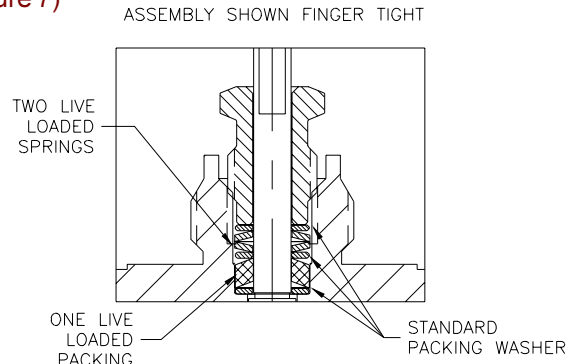

Figure 7

- new Packing Washer
- new Packing (Bevel Down)
- new Packing (Bevel Down)
- new Packing Washer
- new Live Loaded Washer(Bevel Up)
- new Live Loaded Washer(Bevel Down)
- new Packing Washer

For B6 (Figure 8)

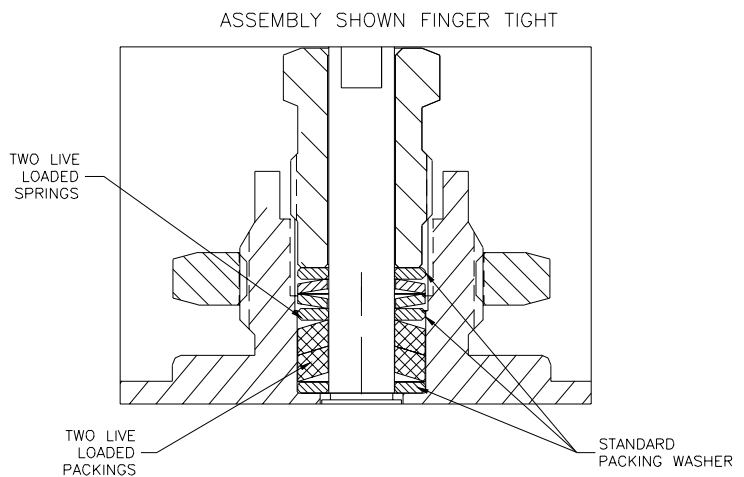

Figure 8

- new Packing Washer
- new Packing (Bevel Down)
- new Packing (Bevel Down)
- new Packing Washer
- new Live Loaded Washer(Bevel Up)
- new Live Loaded Washer(Bevel Down)
- new Live Loaded Washer(Bevel Up)
- new Live Loaded Washer(Bevel Down)
- new Packing Washer

For B8 (Figure 9)

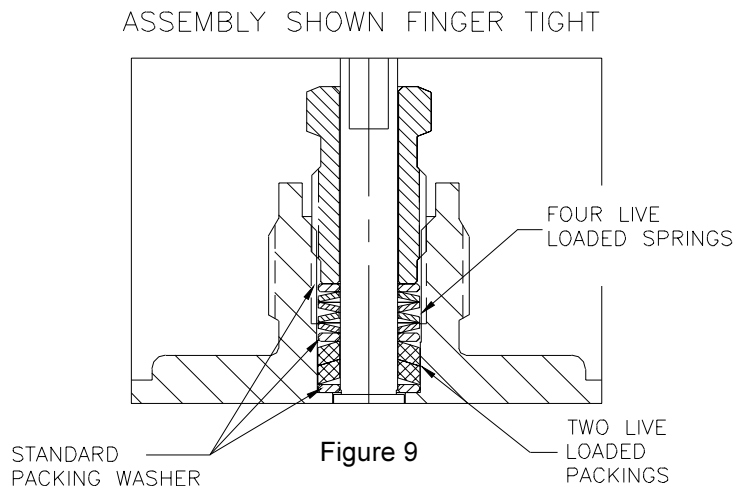

Figure 9

3. Perform steps 9 thru 22 of the standard PTFE Packing Ball Valve Reassembly instructions.

VALVE CONNECTOR MAKE-UP INSTRUCTIONS

MALE AND FEMALE PIPE PORTS

Wrench flats are provided on the Valve Body. It is recommended a smooth-jawed wrench or vise be used to grip the Valve Body.

1. On the male threaded part of the connection, apply a high quality pipe joint compound or PTFE tape made for this purpose. When PTFE tape is used, it is recommended two full turns of tape be applied. PTFE tape should not be overhanging or covering the first thread
2. Engage the Valve and the other component part together, until hand-tight.
3. With a proper wrench, holding both the Valve and the component part, continue to tighten to achieve a leak-tight joint.

ULTRASEAL CONNECTIONS

1. Insert the proper O-Ring into the UltraSeal fitting's O-Ring groove. Position the UltraSeal gland sealing face against the O-Ring, and then advance the Nut to a finger-tight position.
2. A positive seal is obtained by advancing the Nut no less than 1/4 turn from the finger-tight position. Proper UltraSeal make-up is achieved when a sharp rise in required application torque occurs, which indicates proper seal face contact and O-Ring seal compression into the UltraSeal groove.

VACUSEAL CONNECTIONS

1. A positive seal is obtained by advancing the Nut 1/8 turn from the finger-tight position.
2. A new gasket should be installed upon each fitting re-make to insure system pressure integrity.

TUBE FITTING CONNECTIONS

1. Insert the tube into the Valve port until the tube bottoms out in the Valve Body. Care should be exercised to insure the tube is properly aligned with the Valve Body and port.
2. Normal make-up for US Customary port sizes 1 thru 3 (1/16 thru 3/16 inch) and SI port sizes 2 thru 4 (2 thru 4 mm) is 3/4 turn from finger tight. Normal make-up for US Customary port sizes 4 thru 16 (1/4 thru 1 inch) and SI port sizes 5 thru 25 (5 thru 25 mm) is 1 1/4 turn from finger tight. For larger port sizes consult Parker Ferrule Presetting Tool Instructions.

PLEASE FOLLOW THE ABOVE DIRECTIONS FOR COUNTING THE NUMBER OF TURNS FOR PROPER FITTING MAKE-UP. DO NOT MAKE-UP TUBE FITTINGS BY TORQUE OR "FEEL". VARIABLES SUCH AS TUBING AND FITTING TOLERANCES, TUBE WALL THICKNESS, AND THE LUBRICITY OF NUT LUBRICANTS CAN RESULT IN AN IMPROPERLY ASSEMBLED TUBE FITTING CONNECTION.

A -Two ferrule A-LOK[®] compression port



Z -Single ferrule CPI[™] compression port



F -ANSI/ASME B1.20.1 Internal pipe threads



V -VacuSeal face seal port



Q -UltraSeal face seal port



M -ANSI/ASME B1.20.1 External pipe threads



WARNING

FAILURE OR IMPROPER SELECTION OR IMPROPER USE OF THE PRODUCTS AND/OR SYSTEMS DESCRIBED HEREIN OR RELATED ITEMS CAN CAUSE DEATH, PERSONAL INJURY AND PROPERTY DAMAGE.

This document and other information from Parker Hannifin Corporation, its subsidiaries and authorized distributors provide product and/or system options for further investigation by users having technical expertise. It is important that you analyze all aspects of your application and review the information concerning the product or system in the current product catalog. Due to the variety of operating conditions and applications for these products or systems, the user, through its own analysis and testing, is solely responsible for making the final selection of the products and systems and assuring that all performance, safety and warning requirements of the application are met.

The products described herein, including without limitation, product features, specifications, designs, availability and pricing, are subject to change by Parker Hannifin Corporation and its subsidiaries at any time without notice.

ALL PARKER VALVES MUST PASS A RIGID OPERATIONAL AND LEAKAGE TEST BEFORE LEAVING THE FACTORY. IT IS RECOMMENDED AFTER ANY REASSEMBLY, THE VALVE SHOULD BE TESTED BY THE USER FOR OPERATION AND LEAKAGE. IF THESE INSTRUCTIONS ARE NOT FULLY COMPLIED WITH, THE REPAIRED PRODUCT MAY FAIL AND CAUSE DAMAGE TO PROPERTY OR INJURY TO PERSONS. PARKER HANNIFIN CANNOT ASSUME RESPONSIBILITY FOR PERFORMANCE OF A CUSTOMER SERVICED VALVE.



MI-108 Revision -

Parker Hannifin Corporation
Instrumentation Valve Division
2651 Alabama Highway 21 North
Jacksonville, AL 36265-9681
USA
Phone: (256) 435-2130
Fax: (256) 435-7718
www.parker.com/IVD