



5-Phase Stepping Motor Unit

CRK Series

OPERATING MANUAL



Thank you for purchasing an Oriental Motor product.

This Operating Manual describes product handling procedures and safety precautions.

- Please read it thoroughly to ensure safe operation.
- Always keep the manual where it is readily available.

Table of contents

1	Introduction	2	6	Connection	32
2	Safety precautions	4	6.1	Connection example.....	32
3	Precautions for use	7	6.2	Applicable contacts and connector housings	35
4	Preparation.....	9	6.3	Connecting the power supply ...	37
4.1	Checking the product	9	6.4	Explanation of I/O signals.....	37
4.2	Combinations of motors and drivers	10	6.5	Timing chart.....	41
4.3	Names and functions of parts ...	16	7	Setting.....	42
5	Installation	18	7.1	Step angle	42
5.1	Location for installation	18	7.2	Pulse input modes	44
5.2	Installing the motor.....	18	7.3	Smooth drive function.....	44
5.3	Installing a load	21	7.4	Motor current	45
5.4	Permissible overhung load and permissible thrust load	23	8	Inspection.....	49
5.5	Installing the driver.....	26	9	Troubleshooting and remedial actions	50
5.6	Installing and wiring in compliance with EMC Directive.....	29	10	Options (sold separately)	53

1 Introduction

■ Before using the product

The product described in this manual has been designed and manufactured for use in general industrial machinery, and must not be used for any other purpose. For the driver's power supply, use a DC power supply with reinforced insulation on its primary and secondary sides. Oriental Motor Co., Ltd. is not responsible for any damage caused through failure to observe this warning.

■ Overview of the product

The **CRK** series is a unit product comprised of an open-case microstep driver equipped with smooth drive function and a five-phase stepping motor or various geared motors designed for high torque and low vibration. The smooth drive function allows microstep drive to be performed automatically within the driver without having to change the pulse setting, thereby enabling low vibration, low noise operation.

■ Standards and CE Marking

This product is recognized by UL and certified by CSA, and bears the CE Marking (EMC Directive) in compliance with the EN Standards.

• Applicable Standards

Motor

Motor type [unit: mm (in.)]		Applicable Standards*5	Certification Body	Standard File No.	CE Marking
High-resolution type		UL 60950-1 CSA C22.2 No.60950-1	UL	E208200	EMC Directive*6
High-torque type		UL 60950 CSA C22.2 No.60950			
Standard type TH geared type PL geared type PN geared type Harmonic geared type	□20 (0.79)*1 □28 (1.10)*2 □30 (1.18)*1 □60 (2.36)*3	UL 60950 CSA C22.2 No.60950	E208200		
	□42 (1.65) □60 (2.36)*4	UL 1004, UL 2111 UL 1004, UL 2111 CSA C22.2 No.77 CSA C22.2 No.100	E64199		

*1 Harmonic geared type only.

*2 **TH** geared type and **PN** geared type only.

*3 **CRK566H□PB** only.

*4 Excluding **CRK566H□PB**.

*5 Approval conditions for UL 60950, UL 60950-1: Class III equipment, SELV circuit, Pollution degree 2.

*6 Oriental Motor declares compliance with the EMC Directives based on motor and driver combinations.

Driver

Applicable Standards* ¹	Certification Body	Standard File No.	CE Marking
UL 60950-1* ² CSA C22.2 No.60950-1* ²	UL	E208200	EMC Directive* ³

*1 Approval conditions for UL 60950, UL 60950-1: Class III equipment, SELV circuit, Pollution degree 2

*2 Excluding CRD5128PB.

*3 Oriental Motor declares compliance with the EMC Directives based on motor and driver combinations.

- **Low Voltage Directive**

This product is not subject to the EC's Low Voltage Directive because its input power supply voltage is 24 VDC. However, the user is advised to perform the following actions when conducting product installation and connection.

- This product is designed for use within machinery, so it should be installed within an enclosure.
- For the driver's power supply, use a DC power supply with reinforced insulation on its primary and secondary sides.

- **EMC Directive (89/336/EEC, 92/31/EEC)**

This product bears the CE mark under the conditions specified in "Example of motor and driver installation and wiring" on p.31.



Be sure to conduct EMC measures with the product assembled in your equipment by referring to 5.6 "Installing and wiring in compliance with EMC Directive" on p.29.

■ Hazardous substances

RoHS (Directive 2002/95/EC 27Jan.2003) compliant

2 Safety precautions

The precautions described below are intended to prevent danger or injury to the user and other personnel through safe, correct use of the product. Use the product only after carefully reading and fully understanding these instructions.

 Warning	Handling the product without observing the instructions that accompany a “Warning” symbol may result in serious injury or death.
 Caution	Handling the product without observing the instructions that accompany a “Caution” symbol may result in injury or property damage.
Note	The items under this heading contain important handling instructions that the user should observe to ensure safe use of the product.

 **Warning**

General

- Do not use the product in explosive or corrosive environments, in the presence of flammable gases, locations subjected to splashing water, or near combustibles. Doing so may result in fire or injury.
- Assign qualified personnel the task of installing, wiring, operating/controlling, inspecting and troubleshooting the product. Failure to do so may result in fire or injury.
- If this product is used in an elevator application, be sure to provide a measure for the position retention of moving parts. The motor loses its holding torque when the power supply is turned off. Failure to provide such a measure may cause the moving parts to fall, resulting in injury or damage to the equipment.

Installation

- Install the motor and driver in their enclosures in order to prevent injury.

Connection

- Keep the driver’s power supply input voltage within the specified range to avoid fire.
- For the driver’s power supply, use a DC power supply with reinforced insulation on its primary and secondary sides. Failure to do so may result in electric shock.
- Connect the cables securely according to the wiring diagram in order to prevent fire.
- Do not forcibly bend, pull or pinch the power supply cable or motor cable. Doing so may result in fire.

Operation

- Turn off the driver power supply in the event of a power failure, or the motor may suddenly start when the power is restored and may cause injury or damage to equipment.
- Do not turn the A.W.OFF input to ON while the motor is operating. The motor will stop and lose its holding ability, which may result in injury or damage to the equipment.

Repair, disassembly and modification

- Do not disassemble or modify the motor or driver. This may cause injury. Refer all such internal inspections and repairs to the branch or sales office from which you purchased the product.



Caution

General

- Do not use the motor and driver beyond their specifications, or injury or damage to equipment may result.
- Keep your fingers and objects out of the openings in the motor and driver, or fire or injury.
- Do not touch the motor or driver during operation or immediately after stopping. The surfaces are hot and may cause a skin burn(s).
- If the power supply cable or motor cable connected the driver are forcibly bent or pulled, the driver will receive stress and may suffer damage.

Transportation

- Do not hold the motor output shaft or motor cable. This may cause injury.

Installation

- Keep the area around the motor and driver free of combustible materials in order to prevent fire or a skin burn(s).
- To prevent the risk of damage to equipment, leave nothing around the motor and driver that would obstruct ventilation.
- Provide a cover over the rotating parts (output shaft) of the motor to prevent injury.

Operation

- Use a motor and driver only in the specified combination. An incorrect combination may cause a fire.
- Provide an emergency stop device or emergency stop circuit external to the equipment so that the entire equipment will operate safely in the event of a system failure or malfunction. Failure to do so may result in injury.
- Before supplying power to the driver, turn all input signals to the driver to OFF. Otherwise, the motor may start suddenly and cause injury or damage to equipment.

2 Safety precautions

- Provide a cover over the rotating parts (output shaft) of the motor to prevent injury.
- Before moving the motor directly with the hands (as in the case of manual positioning), confirm that the driver A.W.OFF input is ON to prevent injury.
- Immediately when trouble has occurred, stop running and turn off the driver power supply. Failure to do so may result in fire or injury.

Disposal

- To dispose of the motor and driver, disassemble it into parts and components as much as possible and dispose of individual parts/components as industrial waste.

3 Precautions for use

This section covers limitations and requirements the user should consider when using the **CRK** series.

- **Conduct the insulation resistance measurement or withstand voltage test separately on the motor and the driver.**

Conducting the insulation resistance measurement or withstand voltage test with the motor and driver connected may result in injury or damage to equipment.

- **Do not apply an overhung load and thrust load in excess of the specified permissible limit.**

Be sure to operate the motor within the specified permissible limit of overhung load and thrust load. Operating it under an excessive overhung load and thrust load may damage the motor bearings (ball bearings). See p.23 for details.

- **Operate the motor with a surface temperature not exceeding 100 °C (212 °F).**

The motor casing's surface temperature may exceed 100 °C (212 °F) under certain conditions (ambient temperature, operating speed, duty cycle, etc.). Keeping the surface temperature of the motor casing below 100 °C (212 °F) will also maximize the life of the motor bearings (ball bearings).

When a harmonic geared type is used, make sure the gear case temperature is kept at 70 °C (158 °F) or below to prevent degradation of grease applied to the gear.

- **Maximum static torque at excitation**

Maximum static torque at excitation represents a value obtained when the motor is excited using the rated current. When the motor is combined with a dedicated driver, the maximum static torque at excitation drops to approximately 50% due to the current cutback function that suppresses the rise in motor temperature in a standstill state. Acceleration and operation at the maximum static torque at excitation is possible in start-up, but it only has approximately 50% holding power after it has stopped. When selecting a motor for your application, consider the fact that the holding power will be reduced to approximately 50% after the motor has stopped.

- **Preventing electrical noise**

See 5.6 “Installing and wiring in compliance with EMC Directive” on p.29 for measures with regard to noise.

- **Regeneration**

When a large inertial load is operated at high speed, regenerative energy will generate and increase the power supply voltage, which can damage the driver. Review the operating condition and make sure regenerative voltage will not generate.

- Geared type motors

Backlash

The **TH** gear output shaft is subject to backlash of 10 to 60 minutes. As for the **PL** gear output shaft is subject to backlash of 15 to 35 minutes. As for the **PN** gear output shaft is subject to backlash of 2 to 3 minutes. Backlash refers to the looseness at the gear output shaft, as generated when the input side of the gear is fixed. To reduce the effect of backlash, positioning should be from one direction only either from the CW direction or the CCW direction.

Maximum torque

Always operate geared types with loads not exceeding their maximum torque. If a geared type is operated with a load exceeding the maximum torque, the gear will be damaged.

Rotating direction of the gear output shaft

The relationship between the rotating direction of the motor shaft and that of the gear output shaft changes as follows, depending on the gear type and gear ratio.

Gear type	Gear ratio	Rotating direction (Relative to the motor rotation direction)			
		Motor size [mm (in.)]			
		20 (0.79)	28 (1.10) 30 (1.18)	42 (1.65)	60 (2.36)
TH gear	3.6:1 7.2:1 10:1	-	Opposite direction	Same direction	
	20:1 30:1	-	Same direction	Opposite direction	
PL gear PN gear	5:1 7.2:1 10:1 25:1 36:1 50:1	-	Same direction		
Harmonic gear	50:1 100:1	Opposite direction			

Grease of geared motor

On rare occasions, a small amount of grease may ooze out from the geared motor. If there is concern over possible environmental damage resulting from the leakage of grease, check for grease stains during regular inspections. Alternatively, install an oil pan or other device to prevent leakage from causing further damage. Oil leakage may lead to problems in the customer's equipment or products.

4 Preparation

This section covers the points to be checked along with the names and functions of the respective parts.

4.1 Checking the product

Verify that the items listed below are included.

Report any missing or damaged items to the branch or sales office from which you purchased the product. See 4.2 “Combinations of motors and drivers” on p.10 for the motor and driver combinations.

- Motor 1 unit
- Driver 1 unit
- Connector leads 0.6 m (2 ft.) 1 pc.
(Connector leads are supplied only with unit products of a connector connection system.)
- Operating manual (this manual) 1 copy
- Connector housing/contact 1 set (packed in a bag)

Driver model	Connector	Housing (Molex)	Contact (Molex)
CRD5103PB CRD5107PB CRD5107HPB CRD5114PB	For power supply	1 pc. 51103-0200 (2 poles)	19 pcs. 50351-8100
CRD5103P CRD5107P CRD5107HP CRD5114P	For I/O signals	1 pc. 51103-1200 (12 poles)	
	For motor	1 pc. 51103-0500 (5 poles)	
CRD5128PB	For power supply	1 pc. 51067-0200 (2 poles)	2 pcs. 50217-9101
	For I/O signals	1 pc. 51103-1200 (12 poles)	12 pcs. 50351-8100
	For motor	1 pc. 51067-0500 (5 poles)	5 pcs. 50217-9101

Note

When removing the driver from the conductive protection bag, make sure your hands are not charged with static electricity. This is to prevent damage to the driver due to static electricity.

4.2 Combinations of motors and drivers

■ High-resolution type

Unit model		Motor model		Driver model
Single shaft	Double shaft	Single shaft	Double shaft	
CRK523PMAPB	CRK523PMBPB	PK523PMA	PK523PMB	CRD5103PB
CRK524PMAPB	CRK524PMBPB	PK524PMA	PK524PMB	
CRK525PMAPB	CRK525PMBPB	PK525PMA	PK525PMB	
CRK523HPMAPB	CRK523HPMBPB	PK523HPMA	PK523HPMB	CRD5107HPB
CRK524HPMAPB	CRK524HPMBPB	PK524HPMA	PK524HPMB	
CRK525HPMAPB	CRK525HPMBPB	PK525HPMA	PK525HPMB	
CRK544PMAPB	CRK544PMBPB	PK544PMA	PK544PMB	CRD5107PB
CRK546PMAPB	CRK546PMBPB	PK546PMA	PK546PMB	
CRK564PMAPB	CRK564PMBPB	PK564PMA	PK564PMB	CRD5114PB
CRK566PMAPB	CRK566PMBPB	PK566PMA	PK566PMB	
CRK569PMAPB	CRK569PMBPB	PK569PMA	PK569PMB	
CRK523PMAP	CRK523PMBP	PK523PMA	PK523PMB	CRD5103P
CRK524PMAP	CRK524PMBP	PK524PMA	PK524PMB	
CRK525PMAP	CRK525PMBP	PK525PMA	PK525PMB	
CRK523HPMAP	CRK523HPMBP	PK523HPMA	PK523HPMB	CRD5107HP
CRK524HPMAP	CRK524HPMBP	PK524HPMA	PK524HPMB	
CRK525HPMAP	CRK525HPMBP	PK525HPMA	PK525HPMB	
CRK544PMAP	CRK544PMBP	PK544PMA	PK544PMB	CRD5107P
CRK546PMAP	CRK546PMBP	PK546PMA	PK546PMB	
CRK564PMAP	CRK564PMBP	PK564PMA	PK564PMB	CRD5114P
CRK566PMAP	CRK566PMBP	PK566PMA	PK566PMB	
CRK569PMAP	CRK569PMBP	PK569PMA	PK569PMB	

■ High-torque type

Unit model		Motor model		Driver model
Single shaft	Double shaft	Single shaft	Double shaft	
CRK513PAPB	CRK513PBPB	PK513PA	PK513PB	CRD5103PB
CRK523PAPB	CRK523PBPB	PK523PA	PK523PB	
CRK525PAPB	CRK525PBPB	PK525PA	PK525PB	
CRK523HPAPB	CRK523HPBPB	PK523HPA	PK523HPB	CRD5107HPB
CRK525HPAPB	CRK525HPBPB	PK525HPA	PK525HPB	
CRK544PAPB	CRK544PBPB	PK544PA	PK544PB	CRD5107PB
CRK546PAPB	CRK546PBPB	PK546PA	PK546PB	
CRK513PAP	CRK513PBP	PK513PA	PK513PB	CRD5103P
CRK523PAP	CRK523PBP	PK523PA	PK523PB	
CRK525PAP	CRK525PBP	PK525PA	PK525PB	
CRK523HPAP	CRK523HPBP	PK523HPA	PK523HPB	CRD5107HP
CRK525HPAP	CRK525HPBP	PK525HPA	PK525HPB	
CRK544PAP	CRK544PBP	PK544PA	PK544PB	CRD5107P
CRK546PAP	CRK546PBP	PK546PA	PK546PB	

■ Standard type

Unit model		Motor model		Driver model
Single shaft	Double shaft	Single shaft	Double shaft	
CRK543APB	CRK543BPB	PK543NAW	PK543NBW	CRD5107PB
CRK544APB	CRK544BPB	PK544NAW	PK544NBW	
CRK545APB	CRK545BPB	PK545NAW	PK545NBW	
CRK564APB	CRK564BPB	PK564NAW	PK564NBW	CRD5114PB
CRK566APB	CRK566BPB	PK566NAW	PK566NBW	
CRK569APB	CRK569BPB	PK569NAW	PK569NBW	CRD5128PB
CRK566HAPB	CRK566HBPB	PK566HNAW	PK566HNBW	
CRK569HAPB	CRK569HBPB	PK569HNAW	PK569HNBW	
CRK543AP	CRK543BP	PK543NAW	PK543NBW	CRD5107P
CRK544AP	CRK544BP	PK544NAW	PK544NBW	
CRK545AP	CRK545BP	PK545NAW	PK545NBW	
CRK564AP	CRK564BP	PK564NAW	PK564NBW	CRD5114P
CRK566AP	CRK566BP	PK566NAW	PK566NBW	
CRK569AP	CRK569BP	PK569NAW	PK569NBW	

■ TH geared type

Unit model		Motor model		Driver model
Single shaft	Double shaft	Single shaft	Double shaft	
CRK523PAPB-T7.2	CRK523PBPB-T7.2	PK523PA-T7.2	PK523PB-T7.2	CRD5103PB
CRK523PAPB-T10	CRK523PBPB-T10	PK523PA-T10	PK523PB-T10	
CRK523PAPB-T20	CRK523PBPB-T20	PK523PA-T20	PK523PB-T20	
CRK523PAPB-T30	CRK523PBPB-T30	PK523PA-T30	PK523PB-T30	
CRK543APB-T3.6	CRK543BPB-T3.6	PK543AW-T3.6	PK543BW-T3.6	CRD5107PB
CRK543APB-T7.2	CRK543BPB-T7.2	PK543AW-T7.2	PK543BW-T7.2	
CRK543APB-T10	CRK543BPB-T10	PK543AW-T10	PK543BW-T10	
CRK543APB-T20	CRK543BPB-T20	PK543AW-T20	PK543BW-T20	
CRK543APB-T30	CRK543BPB-T30	PK543AW-T30	PK543BW-T30	CRD5114PB
CRK564APB-T3.6	CRK564BPB-T3.6	PK564AW-T3.6	PK564BW-T3.6	
CRK564APB-T7.2	CRK564BPB-T7.2	PK564AW-T7.2	PK564BW-T7.2	
CRK564APB-T10	CRK564BPB-T10	PK564AW-T10	PK564BW-T10	
CRK564APB-T20	CRK564BPB-T20	PK564AW-T20	PK564BW-T20	CRD5103P
CRK523PAP-T7.2	CRK523PBP-T7.2	PK523PA-T7.2	PK523PB-T7.2	
CRK523PAP-T10	CRK523PBP-T10	PK523PA-T10	PK523PB-T10	
CRK523PAP-T20	CRK523PBP-T20	PK523PA-T20	PK523PB-T20	
CRK523PAP-T30	CRK523PBP-T30	PK523PA-T30	PK523PB-T30	CRD5107P
CRK543AP-T3.6	CRK543BP-T3.6	PK543AW-T3.6	PK543BW-T3.6	
CRK543AP-T7.2	CRK543BP-T7.2	PK543AW-T7.2	PK543BW-T7.2	
CRK543AP-T10	CRK543BP-T10	PK543AW-T10	PK543BW-T10	
CRK543AP-T20	CRK543BP-T20	PK543AW-T20	PK543BW-T20	CRD5114P
CRK543AP-T30	CRK543BP-T30	PK543AW-T30	PK543BW-T30	
CRK564AP-T3.6	CRK564BP-T3.6	PK564AW-T3.6	PK564BW-T3.6	
CRK564AP-T7.2	CRK564BP-T7.2	PK564AW-T7.2	PK564BW-T7.2	
CRK564AP-T10	CRK564BP-T10	PK564AW-T10	PK564BW-T10	CRD5114P
CRK564AP-T20	CRK564BP-T20	PK564AW-T20	PK564BW-T20	
CRK564AP-T30	CRK564BP-T30	PK564AW-T30	PK564BW-T30	

■ PL geared type

Unit model		Motor model		Driver model
Single shaft	Double shaft	Single shaft	Double shaft	
CRK545APB-P5	CRK545BPB-P5	PK545AW-P5	PK545BW-P5	CRD5107PB
CRK545APB-P7.2	CRK545BPB-P7.2	PK545AW-P7.2	PK545BW-P7.2	
CRK545APB-P10	CRK545BPB-P10	PK545AW-P10	PK545BW-P10	
CRK543APB-P25	CRK543BPB-P25	PK543AW-P25	PK543BW-P25	
CRK543APB-P36	CRK543BPB-P36	PK543AW-P36	PK543BW-P36	
CRK543APB-P50	CRK543BPB-P50	PK543AW-P50	PK543BW-P50	
CRK566APB-P5	CRK566BPB-P5	PK566AW-P5	PK566BW-P5	CRD5114PB
CRK566APB-P7.2	CRK566BPB-P7.2	PK566AW-P7.2	PK566BW-P7.2	
CRK566APB-P10	CRK566BPB-P10	PK566AW-P10	PK566BW-P10	
CRK564APB-P25	CRK564BPB-P25	PK564AW-P25	PK564BW-P25	
CRK564APB-P36	CRK564BPB-P36	PK564AW-P36	PK564BW-P36	
CRK564APB-P50	CRK564BPB-P50	PK564AW-P50	PK564BW-P50	
CRK545AP-P5	CRK545BP-P5	PK545AW-P5	PK545BW-P5	CRD5107P
CRK545AP-P7.2	CRK545BP-P7.2	PK545AW-P7.2	PK545BW-P7.2	
CRK545AP-P10	CRK545BP-P10	PK545AW-P10	PK545BW-P10	
CRK543AP-P25	CRK543BP-P25	PK543AW-P25	PK543BW-P25	
CRK543AP-P36	CRK543BP-P36	PK543AW-P36	PK543BW-P36	
CRK543AP-P50	CRK543BP-P50	PK543AW-P50	PK543BW-P50	
CRK566AP-P5	CRK566BP-P5	PK566AW-P5	PK566BW-P5	CRD5114P
CRK566AP-P7.2	CRK566BP-P7.2	PK566AW-P7.2	PK566BW-P7.2	
CRK566AP-P10	CRK566BP-P10	PK566AW-P10	PK566BW-P10	
CRK564AP-P25	CRK564BP-P25	PK564AW-P25	PK564BW-P25	
CRK564AP-P36	CRK564BP-P36	PK564AW-P36	PK564BW-P36	
CRK564AP-P50	CRK564BP-P50	PK564AW-P50	PK564BW-P50	

■ PN geared type

Unit model		Motor model		Driver model
Single shaft	Double shaft	Single shaft	Double shaft	
CRK523PAPB-N5	CRK523PBPB-N5	PK523PA-N5	PK523PB-N5	CRD5103PB
CRK523PAPB-N7.2	CRK523PBPB-N7.2	PK523PA-N7.2	PK523PB-N7.2	
CRK523PAPB-N10	CRK523PBPB-N10	PK523PA-N10	PK523PB-N10	
CRK544APB-N5	CRK544BPB-N5	PK544AW-N5	PK544BW-N5	CRD5107PB
CRK544APB-N7.2	CRK544BPB-N7.2	PK544AW-N7.2	PK544BW-N7.2	
CRK544APB-N10	CRK544BPB-N10	PK544AW-N10	PK544BW-N10	
CRK566APB-N5	CRK566BPB-N5	PK566AW-N5	PK566BW-N5	CRD5114PB
CRK566APB-N7.2	CRK566BPB-N7.2	PK566AW-N7.2	PK566BW-N7.2	
CRK566APB-N10	CRK566BPB-N10	PK566AW-N10	PK566BW-N10	
CRK564APB-N25	CRK564BPB-N25	PK564AW-N25	PK564BW-N25	
CRK564APB-N36	CRK564BPB-N36	PK564AW-N36	PK564BW-N36	
CRK564APB-N50	CRK564BPB-N50	PK564AW-N50	PK564BW-N50	
CRK523PAP-N5	CRK523PBP-N5	PK523PA-N5	PK523PB-N5	CRD5103P
CRK523PAP-N7.2	CRK523PBP-N7.2	PK523PA-N7.2	PK523PB-N7.2	
CRK523PAP-N10	CRK523PBP-N10	PK523PA-N10	PK523PB-N10	
CRK544AP-N5	CRK544BP-N5	PK544AW-N5	PK544BW-N5	CRD5107P
CRK544AP-N7.2	CRK544BP-N7.2	PK544AW-N7.2	PK544BW-N7.2	
CRK544AP-N10	CRK544BP-N10	PK544AW-N10	PK544BW-N10	
CRK566AP-N5	CRK566BP-N5	PK566AW-N5	PK566BW-N5	CRD5114P
CRK566AP-N7.2	CRK566BP-N7.2	PK566AW-N7.2	PK566BW-N7.2	
CRK566AP-N10	CRK566BP-N10	PK566AW-N10	PK566BW-N10	
CRK564AP-N25	CRK564BP-N25	PK564AW-N25	PK564BW-N25	
CRK564AP-N36	CRK564BP-N36	PK564AW-N36	PK564BW-N36	
CRK564AP-N50	CRK564BP-N50	PK564AW-N50	PK564BW-N50	

■ Harmonic geared type

Unit model		Motor model		Driver model
Single shaft	Double shaft	Single shaft	Double shaft	
CRK513PAPB-H50	CRK513PBPB-H50	PK513PA-H50S	PK513PB-H50S	CRD5103PB
CRK513PAPB-H100	CRK513PBPB-H100	PK513PA-H100S	PK513PB-H100S	
CRK523PAPB-H50	CRK523PBPB-H50	PK523HPA-H50S	PK523HPB-H50S	CRD5107HPB
CRK523PAPB-H100	CRK523PBPB-H100	PK523HPA-H100S	PK523HPB-H100S	
CRK543APB-H50	CRK543BPB-H50	PK543AW-H50S	PK543BW-H50S	CRD5107PB
CRK543APB-H100	CRK543BPB-H100	PK543AW-H100S	PK543BW-H100S	
CRK564APB-H50	CRK564BPB-H50	PK564AW-H50S	PK564BW-H50S	CRD5114PB
CRK564APB-H100	CRK564BPB-H100	PK564AW-H100S	PK564BW-H100S	
CRK513PAP-H50	CRK513PBP-H50	PK513PA-H50S	PK513PB-H50S	CRD5103P
CRK513PAP-H100	CRK513PBP-H100	PK513PA-H100S	PK513PB-H100S	
CRK523PAP-H50	CRK523PBP-H50	PK523HPA-H50S	PK523HPB-H50S	CRD5107HP
CRK523PAP-H100	CRK523PBP-H100	PK523HPA-H100S	PK523HPB-H100S	
CRK543AP-H50	CRK543BP-H50	PK543AW-H50S	PK543BW-H50S	CRD5107P
CRK543AP-H100	CRK543BP-H100	PK543AW-H100S	PK543BW-H100S	
CRK564AP-H50	CRK564BP-H50	PK564AW-H50S	PK564BW-H50S	CRD5114P
CRK564AP-H100	CRK564BP-H100	PK564AW-H100S	PK564BW-H100S	

4.3 Names and functions of parts

This section covers the names and functions of parts in the motor and driver. See the reference page indicated for details on each part.

■ Motor

Illustration shows the PK56□ type.

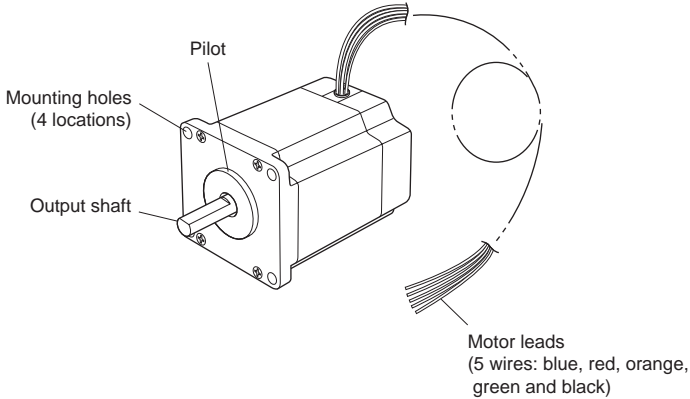

■ Driver

- CRD5103PB, CRD5107PB, CRD5107HPB, CRD5114PB

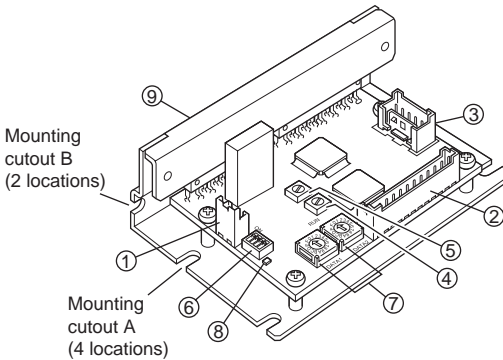

- CRD5103P, CRD5107P, CRD5107HP, CRD5114P

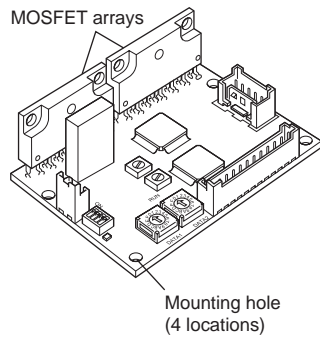

• CRD5128PB

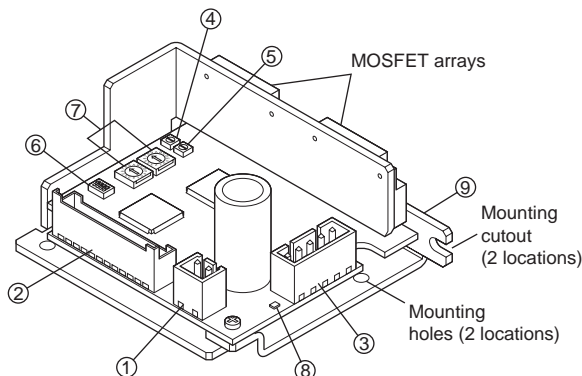

No.	Name	Description
1	Power supply connector (CN1) [p.34]	Connect to a 24 VDC power supply.
2	I/O signals connector (CN2) [p.34]	Connect to I/O signals.
3	Motor connector (CN3) [p.34]	Connect to motor leads.
4	Motor operating current potentiometer (RUN) [p.45]	Set the operating current of the motor. If there is sufficient torque, the current setting can be reduced to suppress increases in motor/driver temperatures. The potentiometer is factory set to [the rated current].
5	Motor standstill current potentiometer (STOP) [p.45]	Set the current when the motor is at a standstill (in the current cutback state)The potentiometer is factory set to [50% of the rated current].
6	Function select switches (1P/2P, OFF/SD, R2/R1) [p.42 to 44]	<ul style="list-style-type: none"> • Pulse input mode select switch (1P/2P): Switch the pulse input mode between 1-pulse input mode and 2-pulse input mode. • Smooth drive function select switch (OFF/SD): Set or cancel the smooth drive function. • Resolution select switch (R2/R1): Switch the reference step angle between R1 and R2.
7	Step angle setting switch (DATA1, DATA2) [p.42]	You can set a desired step angle by selecting it from among the 16 step angles.
8	Power supply input indicator (LED)	This LED remains lit while the power supply is input.
9	Mounting plate [p.26]	-

5 Installation

This chapter explains the installation location and installation methods of the motor and driver, as well as how to install a load. The installation and wiring methods in compliance with the EMC Directive are also explained.

5.1 Location for installation

The motor and driver are designed and manufactured for installation in equipment. Install them in a well-ventilated location that provides easy access for inspection. The location must also satisfy the following conditions:

- Inside an enclosure that is installed indoors (provide vent holes)
- Operating ambient temperature
 - Motor: -10 to $+50$ °C ($+14$ to $+122$ °F) (non-freezing)
 - Harmonic geared type: 0 to $+40$ °C ($+32$ to $+104$ °F) (non-freezing)
 - Driver: 0 to $+40$ °C ($+32$ to $+104$ °F) (non-freezing)
- Operating ambient humidity 85% or less (non-condensing)
- Area that is free of explosive atmosphere or toxic gas (such as sulfuric gas) or liquid
- Area not exposed to direct sun
- Area free of excessive amount of dust, iron particles or the like
- Area not subject to splashing water (rain, water droplets), oil (oil droplets) or other liquids
- Area free of excessive salt
- Area not subject to continuous vibration or excessive shocks
- Area free of excessive electromagnetic noise (from welders, power machinery, etc.)
- Area free of radioactive materials, magnetic fields or vacuum

5.2 Installing the motor

■ Installation direction

The motor can be installed in any direction.

■ Installation method

Install the motor onto an appropriate flat metal plate having excellent vibration resistance and heat conductivity.

When installing the motor, secure it with four bolts (not supplied) through the four mounting holes provided. Do not leave a gap between the motor and metal plate.

Note

Insert the pilot located on the motor's installation surface into the mounting plate's.

Installation method A

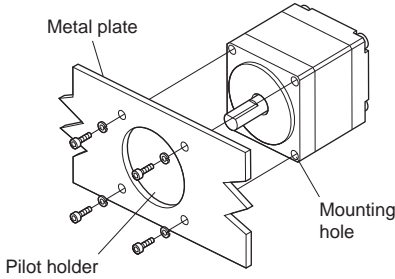

Installation method B

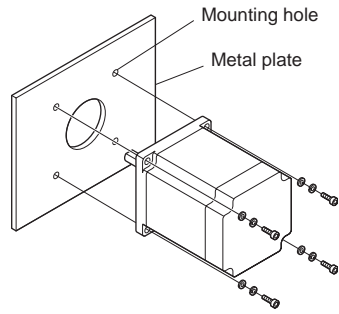

Bolt size, tightening torque and installation method

Motor model		Bolt size	Tightening torque [N·m (oz-in)]	Effective depth of bolt [mm (in.)]	Installation method
Single shaft	Double shaft				
PK513PA	PK513PB	M2	0.25 (35)	2.5 (0.098)	A
PK523PA	PK523PB	M2.5	0.5 (71)		
PK525PA	PK525PB				
PK523HPA	PK523HPB				
PK525HPA	PK525HPB				
PK523PMA	PK523PMB				
PK524PMA	PK524PMB				
PK525PMA	PK525PMB				
PK523HPMA	PK523HPMB				
PK524HPMA	PK524HPMB				
PK525HPMA	PK525HPMB				
PK544PA	PK544PB	M3	1 (142)	4.5 (0.177)	
PK546PA	PK546PB				
PK544PMA	PK544PMB				
PK546PMA	PK546PMB				
PK543NAW	PK543NBW				
PK544NAW	PK544NBW				
PK545NAW	PK545NBW				
PK564PMA	PK564PMB	M4	2 (280)	-	B
PK566PMA	PK566PMB				
PK569PMA	PK569PMB				
PK564NAW	PK564NBW				
PK566NAW	PK566NBW				
PK569NAW	PK569NBW				
PK566HNAW	PK566HNBW				
PK569HNAW	PK569HNBW				

5 Installation

Motor model*		Bolt size	Tightening torque [N·m (oz-in)]	Effective depth of bolt [mm (in.)]	Installation method
Single shaft	Double shaft				
PK523PA-T□	PK523PB-T□	M2.5	0.5 (71)	4 (0.157)	A
PK543AW-T□	PK543BW-T□	M4	2 (280)	8 (0.315)	
PK564AW-T□	PK564BW-T□				
PK545AW-P□	PK545BW-P□				
PK543AW-P□	PK543BW-P□				
PK566AW-P□	PK566BW-P□	M5	2.5 (350)	10 (0.394)	
PK564AW-P□	PK564BW-P□				
PK523PA-N□	PK523PB-N□	M3	1 (142)	6 (0.236)	
PK544AW-N□	PK544BW-N□	M4	2 (280)	8 (0.315)	
PK566AW-N□	PK566BW-N□	M5	2.5 (350)	10 (0.394)	
PK564AW-N□	PK564BW-N□				
PK513PA-H□S	PK513PB-H□S	M2	0.25 (35)	5 (0.197)	
PK523HPA-H□S	PK523HPB-H□S	M3	1 (142)	6 (0.236)	
PK543AW-H□S	PK543BW-H□S	M4	2 (280)	8 (0.315)	
PK564AW-H□S	PK564BW-H□S	M5	2.5 (350)	10 (0.394)	

* □ in the motor model will contain a value representing the gear ratio.

5.3 Installing a load

When connecting a load to the motor, align the centers of the motor's output shaft and load shaft. Also, keep the overhang load and thrust load to the permissible values or below.

Note

- When coupling the load to the motor, pay attention to the centering of the shafts, belt tension, parallelism of the pulleys, and so on. Securely tighten the coupling and pulley set screws.
- Be careful not to damage the output shaft or bearings when installing a coupling or pulley to the motor's output shaft.
- Do not modify or machine the motor's output shaft. Doing so may damage the bearings and destroy the motor.
- When inserting a parallel key into the gear output shaft, do not apply excessive force by using a hammer or similar tool. Application of strong impact may damage the output shaft or bearings.

- **Using a coupling**

Align the centers of the motor's output shaft and load shaft in a straight line.

- **Using a belt drive**

Align the motor's output shaft and load shaft in parallel with each other, and position both pulleys so that the line connecting their centers is at a right angle to the shafts.

- **Using a gear drive**

Align the motor's output shaft and gear shaft in parallel with each other, and let the gears mesh at the center of the tooth widths.

- **Connecting with a key (Geared motor)**

With a geared motor, to connect a load to the gear output shaft having a key groove, first provide a key groove on the load and fix the load with the gear output shaft using the supplied key.

• **Installing on the flange surface (Harmonic geared type)**

With a harmonic geared type, a load can be installed directly to the gear using the load mounting holes provided on the flange surface.

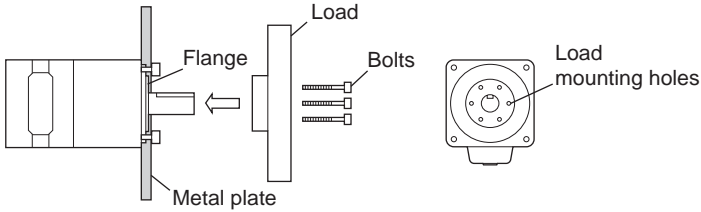

Motor model*	Bolt size	Number of bolts	Tightening torque [N·m (oz-in)]	Effective depth of thread [mm (in.)]
PK513-H□S	M2	3	0.35 (49)	3 (0.118)
PK523-H□S	M3	4	1.4 (198)	4 (0.157)
PK543-H□S	M3	6	1.4 (198)	5 (0.197)
PK564-H□S	M4	6	2.5 (350)	6 (0.236)

* □ in the motor model will contain a value representing the gear ratio.

Note

- When installing a load on the flange surface, the load cannot be affixed using the key groove (or flat surface) in the output shaft.
- Design an appropriate installation layout so that the load will not contact the metal plate or bolts used for installing the motor.

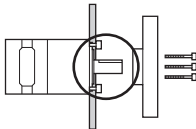

5.4 Permissible overhung load and permissible thrust load

The overhung load and the thrust load on the motor's output shaft must be kept under the permissible values listed on below.

Note

Failure due to fatigue may occur when the motor bearings and output shaft are subject to repeated loading by an overhung or thrust load that is in excess of the permissible limit.

Motor model		Permissible overhung load [N (lb.)]					Permissible thrust load [N (lb.)]
		Distance from the tip motor's output shaft [mm (in.)]					
Single shaft	Double shaft	0 (0)	5 (0.20)	10 (0.39)	15 (0.59)	20 (0.79)	
PK513PA	PK513PB	12 (2.7)	15 (3.3)	-	-	-	0.05 (0.11)*
PK523PA	PK523PB	25 (5.6)	34 (7.6)	52 (11.7)	-	-	0.11 (0.24)*
PK525PA	PK525PB						0.2 (0.44)*
PK523HPA	PK523HPB						0.11 (0.24)*
PK525HPA	PK525HPB						0.2 (0.44)*
PK523PMA	PK523PMB						0.11 (0.24)*
PK524PMA	PK524PMB						0.15 (0.33)*
PK525PMA	PK525PMB						0.2 (0.44)*
PK523HPMA	PK523HPMB						0.11 (0.24)*
PK524HPMA	PK524HPMB						0.15 (0.33)*
PK525HPMA	PK525HPMB						0.2 (0.44)*
PK544PA	PK544PB	20 (4.5)	25 (5.6)	34 (7.6)	52 (11.7)	-	0.3 (0.66)*
PK546PA	PK546PB						0.5 (1.1)*
PK544PMA	PK544PMB						0.3 (0.66)*
PK546PMA	PK546PMB						0.5 (1.1)*
PK543NAW	PK543NBW						0.21 (0.46)*
PK544NAW	PK544NBW						0.27 (0.59)*
PK545NAW	PK545NBW						0.35 (0.77)*
PK564PMA	PK564PMB	90 (20)	100 (22)	130 (29)	180 (40)	270 (60)	0.65 (1.43)*
PK566PMA	PK566PMB						0.87 (1.91)*
PK569PMA	PK569PMB						1.5 (3.3)*

- The figures indicated by * are the motor's mass [kg (lb.)]. The thrust load should not exceed the motor's mass.

Motor model		Permissible overhung load [N (lb.)]					Permissible thrust load [N (lb.)]
		Distance from the tip motor's output shaft [mm (in.)]					
Single shaft	Double shaft	0 (0)	5 (0.20)	10 (0.39)	15 (0.59)	20 (0.79)	
PK564NAW	PK564NBW	63 (14.1)	75 (16.8)	95 (21)	130 (29)	190 (42)	0.6 (1.32)*
PK566NAW	PK566NBW						0.8 (1.76)*
PK569NAW	PK569NBW						1.3 (2.9)*
PK566HNAW	PK566HNBW						0.8 (1.76)*
PK569HNAW	PK569HNBW						1.3 (2.9)*
PK523PA-T□	PK523PB-T□	15 (3.3)	17 (3.8)	20 (4.5)	23 (5.1)	-	10 (2.2)
PK543AW-T□	PK543BW-T□	10 (2.2)	14 (3.1)	20 (4.5)	30 (6.7)	-	15 (3.3)
PK564AW-T□	PK564BW-T□	70 (15.7)	80 (18)	100 (22)	120 (27)	150 (33)	40 (9)
PK545AW-P□	PK545BW-P□	73 (16.4)	84 (18.9)	100 (22)	123 (27)	-	50 (11.2)
PK543AW-P□	PK543BW-P□	109 (24)	127 (28)	150 (33)	184 (41)	-	50 (11.2)
PK566AW-P5	PK566BW-P5	200 (45)	220 (49)	250 (56)	280 (63)	320 (72)	100 (22)
PK566AW-P7.2	PK566BW-P7.2	250 (56)	270 (60)	300 (67)	340 (76)	390 (87)	100 (22)
PK566AW-P10	PK566BW-P10						
PK564AW-P□	PK564BW-P□	330 (74)	360 (81)	400 (90)	450 (101)	520 (117)	100 (22)
PK523PA-N□	PK523PB-N□	45 (10.1)	60 (13.5)	80 (18)	100 (22)	-	20 (4.5)
PK544AW-N□	PK544BW-N□	100 (22)	120 (27)	150 (33)	190 (42)	-	100 (22)
PK566AW-N5	PK566BW-N5	200 (45)	220 (49)	250 (56)	280 (63)	320 (72)	100 (22)
PK566AW-N7.2	PK566BW-N7.2	250 (56)	270 (60)	300 (67)	340 (76)	390 (87)	100 (22)
PK566AW-N10	PK566BW-N10						
PK564AW-N□	PK564BW-N□	330 (74)	360 (81)	400 (90)	450 (101)	520 (117)	100 (22)

- The figures indicated by * are the motor's mass [kg (lb.)]. The thrust load should not exceed the motor's mass.
- □ in the motor model will contain a value representing the gear ratio.

Motor model		Permissible overhung load [N (lb.)]					Permissible thrust load [N (lb.)]
		Distance from the tip motor's output shaft [mm (in.)]					
Single shaft	Double shaft	0 (0)	5 (0.20)	10 (0.39)	15 (0.59)	20 (0.79)	
PK513PA-H□S	PK513PB-H□S	50 (11.2)	75 (16.8)	-	-	-	60 (13.5)
PK523HPA-H□S	PK523HPB-H□S	110 (24)	135 (30)	175 (39)	250 (56)	-	140 (31)
PK543AW-H□S	PK543BW-H□S	180 (40)	220 (49)	270 (60)	360 (81)	510 (114)	220 (49)
PK564AW-H□S	PK564BW-H□S	320 (72)	370 (83)	440 (99)	550 (123)	720 (162)	450 (101)

- in the motor model will contain a value representing the gear ratio.

■ Permissible moment load of the harmonic geared type

When installing an arm or table on the flange surface, calculate the moment load using the formula below if the flange surface receives any eccentric load.

The moment load should not exceed the permissible value specified in the table.

Moment load: M [N·m (oz-in)] = $F \times L$

Motor model*	Permissible moment load [N·m (oz-in)]
PK513-H□S	0.7 (99)
PK523-H□S	2.9 (410)
PK543-H□S	5.6 (790)
PK564-H□S	11.6 (1640)

- * □ in the motor model will contain a value representing the gear ratio.

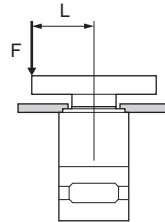

5.5 Installing the driver

When installing the driver in the device, mount it vertically or horizontally.

Installing the driver under conditions other than this could reduce its radiation effect.

Fix the driver directly to the metal enclosure using screws.

The items shown below are necessary in order to mount the driver. (The items are not included and must be provided by the customer.)

Torque the mounting screw to 0.5 N·m (71 oz-in).

Driver model	CRD5103PB CRD5107PB CRD5107HPB CRD5114PB	CRD5103P CRD5107P CRD5107HP CRD5114P	CRD5128PB
M3 screws	4 pcs. (2 pcs.)*	4 pcs.	2 pcs.
M3 spring washers	4 pcs. (2 pcs.)*	4 pcs.	2 pcs.
M3 nuts (Not necessary if screw holes are provided in the enclosure.)	4 pcs. (2 pcs.)*	4 pcs.	2 pcs.
Spacers [5 mm (0.20 in.) or more]	-	4 pcs.	-

* The figures in () apply when the mounting cutout B is used.

There must be a clearance of at least 25 mm (0.98 in.) and 50 mm (1.97 in.) in the horizontal and vertical directions, respectively, between the driver and enclosure or other equipment. When two or more drivers are to be installed side by side, provide 20 mm (0.79 in.) and 50 mm (1.97 in.) clearances in the horizontal and vertical directions, respectively.

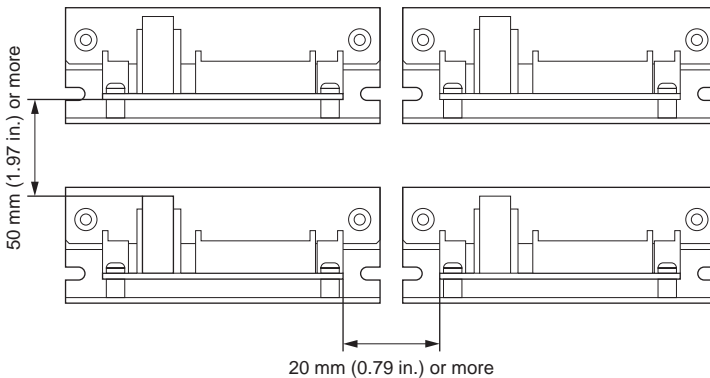

Note

- Install the driver in an enclosure.
- Do not install any equipment that generates a large amount of heat near the driver.
- Check ventilation if the ambient temperature of the driver exceeds 40 °C (104 °F).

- CRD5103PB, CRD5107PB, CRD5107HPB, CRD5114PB, CRD5128PB

Illustration shows CRD5103PB.

Horizontal installation

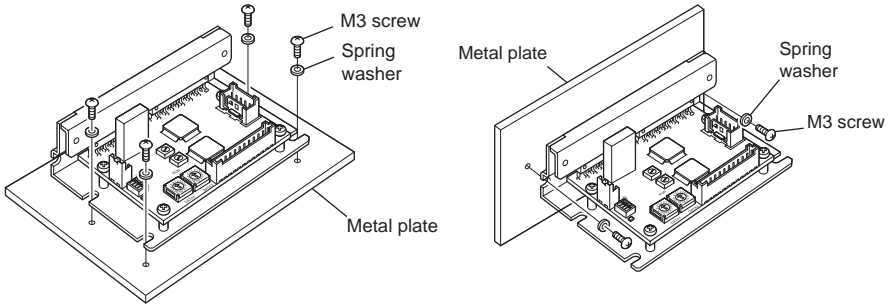

* For CRD5128, affix with screws (two locations).

Vertical installation

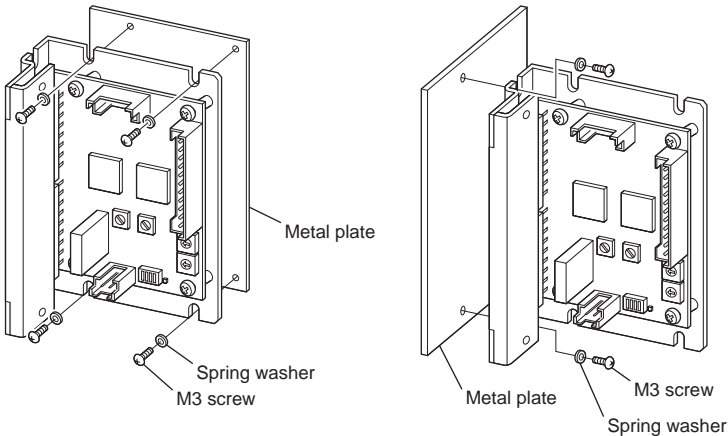

* For CRD5128, affix with screws (two locations).

Note

- Review the operating conditions if the surface temperature of the mounting plate exceeds 75 °C (167 °F).
- When installing CRD5103PB, CRD5107PB, CRD5107HPB and CRD5114PB, use either mounting cutout A or B. Do not use both simultaneously.
- When installing CRD5128PB, use either mounting holes or mounting cutouts.

- CRD5103P, CRD5107P, CRD5107HP, CRD5114P

Horizontal installation

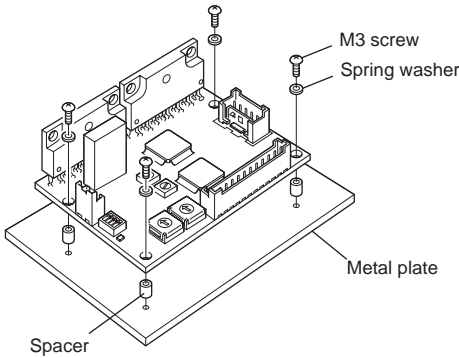

Vertical installation

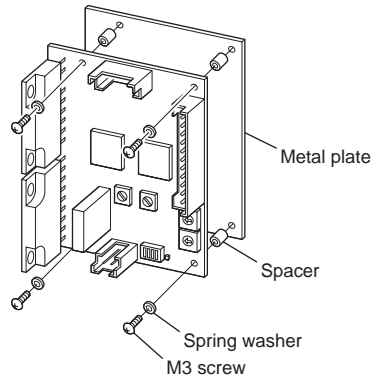

Note

- Do not use any holes on the MOSFET arrays to install the drivers.
- If the surface temperature of the driver's MOSFET array exceeds 90 °C (194 °F), review the operating conditions.
- The case containing the MOSFET arrays is insulated.

5.6 Installing and wiring in compliance with EMC Directive

Effective measures must be taken with regard to EMI (electromagnetic interference) caused by the **CRK** series motor and/or driver in the control system equipment operating nearby and EMS (electromagnetic susceptibility) of the **CRK** series motor and/or driver. Failure to do so may result in serious impairment of the machine's functionality. The use of the following installation and wiring methods will enable the **CRK** series motor and/or driver to be compliant with the EMC Directive.

Oriental Motor conducts EMC measurement of its **CRK** series motors and drivers in accordance with "Example of motor and driver installation and wiring" on p.31.

The user is responsible for ensuring the machine's compliance with the EMC Directive, based on the installation and wiring explained below.

Applicable Standards

EMI	Emission Tests	EN 61000-6-4
	Radiated Emission Test	EN 55011
EMS	Immunity Tests	EN 61000-6-2
	Radiation Field Immunity Test	IEC 61000-4-3
	Electrostatic Discharge Immunity Test	IEC 61000-4-2
	Fast Transient /Burst Immunity Test	IEC 61000-4-4
	Conductive Noise Immunity Test	IEC 61000-4-6

■ Power supply

The **CRK** series products are specifically designed for DC power supply input.

Use a DC power supply (such as a switching power supply) compliant with the EMC Directive.

■ Mains filter

Connect a mains filter on the input side of the DC power supply so as to prevent the noise generated in the driver from being transmitted externally via the power supply line.

When a power supply transformer is used, be sure to connect a mains filter on the AC input side of the power supply transformer. For mains filters, use 10ESK1 (Tyco Electronics CORCOM), ZAG2210-11S (TDK Corporation), or an equivalent.

- Install the mains filter as close to the AC input terminal of DC power supply as possible. Also, secure the I/O cables (AWG18: 0.75 mm² or more) using cable clamps or the like so that the cables won't lift from the surface of the enclosure panel.
- The cable used to ground the mains filter must be as thick and short to the grounding point as possible.
- Do not wire the AC input cable (AWG18: 0.75 mm² or more) and the output cable of the mains filter (AWG18: 0.75 mm² or more) in parallel. If these two cables are wired in parallel, noise inside the enclosure will be connected to the power supply cable via stray capacitance, reducing the effect of the mains filter.

■ Grounding method

When grounding the driver and mains filter, use a cable of the largest possible size and connect to the ground point over the shortest distance so that no potential difference will be generated at the grounded position. The ground point must be a large, thick and uniform conductive surface.

Install the motor onto a grounded metal surface.

■ Wiring the power supply cable and I/O signals cable

- Use a shielded cable of AWG22 (0.3 mm^2) or more in diameter for the driver power supply cable. Use a shielded cable of AWG20 (0.5 mm^2) or more in diameter for CRD5128PB.
- Use a shielded cable of AWG24 (0.2 mm^2) or more in diameter for the driver I/O signals cable, and keep it as short as possible.
- Use a metal cable clamp that contacts the shielded cable along its entire circumference to secure/ground the power supply cable or I/O signals cable. Attach a cable clamp as close to the end of the cable as possible, and connect it as shown in the figure.

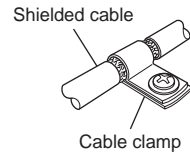

■ Notes about installation and wiring

- Connect the motor, driver and any surrounding control system equipment directly to the grounding point so as to prevent a potential difference from generating between grounds.
- When relays or electromagnetic switches are used together with the system, use mains filters and CR circuits to suppress surges generated by them.
- Keep the cable lengths as short as possible. Do not wind or bundle extra lengths.
- Separate the power supply cables such as motor cable and power supply cable from the signal cables, and wire them apart by around 100 to 200 mm (3.94 to 7.87 in.). If a power supply cable must cross over a signal cable, wire them at right angles. Keep an appropriate distance between the AC input cable and output cable of the mains filter.

■ Example of motor and driver installation and wiring

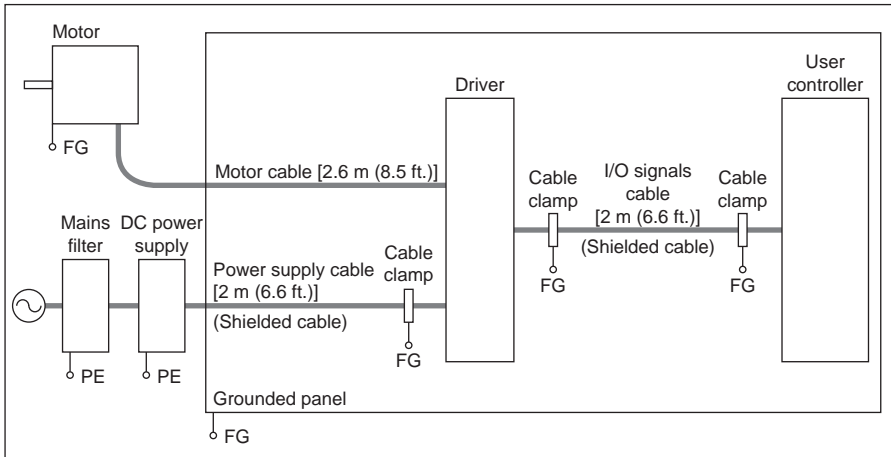

■ Precautions about static electricity

Static electricity may cause the driver to malfunction or suffer damage. Be careful when handling the driver with the power on. Always use an insulated screwdriver when adjusting the motor current using the control on the driver.

Note

Do not come close to or touch the driver while the power is on.

6 Connection

This section covers the methods of connecting the driver, motor, power supply and controller, as well as the connection examples and I/O signals.

The motors of the high-resolution types, high-torque types and geared types (**CRK513P**, **CRK523P**) use a motor leads connector connection system. Use the supplied connector leads. Optional connector leads and driver cable sets (sold separately) are also available. See p.53 for details.

6.1 Connection example

■ NPN type

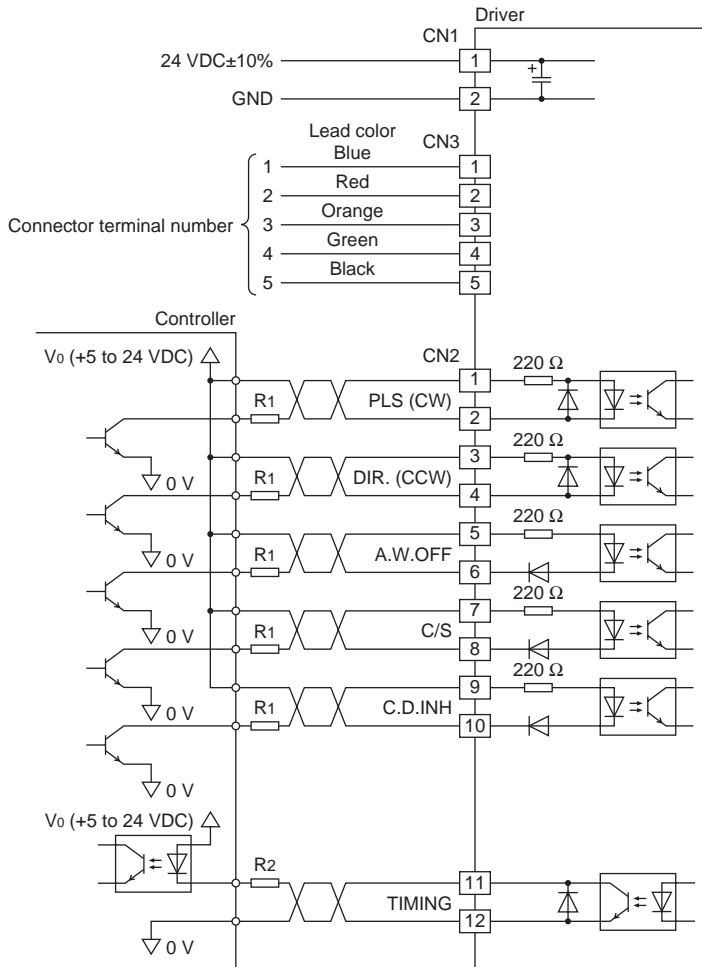

■ PNP type

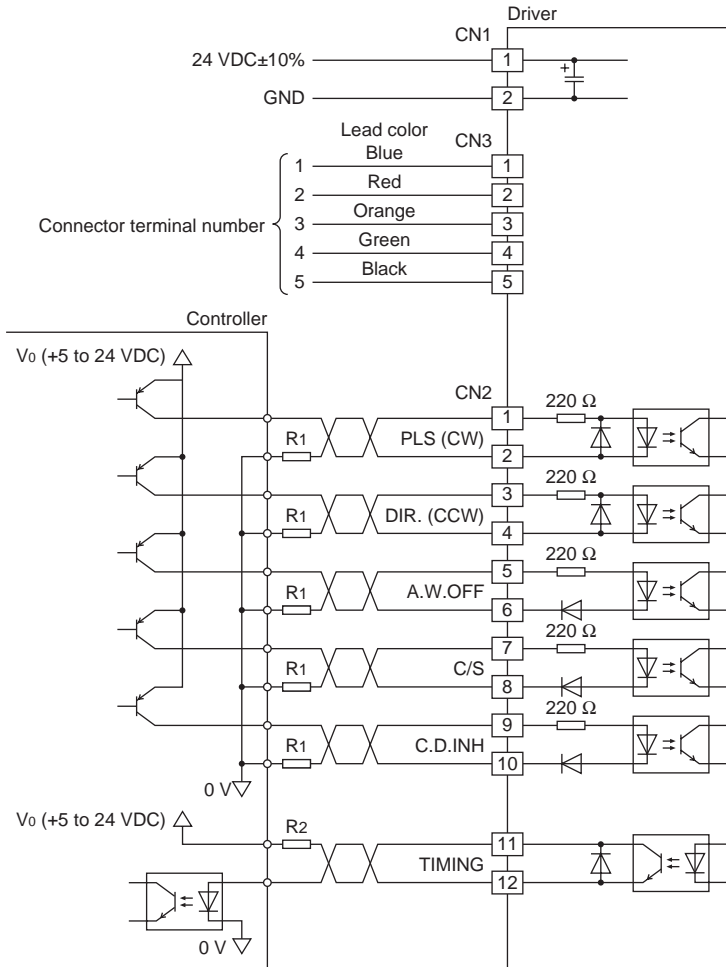

Note

- Use 5 VDC as input signal voltage. If the input signal voltage exceeds 5 VDC, connect an appropriate external resistance R1 in order to keep the input current to 10 to 20 mA.
Example) When V₀ is 24 VDC R1: 1.5 to 2.2 kΩ, 0.5 W or more.
- Use the output signal voltage between 5 VDC and 24 VDC, 10 mA or less. When it is above 10 VDC, connect R2 to keep the current below 10 mA or less.
- Be certain the I/O signals cable that connects the driver and controller is as short as possible. The maximum input frequency will decrease as the cable length increases.

■ Connector pin assignments for driver

Connector No.	Pin No.	Type	Signal	Description
CN1	1	Input	POWER +	+24 VDC
	2	Input		POWER -
CN2	1	Input	PLS (CW) +	Pulse input (CW pulse)*
	2	Input		
	3	Input	DIR. (CCW) +	Rotation direction input (CCW pulse)*
	4	Input		
	5	Input	A.W.OFF +	All windings off input
	6	Input		
	7	Input	C/S +	Step angle select input
	8	Input		
	9	Input	C.D.INH +	Current cutback release input
	10	Input		
	11	Output	TIMING +	Excitation timing output
	12	Output		
CN3	1	Output	MOTOR	Blue motor lead
	2	Output		Red motor lead
	3	Output		Orange motor lead
	4	Output		Green motor lead
	5	Output		Black motor lead

* When this switch is set to 1-pulse input mode, the inputs are the pulse input (PLS) and the rotation direction input (DIR.).

When this switch is set to 2-pulse input mode, the inputs are CW pulse input (CW) and CCW pulse input (CCW).

■ Connector pin assignments for connector-type motor

Terminal No.	1	2	3	4	5
Motor leads color	Blue	Red	Orange	Green	Black

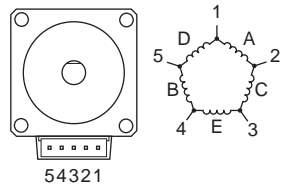

6.2 Applicable contacts and connector housings

Connect the driver, using the following suitable contacts and connector housings. When crimping contacts for connectors, be sure to use the crimping tool specified by the connector maker. Optional motor cables and driver cable sets (sold separately) are also available. See p.53 for details.

■ Connector housing, contact and crimping tool for driver (Molex)

Driver model		CRD5103PB, CRD5107PB, CRD5107HPB, CRD5114PB, CRD5103P, CRD5107P, CRD5107HP, CRD5114P	CRD5128PB
For power supply (CN1)	Connector housings	51103-0200	51067-0200
	Contacts	50351-8100	50217-9101
	Specified crimping tool	57295-5000	57189-5000
For I/O signals (CN2)	Connector housings	51103-1200	51103-1200
	Contacts	50351-8100	50351-8100
	Specified crimping tool	57295-5000	57295-5000
For motor (CN3)	Connector housings	51103-0500	51067-0500
	Contacts	50351-8100	50217-9101
	Specified crimping tool	57295-5000	57189-5000

- For the power supply cable, use a cable of AWG22 (0.3 mm²). Keep the wiring distance as short as possible [less than 2 m (6.6 ft.)] to suppress the effect of noise. For CRD5128PB, use a cable of AWG20 (0.5 mm²).
- For the I/O signals cable, use a cable of AWG24 to 22 (0.2 to 0.3 mm²) and keep the wiring distance as short as possible [less than 2 m (6.6 ft.)] to suppress the effect of noise.

Note

- When connecting the cable, be careful regarding the polarity of the power supply. Incorrect power supply polarity could damage the drivers.
- Have the connector plugged in securely. Insecure connection may cause malfunction or damage to the motor or driver.
- When pulling out a connector, pull it out by slightly expanding the latch part of the connectors using a precision screwdriver.
- Always wait at least 5 sec. after switching off the power supply before switching it back on again or connecting/disconnecting the motor cables connector.
- Separate I/O signals cable at least 100 mm (3.94 in.) from electromagnetic relays and other than inductance loads. Additionally, route I/O signals cable perpendicular to power supply cables and motor cables, rather than in a parallel fashion.
- Do not route the power supply cables in the same conduits as other power supply lines and motor cables.
- If the motor cable or power supply cable generates an undesirable amount of noise after wiring/installation, shield the cable or install a ferrite core.

■ Connector housing, contact and crimping tool for motor (Molex)

Motor type	PK513P PK52□P, PK52□HP PK52□PM, PK52□HPM	PK54□P PK54□PM	PK56□PM
Connector housings	51065-0500	51103-0500	51144-0500
Contacts	50212-8100	50351-8100	50539-8100
Specified crimping tool	57176-5000	57295-5000	57189-5000

Note

- When connecting a connector-type motor, affix the cable at the connection part to prevent the connection part from receiving stress due to the flexing of the cable. Make the cable's radius of curvature as large as possible.
- When disconnecting the connector-type motor cable, pull the connector horizontally along the output shaft to remove. The motor may be damaged if force is applied in any other direction.
- The connector leads that come with the **CRK54□P**, **CRK54□PM** and **CRK56□PM** have a connector with a lock mechanism. When removing this type of cable, release the connector lock first. Forcibly pulling out the cable without releasing the connector lock may damage the motor and connector.

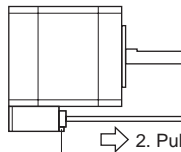

1. Release the lock.
(**CRK54□P**, **CRK54□PM** and **CRK56□PM** only)
2. Pull out the cable horizontally.

6.3 Connecting the power supply

Use a power supply that can supply the following current capacity.

Driver model	CRD5103PB CRD5103P	CRD5107PB CRD5107HPB CRD5107P CRD5107HP	CRD5114PB CRD5114P	CRD5128PB
Power supply input voltage	24 VDC \pm 10%			
Power supply current capacity	0.7 A or more	1.4 A or more	2.5 A or more	4.3 A or more

6.4 Explanation of I/O signals

■ Input signals

The signal states indicate the state of the internal photocoupler (ON: power conducted; OFF: power not conducted).

- Example of connection with a current sink output circuit

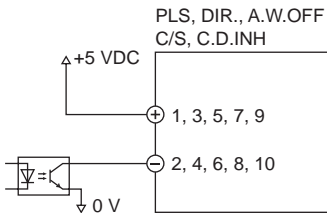

- Example of connection with a current source output circuit

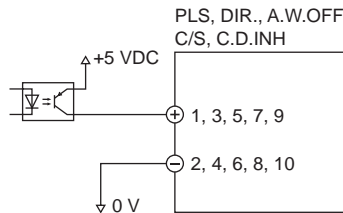

- PLS (CW) input and DIR. (CCW) input

This driver can select either 1-pulse input mode or 2-pulse input mode as the pulse input mode to match the controller used. For details on how to set the pulse input mode, see 7.2 “Pulse input modes” on p.44.

1-pulse input mode

The controller pulses are connected to the PLS+ input (pin No.1) and the PLS- input (pin No.2), and the rotation direction is connected to the DIR.+ input (pin No.3) and DIR.- input (pin No.4).

- When the DIR. input is ON, a fall of the pulse input from ON to OFF will rotate the motor one step in the CW direction.
- When the DIR. input is OFF, a fall of the pulse input from ON to OFF will rotate the motor one step in the CCW direction.

Use an input pulse signal with a waveform having a sharp rise and fall, as shown in the figure.

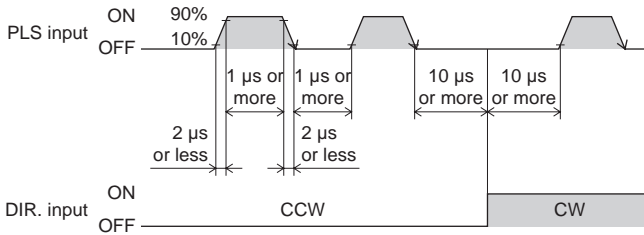

Note The interval for switching the motor direction represents the response time of the circuit. Set this interval to an appropriate time after which the motor will respond.

2-pulse input mode

The controller's CW pulses are connected to the CW+ (pin No.1) and the CW- (pin No.2), while the CCW pulses are connected to the CCW+ (pin No.3) and the CCW- (pin No.4).

- When the CW pulse input changes from the ON state to OFF state, the motor will rotate one step in the CW direction.
- When the CCW pulse input changes from the ON state to OFF state, the motor will rotate one step in the CCW direction.

Use an input pulse signal with a waveform having a sharp rise and fall, as shown in the figure.

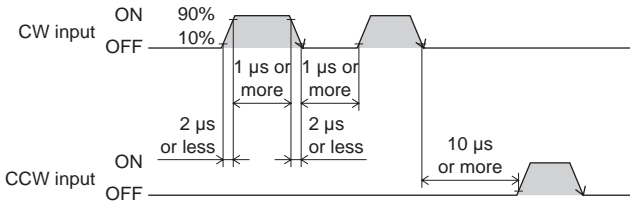

- Note**
- The interval for switching the motor direction represents the response time of the circuit. Set this interval to an appropriate time after which the motor will respond.
 - Always set the photocoupler to OFF when not inputting pulse signals.
 - Do not input CW input and CCW input at the same time. If one of these pulses is input when the other is ON the motor will not run properly.

- **A.W.OFF (All windings off) input**

Use this signal only when the motor's shaft must be rotated mechanically for the purpose of position adjustment.

- When the A.W.OFF input is turned ON, the driver stops supplying current to the motor and the motor's holding torque is lost.
- When the A.W.OFF input is turned OFF, the current supply to the motor resumes, thereby restoring the motor's holding torque.

- **C/S (step angle switching) input**

This signal selects the step angle set with one of the two step angle setting switches (DATA1 and DATA2).

For example, when DATA1 is set to [0: 0.72°] and DATA2 is set to [6: 0.072°], this signal can switch between 0.72°/step operation and 0.072°/step operation. For details on step angle setting switch, see 7.1 “Step angle” on p.42

- When the C/S input is turned to ON, operation switches to the setting for step angle setting switch DATA2.
- When the C/S input is turned to OFF, operation switches to the setting for step angle setting switch DATA1.

Note

- With the C/S input, the status of selection is read when the power to the driver is turned on.
- Do not switch the C/S input while the motor is operating, or the motor may misstep and stop or cause an offset in position.
- If the C/S input must be used to switch the step angles after the driver power has been turned on, do so while the driver's TIMING output is ON and the motor is at rest. Switching the C/S input under any other condition may disable the TIMING output.

■ Output signals

The driver's output signals are photocoupler/open-collector outputs. The signal states indicate the state of the internal photocoupler (ON: power conducted; OFF: power not conducted).

- Example of connection with a current source output circuit

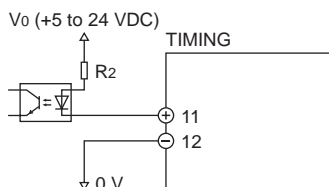

- Example of connection with a current sink output circuit

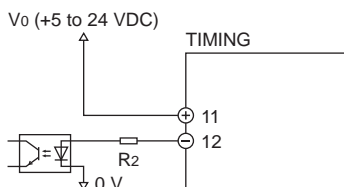

• TIMING (excitation timing) output

When the motor excitation state (combined phases of current flowing) is the excitation home position (step 0), the driver switches on the timing output. The motor excitation state is reset to the excitation home position when the power supply is switched on.

When the motor has a base step angle of $0.72^\circ/\text{step}$, the TIMING output turns ON with a rotation of every 7.2° from the excitation home position in synchronization with a pulse input. The TIMING output behaves differently depending on the combined motor and number of divisions.

Motor type	Number of divisions		TIMING output
	Number of divisions 1	Number of divisions 10	
Motor with $0.72^\circ/\text{step}$ base step angle	0.72°	0.072°	Every 7.2°
Motor with $0.36^\circ/\text{step}$ base step angle	0.36°	0.036°	Every 3.6°
Geared motor with 7.2:1 gear ratio	0.1°	0.01°	Every 1°

Also, when detecting the mechanical home position for a mechanical device, by making an AND circuit for the mechanical home position sensor and the TIMING output, the variation in the motor stop position within the mechanical home position sensor can be reduced and the mechanical home position made more precise.

Note

- When using the TIMING output, stop the motor's output shaft at an integer multiple of 7.2° .
- When switching the step angle using the C/S input, do this with the motor stopped and the timing output on. If the C/S input is switched in any other condition, the timing output may not turn ON even after the motor has rotated 0.72° .

6.5 Timing chart

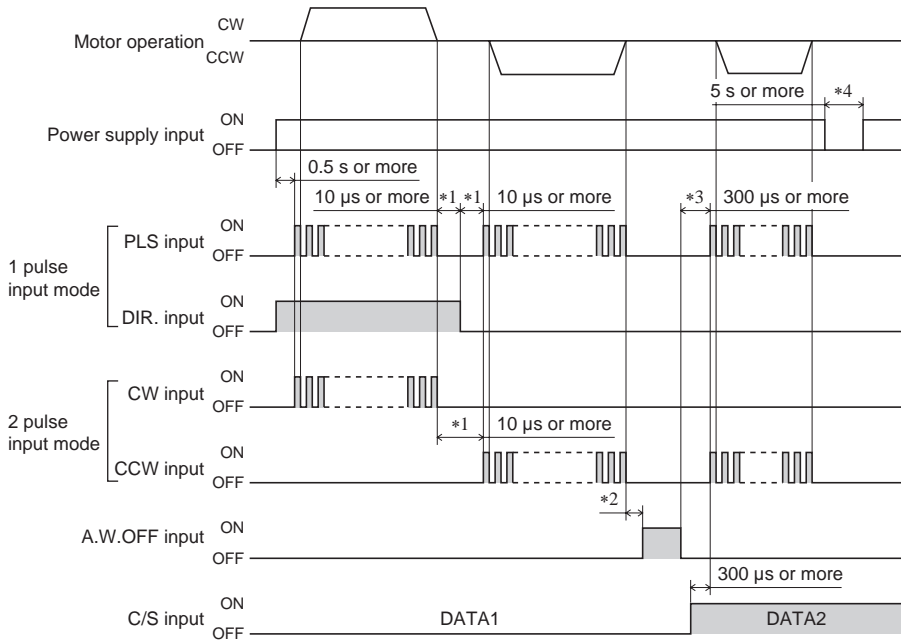

The  section indicates that the photocoupler diode is emitting light.

- *1 “10 μs or more” indicated in connection with the DIR. input select time (1-pulse input mode) or CW/CCW input select time (2-pulse input mode) indicates a circuit response time. Set it to the time required for the motor to respond to the applicable pulse input.
- *2 The specific duration varies depending on the load inertial moment, load torque, self-starting frequency, etc.
- *3 Do not input pulse signals immediately after switching the A.W.OFF input to OFF, given that it will affect the motor’s starting characteristics.
- *4 After turning off the power supply, wait at least 5 sec. before turning the power supply back on.

7 Setting

7.1 Step angle

When setting the motor's step angle, use the resolution select switch and the step angle setting switches [DATA1] [DATA2].

Resolution select switch

Factory setting R1

Step angle setting switches

Factory setting DATA1: 0

DATA2: 0

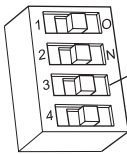

Resolution select switch (R1/R2)

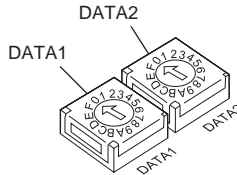

The table below lists the step angles that can be set.

Resolution select switch: R1				Resolution select switch: R2			
DATA1 or DATA2	Number of divisions	Resolution	Step angle	DATA1 or DATA2	Number of divisions	Resolution	Step angle
0	1	500	0.72°	0	× 2.5	200	1.8°
1	2	1000	0.36°	1	× 1.25	400	0.9°
2	2.5	1250	0.288°	2	1.6	800	0.45°
3	4	2000	0.18°	3	2	1000	0.36°
4	5	2500	0.144°	4	3.2	1600	0.225°
5	8	4000	0.09°	5	4	2000	0.18°
6	10	5000	0.072°	6	6.4	3200	0.1125°
7	20	10000	0.036°	7	10	5000	0.072°
8	25	12500	0.0288°	8	12.8	6400	0.05625°
9	40	20000	0.018°	9	20	10000	0.036°
A	50	25000	0.0144°	A	25.6	12800	0.028125°
B	80	40000	0.009°	B	40	20000	0.018°
C	100	50000	0.0072°	C	50	25000	0.0144°
D	125	62500	0.00576°	D	51.2	25600	0.0140625°
E	200	100,000	0.0036°	E	100	50000	0.0072°
F	250	125,000	0.00288°	F	102.4	51200	0.00703125°

Note

- Step angles are theoretical values.
- With the high-resolution type, the base step angle is set to 0.36° and the resolution to 1000.
- If you are using a geared type, the actual step angle is calculated by dividing the step angle by the gear ratio.

■ How to set step angle

1. Set the resolution select switch to “R1” or “R2”.
R1: Among the step angles shown in the table on the previous page, those corresponding to the resolution select switch setting of “R1” can be used.
R2: Among the step angles shown in the table on the previous page, those corresponding to the resolution select switch setting of “R2” can be used.
2. Set a desired step angle using the step angle setting switches.
You can set different step angles using DATA1 and DATA2.
3. Using the C/S input, select whether to use the step angle corresponding to DATA1 or DATA2 to operate the motor.

Setting example: When switching the step angle between $0.72^\circ/\text{step}$ and $0.09^\circ/\text{step}$

1. Set the resolution select switch to “R1”.
2. Set the step angle setting switch [DATA1] to “0” and [DATA2] to “5”.
3. To operate the motor at $0.72^\circ/\text{step}$, turn the C/S input OFF.
To operate the motor at $0.09^\circ/\text{step}$, turn the C/S input ON.

Note

- The step angles corresponding to the resolution select switch settings of R1 and R2 cannot be set simultaneously.
- Do not switch the C/S input or the step angle setting switch while the motor is operating, or the motor may misstep and stall.

7.2 Pulse input modes

Either the 1-pulse or 2-pulse input mode may be selected in accordance with the controller used.

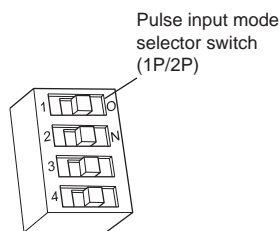

- When the motor is to be controlled through the pulse signal and the rotation direction signal that specifies the motor's direction of rotation, set the to "1P".
- When the motor is to be controlled through 2-pulse signal input via the CW pulse signal and CCW pulse signal, set to "2P".

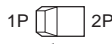

Note

The factory setting of the pulse input mode depends on the destination country. Check the pulse input mode setting in accordance with the pulse mode in the controller used.

7.3 Smooth drive function

The smooth drive function achieves low vibration, low noise operation even in full step mode (0.72°). With this function, each full step is automatically divided into 16 microsteps. This provides extremely smooth operation. This function makes it not necessary to change the pulse signals (speed, pulse count) from the controller.

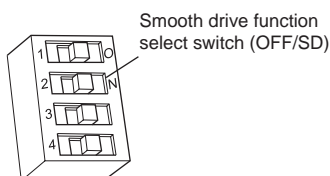

Factory setting SD (smooth drive enable)

The smooth drive function can be used only when the step angle is set to [DATA: 0] though [DATA: 6] for [R1] or [DATA: 0] through [DATA: 7] for [R2]. (The [DATA] value indicates the [DATA1] or [DATA2] setting of the step angle setting switch on p.42.)

- When the smooth drive function is used, set to "SD".



- When the smooth drive function is not used, set to "OFF".



Note

The smooth drive function does not work if the step angle is set to a division number greater than 10 (0.072°)*. The [SD] setting is ignored. (The same effect as "OFF".)

* High-resolution type: 0.036°

7.4 Motor current

When the load is light and there is a margin for motor torque, the motor's operating vibration and the temperature increase of the motor and driver can be held down by lowering the motor's operating current and standstill current.

Factory setting RUN: Motor rated current
 STOP: About 50% of motor's rated current

■ Connection of current setting DC ammeter

Connect the DC ammeter to the blue motor lead wire and pin No.1 of the driver's CN3 in series.

Do not connect the red motor leads and pin No.2 or black motor leads and pin No.5.

■ Setting the motor operating current

1. Connect a DC ammeter between the motor and driver.
2. Turn the C.D.INH input to ON. Do not apply other input signals.
3. Turn on the driver's power supply (24 VDC).

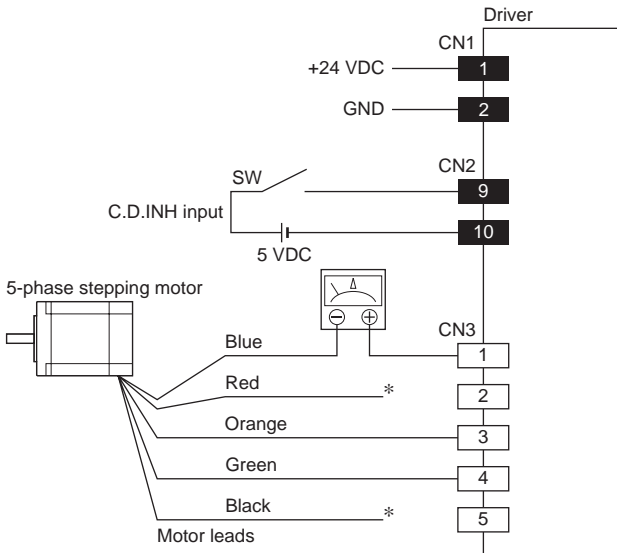

Note

If the red or black motor lead (indicated by *) contacts the other lead, equipment, etc., damage may result. Provide an insulation measure to protect against electric shock.

4. Turn the motor operating current potentiometer (RUN) with a precision screwdriver, set the motor operating current.
 When the potentiometer is turned counterclock wise, the current decreases.

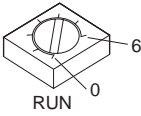

The scale values are not displayed on the control.

CRD5103PB, CRD5103P
 (Representative values)

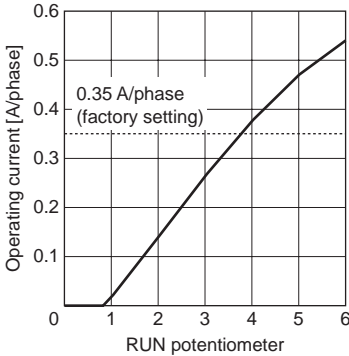

CRD5107PB, CRD5107HPB
 CRD5107P, CRD5107HP
 (Representative values)

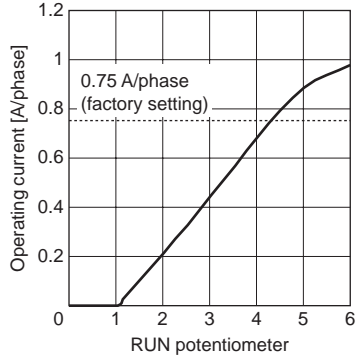

CRD5114PB, CRD5114P
 (Representative values)

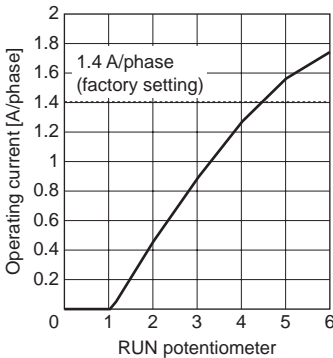

CRD5128PB
 (Representative values)

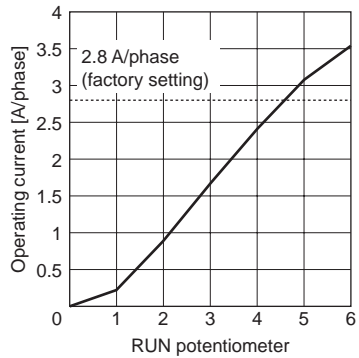

Current corresponding to a dual-phase value flows to the ammeter. A value of one-half that which is indicated equals the single-phase current value.

Example:

- When the indication value on the ammeter shows 1.5 A, it stands for the setting of 0.75 A/phase.
- When the indication value on the ammeter shows 0.7 A, it stands for the setting of 0.35 A/phase.

5. Turn the C.D.INH input to OFF.

6. Continue setting the current while the motor is at a standstill.

■ Setting current at motor standstill

The current at motor standstill is factory set so that it will be about 50% of the motor's operating current (This proportion does not change, even if the motor's operating current is changed).

1. After setting the motor operating current, turn the C.D.INH input to OFF and then input the power supply to the driver.
2. Turn the motor stop current potentiometer (STOP) with a precision screwdriver, setting the current at motor standstill.

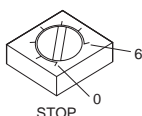

The scale values are not displayed on the control.

CRD5103PB, CRD5103P
(Representative values)

CRD5107PB, CRD5107HPB
CRD5107P, CRD5107HP
(Representative values)

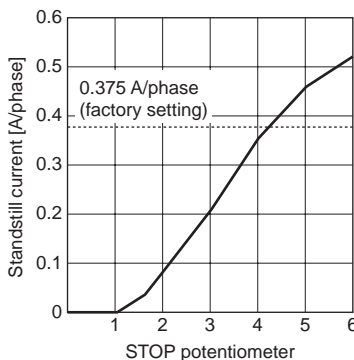
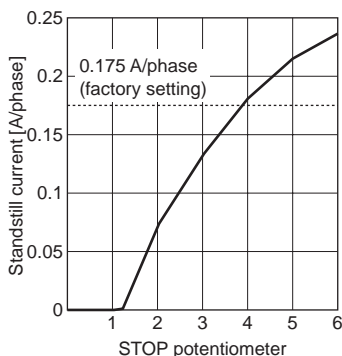

CRD5114PB, CRD5114P
(Representative values)

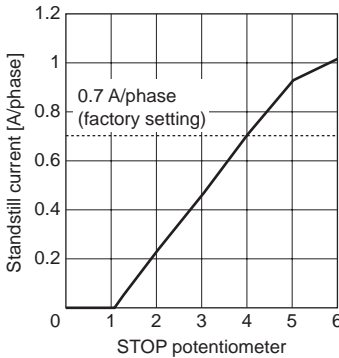

CRD5128PB
(Representative values)

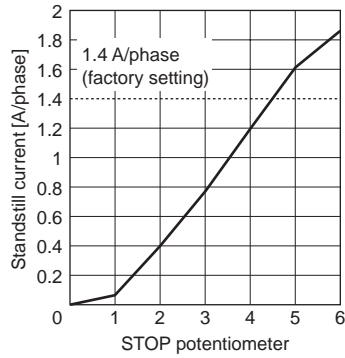

- When the setting is complete, turn off the power supply. After about 0.1 sec. has passed since the pulse was stopped, the motor's operating current automatically decreases to the set value of current at motor standstill.

Note

- Set the motor's operating current to a value not exceeding the rated current of the motor.
- If the motor current potentiometer is used to adjust current, set the potentiometer graduation to 2 or more. If the potentiometer is set too low, current will become zero and the motor will lose its holding brake torque.
- A range of adjustment of the current at motor standstill is within one-half the set value of motor operating current. When the current at motor standstill is decreased too much, motor starting or maintenance of the location may be hindered. Do not reduce it any more than is necessary.
- When setting the current at motor standstill, be sure to do so after setting the motor's operating current and turning off the power supply to the driver.

8 Inspection

It is recommended that periodic inspections be conducted for the items listed below after each operation of the motor.

If an abnormal condition is noted, stop the use and contact your nearest office.

Inspection items

- Are the motor installation screws loose?
- Are there any abnormal sounds from the motor's bearing section (ball bearings) or elsewhere?
- Do any of the motor leads have damage or stress, or is there any play at the section for connection with the driver?
- Is there any deviation between the centers of the motor's output shaft and load shaft?
- Are the driver installation screws or connector sections loose?
- Is there any dust or dirt on the driver?
- Are there any strange smells or other abnormalities at the driver?

Note

The driver uses semiconductor elements. Handle the driver carefully. There is a danger of the driver being damaged by static electricity, etc.

9 Troubleshooting and remedial actions

During motor operation, the motor or driver may fail to function properly due to an improper speed setting or wiring. When the motor cannot be operated correctly, refer to the contents provided in this section and take appropriate action. If the problem persists, contact your nearest office.

Phenomenon	Possible cause	Remedial action
<ul style="list-style-type: none"> The motor is not energized. The motor's output shaft can be turned easily by hand. 	Connection error in the motor leads or power supply cable.	Check the connections between the driver, motor and power supply.
	Current potentiometer incorrectly set. If the setting is too low, the motor torque will also be too low and operation will be unstable.	Return the current potentiometer to its factory setting and check.
	The A.W.OFF input is set to ON.	Switch the A.W.OFF input to OFF and confirm that the motor is excited.
The motor does not run.	Pulse input line connection error.	<ul style="list-style-type: none"> Check the controller and driver connections. Check the pulse signal specifications (voltage and width).
	The CW input and the CCW input came ON at the same time.	Input either the CW input or the CCW input, and always switch the other terminal to OFF.
The motor rotates in the direction opposite that which is specified.	The CW input and the CCW input are connected in reverse.	Connect the CW pulses to the CW input (pin No. 1 and 2), and CCW pulses to the CCW input (pin No. 3 and 4).
Motor operation is unstable.	Error in the motor's cable connection.	Check the driver and motor connections.
	Current potentiometer incorrectly set. If the setting is too low, the motor torque will also be too low and operation will be unstable.	Return the current potentiometer to its factory setting and check.
	Pulse input line connection error.	<ul style="list-style-type: none"> Check the controller and driver connections. Check the pulse signal specifications (voltage and width).

Phenomenon	Possible cause	Remedial action
Motor operating time is longer than the specified time (self-start operation).	Effect of the smooth drive function.	Disable the smooth drive function and check the operation.
Loss of synchronization during acceleration or running	The centers of the motor' output shaft and load shaft are not aligned.	Check the connection condition of the motor output shaft and load shaft.
	The load or load fluctuation is too high.	Check for large load fluctuations during motor operation. If adjusting the operating pulse speed to low and high torque eliminates the problem, it is necessary to review the load conditions.
	The starting pulse speed is too high.	Lower the starting pulse speed and set it again to a speed at which stable starting is possible.
	The acceleration (deceleration) time is too short.	Lengthen the acceleration (deceleration) time in order to reset it to a time at which stable starting is possible.
	Electrical noise.	Check running with only the motor, driver and required controller. If the impact of noise is recognized, take countermeasures, such as rewiring for greater distance from the noise source, changing the signal cables to shielded wire, or mounting a ferrite core.
Motor does not move the set amount.	Mistake in switching C/S input.	Check the C/S input switching state.
	Wrong step angle settings.	Check the settings of the step angle setting switches [DATA1] and [DATA2].
	Pulse output count is too low or too high.	Check whether or not the number of pulses required for operation at the set step angle are being output.
Current does not drop when the motor stops.	The C.D.INH input is set to ON.	Switch the C.D.INH input to OFF.
	The pulse input remains ON even after pulses have stopped.	After the pulses stop, always switch to OFF.

9 Troubleshooting and remedial actions

Phenomenon	Possible cause	Remedial action
Motor vibration too great.	The centers of the motor's output shaft and load shaft are not aligned.	Check the connection condition of the motor output shaft and load shaft.
	Motor resonating.	If the vibration decreases when the operating pulse speed is changed, it means the motor is resonating. Change the operating pulse speed setting. Or install a clean damper (sold separately) to suppress vibration.
	Load too small.	Lower the motor operating current. Vibration will increase if the motor's output torque is too large for the load.
Motor too hot.	Long continuous operation time of the motor.	Decrease the operation time of the motor per session or increase the standstill time. Make sure that the motor case temperature will not exceed 100 °C (212 °F).
	The C.D.INH input is set to ON.	Switch the C.D.INH input to OFF.
	Motor standstill current adjustment too high.	Adjust the motor's standstill current to 50% of the operating current or below.
Driver too hot.	Long continuous operation time of the motor.	Decrease the operation time of the motor per session or increase the standstill time. Make sure the surface temperature of the MOSFET array does not exceed 90°C (194 °F) while the motor is in operation. If the driver is installed with a mounting plate, the surface temperature of the mounting plate should not exceed 75 °C (167 °F).
TIMING output not output.	C/S input switched when TIMING output is ON.	Switch the C/S input when TIMING output is ON.

10 Options (sold separately)

■ Connector leads

The lead wires come preassembled with a crimped connector for easy connection of a connector-type motor. [Unit models come standard with a 0.6 m (2 ft.) connector leads.]

Model	Length	Conductor	Applicable product
LC5N06A	0.6 m (2 ft.)	AWG24 (0.2 mm ²)	PK513P, PK523P, PK525P, PK523HP, PK525HP, PK523PM, PK524PM, PK525PM, PK523HPM, PK524HPM, PK525HPM, PK523P-T□, PK523P-N□, PK513P-H□S, PK523HP-H□S
LC5N10A	1 m (3.3 ft.)		
LC5N06B	0.6 m (2 ft.)	AWG22 (0.3 mm ²)	PK544P, PK546P, PK544PM, PK546PM
LC5N10B	1 m (3.3 ft.)		
LC5N06C	0.6 m (2 ft.)		PK564PM, PK566PM, PK569PM
LC5N10C	1 m (3.3 ft.)		

■ Driver cable set

A set of lead wires (for power supply, I/O signals and motor connection; one each), preassembled with a crimped connector matching the driver-side connector.

Model	Length	Conductor	Applicable product
LC504SD5	0.6 m (2 ft.)	AWG22(0.3 mm ²)	CRD5103PB, CRD5107PB CRD5107HPB, CRD5114PB CRD5103P, CRD5107P CRD5107HP, CRD5114P
LC505SD5		For I/O signals: AWG22 (0.3 mm ²) For power supply and motor: AWG20 (0.5 mm ²)	CRD5128PB

■ Motor connector set (Molex)

A set of connector housings and contacts matching a connector-type motor.

Each bag contains enough housings and contacts for connecting 30 motors.

Model	Applicable motor	Connector housings	Contacts	Applicable cable
CS5N30A	PK513P PK523P PK525P PK523HP PK525HP PK523PM PK524PM PK525PM PK523HPM PK524HPM PK525HPM PK523P-T□ PK523P-N□ PK513P-H□S PK523HP-H□S	51065-0500	50212-8100	AWG30 to 24* (0.05 to 0.2 mm ²) Outer diameter of sheathed cable: Ø1.4 mm (Ø0.06 in.) or less. Stripped length: 1.3 to 1.8 mm (0.05 to 0.07 in.)
CS5N30B	PK544P PK546P PK544PM PK546PM	51103-0500	50351-8100	AWG28 to 22* (0.08 to 0.3 mm ²) Outer diameter of sheathed cable: Ø1.15 to 1.8 mm (Ø0.05 to 0.07 in.) Stripped length: 2.3 to 2.8 mm (0.09 to 0.11 in.)
CS5N30C	PK564PM PK566PM PK569PM	51144-0500	50539-8100	AWG24 to 18* (0.2 to 0.75 mm ²) Outer diameter of sheathed cable: Ø1.4 to 3 mm (Ø0.06 to 0.12 in.) Stripped length: 3 to 3.5 mm (0.12 to 0.14 in.)

* The driver's motor connector (CN3) accepts cables of AWG24 to 22 (0.2 to 0.3 mm²) in size.

- Unauthorized reproduction or copying of all or part of this manual is prohibited. If a new copy is required to replace an original manual that has been damaged or lost, please contact your nearest Oriental Motor branch or sales office.
- Oriental Motor shall not be liable whatsoever for any problems relating to industrial property rights arising from use of any information, circuit, equipment or device provided or referenced in this manual.
- Characteristics, specifications and dimensions are subject to change without notice.
- While we make every effort to offer accurate information in the manual, we welcome your input. Should you find unclear descriptions, errors or omissions, please contact the nearest office.
- **Orientalmotor** is a registered trademark or trademark of Oriental Motor Co., Ltd., in Japan and other countries.
Other product names and company names mentioned in this manual may be registered trademarks or trademarks of their respective companies and are hereby acknowledged. The third-party products mentioned in this manual are recommended products, and references to their names shall not be construed as any form of performance guarantee. Oriental Motor is not liable whatsoever for the performance of these third-party products.

© Copyright ORIENTAL MOTOR CO., LTD. 2008

- Please contact your nearest Oriental Motor office for further information.

ORIENTAL MOTOR U.S.A. CORP.
 Technical Support Tel:(800)468-3982
 8:30 A.M. to 5:00 P.M., P.S.T. (M-F)
 7:30 A.M. to 5:00 P.M., C.S.T. (M-F)
 E-mail: techsupport@orientalmotor.com
 www.orientalmotor.com

ORIENTAL MOTOR (EUROPA) GmbH
 Headquarters and Düsseldorf Office
 Tel:0211-52067-00 Fax:0211-52067-099
 Munich Office
 Tel:089-3181225-00 Fax:089-3181225-25
 Hamburg Office
 Tel:040-76910443 Fax:040-76910445

ORIENTAL MOTOR (UK) LTD.
 Tel:01256-347090 Fax:01256-347099

ORIENTAL MOTOR (FRANCE) SARL
 Tel:01 47 86 97 50 Fax:01 47 82 45 16

ORIENTAL MOTOR ITALIA s.r.l.
 Tel:02-93906346 Fax:02-93906348

TAIWAN ORIENTAL MOTOR CO.,LTD.
 Tel:(02)8228-0707 Fax:(02)8228-0708

SINGAPORE ORIENTAL MOTOR PTE LTD
 Tel:(6745)7344 Fax:(6745)9405

ORIENTAL MOTOR (MALAYSIA) SDN. BHD.
 Tel:(03)22875778 Fax:(03)22875528

ORIENTAL MOTOR (THAILAND) CO.,LTD.
 Tel:66-2-254-6113 Fax:66-2-254-6114

INA ORIENTAL MOTOR CO.,LTD.
 KOREA
 Tel:(032)822-2042~3 Fax:(032)819-8745

ORIENTAL MOTOR CO.,LTD.
 Headquarters Tokyo, Japan
 Tel:(03)3835-0684 Fax:(03)3835-1890