

Gather and Use Information for Effective Preventive Maintenance

Get more useful data for preventive maintenance when you build cost-effective parallel information systems for control and maintenance using Omron's smart remote I/O terminals. These remote I/O terminals include economical expansion units that let you design a monitoring system for maintenance information.

Smart Measuring and Smart Counting

These two functions take advantage of the intelligent capabilities of DeviceNet. In Smart Measuring, the remote I/O terminals convert machine operating time and operational changes to data enabling monitoring without increasing the load between controllers. Smart Counting keeps track of the ON/OFF operations and total operating time so preventive maintenance can be scheduled based on service life estimates. The operation counter and operating time monitor functions cannot be used simultaneously.

What Device is Reporting Problems?

These slave units can hold comments such as device number, type and location to shorten troubleshooting by identifying fault locations and faulty devices. They can also be used to monitor network communication errors.

- 16-point input and output terminals, NPN or PNP models with DeviceNet connection
- Expansion terminals available in 8-point and 16-point units
- Input filter function eliminates noise from contact bounce and, using OFF response time, can capture pulses shorter than the communications time
- Sensor inrush current protection delays accepting input for 100 ms after input power turns on
- Inputs powered by the network power supply
- Compact size saves space in control panels
- Network Power Monitor function

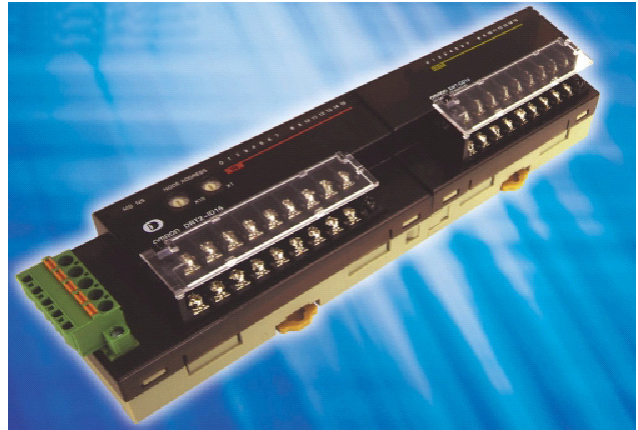

Features and Functions

Omron's DRT2-series Smart Slaves do not just input and output ON/OFF signals. They collect a variety of value-added information to help increase the rate of operation without changing the wiring for existing DeviceNet networks. In particular, they allow the sepa-

ration of control systems and maintenance systems so that maintenance systems can be created independently of control systems.

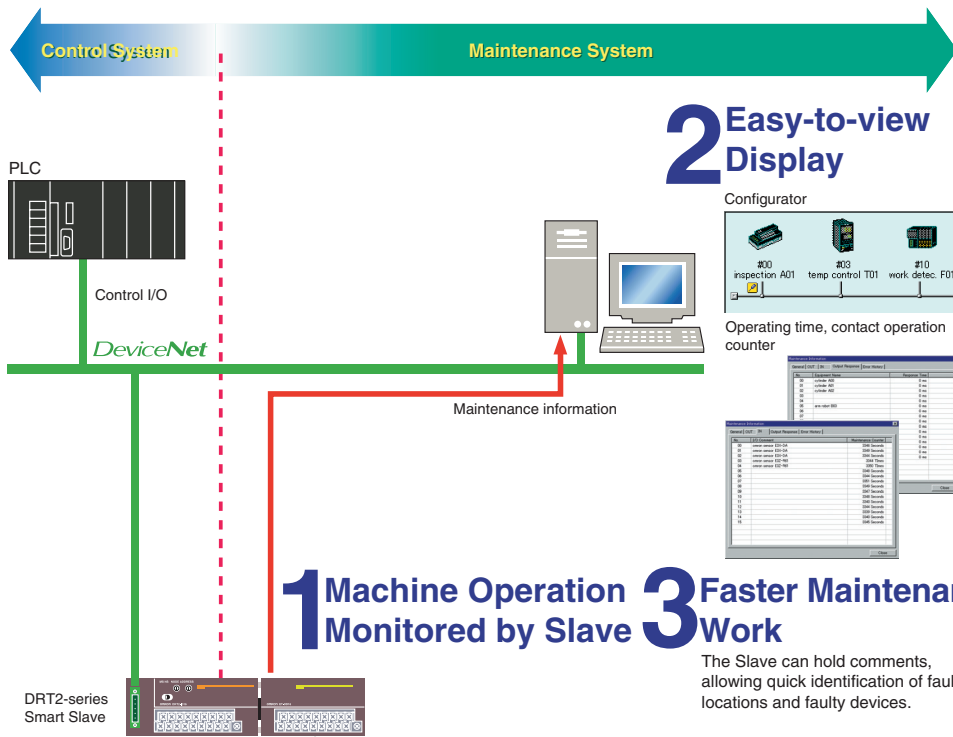

2 Easy-to-view Display

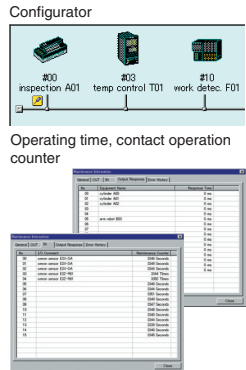

1 Machine Operation Monitored by Slave 3 Faster Maintenance Work

The Slave can hold comments, allowing quick identification of fault locations and faulty devices.

Smart Measuring

The Slave Unit represents machine operating time and operational changes as data, enabling monitoring without increasing the load between controllers.

Smart Counting

By counting the number of ON/OFF operations and the total operating time, the Slave Unit can provide notification when maintenance is required.

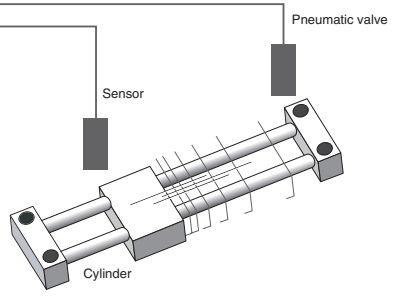

All data can be converted to electronic format and, by combining with an OMRON PLC (CS/CJ Series), checked directly from Ethernet or the Internet to allow remote maintenance.

Information monitoring for each Slave

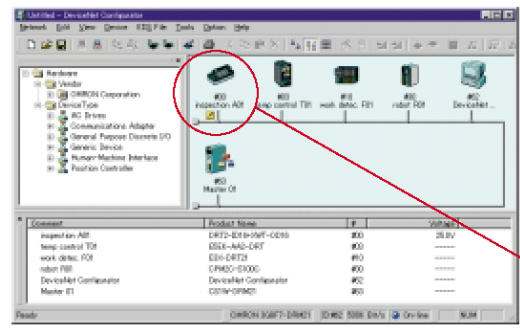
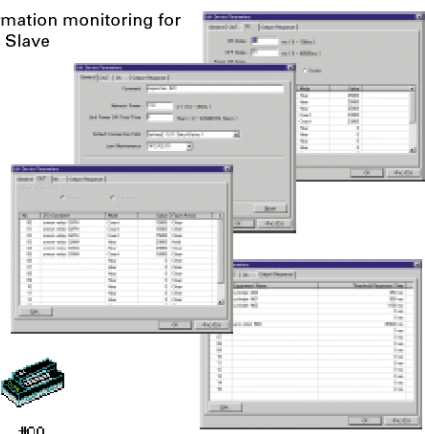

Configurator's maintenance mode screen
The Configurator's screen images may be changed without notice.

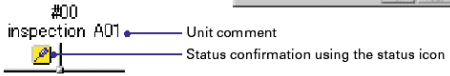

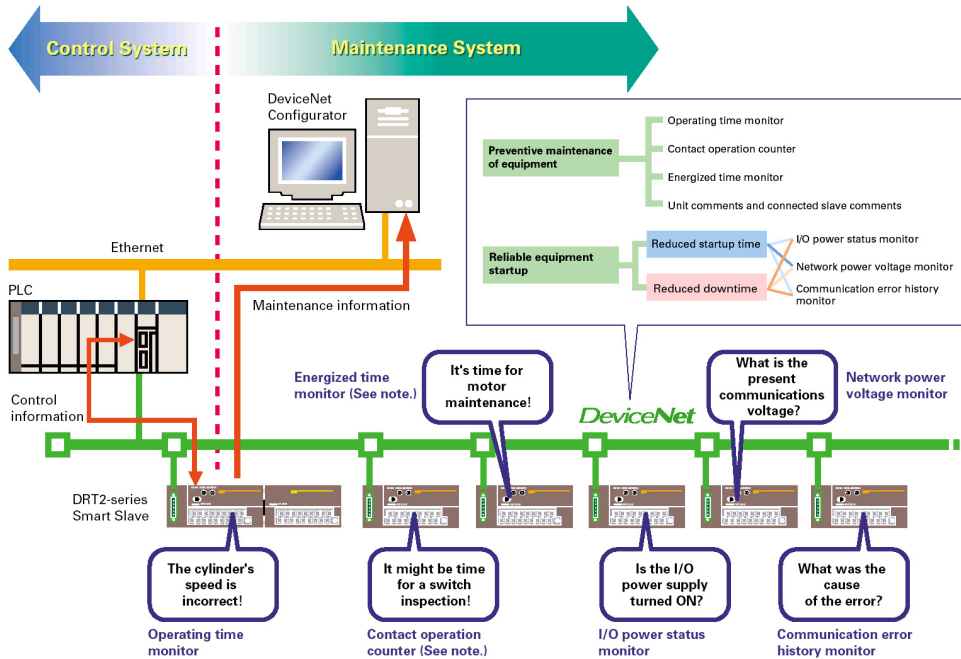

Note: The contact operation counter function and the energized time monitor function cannot be used simultaneously.

■ Operating Time Monitor Function

Errors in machine operation can be detected by measuring the time interval between output and input.

The Slave can perform high-speed measurement of the interval between the time an output is turned ON by a specified bit and the time an input is turned ON. It is possible to read this measurement result (between 2 and 65,535 ms) using the Configurator or explicit message communications. This feature contributes to preventive maintenance by allowing the detection of mechanical deterioration, such as air leaks in cylinders. A threshold value can also be set in the Slave so that a flag turns ON when the time becomes longer than a set time.

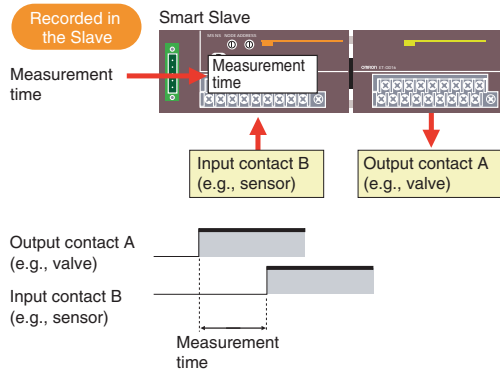

Note: This function can only be used when combinations of Basic Units and Expansion Units that have both inputs and outputs are used.

■ Contact Operation Counter Function

Provides notification of maintenance timing for I/O devices, such as switches and actuators.

This function provides notification of maintenance timing for input and output devices, such as switches and actuators.

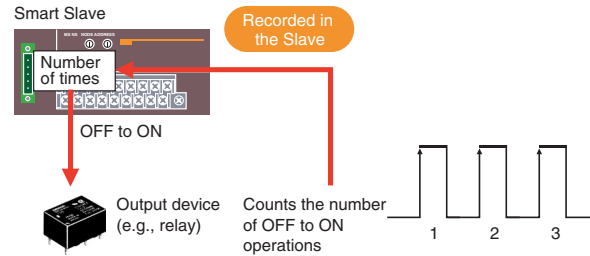

■ Energized Time Monitor Function

Every six minutes the Slave records the total energized time of, for example, a motor. This record can be read using the Configurator or explicit message communications.

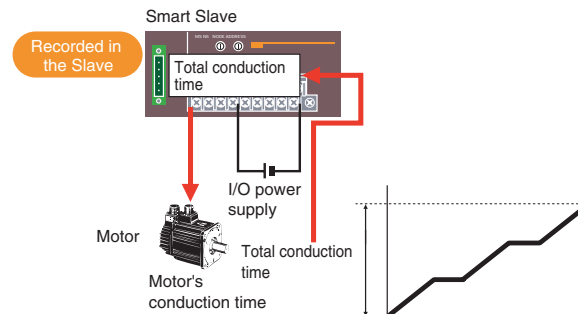

Note: The contact operation counter function and the unit conduction time monitor function cannot be used simultaneously.

A threshold value can be set in the Slave so that a flag turns ON when this value is exceeded. (This is possible with both the contact operation counter function and the energized time monitor function.) This makes it possible to identify when parts approach the end of their service life, and provides useful data for preventive maintenance.

■ Unit Comment/Connected Slaves Function

Identification of fault locations and confirmation of replacement parts can be performed quickly.

Unit Command Function

Setting the location in the Slave's internal comments means that the Slave can be detected from the Configurator.

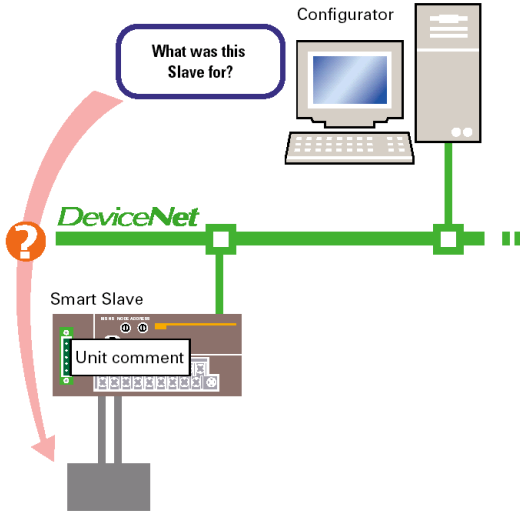

Configurator's maintenance mode screen

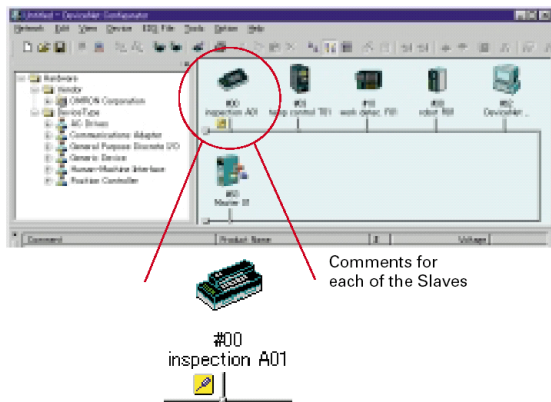

Connected Devices Comment Function

By setting the maker name and model number for each contact (e.g., sensors and valves), comments can be set for each of the input and output contacts in the Slaves.

Configurator screen

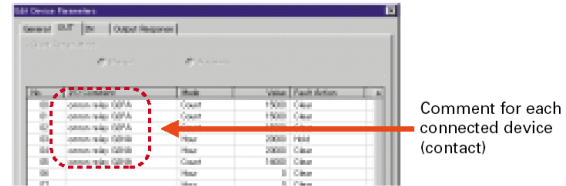

Confirmation and preparation of replacement parts when failures occur can be performed quickly.

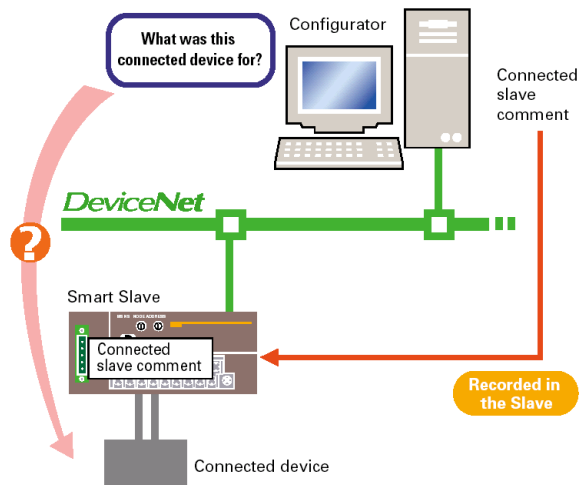

All of this data can be handled as electronic data and can therefore be used, for example, to create electronic manuals or databases of maintenance parts.

■ Network Startup

Networks can be started up simply by making rotary switch settings and connecting network cables.

Easy Node Address Setting

Node addresses are set with easy-to-use rotary switches.

Node address setting using rotary switches

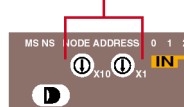

Automatic Baud Rate Recognition Function

The automatic baud rate recognition function eliminates the need for DIP switches.

No Wiring Required for Unit's Internal Circuit Power Supply

Power for the Unit's internal circuits is obtained from the network power and so no wiring is required for the Unit's internal circuit power supply.

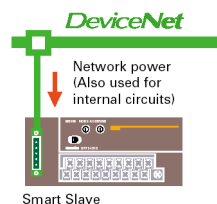

■ Network Power Voltage Monitor Function

The network power voltage status and the I/O power status can be understood at a glance via the network.

The network power voltage is recorded in the Slave (network power voltage monitor function). It is also possible to detect whether the I/O power supply is turned ON, and to output a warning if it is not (I/O power status monitor function). This means that the status of the network power voltage and I/O power supply for each SmartSlave can be confirmed at a glance from the Configurator, contributing to reductions in startup time.

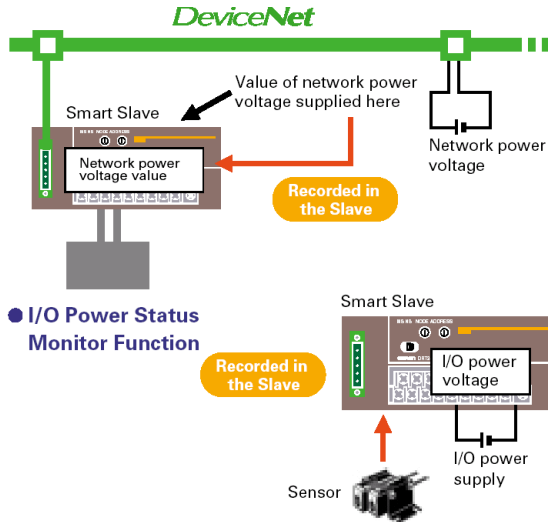

■ Communication Error History Monitor Function

Causes for communications errors can be monitored.

Information (i.e., communication error code and network power voltage at the time) for four previous errors can be recorded in the Slave. This error history can be read from Smart Slaves that are removed from the network when correcting an error, enabling more effective maintenance.

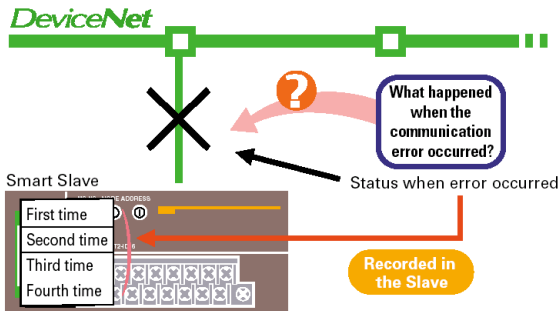

■ Improved Structural Flexibility Smallest in Its Class

The width of the Basic Unit is 115 mm (77% of 150-mm DRT1-series models) and the width of the Expansion Unit is 94 mm, giving a total expanded width of 209 mm, making it the smallest device of its class in the industry.

Easy Mounting and Dismounting of Terminal Blocks

Terminal blocks can be mounted and dismantled with ease.

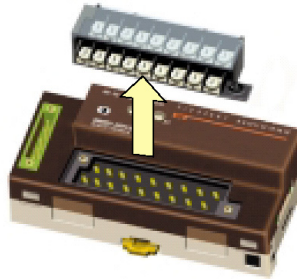

Easy Expansion with Expansion Units

The Smart Slaves can be expanded easily by freely combining Expansion Units with Basic Units using snap-on mounting. This means less wiring work is required.

Clamp-type Communications Connectors

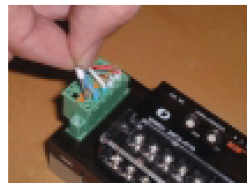

Wiring can be performed by inserting post terminals.



The connector allows easy checking using a tester.

Input Filter Function

The influence of noise can be removed using the ON response time. Also, very small pulses that are shorter than the communication time can be handled using the OFF response time.

Function for Handling Sensor Inrush Current

In order to prevent incorrect input due to inrush current when, for example, power to a sensor is turned ON, the Slave can be set not to accept input for 100 ms after input supply is turned ON.

Specifications

■ General Specifications

Item	Specification
Network power voltage	11 to 25 VDC (supplied from the communications connector)
I/O power supply voltage	20.4 to 26.4 VDC (24 VDC -15% to +10%)
Noise immunity	Conforms to IEC61000-4-4: 2 kV (power lines)
Vibration resistance	10 to 50 Hz, 0.7-mm double amplitude
Shock resistance	200 m/S ²
Dielectric strength	500 VAC (between isolated circuits)
Insulation resistance	20 MΩ min. (between isolated circuits)
Ambient operating temperature	-10 to +55°C
Ambient operating humidity	35% to 85%
Ambient atmosphere	No corrosive gases
Ambient storage temperature	-20 to +65°C
Mounting method	35-mm DIN track mounting
Mounting strength	50 N (in directions other than the DIN track direction), 10 N (in the DIN track direction)
Screw tightening torque	M3 (power supply, I/O terminals): 0.3 to 0.5 N•m

■ Input Specifications

Item	Specification
Model number	DRT2-ID16 DRT2-ID16-1
Internal I/O common processing	NPN PNP
Number of I/O points	16 inputs
ON voltage	15 VDC min. (between each input terminal and V) 15 VDC min. (between each input terminal and G)
OFF voltage	5 VDC min. (between each input terminal and V) 5 VDC min. (between each input terminal and G)
OFF current	1.0 mA max. per point (at 24 VDC)
Input current	6.0 mA max. per point at 24 VDC; 3.0 mA max. per point at 17 VDC
ON delay time	1.5 ms max.
OFF delay time	1.5 ms max.
Number of points per common	16 points per common

■ Output Specifications

Item	Specification
Model number	DRT2-OD16 DRT2-OD16-1
Internal I/O common processing	NPN PNP
Number of I/O points	16 outputs
Rated output current	0.5 A per point, 4.0 A per common
Residual voltage	1.2 V max. (0.5 A between each output terminal and G) 1.2 V max. (0.5 A between each output terminal and V)
Leakage current	0.1 mA max.
ON delay time	0.5 ms max.
OFF delay time	1.5 ms max.
Number of points per common	16 points per common

Installation

Internal Circuit Diagrams

Remote I/O Terminals (Models with 16 Transistor Inputs)
DRT2-ID16 (NPN)/DRT2-ID16-1 (PNP)

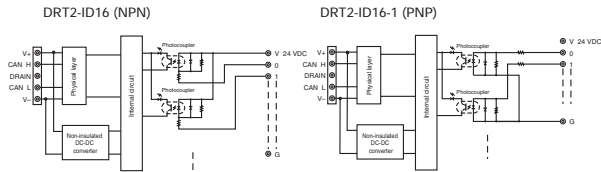

Remote I/O Terminals (Models with 16 Transistor Outputs)
DRT2-OD16 (NPN)/DRT2-OD16-1 (PNP)

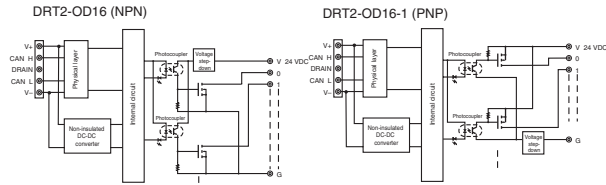

Remote I/O Terminals Expansion Units (Models with 8 Transistor Inputs)
XWT-ID08 (NPN)/ID08-1 (PNP)

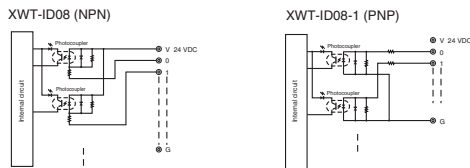

Remote I/O Terminals Expansion Units (Models with 8 Transistor Outputs)
XWT-OD08 (NPN)/OD08-1 (PNP)

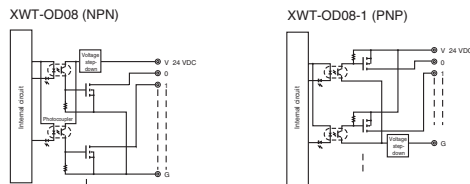

Remote I/O Terminal Expansion Units (Models with 16 Transistor Inputs)
XWT-ID16 (NPN)/ID16-1 (PNP)

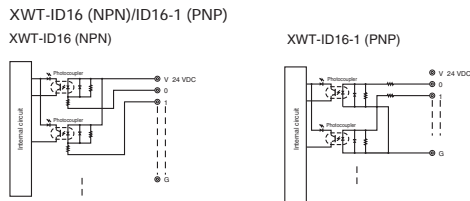

Remote I/O Terminal Expansion Units (Models with 16 Transistor Outputs)
XWT-OD16 (NPN)/OD16-1 (PNP)

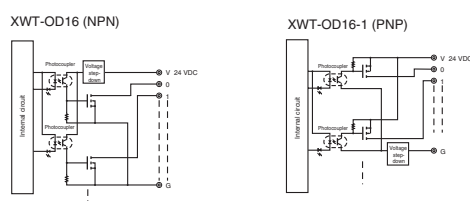

Wiring Diagrams

Remote I/O Terminals (Models with 16 Transistor Inputs)
DRT2-ID16 (NPN)/DRT2-ID16-1 (PNP)

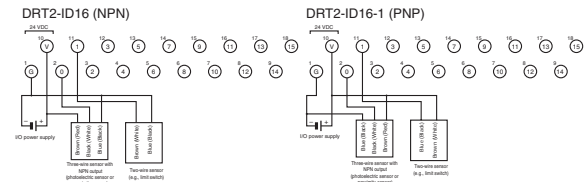

Remote I/O Terminals (Models with 16 Transistor Outputs)
DRT2-ID16 (NPN)/DRT2-OD16-1 (PNP)

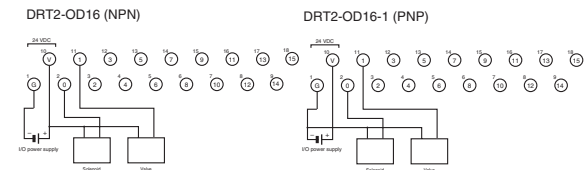

Remote I/O Terminal Expansion Units (Models with 8 Transistor Inputs)
XWT-ID08 (NPN)/ID08 (PNP)

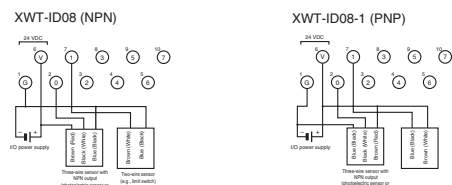

Remote I/O Terminal Expansion Units (Models with 8 Transistor Outputs)
XWT-OD08 (NPN)/OD08-1 (PNP)

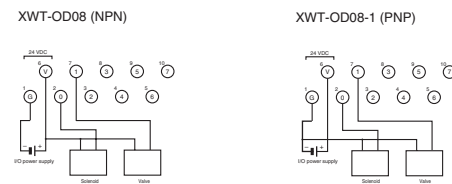

Remote I/O Terminal Expansion Units (Models with 16 Transistor Inputs)
XWT-ID16 (NPN)/ID16-1 (PNP)

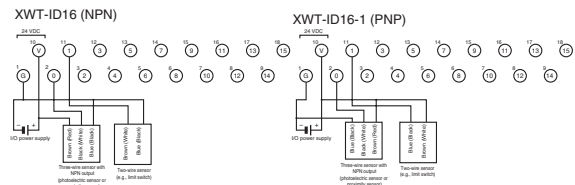

Remote I/O Terminal Expansion Units (Models with 16 Transistor Outputs)
XWT-OD16 (NPN)/OD16-1 (PNP)

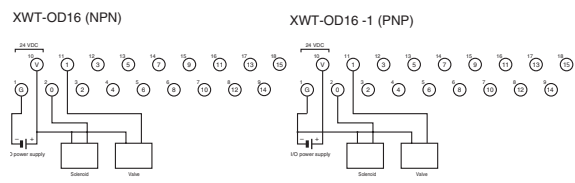

Dimensions (mm)

Remote I/O Terminal Basic Units

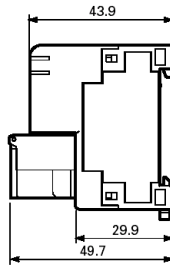
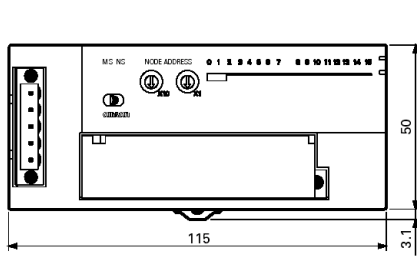

Model number
DRT2-ID16 -1
DRT2-ID16
DRT2-OD16 -1
DRT2-OD16

Remote I/O Terminal Expansion Units

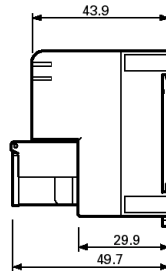
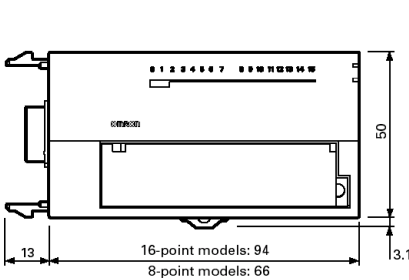

Model number
XWT-ID16 -1
XWT-ID16
XWT-OD16 -1
XWT-OD16
XWT-ID08 -1
XWT-ID08
XWT-OD08 -1
XWT-OD08

Ordering Information

Remote I/O Terminal Basic Units

Specification	Part number
16 inputs, NPN	DRT2-ID16
16 inputs, PNP	DRT2-ID16-1
16 outputs, NPN	DRT2-OD16
16 outputs, PNP	DRT2-OD16-1

Remote I/O Terminal Expansion Units

Specification	Part number
8 expansion inputs, NPN	XWT-ID08
8 expansion inputs, PNP	XWT-ID08-1
8 expansion outputs, NPN	XWT-OD08
8 expansion outputs, PNP	XWT-OD08-1
16 expansion inputs, NPN	XWT-ID16
16 expansion inputs, PNP	XWT-ID16-1
16 expansion outputs, NPN	XWT-OD16
16 expansion outputs, PNP	XWT-OD16-1

ALL DIMENSIONS SHOWN ARE IN MILLIMETERS. To convert millimeters into inches, divide by 25.4



OMRON ELECTRONICS LLC
 One East Commerce Drive
 Schaumburg, IL 60173
1-800-55-OMRON

OMRON ON-LINE
 Global - <http://www.omron.com>
 USA - <http://www.omron.com/oei>
 Canada - <http://www.omron.com/oci>

OMRON CANADA, INC.
 885 Milner Avenue
 Toronto, Ontario M1B 5V8
416-286-6465