

G5-Series AC Servo Drives with General-purpose Pulse Train or Analog Inputs

R88D-KT



Contents

- Ordering Information
- Specifications
 - General Specifications
 - Characteristics
 - Servo Drives with Single-phase 100 VAC Input Power
 - Servo Drives with Single-phase or three-phase 200 VAC Input Power
 - Servo Drives with Three-phase 200 VAC Input Power
 - Servo Drives with 400 VAC Input Power
- Names and Functions
 - Servo Drive Part Names
 - Functions
- Dimensions



Ordering Information

Refer to the Ordering Information.

Specifications

General Specifications

Item		Specifications	
Ambient operating temperature and humidity		0 to 55°C, 85% max. (with no condensation)	
Storage ambient temperature and humidity		-20 to 65°C, 85% max. (with no condensation)	
Operating and storage atmosphere		No corrosive gases	
Vibration resistance		10 to 60 Hz and at an acceleration of 5.88 m/s ² or less (Not to be run continuously at the resonance point)	
Insulation resistance		Between power supply terminal/power terminal and FG terminal: 0.5 MΩ min. (at 500 VDC Megger)	
Dielectric strength		Between power supply/power line terminals and FG terminal: 1,500 VAC for 1 min at 50/60 Hz	
Protective structure		Built into panel	
International standard	EC directives	EMC directive	EN55011, EN61000-6-2, IEC61800-3
		Low voltage command	EN61800-5-1
		Machinery directives	EN954-1 (Cat.3), EN ISO 13849-1: 2008 (PLC,d), ISO 13849-1: 2006 (PLC,d), EN61508 (SIL2), EN62061 (SIL2), EN61800-5-2 (STO), IEC61326-3-1 (SIL2)
	UL standards		UL508C *
	CSA standards		CSA C22.2 No.14
	Korean Radio Regulations (KC)		Certified

* The Servo drive of R88D-KT20□ and smaller capacity the one are UL-Listed.

The Servo drive of R88D-KT30□ and bigger capacity the one are UL-Recognized.

Note: 1. The above items reflect individual evaluation testing. The results may differ under compound conditions.

Note: 2. Always disconnect all connections to the Servo Drive before you perform insulation resistance tests on it. If you perform an insulation resistance test while the Servo Drive is connected, the Servo Drive may be damaged. Never perform dielectric strength tests on the Servo Drive. Failure to follow this precaution may result in damaging internal elements.

Note: 3. Some Servo Drive parts will require maintenance. For details, refer to the G5 series USER'S MANUAL. Confirm the Manual No. that is listed in Related Manuals.

Note: 4. To conform EMC directive, the tips on wiring and installation written in the G5 series user's manual must be followed. Confirm the Manual No. that is listed in Related Manuals.

G5-Series
System Configuration

EtherCAT Communications
AC Servo Drive

EtherCAT Communications
Linear Motor Type
AC Servo Drive

General-purpose Inputs
AC Servo Drive

ML-II Type
AC Servo Drive

AC Servomotors

Linear Motor

Decelerator

Characteristics

● Servo Drives with 100 VAC Input Power for Single-phase input type

Item			R88D-KTA5L	R88D-KT01L	R88D-KT02L	R88D-KT04L
Continuous output current (rms)			1.2A	1.7A	2.5A	4.6A
Input power supply	Main circuit	Power supply capacity	0.4KVA	0.4KVA	0.5KVA	0.9KVA
		Power supply voltage	Single-phase 100 to 115 VAC (85 to 127 V), 50/60 Hz			
		Rated current	1.7A	2.6A	4.3A	7.6A
		Heat value*1	11W	16.6W	21W	25W
	Control circuit	Power supply voltage	Single-phase 100 to 120 VAC (85 to 132 V), 50/60 Hz			
		Heat value*1	4W	4W	4W	4W
Weight			Approx. 0.8 kg	Approx. 0.8kg	Approx. 1.0kg	Approx. 1.6kg
Maximum applicable motor capacity			50W	100W	200W	400W
Applicable Servomotors (R88M-)	3,000 r/min Servomotors	INC	K05030H	K10030L	K20030L	K40030L
		ABS	K05030T	K10030S	K20030S	K40030S
	2,000 r/min Servomotors	ABS	-	-	-	-
		ABS	-	-	-	-

*1. The heat value is given for rated operation.

● Servo Drives with 200 VAC Input Power for Single-phase/Three-phase input type

Item			R88D-KT01H	R88D-KT02H	R88D-KT04H	R88D-KT08H	R88D-KT10H	R88D-KT15H
Continuous output current (rms)			1.2A	1.6A	2.6A	4.1A	5.9A	9.4A
Input power supply	Main circuit	Power supply capacity	0.5KVA	0.5KVA	0.9KVA	1.3KVA	1.8KVA	2.3KVA
		Power supply voltage	Single-phase or Three-phase 200 to 240 VAC (170 to 264 V), 50/60 Hz					
		Rated current	1.6/0.9A*1	2.4/1.3A *1	4.1/2.4A *1	6.6/3.6A *1	9.1/5.2A *1	14.2/8.1A *1
		Heat value*2	14.3/13.7W *1	23/19W *1	33/24W *1	30/35.5W *1	57/49W *1	104/93W *1
	Control circuit	Power supply voltage	Single-phase 200 to 240VAC (170 to 264V), 50/60Hz					
		Heat value*2	4W	4W	4W	4W	7W	7W
Weight			Approx. 0.8kg	Approx. 0.8kg	Approx. 1.1kg	Approx. 1.6kg	Approx. 1.8kg	Approx. 1.8kg
Maximum applicable motor capacity			100W	200W	400W	750W	1kW	1.5kW
Applicable Servomotors (R88M-)	3,000 r/min Servomotors	INC	K05030H K10030H	K20030H	K40030H	K75030H	-	K1K030H K1K530H
		ABS	K05030T K10030T	K20030T	K40030T	K75030T	-	K1K030T K1K530T
	2,000 r/min Servomotors	INC	-	-	-	-	K1K020H	K1K520H
		ABS	-	-	-	-	K1K020T	K1K520T
	1,000 r/min Servomotors	INC	-	-	-	-	-	K90010H
		ABS	-	-	-	-	-	K90010T

*1. The left value is for single-phase input power and the right value is for three-phase input power.

*2. The heat value is given for rated operation.

● Servo Drives with 200 VAC Input Power
for Three-phase input type

Item			R88D-KT20H	R88D-KT30H	R88D-KT50H	R88D-KT75H	R88D-KT150H	
Continuous output current (rms)			13.4A	18.7A	33.0A	44.0A	66.1A	
Input power supply	Main circuit	Power supply capacity	3.3KVA	4.5KVA	7.5KVA	11.0KVA	22.0KVA	
		Power supply voltage	3-phase 200 to 230 VAC (170 to 253 V), 50/60 Hz				3-phase 200 to 230 VAC (170 to 253V) 50/60Hz 280 to 325 VDC (238 to 357V)	
		Rated current	11.8A	15.1A	21.6A	32.0A	58.0A	
		Heat value*1	139W	108W	328W	381W	720W	
	Control circuit	Power supply voltage	Single-phase 200 to 230 VAC (170 to 253 V), 50/60 Hz				Single-phase 200 to 230 VAC (170 to 253V) 50/60Hz 280 to 325 VDC (238 to 357V)	
		Heat value*1	10W	13W	13W	15W	17W	
Weight			Approx. 2.7kg	Approx. 4.8kg	Approx. 4.8kg	Approx. 13.5kg	Approx. 21.0kg	
Maximum applicable motor capacity			2kW	3kW	5kW	7.5kW	15kW	
Applicable Servomotors (R88M-)	3,000 r/min Servomotors	INC	K2K030H	K3K030H	K4K030H K5K030H	-	-	
		ABS	K2K030T	K3K030T	K4K030T K5K030T	-	-	
	2,000 r/min, 1,500 r/min Servomotors	INC	K2K020H	K3K020H	K4K020H K5K020H	-	-	
		ABS	K2K020T	K3K020T	K4K020T K5K020T	K7K515T	K11K015T K15K015T	
	1,000 r/min Servomotors	INC	-	K2K010H	K3K010H	-	-	
		INC	-	K2K010T	K3K010T K4K510T	K6K010T	-	

*1. The heat value is given for rated operation.

● Servo Drives with 400 VAC Input Power
for Three-phase input type

Item			R88D-KT06F	R88D-KT10F	R88D-KT15F	R88D-KT20F	R88D-KT30F	R88D-KT50F	R88D-KT75F	R88D-KT150F	
Continuous output current (rms)			1.5A	2.9A	4.7A	6.7A	9.4A	16.5A	22.0A	33.4A	
Input power supply	Main circuit	Power supply capacity	1.2KVA	1.8KVA	2.3KVA	3.8KVA	4.5KVA	6.0KVA	11.0KVA	22.0KVA	
		Power supply voltage	3-phase 380 to 480 VAC (323 to 528 V), 50/60 Hz								
		Rated current	2.1A	2.8A	3.9A	5.9A	7.6A	12.1A	16.0A	29.0A	
		Heat value*1	32.2W	48W	49W	65W	108W	200W	300W	590W	
	Control circuit	Power supply voltage	24 VDC (20.4 to 27.6)								
		Heat value*1	7W	7W	7W	10W	13W	13W	15W	22W	
Weight			Approx. 1.9kg	Approx. 1.9kg	Approx. 1.9kg	Approx. 2.7kg	Approx. 4.7kg	Approx. 4.7kg	Approx. 13.5kg	Approx. 21.0kg	
Maximum applicable motor capacity			600W	1kW	1.5kW	2kW	3kW	5kW	7.5kW	15kW	
Applicable Servomotors (R88M-)	3,000 r/min Servomotors	INC	-	K75030F	K1K030F K1K530F	K2K030F	K3K030F	K4K030F K5K030F	-	-	
		ABS	-	K75030C	K1K030C K1K530C	K2K030C	K3K030C	K4K030C K5K030C	-	-	
	2,000 r/min, 1,500 r/min Servomotors	INC	K40020F K60020F	K1K020F	K1K520F	K2K020F	K3K020F	K4K020F K5K020F	-	-	
		ABS	K40020C K60020C	K1K020C	K1K520C	K2K020C	K3K020C	K4K020C K5K020C	K7K515C	K11K015C K15K015C	
	1,000 r/min Servomotors	INC	-	-	K90010F	-	K2K010F	K3K010F	-	-	
		ABS	-	-	K90010C	-	K2K010C	K3K010C K4K510C	K6K010C	-	

*1. The heat value is given for rated operation.

Components and Functions

Servo Drive Part Names

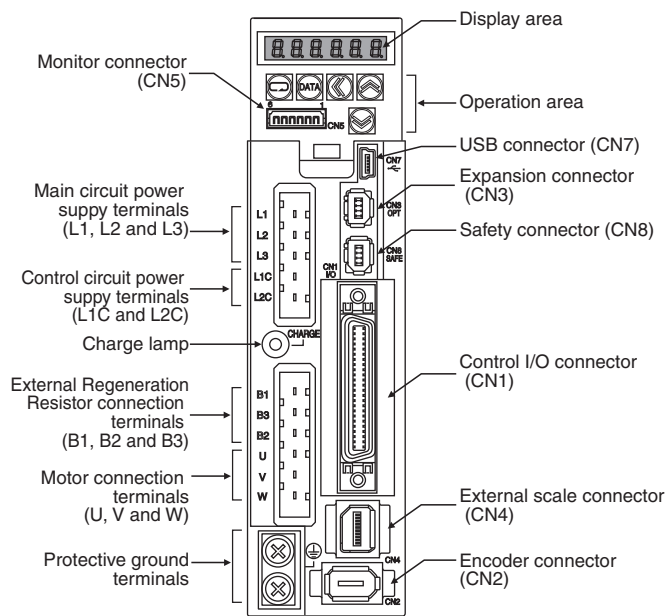

Display area

A 6-digit 7-segment LED display shows the Servo Drive status, alarm codes, parameters, and other information.

Operation area

Monitors the parameter setting and driver condition.

Charge Lamp

Lits when the main circuit power supply is turned ON.

Control I/O Connector (CN1)

Used for command input signals and I/O signals.

Encoder connector (CN2)

Connector for the encoder installed in the Servomotor.

Expansion Connector (CN3)

A spare connector for expansion. Do not connect anything.

External Scale Connector (CN4)

Connector for an encoder signal used during full closing control.

Monitor Connector (CN5)

Uses a specified cable to monitor the motor rotation speed, torque command value, etc.

USB connector (CN7)

Communications connector for the computer.

Safety Connector (CN8)

Connector for the safety devices.

If no safety device is used, keep the factory-set safety bypass connector installed.

Main Circuit Terminal (CNA)

Main-circuit power terminals (L1, L2, L3)

Control-circuit power terminals (CNA)

Motor connection terminals (CNB)

External Regeneration Resistor connection terminals (B1,B2,B3)

Servomotor connection terminals (U, V, W)

*External Encoder

Contact the encoder manufacturer to find out the detailed specifications such as operating environment before use.

External encoder type	Maker	Example of External encoder	Supported speed *1	Resolution *4 [μm]	Maximum speed *4 [m/s]
90° phase difference output type *2 *3	–	Phase A/B type	0 to 4 Mpps (Multiplication × 4)	–	–
Serial communications type (Incremental type) *3	Magnescale Co., Ltd	SL700+PL101RP/RHP SL710+PL101RP/RHP	0 to 400 Mpps	0.1	10
		SR75/SR85		0.01 to 1	3.3
		BF1		0.001/0.01	0.4/1.8
		SQ10+PQ11 SQ10+PQ10+MQ10		0.05/0.1/ 0.5/1	3
	NIDEC SANKYO CORPORATION	PSLH041+PSLG		0.1	6

*1. The supported speed is the internal feedback pulse speed [external encoder pulse/s] of the external encoder that can be processed by the Servo Drive.

Check the instruction manual of the external encoder for the speed range supported by your external encoder.

*2. These are the directions that the Drive counts a 90° phase difference output.

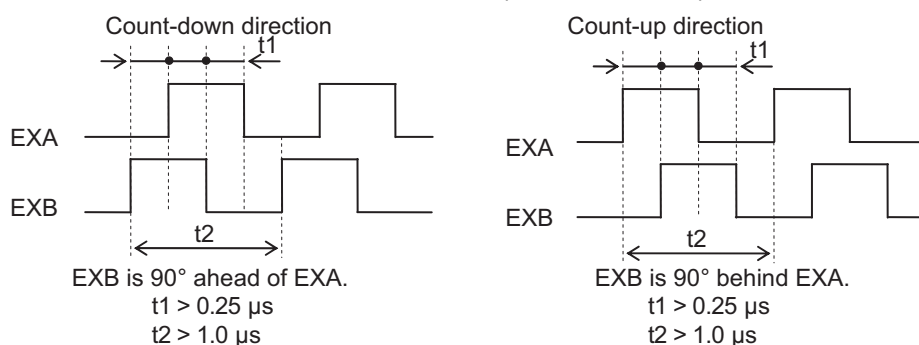

*3. For the external encoder connection direction, set the direction so that count-up occurs when the motor shaft is rotating counterclockwise, and count-down occurs when the motor shaft is rotating clockwise. If the connection direction cannot be selected due to installation conditions or any other reason, the count direction can be reversed using External Feedback Pulse Direction Switching (Pn326).

*4. The resolution and maximum speed are the values for the G5-series Servo Drive. The resolution and maximum speed may be different from the specifications of the feedback encoder due to restriction on the maximum pulse frequency of the Servo Drive.

Functions

Basic control

Position control	Internally set speed control
Speed control	Switching control
Torque control	Full closing control*

* Absolute type external encoder can not connected.

Advanced control

Vibration control	Gain switching	Friction torque compensation function
Adaptive filter	Torque limit	Inertia ratio switching function
Notch filter	Sequence I/O signal	Hybrid Vibration Suppression Function
Electronic gear function	Forward and reverse drive prohibition functions	Feed-forward function
Encoder dividing function	Disturbance observer function	Instantaneous speed observer function
Brake interlock	Gain switching 3 function	

Other functions

Safe Torque OFF (STO) Function

Realtime autotuning

Manual tuning

Various parameters

Basic Parameters	Interface Monitor Setting Parameters
Gain Parameters	Extended Parameters
Vibration Suppression Parameters	Special Parameters
Analog Control Parameters	

Dimensions

<Wall Mounting>

Single-phase 100 VAC R88D-KTA5L/-KT01L (50 to 100W)

Single-phase/Three-phase 200 VAC R88D-KT01H/-KT02H (100 to 200W)

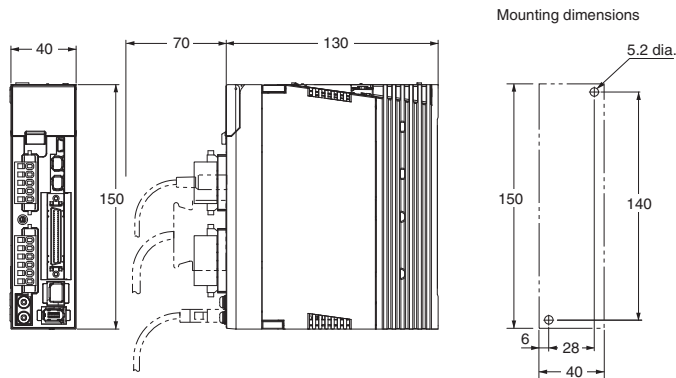

Single-phase/Three-phase 100 VAC R88D-KT02L (200W)

Single-phase/Three-phase 200 VAC R88D-KT04H (400W)

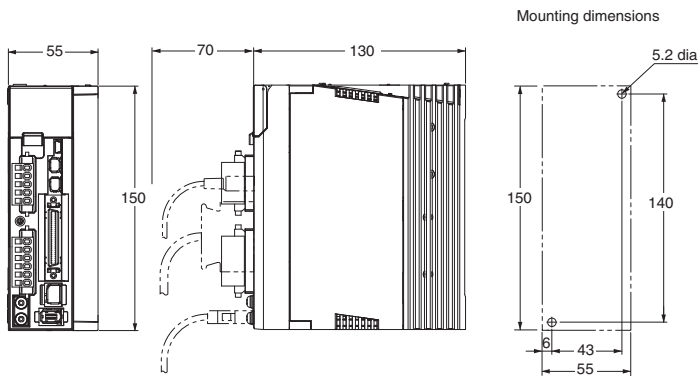

Single-phase 100 VAC R88D-KT04L (400W)

Single-phase/Three-phase 200 VAC R88D-KT08H (750W)

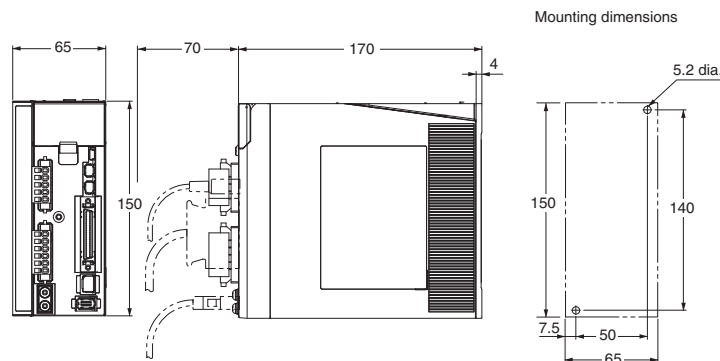

Single-phase/Three-phase 200 VAC R88D-KT10H/-KT15H (900W to 1.5kW)

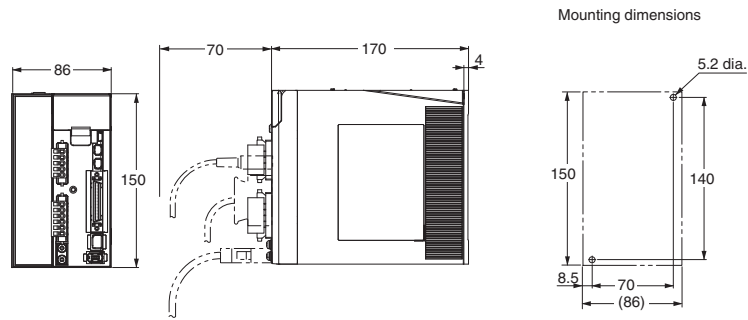

Three-phase 200 VAC R88D-KT20H (2kW)

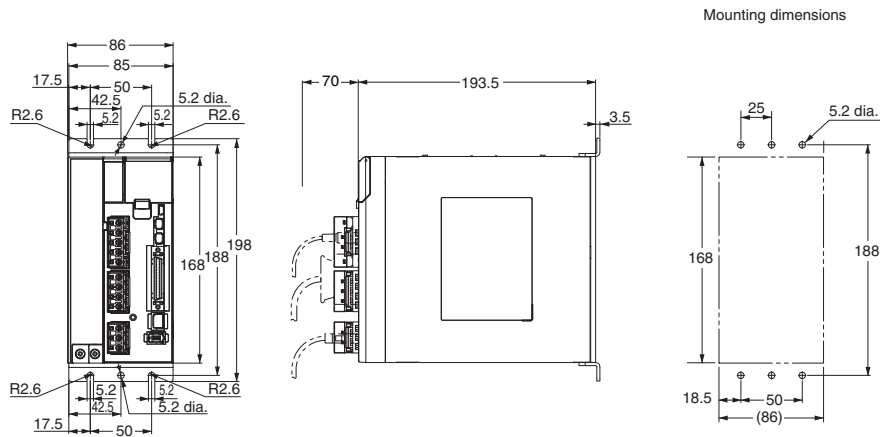

Three-phase 200 VAC R88D-KT30H/-KT50H (3 to 5kW)

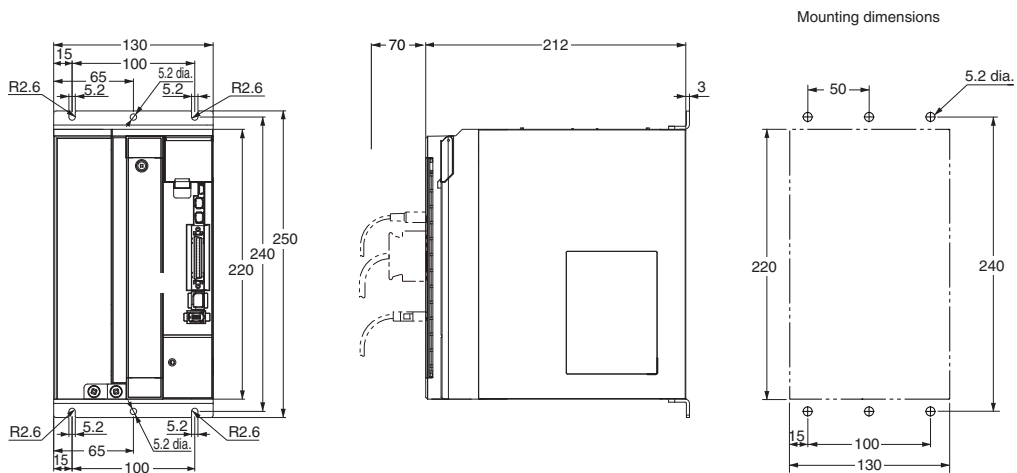

Three-phase 200 VAC R88D-KT75H (7.5kW)

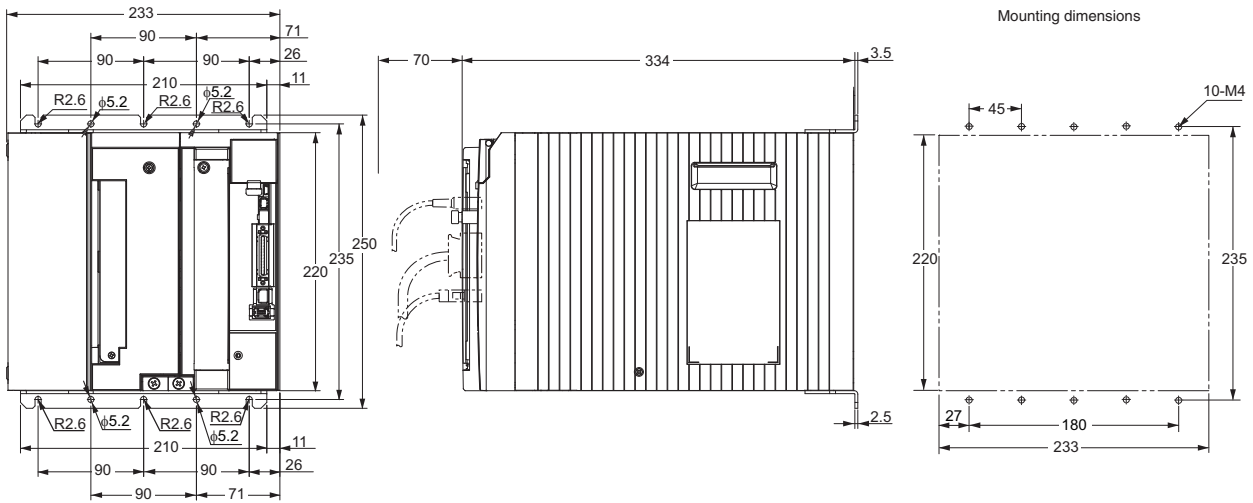

Three-phase 200 VAC R88D-KT150H (15kW)

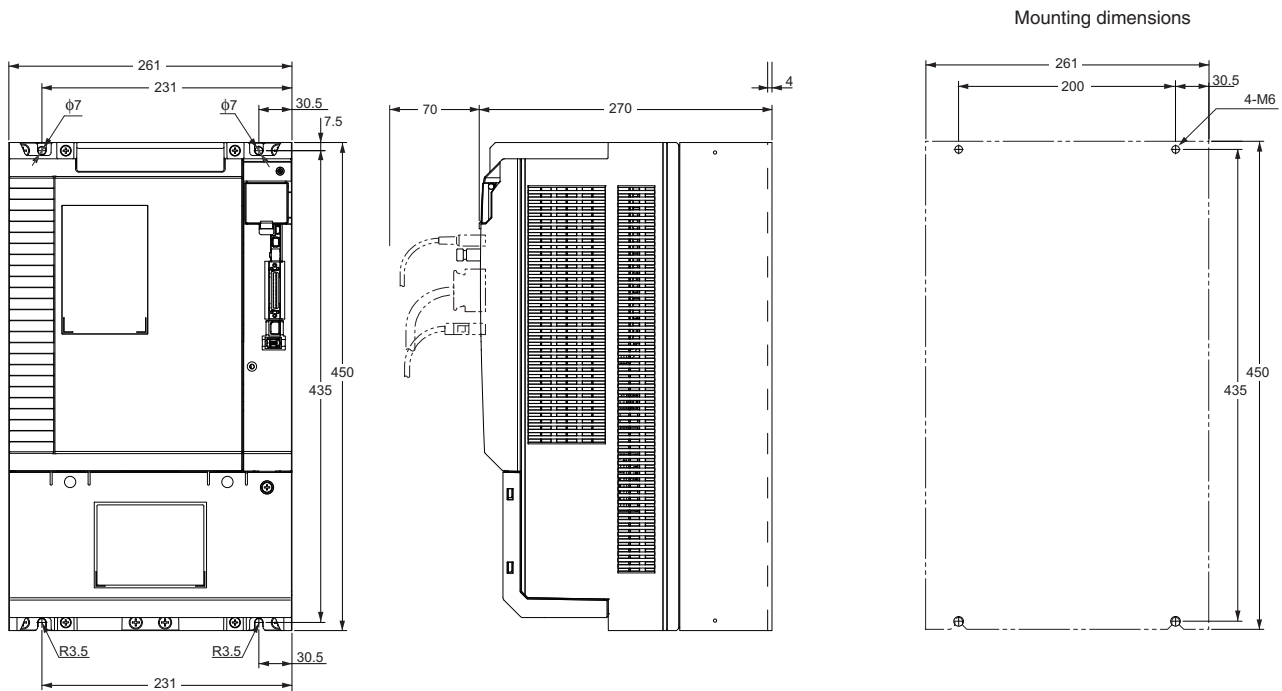

G5-Series
System Configuration

EtherCAT Communications
AC Servo Drive

EtherCAT Communications
Linear Motor Type
AC Servo Drive

General-purpose Inputs
AC Servo Drive

ML-II Type
AC Servo Drive

AC Servomotors

Linear Motor

Decelerator

Three-phase 400 VAC R88D-KT06F/-KT10F/-KT15F (600W to 1.5kW)

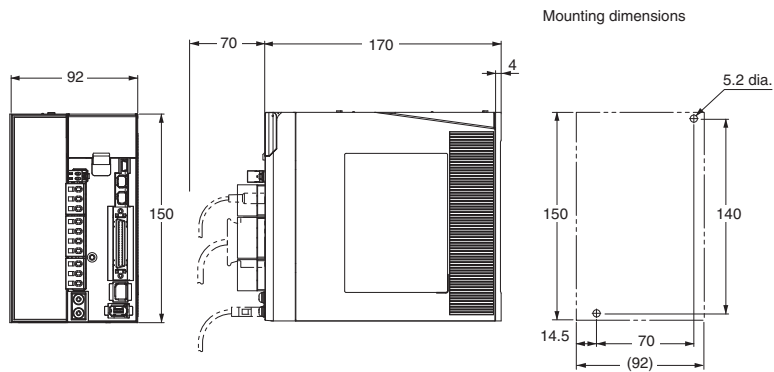

Three-phase 400 VAC R88D-KT20F (2kW)

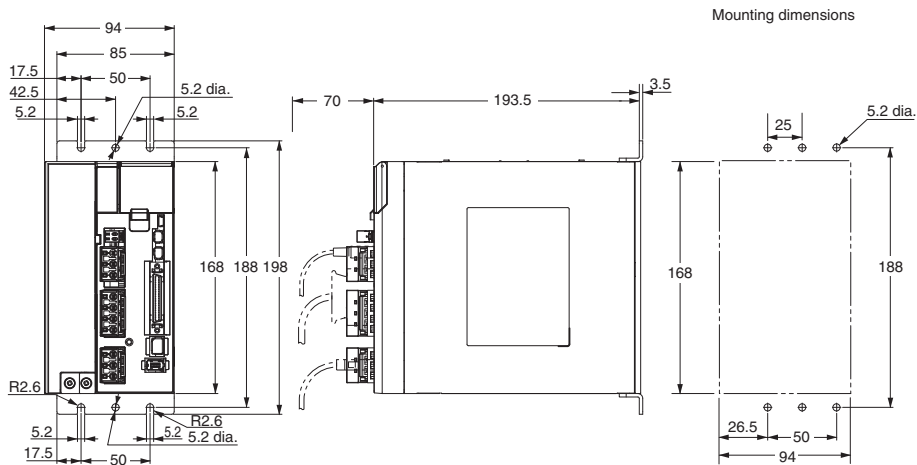

Three-phase 400 VAC R88D-KT30F/-KT50F (3 to 5kW)

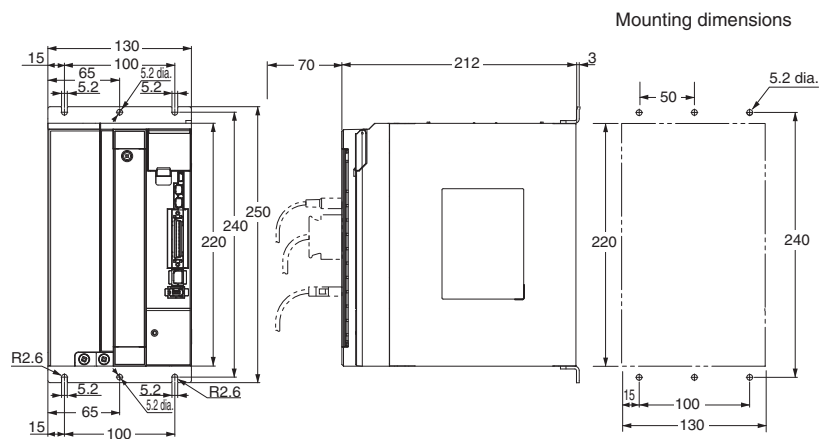

Three-phase 400 VAC: R88D-KT75F (7.5kW)

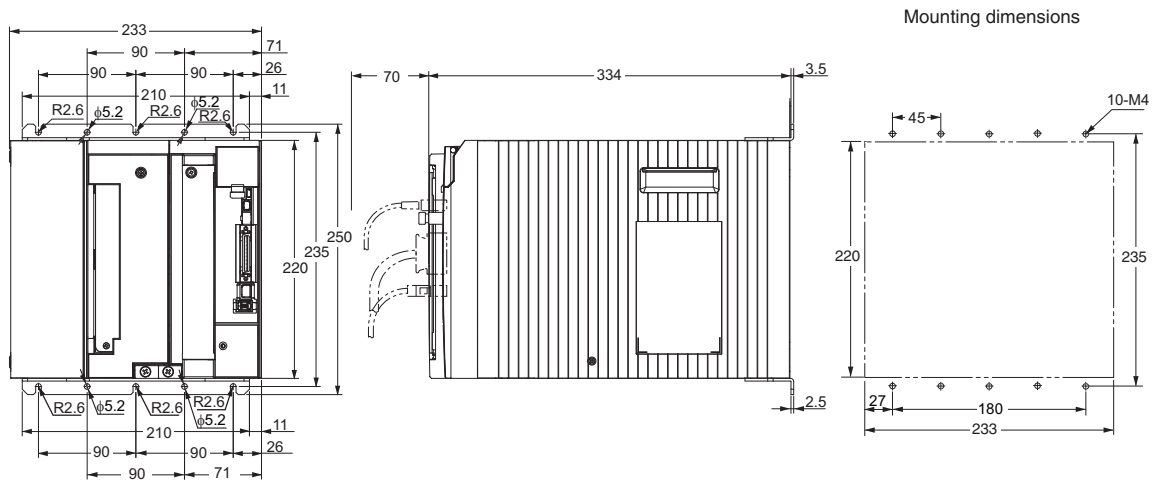

Three-phase 400 VAC R88D-KT150F (150kW)

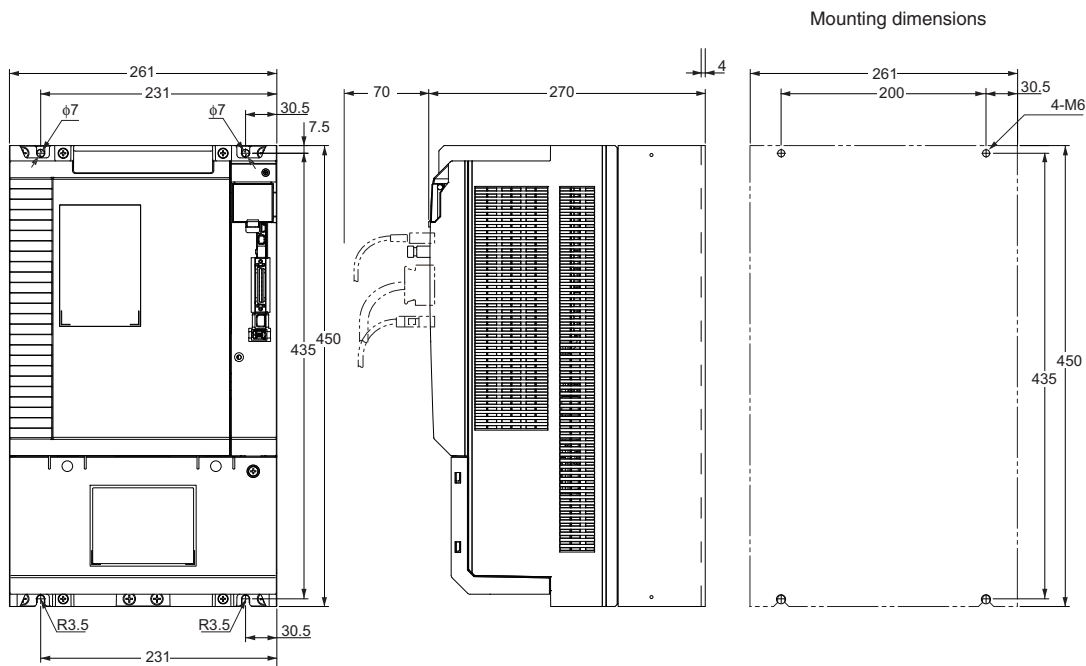

G5-Series
System Configuration

EtherCAT Communications
AC Servo Drive

EtherCAT Communications
Linear Motor Type
AC Servo Drive

General-purpose Inputs
AC Servo Drive

ML-II Type
AC Servo Drive

AC Servomotors

Linear Motor

Decelerator