

G5-series AC Servomotors

R88M-K INC ABS/INC

Contents

- Ordering Information
- Specifications
 - General Specifications
 - Characteristics/Torque and Rotation Speed Characteristics
 - <Cylinder type>
 - 3,000 r/min servomotors (100V, 200V, 400V)
 - 2,000 r/min servomotors (200V, 400V)
 - 1,500 r/min servomotors (200V/400V)
 - 1,000 r/min servomotors (200V/400V)
 - Encoder Specifications
- Dimensions

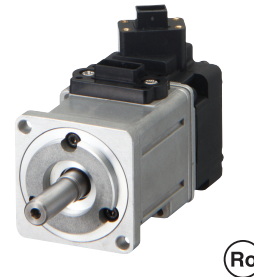

Ordering Information

Refer to the Ordering Information.

Specifications

General Specifications

Item	3,000-r/min motors		1,000-r/min motors 1,500-r/min motors 2,000-r/min motors
	50 to 750W	1 to 5kW	900 W to 15kW
Ambient operating temperature and operating humidity	0 to 40°C 20 to 85% RH (with no condensation)		
Storage ambient temperature and humidity	-20 to +65°C, 20% to 85% RH (with no condensation) Guaranteed maximum temperature: 72 hours at 80°C		
Operating and storage atmosphere	No corrosive gases		
Vibration resistance *1	Acceleration of 49 m/s ² *2 24.5 m/s ² max. in X, Y, and Z directions when the motor is stopped		
Impact resistance	Acceleration of 98 m/s ² max. 3 times each in X, Y, and Z directions		
Insulation resistance	Between power terminal and FG terminal: 20 MΩ min. (at 500 VDC Megger)		
Dielectric strength	1,500 VAC between power terminal and FG terminal (sensed current 10 mA) for 1 min (voltage 100 V, 200 V) 1,800 VAC between power terminal and FG terminal (sensed current 10 mA) for 1 min (voltage 400 V) 1,000 VAC between brake terminal and FG terminal (sensed current 10 mA) for 1 min		
Insulation class	Class B	Class F	
Protective structure	IP67 (except for through-shaft parts and motor and encoder connector pins)		
International standard	EC directive	Low voltage directive	EN60034-1/-5
	UL standards		UL1004-1
	CSA standards		CSA C22.2 No.100
			UL1004-1, UL1004-6 *3

*1. The amplitude may be amplified by machine resonance. Do not exceed 80% of the specified value for extended periods of time.

*2. 24.5m/s² is specified for 1,500-r/min Servomotors of 7.5 to 15 kW and 1,000-r/min Servomotors of 4.5 to 6 kW.

*3. UL 1004-6 applies only to 1,500-r/min Servomotors of 7.5 to 15 kW and 1,000-r/min Servomotors of 4.5 to 6 kW.

Note: 1. Do not use the cable when it is laying in oil or water.

Note: 2. Do not expose the cable outlet or connections to stress due to bending or the weight of the cable itself.

Note: 3. Always disconnect all connections to the Servo Motor before you perform insulation resistance tests on it. If you perform an insulation resistance test while the Servo Motor is connected, the Servo Motor may be damaged. Never perform dielectric strength tests on the Servo Motor. Failure to follow this precaution may result in damaging internal elements.

Note: 4. To conform EMC directive, the tips on wiring and installation written in the G5 series user's manual must be followed. Confirm the Manual No. that is listed in Related Manuals.

Characteristics/Torque and Rotation Speed Characteristics

Characteristics

<Cylinder type>

3,000 r/min Servomotors (100 VAC Input Power)

Model (R88M-)		K05030H	K10030L	K20030L	K40030L	
Item	Unit	K05030T	K10030S	K20030S	K40030S	
Rated output *1	W	50	100	200	400	
Rated torque *1	N • m	0.16	0.32	0.64	1.3	
Rated rotation speed	r/min	3,000				
Momentary maximum rotation speed	r/min	6,000				
Momentary maximum torque*1	N • m	0.48	0.95	1.91	3.8	
Rated current *1	A (rms)	1.1	1.6	2.5	4.6	
Momentary maximum current*1	A (0-p)	4.7	6.9	10.6	19.5	
Rotor inertia	Without brake	kg • m ²	0.025×10 ⁻⁴	0.051×10 ⁻⁴	0.14×10 ⁻⁴	0.26×10 ⁻⁴
	With brake	kg • m ²	0.027×10 ⁻⁴	0.054×10 ⁻⁴	0.16×10 ⁻⁴	0.28×10 ⁻⁴
Applicable load inertia	–	30 times the rotor inertia max. *2				
Torque constant *1	N • m/A	0.11±10%	0.14±10%	0.20±10%	0.21±10%	
Power rate *1	Without brake	kW/s	10.1	19.8	28.9	62.4
	With brake	kW/s	9.4	18.7	25.3	37.8
Mechanical time constant	Without brake	ms	1.43	1.03	0.61	0.48
	With brake	ms	1.54	1.09	0.70	0.52
Electrical time constant	ms	0.82	0.91	3.0	3.4	
Allowable radial load *3	N	68	68	245	245	
Allowable thrust load *3	N	58	58	98	98	
Weight	Without brake	kg	Approx. 0.31	Approx. 0.45	Approx. 0.78	Approx. 1.2
	With brake	kg	Approx. 0.51	Approx. 0.65	Approx. 1.2	Approx. 1.6
Radiator plate dimensions (material)		100×80×t10 (Al)		130×120×t12 (Al)		
Applicable drivers (R88D-)		KTA5L/KNA5L-ML2/ KNA5L-ECT	KT01L/KN01L-ML2/ KN01L-ECT	KT02L/KN02L-ML2/ KN02L-ECT	KT04L/KN04L-ML2/ KN04L-ECT	
Brake specifications	Brake inertia	kg • m ²	2×10 ⁻⁷	2×10 ⁻⁷	1.8×10 ⁻⁶	1.8×10 ⁻⁶
	Excitation voltage *4	V	24 VDC±5%			
	Power consumption (at 20°C)	W	7	7	9	9
	Current consumption (at 20°C)	A	0.3	0.3	0.36	0.36
	Static friction torque	N • m	0.29 min.	0.29 min.	1.27 min.	1.27 min.
	Attraction time	ms	35 max.	35 max.	50 max.	50 max.
	Release time	ms	20 max. *5	20 max. *5	15 max. *5	15 max. *5
	Backlash		±1°			
	Allowable work per braking	J	39.2	39.2	137	137
	Allowable total work	J	4.9×10 ³	4.9×10 ³	44.1×10 ³	44.1×10 ³
	Allowable angular acceleration	rad/s ²	30,000 max. (Speed of 2,800 r/min or more must not be changed in less than 10 ms)			
	Brake limit	–	10 million times min.			
	Rating	–	Continuous			
Insulation class	–	Type F				

*1. These are the values when the motor is combined with a driver at normal temperature (20°C, 65%). The momentary maximum torque indicates the standard value.

*2. Applicable load inertia.

- The operable load inertia ratio (load inertia/rotor inertia) depends on the mechanical configuration and its rigidity. For a machine with high rigidity, operation is possible even with high load inertia. Select an appropriate motor and confirm that operation is possible.
- If the dynamic brake is activated frequently with high load inertia, the Dynamic Brake Resistor may burn. Do not repeatedly turn the servo ON/OFF while the dynamic brake is enabled.
- The dynamic brake is designed only for emergency stops. Design the system so that the Servomotor remains stopped for at least 10 minutes after applying the dynamic brake. Otherwise the dynamic brake circuits may fail.

*3. The allowable radial and thrust loads are the values determined for a limit of 20,000 hours at normal operating temperatures. The allowable radial loads are applied as shown in the following diagram.

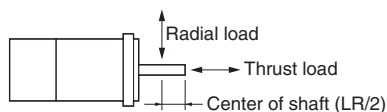

*4. This is a non-excitation brake. (It is released when excitation voltage is applied.)

*5. Direct current switching with a varistor (TNR15G271K by Nippon Chemi-Con Corporation or Z15D271 by Ishizuka Electronics Co.).

Torque and Rotation Speed Characteristics 3,000 r/min Servomotors (100 VAC Input Power)

The following graphs show the characteristics with a 3-m standard cable and a 100 VAC input.

- R88M-K05030H/T (50W)

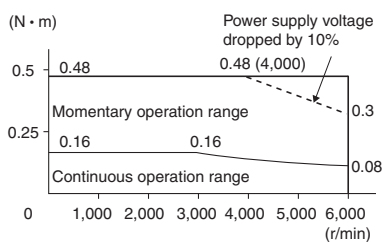

- R88M-K10030L/S (100W)

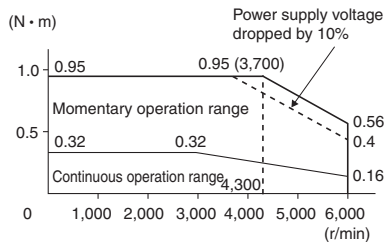

- R88M-K20030L/S (200W)

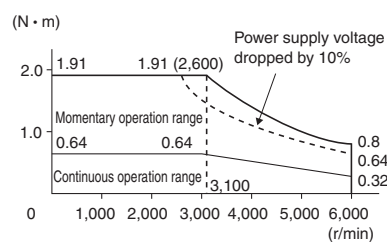

- R88M-K40030L/S (400W)

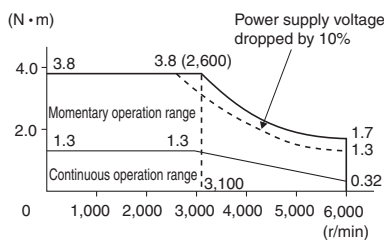

Note 1: The continuous operation range is the range in which continuous operation is possible. Continuous operation at the maximum speed is also possible. However, doing so will reduce the output torque.

Note 2: If the motor power cable exceeds 20 m, the voltage drop will increase and the momentary operation range will become narrower.

AC Servomotor/Drive G5-series

Characteristics

3,000 r/min Servomotors (200 VAC Input Power)

Model (R88M-)		K05030H	K10030H	K20030H	K40030H	K75030H	K1K030H	K1K530H	K2K030H	K3K030H	K4K030H	K5K030H		
Unit		K05030T	K10030T	K20030T	K40030T	K75030T	K1K030T	K1K530T	K2K030T	K3K030T	K4K030T	K5K030T		
Rated output *1	W	50	100	200	400	750	1000	1500	2000	3000	4000	5000		
Rated torque *1	N • m	0.16	0.32	0.64	1.3	2.4	3.18	4.77	6.37	9.55	12.7	15.9		
Rated rotation speed	r/min	3,000												
Momentary maximum rotation speed]	r/min	6,000				5,000				4,500				
Momentary maximum torque *1	N • m	0.48	0.95	1.91	3.8	7.1	9.55	14.3	19.1	28.6	38.2	47.7		
Rated current *1	A (rms)	1.1	1.1	1.5	2.4	4.1	6.6	8.2	11.3	18.1	19.6	24.0		
Momentary maximum current *1	A (0-p)	4.7	4.7	6.5	10.2		28	35	48	77	83	102		
Rotor inertia	Without brake	kg • m ²	0.025×10 ⁻⁴	0.051×10 ⁻⁴	0.14×10 ⁻⁴	0.26×10 ⁻⁴	0.87×10 ⁻⁴	2.03×10 ⁻⁴	2.84×10 ⁻⁴	3.68×10 ⁻⁴	6.50×10 ⁻⁴	12.9×10 ⁻⁴	17.4×10 ⁻⁴	
	With brake	kg • m ²	0.027×10 ⁻⁴	0.054×10 ⁻⁴	0.16×10 ⁻⁴	0.28×10 ⁻⁴	0.97×10 ⁻⁴	2.35×10 ⁻⁴	3.17×10 ⁻⁴	4.01×10 ⁻⁴	6.85×10 ⁻⁴	14.2×10 ⁻⁴	18.6×10 ⁻⁴	
Applicable load inertia	–	30 times the rotor inertia max. *2					20 times the rotor inertia max. *2	15 times the rotor inertia max. *2		15 times the rotor inertia max. *2				
Torque constant *1	N • m/A	0.11±10%	0.21±10%	0.32±10%	0.40±10%	0.45±10%	0.37	0.45	0.44	0.41	0.49	0.49		
Power rate *1	Without brake	kW/s	10.1	19.8	28.9	62.3	65.4	49.8	80.1	110	140	126	146	
	With brake	kW/s	9.4	18.7	25.3	57.8	58.7	43.0	71.8	101	116	114	136	
Mechanical time constant	Without brake	ms	1.43	1.07	0.58	0.43	0.37	0.61	0.49	0.44	0.41	0.51	0.50	
	With brake	ms	1.54	1.13	0.66	0.46	0.42	0.71	0.55	0.48	0.49	0.56	0.54	
Electrical time constant	ms	0.82	0.90	3.2	3.4	5.3	5.8	6.3	6.7	11	12	13		
Allowable radial load *3	N	68	68	245	245	392	490	490	490	490	784	784		
Allowable thrust load *3	N	58	58	98	98	147	196	196	196	196	343	343		
Weight	Without brake	kg	Approx. 0.31	Approx. 0.46	Approx. 0.79	Approx. 1.2	Approx. 2.3	Approx. 3.5	Approx. 4.4	Approx. 5.3	Approx. 8.3	Approx. 11.0	Approx. 14.0	
	With brake	kg	Approx. 0.51	Approx. 0.66	Approx. 1.2	Approx. 1.6	Approx. 3.1	Approx. 4.5	Approx. 5.4	Approx. 6.3	Approx. 9.4	Approx. 12.6	Approx. 16.0	
Radiator plate dimensions (material)		100×80×t10 (Al)			130×120×t12 (Al)		170×160×t12 (Al)	320×300×t20 (Al)			380×350×t30 (Al)			
Applicable drives (R88D-)		KT01H/ KN01H- ML2/ KN01H- ECT	KT01H/ KN01H- ML2/ KN01H- ECT	KT02H/ KN02H- ML2/ KN02H- ECT	KT04H/ KN04H- ML2/ KN04H- ECT	KT08H/ KN08H- ML2/ KN08H- ECT	KT15H/ KN15H- ML2/ KN15H- ECT	KT15H/ KN15H- ML2/ KN15H- ECT	KT20H/ KN20H- ML2/ KN20H- ECT	KT30H/ KN30H- ML2/ KN30H- ECT	KT50H/ KN50H- ML2/ KN50H- ECT	KT50H/ KN50H- ML2/ KN50H- ECT		
Brake specifications	Brake inertia	kg • m ²	2×10 ⁻⁷	2×10 ⁻⁷	1.8×10 ⁻⁶	1.8×10 ⁻⁶	0.75×10 ⁻⁵	0.33×10 ⁻⁴	0.33×10 ⁻⁴	0.33×10 ⁻⁴	0.33×10 ⁻⁴	1.35×10 ⁻⁴	1.35×10 ⁻⁴	
	Excitation voltage *4	V	24 VDC±5%						24 VDC±10%					
	Power consumption (at 20°C)	W	7	7	9	9	10	19	19	19	19	22	22	
	Current consumption (at 20°C)	A	0.3	0.3	0.36	0.36	0.42	0.81±10%	0.81±10±	0.81±10%	0.81±10%	0.90±10%	0.90±10%	
	Static friction torque	N • m	0.29 min.	0.29 min.	1.27 min.	1.27 min.	2.45 min.	7.8 min.	7.8 min.	7.8 min.	11.8 min.	16.1 min.	16.1 min.	
	Attraction time	ms	35 max.	35 max.	50 max.	50 max.	70 max.	50 max.	50 max.	50 max.	80 max.	110 max.	110 max.	
	Release time	ms	20 max. *5	20 max. *5	15 max. *5	15 max. *5	20 max. *5	15 max. *6	15 max. *6	15 max. *6	15 max. *6	50 max. *7	50 max. *7	
	Backlash		±1°											
	Allowable work per braking	J	39.2	39.2	137	137	196	392	392	392	392	1470	1470	
	Allowable total work	J	4.9×10 ³	4.9×10 ³	44.1×10 ³	44.1×10 ³	1.47×10 ⁵	4.9×10 ⁵	4.9×10 ⁵	4.9×10 ⁵	4.9×10 ⁵	2.2×10 ⁶	2.2×10 ⁶	
	Allowable angular acceleration	rad/s ²	30,000 max. (Speed of 2,800 r/min or more must not be changed in less than 10 ms)						10,000					
	Brake limit	–	10 million times min.											
	Rating	–	Continuous											
Insulation class	–	Type F												

*1. These are the values when the motor is combined with a driver at normal temperature (20°C, 65%). The momentary maximum torque indicates the standard value.

*2. Applicable load inertia.

- The operable load inertia ratio (load inertia/rotor inertia) depends on the mechanical configuration and its rigidity. For a machine with high rigidity, operation is possible even with high load inertia. Select an appropriate motor and confirm that operation is possible.
- If the dynamic brake is activated frequently with high load inertia, the Dynamic Brake Resistor may burn. Do not repeatedly turn the servo ON/OFF while the dynamic brake is enabled.
- The dynamic brake is designed only for emergency stops. Design the system so that the Servomotor remains stopped for at least 10 minutes after applying the dynamic brake. Otherwise the dynamic brake circuits may fail.

*3. The allowable radial and thrust loads are the values determined for a limit of 20,000 hours at normal operating temperatures. The allowable radial loads are applied as shown in the following diagram.

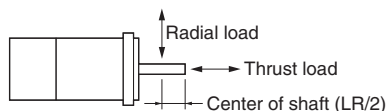

*4. This is a non-excitation brake. (It is released when excitation voltage is applied.)

*5. Direct current switching with a varistor (TNR15G271K by Nippon Chemi-Con Corporation or Z15D271 by Ishizuka Electronics Co.).

*6. Direct current switching with a varistor (Z15D151 by Ishizuka Electronics Co.).

*7. Direct current switching with a varistor (TNR9G820K by Nippon Chemi-Con Corporation).

Torque and Rotation Speed Characteristics 3,000 r/min Servomotors (200 VAC Input Power)

The following graphs show the characteristics with a 3 m standard cable and a 200 VAC input.

• R88M-K05030H/T (50W)

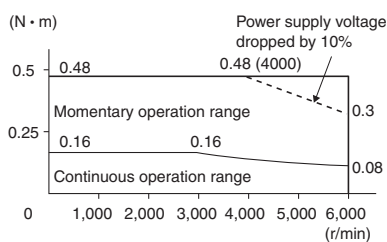

• R88M-K10030H/T (100W)

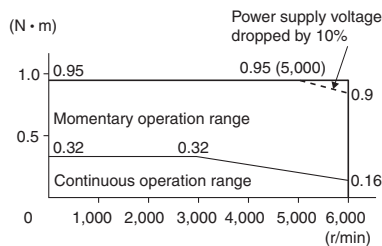

• R88M-K20030H/T (200W)

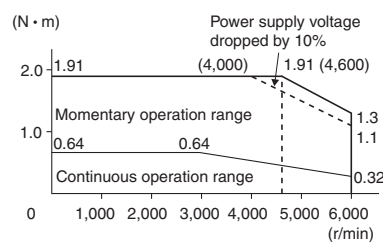

• R88M-K40030H/T (400W)

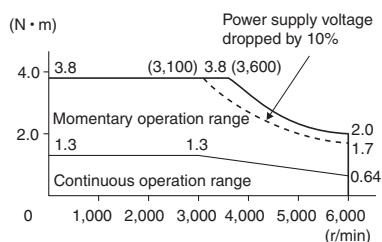

• R88M-K75030H/T (750W)

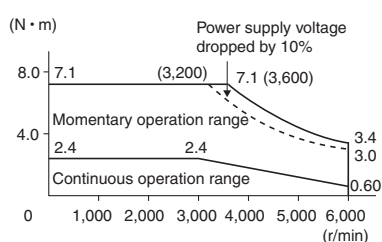

• R88M-K1K030H/T (1kW)

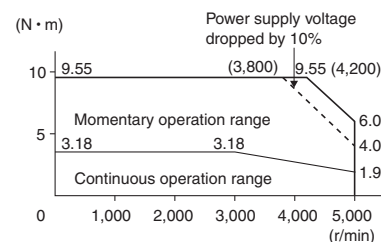

• R88M-K1K530H/T (1.5kW)

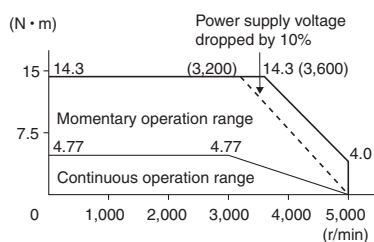

• R88M-K2K030H/T (2kW)

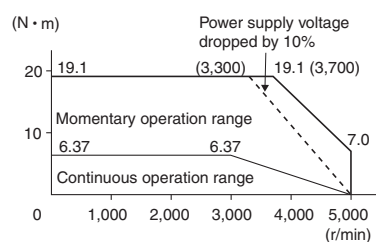

• R88M-K3K030H/T (3kW)

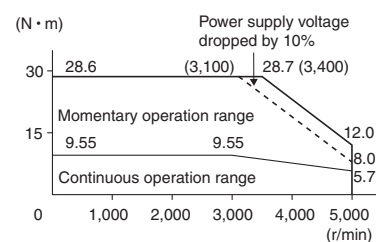

• R88M-K4K030H/T (4kW)

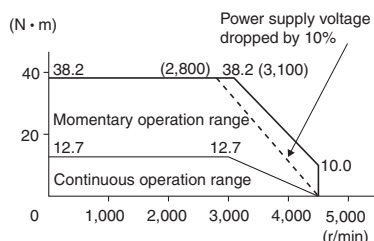

• R88M-K5K030H/T (5kW)

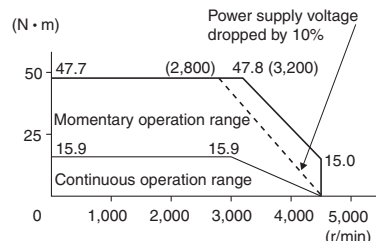

Note 1: The continuous operation range is the range in which continuous operation is possible. Continuous operation at the maximum speed is also possible. However, doing so will reduce the output torque.

Note 2: If the motor power cable exceeds 20 m, the voltage drop will increase and the momentary operation range will become narrower.

AC Servomotor/Drive G5-series

Characteristics

3,000 r/min Servomotors (400 VAC Input Power)

Item		Model (R88M-) Unit	K75030F	K1K030F	K1K530F	K2K030F	K3K030F	K4K030F	K5K030F	
			K75030C	K1K030C	K1K530C	K2K030C	K3K030C	K4K030C	K5K030C	
Rated output *1		W	750	1,000	1,500	2,000	3,000	4,000	5,000	
Rated torque *1		N • m	2.39	3.18	4.77	6.37	9.55	12.7	15.9	
Rated rotation speed		r/min	3,000							
Momentary maximum rotation speed		r/min	5,000				4,500			
Momentary maximum torque*1		N • m	7.16	9.55	14.3	19.1	28.6	38.2	47.7	
Rated current *1		A (rms)	2.4	3.3	4.2	5.7	9.2	9.9	12.0	
Momentary maximum current *1		A (0-p)	10	14	18	24	39	42	51	
Rotor inertia	Without brake	kg • m ²	1.61×10 ⁻⁴	2.03×10 ⁻⁴	2.84×10 ⁻⁴	3.68×10 ⁻⁴	6.50×10 ⁻⁴	12.9×10 ⁻⁴	17.4×10 ⁻⁴	
	With brake	kg • m ²	1.93×10 ⁻⁴	2.35×10 ⁻⁴	3.17×10 ⁻⁴	4.01×10 ⁻⁴	7.85×10 ⁻⁴	14.2×10 ⁻⁴	18.6×10 ⁻⁴	
Applicable load inertia		–	20 times the rotor inertia max. *2		15 times the rotor inertia max. *2					
Torque constant *1		N • m/A	0.78	0.75	0.89	0.87	0.81	0.98	0.98	
Power rate *1	Without brake	kW/s	35.5	49.8	80.1	110	140	126	146	
	With brake	kW/s	29.6	43	71.8	101	116	114	136	
Mechanical time constant	Without brake	ms	0.67	0.60	0.49	0.45	0.40	0.51	0.50	
	With brake	ms	0.8	0.70	0.55	0.49	0.49	0.56	0.54	
Electrical time constant		ms	5.9	5.8	6.5	6.6	12	13	13	
Allowable radial load *3		N	490	490	490	490	490	784	784	
Allowable thrust load *3		N	196	196	196	196	196	343	343	
Weight	Without brake	kg	Approx. 3.1	Approx. 3.5	Approx. 4.4	Approx. 5.3	Approx. 8.3	Approx. 11.0	Approx. 14.0	
	With brake	kg	Approx. 4.1	Approx. 4.5	Approx. 5.4	Approx. 6.3	Approx. 9.4	Approx. 12.6	Approx. 16.0	
Radiator plate dimensions (material)			320×300×t20 (Al)				380×350×t30 (Al)			
Applicable drives (R88D-)			KT10F/ KN10F-ML2/ KN10F-ECT	KT15F/ KN15F-ML2/ KN15F-ECT	KT15F/ KN15F-ML2/ KN15F-ECT	KT20F/ KN20F-ML2/ KN20F-ECT	KT30F/ KN30F-ML2/ KN30F-ECT	KT50F/ KN50F-ML2/ KN50F-ECT	KT50F/ KN50F-ML2/ KN50F-ECT	
Brake specifications	Brake inertia	kg • m ²	0.33×10 ⁻⁴	0.33×10 ⁻⁴	0.33×10 ⁻⁴	0.33×10 ⁻⁴	0.33×10 ⁻⁴	1.35×10 ⁻⁴	1.35×10 ⁻⁴	
	Excitation voltage *4	V	24 VDC±10%							
	Power consumption (at 20°C)	W	17	19	19	19	19	22	22	
	Current consumption (at 20°C)	A	0.70±10%	0.81±10%	0.81±10%	0.81±10%	0.81±10%	0.90±10%	0.90±10%	
	Static friction torque	N • m	2.5 min.	7.8 min.	7.8 min.	7.8 min.	11.8 min.	16.1 min.	16.1 min.	
	Attraction time	ms	50 max.	50 max.	50 max.	50 max.	80 max.	110 max.	110 max.	
	Release time	ms	15 max. *5	15 max. *5	15 max. *5	15 max. *5	15 max. *5	50 max. *6	50 max. *6	
	Backlash		±1°							
	Allowable work per braking	J	392	392	392	392	392	1470	1470	
	Allowable total work	J	4.9×10 ⁵	4.9×10 ⁵	4.9×10 ⁵	4.9×10 ⁵	4.9×10 ⁵	2.2×10 ⁶	2.2×10 ⁶	
	Allowable angular acceleration	rad/s ²	10,000							
	Brake limit	–	10 million times min.							
	Rating	–	Continuous							
Insulation class	–	Type F								

*1. These are the values when the motor is combined with a driver at normal temperature (20°C, 65%). The momentary maximum torque indicates the standard value.

*2. Applicable load inertia.

- The operable load inertia ratio (load inertia/rotor inertia) depends on the mechanical configuration and its rigidity. For a machine with high rigidity, operation is possible even with high load inertia. Select an appropriate motor and confirm that operation is possible.
- If the dynamic brake is activated frequently with high load inertia, the Dynamic Brake Resistor may burn. Do not repeatedly turn the servo ON/OFF while the dynamic brake is enabled.
- The dynamic brake is designed only for emergency stops. Design the system so that the Servomotor remains stopped for at least 10 minutes after applying the dynamic brake. Otherwise the dynamic brake circuits may fail.

*3. The allowable radial and thrust loads are the values determined for a limit of 20,000 hours at normal operating temperatures. The allowable radial loads are applied as shown in the following diagram.

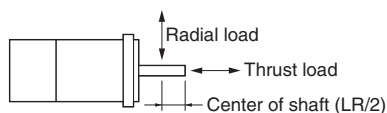

*4. This is a non-excitation brake. (It is released when excitation voltage is applied.)

*5. Direct current switching with a varistor (Z15D151 by Ishizuka Electronics Co.).

*6. Direct current switching with a varistor (TNR9G820K by Nippon Chemi-Con Corporation).

Torque and Rotation Speed Characteristics 3,000 r/min Servomotors (400 VAC Input Power)

The following graphs show the characteristics with a 3 m standard cable and a 400 VAC input.

- R88M-K75030F/C (750W)

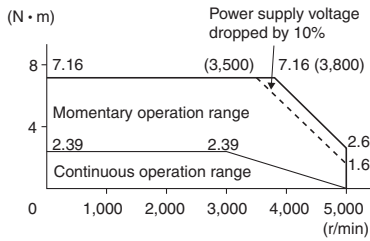

- R88M-K1K030F/C (1kW)

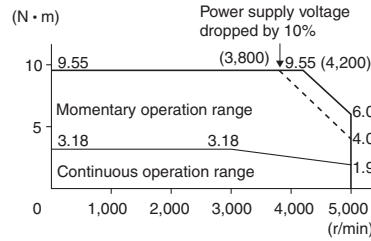

- R88M-K1K530F/C (1.5kW)

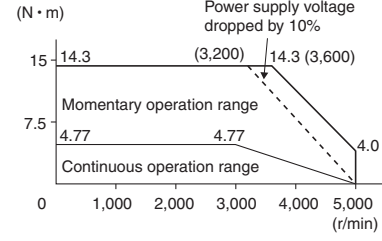

- R88M-K2K030F/C (2kW)

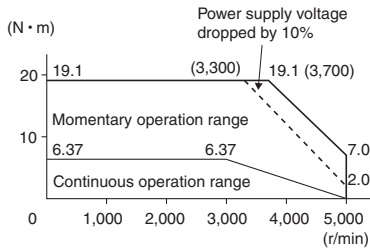

- R88M-K3K030F/C (3kW)

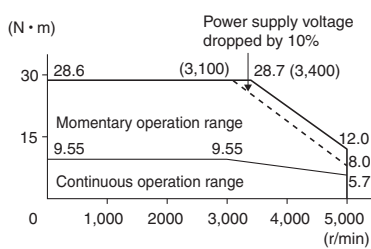

- R88M-K4K030F/C (4kW)

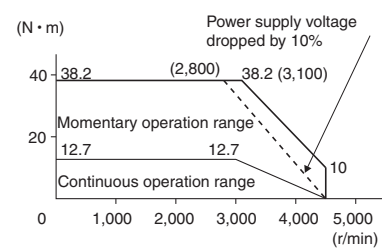

- R88M-K5K030F/C (5kW)

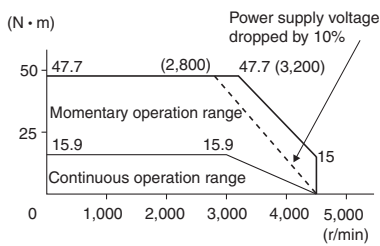

Note 1: The continuous operation range is the range in which continuous operation is possible. Continuous operation at the maximum speed is also possible. However, doing so will reduce the output torque.

Note 2: If the motor power cable exceeds 20 m, the voltage drop will increase and the momentary operation range will become narrower.

AC Servomotor/Drive G5-series

Characteristics

1,500 r/min, 2,000 r/min Servomotors (200 VAC Input Power)

Model (R88M-)		K1K020H	K1K520H	K2K020H	K3K020H	K4K020H	K5K020H	—	—	—	
Item	Unit	K1K020T	K1K520T	K2K020T	K3K020T	K4K020T	K5K020T	K7K515T	K11K015T	K15K015T	
Rated output *1	W	1,000	1,500	2,000	3,000	4,000	5,000	7,500	11,000	15,000	
Rated torque *1	N • m	4.77	7.16	9.55	14.3	19.1	23.9	47.8	70.0	95.0	
Rated rotation speed	r/min	2,000						1,500			
Momentary maximum rotation speed	r/min	3,000						3,000	2,000		
Momentary maximum torque *1	N • m	14.3	21.5	28.6	43.0	57.3	71.6	119.0	175.0	224.0	
Rated current *1	A (rms)	5.7	9.4	11.5	17.4	21.0	25.9	44.0	54.2	66.1	
Momentary maximum current *1	A (0-p)	24	40	49	74	89	110	165	203	236	
Rotor inertia	Without brake	kg • m ²	4.60×10 ⁻⁴	6.70×10 ⁻⁴	8.72×10 ⁻⁴	12.9×10 ⁻⁴	37.6×10 ⁻⁴	48.0×10 ⁻⁴	101×10 ⁻⁴	212×10 ⁻⁴	302×10 ⁻⁴
	With brake	kg • m ²	5.90×10 ⁻⁴	7.99×10 ⁻⁴	10.0×10 ⁻⁴	14.2×10 ⁻⁴	38.6×10 ⁻⁴	48.8×10 ⁻⁴	107×10 ⁻⁴	220×10 ⁻⁴	311×10 ⁻⁴
Applicable load inertia	—	10 times the rotor inertia max. *2									
Torque constant *1	N • m/A	0.63	0.58	0.64	0.59	0.70	0.70	0.77	0.92	1.05	
Power rate *1	Without brake	kW/s	49.5	76.5	105	159	97.1	119	226	231	302
	With brake	kW/s	38.6	64.2	91.2	144	94.5	117	213	223	293
Mechanical time constant	Without brake	ms	0.80	0.66	0.66	0.57	0.65	0.63	0.58	0.80	0.71
	With brake	ms	1.02	0.80	0.76	0.63	0.66	0.64	0.61	0.83	0.74
Electrical time constant	ms	9.4	10	10	12	20	19	21	31	32	
Allowable radial load *3	N	490	490	490	784	784	784	1,176	2,254	2,254	
Allowable thrust load *3	N	196	196	196	343	343	343	490	686	686	
Weight	Without brake	kg	Approx. 5.2	Approx. 6.7	Approx. 8.0	Approx. 11.0	Approx. 15.5	Approx. 18.6	Approx. 36.4	Approx. 52.7	Approx. 70.2
	With brake	kg	Approx. 6.7	Approx. 8.2	Approx. 9.5	Approx. 12.6	Approx. 18.7	Approx. 21.8	Approx. 40.4	Approx. 58.9	Approx. 76.3
Radiator plate dimensions (material)		275×260×t15 (Al)			380×350×t30 (Al)	470×440×t30 (Al)		550×520×t30 (Al)	670×630×t35 (Al)		
Applicable drives (R88D-)		KT10H/ KN10H- ML2/ KN10H- ECT	KT15H/ KN15H- ML2/ KN15H- ECT	KT20H/ KN20H- ML2/ KN20H- ECT	KT30H/ KN30H- ML2/ KN30H- ECT	KT50H/ KN50H- ML2/ KN50H- ECT	KT50H/ KN50H- ML2/ KN50H- ECT	KT75H/ KN75H- ECT	KT150H/ KN150H- ECT	KT150H/ KN150H- ECT	
Brake specifications	Brake inertia	kg • m ²	1.35×10 ⁻⁴	1.35×10 ⁻⁴	1.35×10 ⁻⁴	1.35×10 ⁻⁴	4.7×10 ⁻⁴	4.7×10 ⁻⁴	4.7×10 ⁻⁴	7.1×10 ⁻⁴	7.1×10 ⁻⁴
	Excitation voltage *4	V	24 VDC±10%								
	Power consumption (at 20°C)	W	14	19	19	22	31	31	34	26	26
	Current consumption (at 20°C)	A	0.59±10%	0.79±10%	0.79±10%	0.90±10%	1.3±10%	1.3±10%	1.4±10%	1.08±10%	1.08±10%
	Static friction torque	N • m	4.9 min.	13.7 min.	13.7 min.	16.2 min.	24.5 min.	24.5 min.	58.8 min.	100 min.	100 min.
	Attraction time	ms	80 max.	100 max.	100 max.	110 max.	80 max.	80 max.	150 max.	300 max.	300 max.
	Release time	ms	70 max. *5	50 max. *5	50 max. *5	50 max. *5	25 max. *6	25 max. *6	50 max. *6	140 max. *7	140 max. *7
	Backlash		±1°								
	Allowable work per braking	J	588	1,176	1,176	1,470	1,372	1,372	1,372	2,000	2,000
	Allowable total work	J	7.8×10 ⁵	1.5×10 ⁶	1.5×10 ⁶	2.2×10 ⁶	2.9×10 ⁶	2.9×10 ⁶	2.9×10 ⁶	4.0×10 ⁶	4.0×10 ⁶
	Allowable angular acceleration	rad/s ²	10,000						5,000	3,000	
	Brake limit	—	10 million times min.								
	Rating	—	Continuous								
Insulation class	—	Type F									

*1. These are the values when the motor is combined with a driver at normal temperature (20°C, 65%). The momentary maximum torque indicates the standard value.

*2. Applicable load inertia.

- The operable load inertia ratio (load inertia/rotor inertia) depends on the mechanical configuration and its rigidity. For a machine with high rigidity, operation is possible even with high load inertia. Select an appropriate motor and confirm that operation is possible.
- If the dynamic brake is activated frequently with high load inertia, the Dynamic Brake Resistor may burn. Do not repeatedly turn the servo ON/OFF while the dynamic brake is enabled.
- The dynamic brake is designed only for emergency stops. Design the system so that the Servomotor remains stopped for at least 10 minutes after applying the dynamic brake. Otherwise the dynamic brake circuits may fail.

*3. The allowable radial and thrust loads are the values determined for a limit of 20,000 hours at normal operating temperatures. The allowable radial loads are applied as shown in the following diagram.

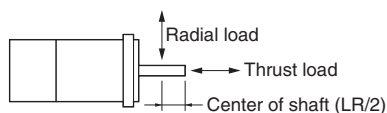

*4. This is a non-excitation brake. (It is released when excitation voltage is applied.)

*5. Direct current switching with a varistor (TNR9G820K by Nippon Chemi-Con Corporation).

*6. Direct current switching with a varistor (Z15D151 by Ishizuka Electronics Co.).

*7. Direct current switching with a varistor (NVD07SCD082 by KOA SPEER ELECTRONICS, INC.).

Torque and Rotation Speed Characteristics

1,500 r/min, 2,000 r/min Servomotors (200 VAC Input Power)

The following graphs show the characteristics with a 3 m standard cable and a 200 VAC input.

- R88M-K1K020H/T (1kW)

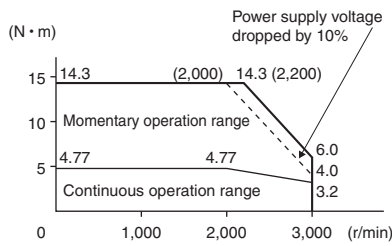

- R88M-K1K520H/T (1.5kW)

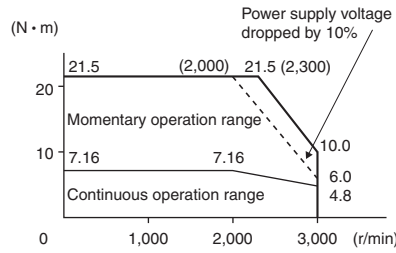

- R88M-K2K020H/T (2kW)

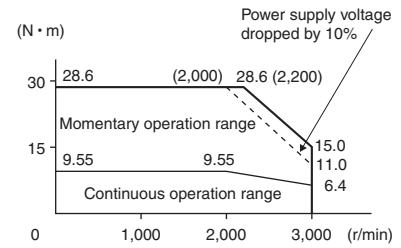

- R88M-K3K020H/T (3kW)

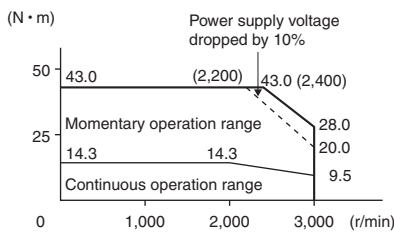

- R88M-K4K020H/T (4kW)

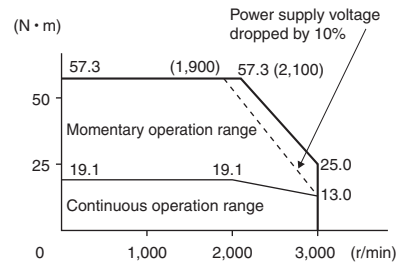

- R88M-K5K020H/T (5kW)

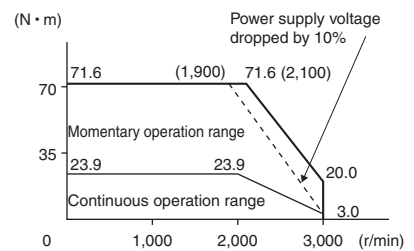

- R88M-K7K515T (7.5kW)

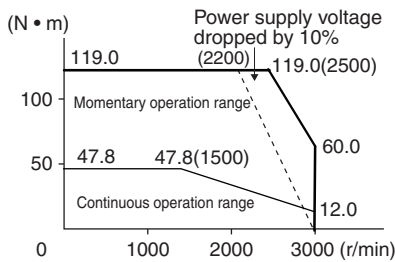

- R88M-K11K015T (11kW)

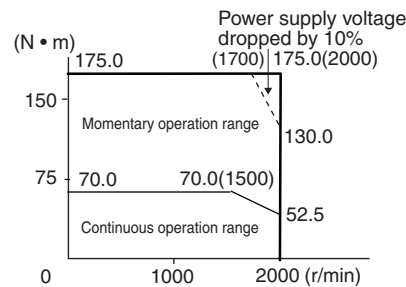

- R88M-K15K015T (15kW)

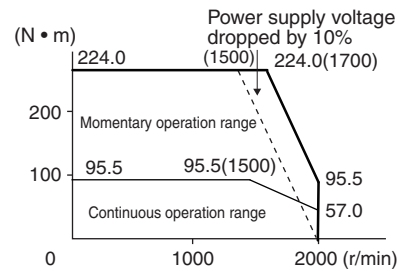

Note 1: The continuous operation range is the range in which continuous operation is possible. Continuous operation at the maximum speed is also possible. However, doing so will reduce the output torque.

Note 2: If the motor power cable exceeds 20 m, the voltage drop will increase and the momentary operation range will become narrower.

AC Servomotor/Drive G5-series

Characteristics

1,500 r/min, 2,000 r/min Servomotors (400 VAC Input Power)

Model (R88M-)		K40020F	K60020F	K1K020F	K1K520F	K2K020F	K3K020F	K4K020F	K5K020F	—	—	—		
Item		Unit	K40020C	K60020C	K1K020C	K1K520C	K2K020C	K3K020C	K4K020C	K5K020C	K7K515C	K11K015C	K15K015C	
Rated output *1		W	400	600	1,000	1,500	2,000	3,000	4,000	5,000	7,500	11,000	15,000	
Rated torque *1		N • m	1.91	2.86	4.77	7.16	9.55	14.3	19.1	23.9	47.8	70.0	95.9	
Rated rotation speed		r/min	2,000									1,500		
Momentary maximum rotation speed		r/min	3,000									2,000		
Momentary maximum torque *1		N • m	5.73	8.59	14.3	21.5	28.7	43.0	57.3	71.6	119.0	175.0	224.0	
Rated current *1		A (rms)	1.2	1.5	2.8	4.7	5.9	8.7	10.6	13.0	22.0	27.1	33.1	
Momentary maximum current *1		A (0-p)	4.9	6.5	12	20	25	37	45	55	83	101	118	
Rotor inertia	Without brake	kg • m ²	1.61×10 ⁻⁴	2.03×10 ⁻⁴	4.60×10 ⁻⁴	6.70×10 ⁻⁴	8.72×10 ⁻⁴	12.9×10 ⁻⁴	37.6×10 ⁻⁴	48.0×10 ⁻⁴	101×10 ⁻⁴	212×10 ⁻⁴	302×10 ⁻⁴	
	With brake	kg • m ²	1.90×10 ⁻⁴	2.35×10 ⁻⁴	5.90×10 ⁻⁴	7.99×10 ⁻⁴	10.0×10 ⁻⁴	14.2×10 ⁻⁴	38.6×10 ⁻⁴	48.8×10 ⁻⁴	107×10 ⁻⁴	220×10 ⁻⁴	311×10 ⁻⁴	
Applicable load inertia		—	10 times the rotor inertia max. *2											
Torque constant *1		N • m/A	1.27	1.38	1.27	1.16	1.27	1.18	1.40	1.46	1.54	1.84	2.10	
Power rate *1	Without brake	kW/s	22.7	40.3	49.5	76.5	105	159	97.1	119	226	231	302	
	With brake	kW/s	19.2	34.8	38.6	64.2	91.2	144	94.5	117	213	223	293	
Mechanical time constant	Without brake	ms	0.70	0.62	0.79	0.66	0.68	0.56	0.60	0.60	0.58	0.80	0.71	
	With brake	ms	0.83	0.72	1.01	0.79	0.78	0.61	0.61	0.61	0.61	0.83	0.74	
Electrical time constant		ms	5.7	5.9	10	10	10	12	21	19	21	31	32	
Allowable radial load *3		N	490	490	490	490	490	784	784	784	1,176	2,254	2,254	
Allowable thrust load *3		N	196	196	196	196	196	343	343	343	490	686	686	
Weight	Without brake	kg	Approx. 3.1	Approx. 3.5	Approx. 5.2	Approx. 6.7	Approx. 8.0	Approx. 11.0	Approx. 15.5	Approx. 18.6	Approx. 36.4	Approx. 52.7	Approx. 70.2	
	With brake	kg	Approx. 4.1	Approx. 4.5	Approx. 6.7	Approx. 8.2	Approx. 9.5	Approx. 12.6	Approx. 18.7	Approx. 21.8	Approx. 40.4	Approx. 58.9	Approx. 76.3	
Radiator plate dimensions (material)			320×300×t20 (Al)			275×260×t15 (Al)			380×350×t30 (Al)	470×440×t30 (Al)		550×520×t30 (Al)	670×630×t35 (Al)	
Applicable drives (R88D-)			KT06F/ KN06F- ML2/ KN06F- ECT	KT06F/ KN06F- ML2/ KN06F- ECT	KT10F/ KN10F- ML2/ KN10F- ECT	KT15F/ KN15F- ML2/ KN15F- ECT	KT20F/ KN20F- ML2/ KN20F- ECT	KT30F/ KN30F- ML2/ KN30F- ECT	KT50F/ KN50F- ML2/ KN50F- ECT	KT50F/ KN50F- ML2/ KN50F- ECT	KT75F/ KN75F- ECT	KT150F/ KN150F- ECT	KT150F/ KN150F- ECT	
Brake specifications	Brake inertia	kg • m ²	1.35×10 ⁻⁴	1.35×10 ⁻⁴	1.35×10 ⁻⁴	1.35×10 ⁻⁴	1.35×10 ⁻⁴	1.35×10 ⁻⁴	4.7×10 ⁻⁴	4.7×10 ⁻⁴	4.7×10 ⁻⁴	7.1×10 ⁻⁴	7.1×10 ⁻⁴	
	Excitation voltage *4	V	24 VDC±10%											
	Power consumption (at 20°C)	W	17	17	14	19	19	22	31	31	34	26	26	
	Current consumption (at 20°C)	A	0.70±10%	0.70±10%	0.59±10%	0.79±10%	0.79±10%	0.90±10%	1.3±10%	1.3±10%	1.4±10%	1.08±10%	1.08±10%	
	Static friction torque	N • m	2.5 min.	2.5 min.	4.9 min.	13.7 min.	13.7 min.	16.2 min.	24.5 min.	24.5 min.	58.8 min.	100 min.	100 min.	
	Attraction time	ms	50 max.	50 max.	80 max.	100 max.	100 max.	110 max.	80 max.	80 max.	150 max.	300 max.	300 max.	
	Release time	ms	15 max. *5	15 max. *5	70 max. *6	50 max. *6	50 max. *6	50 max. *6	25 max. *5	25 max. *5	50 max. *5	140 max. *7	140 max. *7	
	Backlash		±1°											
	Allowable work per braking	J	392	392	588	1,176	1,176	1,470	1,372	1,372	1,372	2,000	2,000	
	Allowable total work	J	4.9×10 ⁵	4.9×10 ⁵	7.8×10 ⁵	1.5×10 ⁶	1.5×10 ⁶	2.2×10 ⁶	2.9×10 ⁶	2.9×10 ⁶	2.9×10 ⁶	4.0×10 ⁶	4.0×10 ⁶	
	Allowable angular acceleration	rad/s ²	10,000									5,000	3,000	
	Brake limit	—	10 million times min.											
	Rating	—	Continuous											
Insulation class	—	Type F												

*1. These are the values when the motor is combined with a driver at normal temperature (20°C, 65%). The momentary maximum torque indicates the standard value.

*2. Applicable load inertia.

- The operable load inertia ratio (load inertia/rotor inertia) depends on the mechanical configuration and its rigidity. For a machine with high rigidity, operation is possible even with high load inertia. Select an appropriate motor and confirm that operation is possible.
- If the dynamic brake is activated frequently with high load inertia, the Dynamic Brake Resistor may burn. Do not repeatedly turn the servo ON/OFF while the dynamic brake is enabled.
- The dynamic brake is designed only for emergency stops. Design the system so that the Servomotor remains stopped for at least 10 minutes after applying the dynamic brake. Otherwise the dynamic brake circuits may fail.

*3. The allowable radial and thrust loads are the values determined for a limit of 20,000 hours at normal operating temperatures. The allowable radial loads are applied as shown in the following diagram.

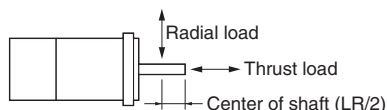

*4. This is a non-excitation brake. (It is released when excitation voltage is applied.)

*5. Direct current switching with a varistor (Z15D151 by Ishizuka Electronics Co.).

*6. Direct current switching with a varistor (TNR9G820K by Nippon Chemi-Con Corporation).

*7. Direct current switching with a varistor (NVD07SCD082 by KOA SPEER ELECTRONICS, INC.).

Torque and Rotation Speed Characteristics

1,500 r/min, 2,000 r/min Servomotors (400 VAC Input Power)

The following graphs show the characteristics with a 3 m standard cable and a 400 VAC input.

- R88M-K40020F/C (400W)

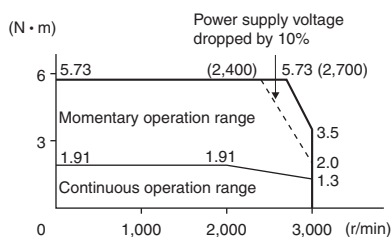

- R88M-K60020F/C (600W)

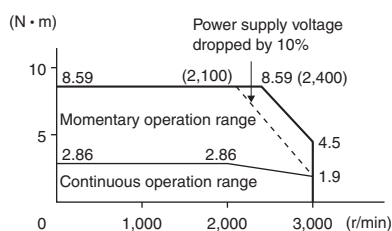

- R88M-K1K020F/C (1kW)

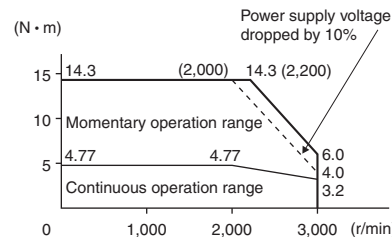

- R88M-K1K520F/C (1.5kW)

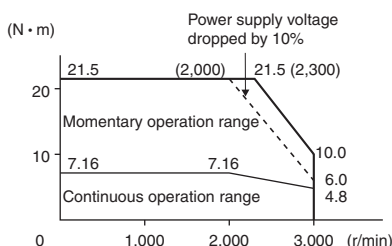

- R88M-K2K020F/C (2kW)

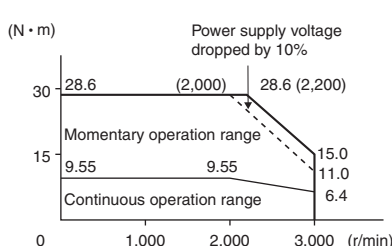

- R88M-K3K020F/C (3kW)

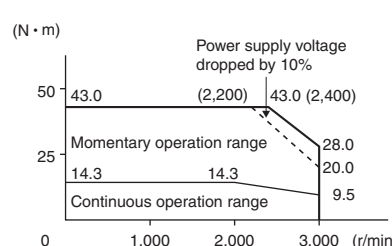

- R88M-K4K020F/C (4kW)

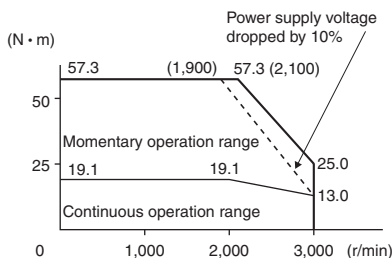

- R88M-K5K020F/C (5kW)

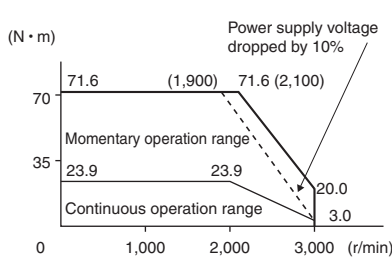

- R88M-K7K515C (7.5kW)

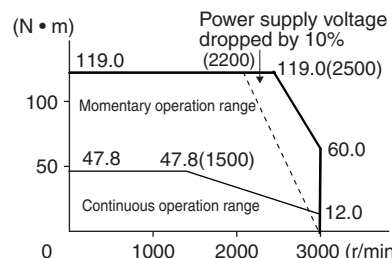

- R88M-K11K015C (11kW)

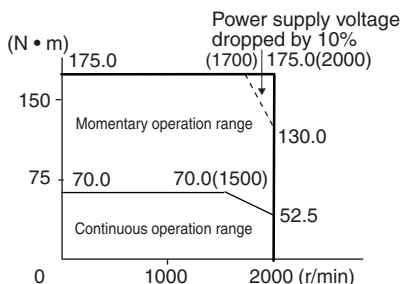

- R88M-K15K015C (15kW)

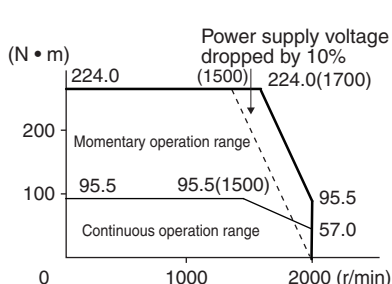

Note 1: The continuous operation range is the range in which continuous operation is possible. Continuous operation at the maximum speed is also possible. However, doing so will reduce the output torque.

Note 2: If the motor power cable exceeds 20 m, the voltage drop will increase and the momentary operation range will become narrower.

AC Servomotor/Drive G5-series

Characteristics

1,000 r/min Servomotors (200/400 VAC Input Power)

Model (R88M-)		200 VAC					400 VAC					
		K90010H	K2K010H	K3K010H	–	–	K90010F	K2K010F	K3K010F	–	–	
Item	Unit	K90010T	K2K010T	K3K010T	K4K510T	K6K010T	K90010C	K2K010C	K3K010C	K4K510C	K6K010C	
Rated output *1	W	900	2,000	3,000	4,500	6,000	900	2,000	3,000	4,500	6,000	
Rated torque *1	N • m	8.59	19.1	28.7	43.0	57.0	8.59	19.1	28.7	43.0	57.3	
Rated rotation speed	r/min	1,000										
Momentary maximum rotation speed	r/min	2,000										
Momentary maximum torque *1	N • m	19.3	47.7	71.7	107.0	143.0	19.3	47.7	71.7	107.0	143.0	
Rated current *1	A (rms)	7.6	17.0	22.6	29.7	38.8	3.8	8.5	11.3	14.8	19.4	
Momentary maximum current *1	A (0-p)	24	60	80	110	149	12	30	40	55	74	
Rotor inertia	Without brake	kW/s	6.70×10 ⁻⁴	30.3×10 ⁻⁴	48.4×10 ⁻⁴	79.1×10 ⁻⁴	101×10 ⁻⁴	6.70×10 ⁻⁴	30.3×10 ⁻⁴	48.4×10 ⁻⁴	79.1×10 ⁻⁴	101×10 ⁻⁴
	With brake	kW/s	7.99×10 ⁻⁴	31.4×10 ⁻⁴	49.2×10 ⁻⁴	84.4×10 ⁻⁴	107×10 ⁻⁴	7.99×10 ⁻⁴	31.4×10 ⁻⁴	49.2×10 ⁻⁴	84.4×10 ⁻⁴	107×10 ⁻⁴
Applicable load inertia	–	10 times the rotor inertia max. *2										
Torque constant *1	N • m/A	0.86	0.88	0.96	1.02	1.04	1.72	1.76	1.92	2.05	2.08	
Power rate *1	Without brake	kW/s	110	120	170	233	325	110	120	170	233	325
	With brake	kW/s	92.4	116	167	219	307	92.4	116	167	219	307
Mechanical time constant	Without brake	ms	0.66	0.75	0.63	0.55	0.54	0.66	0.76	0.61	0.55	0.54
	With brake	ms	0.78	0.78	0.64	0.63	0.57	0.79	0.78	0.62	0.63	0.57
Electrical time constant	ms	11	18	21	20	23	11	18	22	20	23	
Allowable radial load *3	N	686	1176	1470	1470	1764	686	1176	1470	1470	1764	
Allowable thrust load *3	N	196	490	490	490	588	196	490	490	490	588	
Weight	Without brake	kg	Approx. 6.7	Approx. 14.0	Approx. 20.0	Approx. 29.4	Approx. 36.4	Approx. 6.7	Approx. 14.0	Approx. 20.0	Approx. 29.4	Approx. 36.4
	With brake	kg	Approx. 8.2	Approx. 17.5	Approx. 23.5	Approx. 33.3	Approx. 40.4	Approx. 8.2	Approx. 17.5	Approx. 23.5	Approx. 33.3	Approx. 40.4
Radiator plate dimensions (material)		270×260×115 (Al)			470×440×t30 (Al)	550×520×t30 (Al)	270×260×t15 (Al)	470×440×t30 (Al)			550×520×t30 (Al)	
Applicable drives (R88D-)		KT15H/ KN15H- ML2/ KN15H- ECT	KT30H/ KN30H- ML2/ KN30HF- ECT	KT50H/ KN50H- ML2/ KN50H- ECT	KT50H/ KN50H- ECT	KT75H/ KN75H- ECT	KT15F/ KN15F- ML2/ KN15F- ECT	KT30F/ KN30F- ML2/ KN30F- ECT	KT50F/ KN50F- ML2/ KN50F- ECT	KT50F/ KN50F- ECT	KT75F/ KN75F- ECT	
Brake specifications	Brake inertia	kg • m ²	1.35×10 ⁻⁴	4.7×10 ⁻⁴	4.7×10 ⁻⁴	4.7×10 ⁻⁴	4.7×10 ⁻⁴	1.35×10 ⁻⁴	4.7×10 ⁻⁴	4.7×10 ⁻⁴	4.7×10 ⁻⁴	4.7×10 ⁻⁴
	Excitation voltage *4	V	24 VDC±10%									
	Power consumption (at 20°C)	W	19	31	34	34	34	19	31	34	34	34
	Current consumption (at 20°C)	A	0.79±10%	1.3±10%	1.4±10%	1.4±10%	1.4±10%	0.79±10%	1.3±10%	1.4±10%	1.4±10%	1.4±10%
	Static friction torque	N • m	13.7 min.	24.5 min.	58.8 min.	58.8 min.	58.8 min.	13.7 min.	24.5 min.	58.8 min.	58.8 min.	58.8 min.
	Attraction time	ms	100 max.	80 max.	150 max.	150 max.	150 max.	100 max.	80 max.	150 max.	150 max.	150 max.
	Release time	ms	50 max. *5	25 max. *6	50 max. *6	50 max. *6	50 max. *6	50 max. *5	25 max. *6	50 max. *6	50 max. *6	50 max. *6
	Backlash		±1°									
	Allowable work per braking	J	1,176	1,372	1,372	1,372	1,372	1,176	1,372	1,372	1,372	1,372
	Allowable total work	J	1.5×10 ⁶	2.9×10 ⁶	2.9×10 ⁶	2.9×10 ⁶	2.9×10 ⁶	1.5×10 ⁶	2.9×10 ⁶	2.9×10 ⁶	2.9×10 ⁶	2.9×10 ⁶
	Allowable angular acceleration	rad/s ²	10,000			5,000		10,000			5,000	
	Brake limit	–	10 million times min.									
Rating	–	Continuous										
Insulation class	–	Type F										

*1. These are the values when the motor is combined with a driver at normal temperature (20°C, 65%). The momentary maximum torque indicates the standard value.

*2. Applicable load inertia.

- The operable load inertia ratio (load inertia/rotor inertia) depends on the mechanical configuration and its rigidity. For a machine with high rigidity, operation is possible even with high load inertia. Select an appropriate motor and confirm that operation is possible.
- If the dynamic brake is activated frequently with high load inertia, the Dynamic Brake Resistor may burn. Do not repeatedly turn the servo ON/OFF while the dynamic brake is enabled.
- The dynamic brake is designed only for emergency stops. Design the system so that the Servomotor remains stopped for at least 10 minutes after applying the dynamic brake. Otherwise the dynamic brake circuits may fail.

*3. The allowable radial and thrust loads are the values determined for a limit of 20,000 hours at normal operating temperatures. The allowable radial loads are applied as shown in the following diagram.

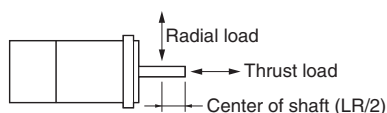

*4. This is a non-excitation brake. (It is released when excitation voltage is applied.)

*5. Direct current switching with a varistor (TNR9G820K by Nippon Chemi-Con Corporation).

*6. Direct current switching with a varistor (Z15D151 by Ishizuka Electronics Co.).

Torque and Rotation Speed Characteristics 1,000 r/min Servomotors (200/400 VAC Input Power)

The following graphs show the characteristics with a 3 m standard cable and a 200 VAC input.

- R88M-K90010H/T/F/C (900W)

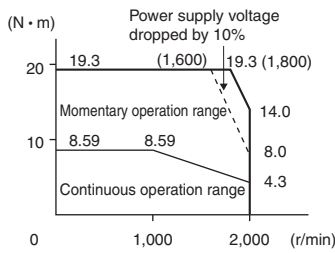

- R88M-K2K010H/T/F/C (2kW)

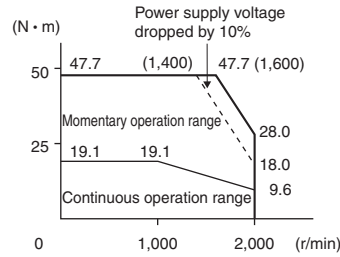

- R88M-K3K010H/T/F/C (3kW)

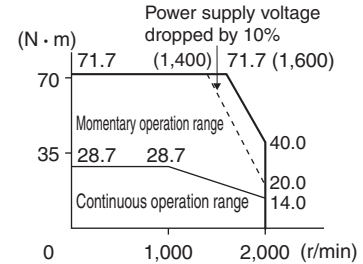

- R88M-K4K510T/C (4.5kW)

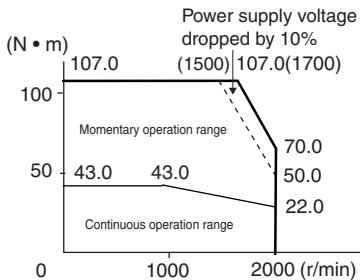

- R88M-K6K010T/C (6kW)

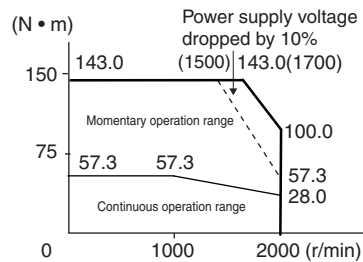

Note 1: The continuous operation range is the range in which continuous operation is possible. Continuous operation at the maximum speed is also possible. However, doing so will reduce the output torque.

Note 2: If the motor power cable exceeds 20 m, the voltage drop will increase and the momentary operation range will become narrower.

Encoder Specifications

Incremental Encoders

Item	Specifications
Encoder system	Optical encoder 20 bits
No. of output pulses	Phases A and B: 262,144 pulses/rotation Phase Z: 1 pulse/rotation
Power supply voltage	5 VDC±5%
Power supply current	180 mA (max.)
Output signals	+S, -S
Output interface	RS-485 compliance

Absolute Encoders

Item	Specifications
Encoder system	Optical encoder 17 bits
No. of output pulses	Phases A and B: 32,768 pulses/rotation Phase Z: 1 pulse/rotation
Maximum rotations	-32,768 to +32,767 rotations
Power supply voltage	5 VDC±5%
Power supply current	150 mA (max.)
Applicable battery voltage	3.6 VDC
Current consumption of battery	265 μA for a maximum of 5 s right after power interruption 100 μA for operation during power interruption 3.6 μA when power is supplied to Servo Drive
Output signals	+S, -S
Output interface	RS-485 compliance

Note: Multi-rotation Data Backup

- The multi-rotation data will be lost if the battery cable connector is disconnected at the motor when connecting the battery cable for the absolute encoder and battery.
- The multi-rotation data will be lost if CN2 is disconnected when connecting the battery to CN1 without the use of a battery cable for the absolute encoder.

AC Servomotor/Drive G5-series

Dimensions

<Cylinder type>

3,000 r/min Servomotors (100/200 VAC)

50W/100W

• Without brake

- R88M-K05030H (-S2)/-K10030□ (-S2) **INC**
- R88M-K05030T (-S2)/-K10030□ (-S2) **ABS**

Model	Dimensions (mm)		
	LL	LM	LN
R88M-K05030□	72	48	23
R88M-K10030□	92	68	43

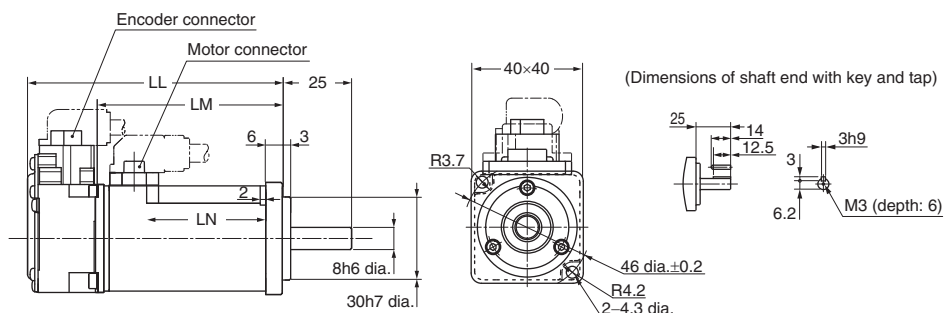

• With brake

- R88M-K05030H-B (S2)/-K10030□-B (S2) **INC**
- R88M-K05030T-B (S2)/-K10030□-B (S2) **ABS**

Model	Dimensions (mm)		
	LL	LM	LN
R88M-K05030□-B□	102	78	23
R88M-K10030□-B□	122	98	43

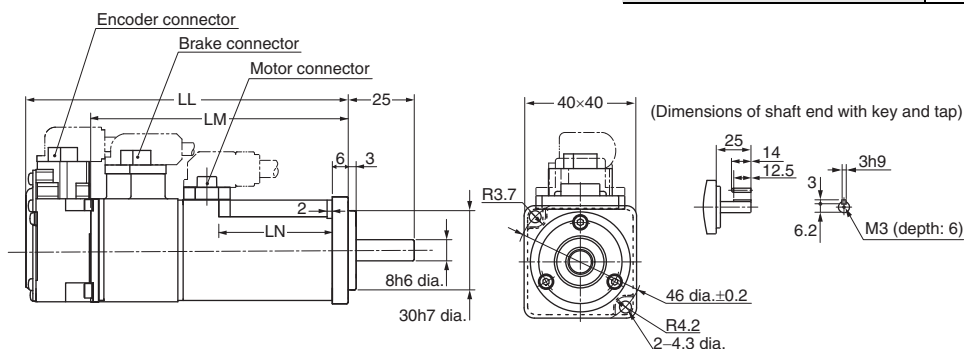

200W/400W

• Without brake

- R88M-K20030□ (-S2)/-K40030□ (-S2) **INC**
- R88M-K20030□ (-S2)/-K40030□ (-S2) **ABS**

Model	Dimensions (mm)		
	LL	LM	LN
R88M-K20030□	79.5	56.5	11
R88M-K40030□	99	76	14

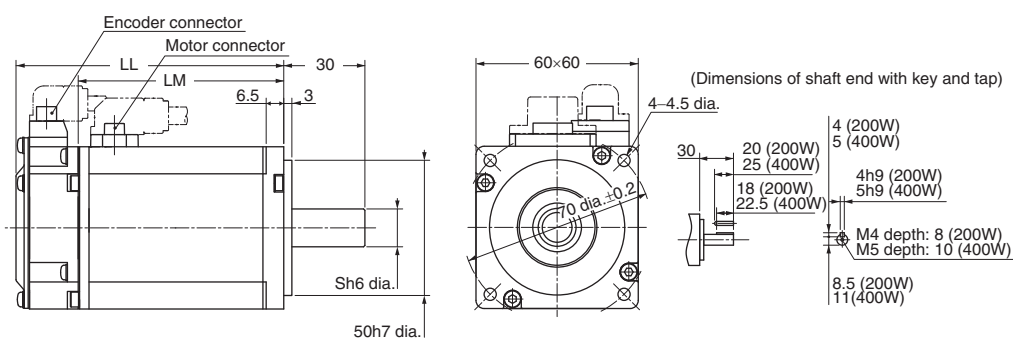

Note: The standard models have a straight shaft. A model with a key and tap is indicated by adding "S2" to the end of the model number. Models with an oil seal are indicated with O at the end of the model number. The motor dimensions do not change.

• **With brake**

- R88M-K20030□-B (S2)/-K40030□-B (S2) **INC**
- R88M-K20030□-B (S2)/-K40030□-B (S2) **ABS**

Model	Dimensions (mm)		
	LL	LM	S
R88M-K20030□-B□	116	93	11
R88M-K40030□-B□	135.5	112.5	14

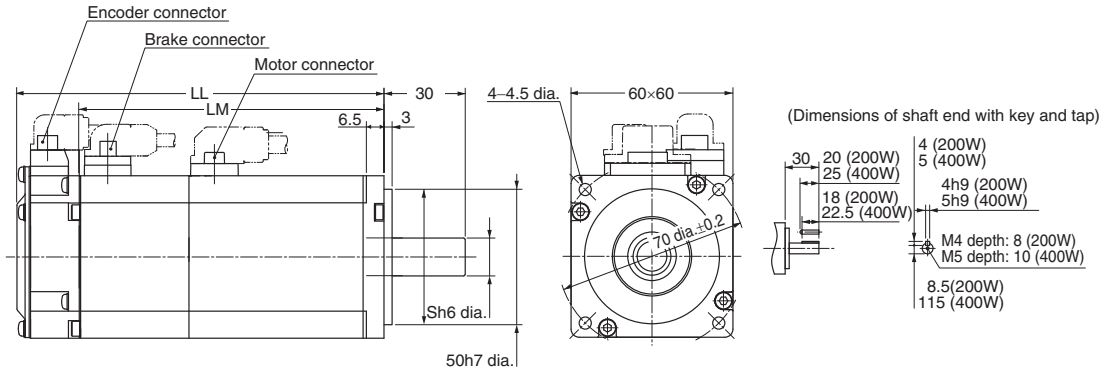

750W

• **Without brake**

- R88M-K75030H (-S2) **INC**
- R88M-K75030T (-S2) **ABS**

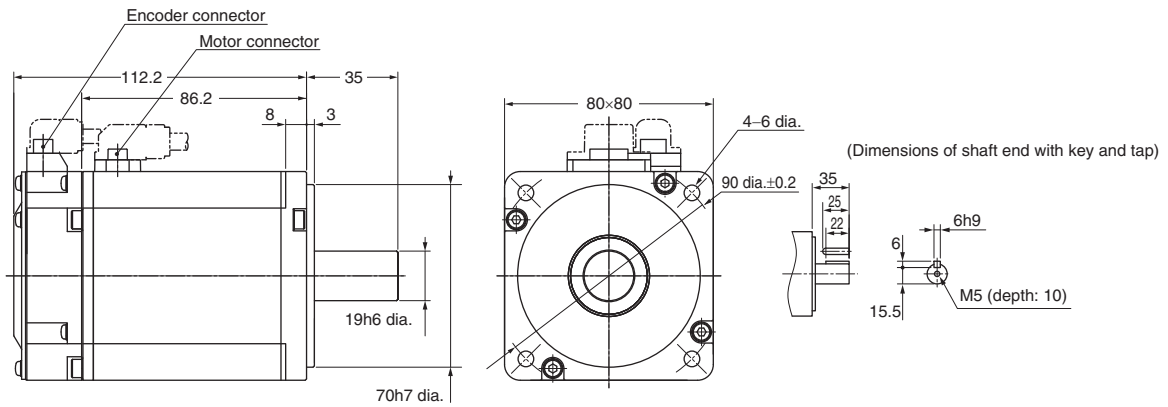

• **With brake**

- R88M-K75030H-B (S2) **INC**
- R88M-K75030T-B (S2) **ABS**

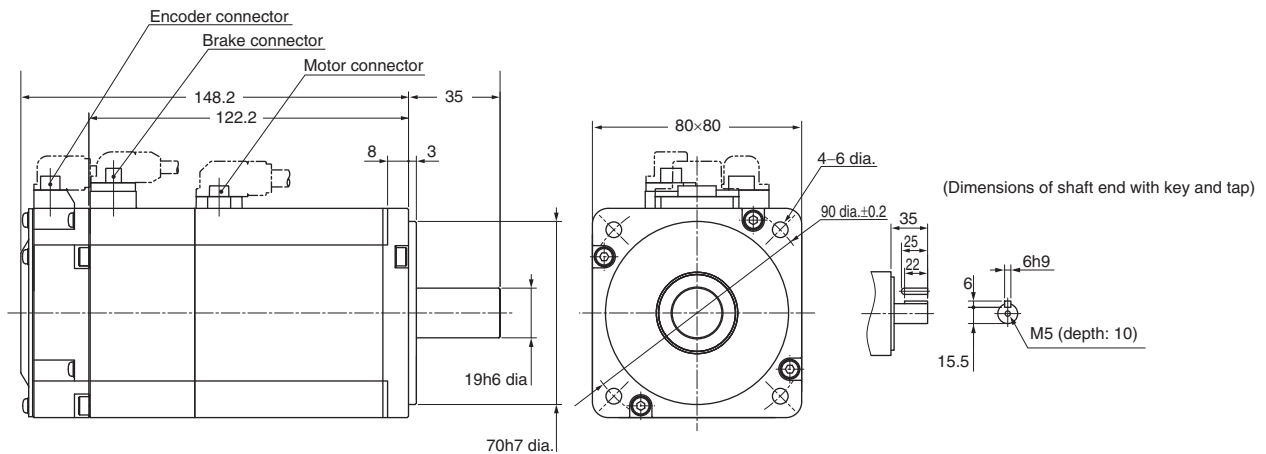

Note: The standard models have a straight shaft. A model with a key and tap is indicated by adding "S2" to the end of the model number. Models with an oil seal are indicated with O at the end of the model number. The motor dimensions do not change.

G5-Series
System Configuration

EtherCAT Communications
AC Servo Drive

EtherCAT Communications
Linear Motor Type
AC Servo Drive

General-purpose Inputs
AC Servo Drive

ML-II Type
AC Servo Drive

AC Servomotors

Linear Motor

Decelerator

AC Servomotor/Drive G5-series

1kW/1.5kW/2kW

• Without brake

- R88M-K1K030H (-S2)/-K1K530H (-S2)/-K2K030H (-S2) **INC**
- R88M-K1K030T (-S2)/-K1K530T (-S2)/-K2K030T (-S2) **ABS**

• With brake

- R88M-K1K030H-B (S2)/-K1K530H-B (S2)/-K2K030H-B (S2) **INC**
- R88M-K1K030T-B (S2)/-K1K530T-B (S2)/-K2K030T-B (S2) **ABS**

Model	Dimensions (mm)			
	LL	LM	KB1	KB2
R88M-K1K030□	141	97	66	119
R88M-K1K530□	159.5	115.5	84.5	137.5
R88M-K2K030□	178.5	134.5	103.5	156.5
R88M-K1K030□-B□	168	124	66	146
R88M-K1K530□-B□	186.5	142.5	84.5	164.5
R88M-K2K030□-B□	205.5	161.5	103.5	183.5

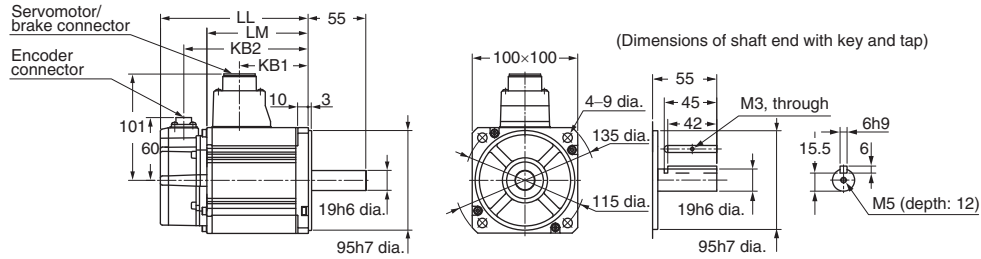

3kW

• Without brake

- R88M-K3K030H (-S2) **INC**
- R88M-K3K030T (-S2) **ABS**

• With brake

- R88M-K3K030H-B (S2) **INC**
- R88M-K3K030T-B (S2) **ABS**

Model	Dimensions (mm)		
	LL	LM	KB2
R88M-K3K030□	190	146	168
R88M-K3K030□-B□	215	171	193

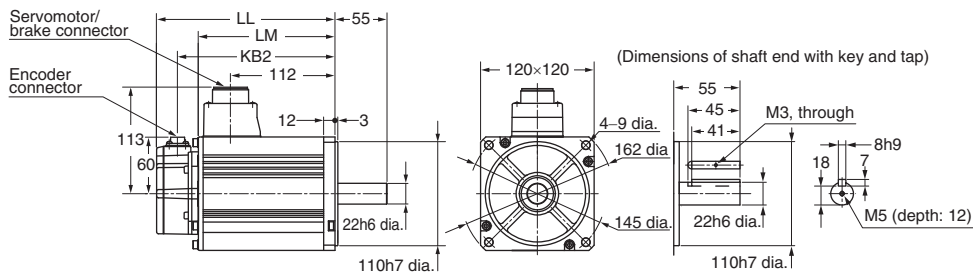

4kW/5kW

• Without brake

- R88M-K4K030H (-S2)/-K5K030H (-S2) **INC**
- R88M-K4K030T (-S2)/-K5K030T (-S2) **ABS**

• With brake

- R88M-K4K030H-B (S2)/-K5K030H-B (S2) **INC**
- R88M-K4K030T-B (S2)/-K5K030T-B (S2) **ABS**

Model	Dimensions (mm)			
	LL	LM	KB1	KB2
R88M-K4K030□	208	164	127	186
R88M-K5K030□	243	199	162	221
R88M-K4K030□-B□	236	192	127	214
R88M-K5K030□-B□	271	227	162	249

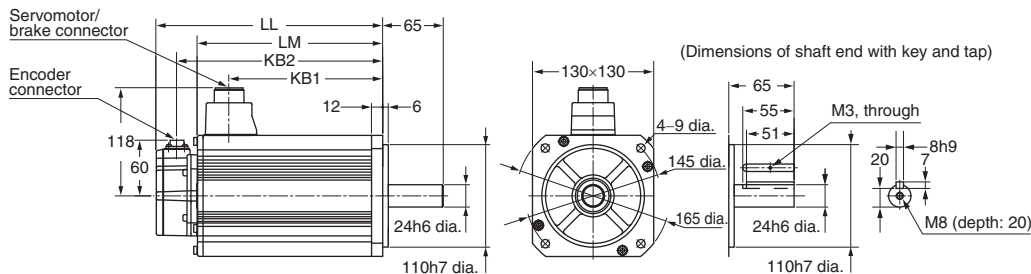

Note: The standard models have a straight shaft. A model with a key and tap is indicated by adding "S2" to the end of the model number. Models with an oil seal are indicated with O at the end of the model number. The motor dimensions do not change.

3,000 r/min Servomotors (400 VAC)

750W/1kW/1.5kW/2kW

• Without brake

- R88M-K75030F (-S2)/-K1K030F (-S2)/-K1K530F (-S2)/-K2K030F (-S2) **INC**
- R88M-K75030C (-S2)/-K1K030C (-S2)/-K1K530C (-S2)/-K2K030C (-S2) **ABS**

• With brake

- R88M-K75030F-B (S2)/-K1K030F-B (S2)/-K1K530F-B (S2)/-K2K030F-B (S2) **INC**
- R88M-K75030C-B (S2)/-K1K030C-B (S2)/-K1K530C-B (S2)/-K2K030C-B (S2) **ABS**

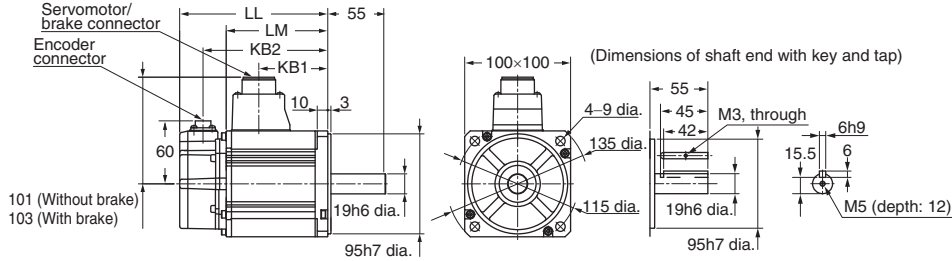

Model	Dimensions (mm)			
	LL	LM	KB1	KB2
R88M-K75030□	131.5	87.5	56.5	109.5
R88M-K1K030□	141	97	66	119
R88M-K1K530□	159.5	115.5	84.5	137.5
R88M-K2K030□	178.5	134.5	103.5	156.5
R88M-K75030□-B□	158.5	114.5	53.5	136.5
R88M-K1K030□-B□	168	124	63	146
R88M-K1K530□-B□	186.5	142.5	81.5	164.5
R88M-K2K030□-B□	205.5	161.5	100.5	183.5

3kW

• Without brake

- R88M-K3K030F (-S2) **INC**
- R88M-K3K030C (-S2) **ABS**

• With brake

- R88M-K3K030F-B (S2) **INC**
- R88M-K3K030C-B (S2) **ABS**

Model	Dimensions (mm)		
	LL	LM	KB2
R88M-K3K030□	190	146	168
R88M-K3K030□-B□	215	171	193

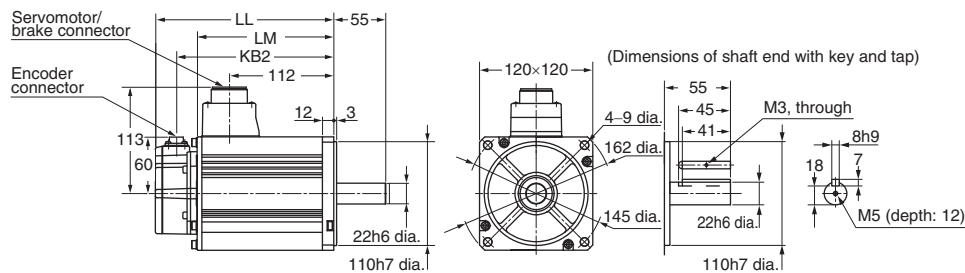

Note: The standard models have a straight shaft. A model with a key and tap is indicated by adding "S2" to the end of the model number. Models with an oil seal are indicated with O at the end of the model number. The motor dimensions do not change.

AC Servomotor/Drive G5-series

4kW/5kW

• Without brake

- R88M-K4K030F (-S2)/-K5K030F (-S2) **INC**
- R88M-K4K030C (-S2)/-K5K030C (-S2) **ABS**

• With brake

- R88M-K4K030F-B (S2)/-K5K030F-B (S2) **INC**
- R88M-K4K030C-B (S2)/-K5K030C-B (S2) **ABS**

Model	Dimensions (mm)			
	LL	LM	KB1	KB2
R88M-K4K030□	208	164	127	186
R88M-K5K030□	243	199	162	221
R88M-K4K030□-B□	236	192	127	214
R88M-K5K030□-B□	271	227	162	249

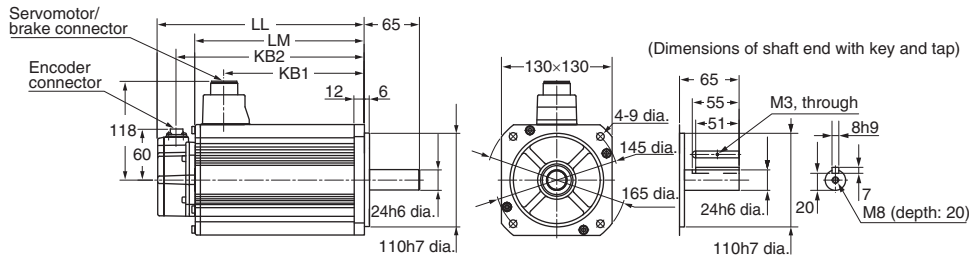

Note: The standard models have a straight shaft. A model with a key and tap is indicated by adding "S2" to the end of the model number. Models with an oil seal are indicated with O at the end of the model number. The motor dimensions do not change.

1,500r/min, 2,000 r/min Servomotors (200 VAC)

1kW/1.5kW/2kW/3kW

• Without brake

- R88M-K1K020H (-S2)/-K1K520H (-S2)/-K2K020H (-S2)/-K3K020H (-S2) **INC**
- R88M-K1K020T (-S2)/-K1K520T (-S2)/-K2K020T (-S2)/-K3K020T (-S2) **ABS**

• With brake

- R88M-K1K020H-B (S2)/-K1K520H-B (S2)/-K2K020H-B (S2)/-K3K020H-B (S2) **INC**
- R88M-K1K020T-B (S2)/-K1K520T-B (S2)/-K2K020T-B (S2)/-K3K020T-B (S2) **ABS**

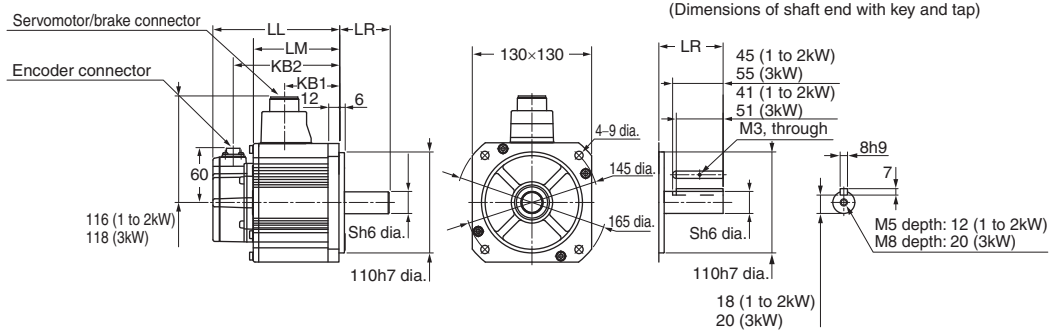

Model	Dimensions (mm)					
	LL	LR	LM	S	KB1	KB2
R88M-K1K020□	138	55	94	22	60	116
R88M-K1K520□	155.5	55	111.5	22	77.5	133.5
R88M-K2K020□	173	55	129	22	95	151
R88M-K3K020□	208	65	164	24	127	186
R88M-K1K020□-B□	166	55	122	22	60	144
R88M-K1K520□-B□	183.5	55	139.5	22	77.5	161.5
R88M-K2K020□-B□	201	55	157	22	95	179
R88M-K3K020□-B□	236	65	192	24	127	214

4kW/5kW

• Without brake

- R88M-K4K020H (-S2)/-K5K020H (-S2) **INC**
- R88M-K4K020T (-S2)/-K5K020T (-S2) **ABS**

• With brake

- R88M-K4K020H-B (S2)/-K5K020H-B (S2) **INC**
- R88M-K4K020T-B (S2)/-K5K020T-B (S2) **ABS**

Model	Dimensions (mm)			
	LL	LM	KB1	KB2
R88M-K4K020□	177	133	96	155
R88M-K5K020□	196	152	115	174
R88M-K4K020□-B□	206	162	96	184
R88M-K5K020□-B□	225	181	115	203

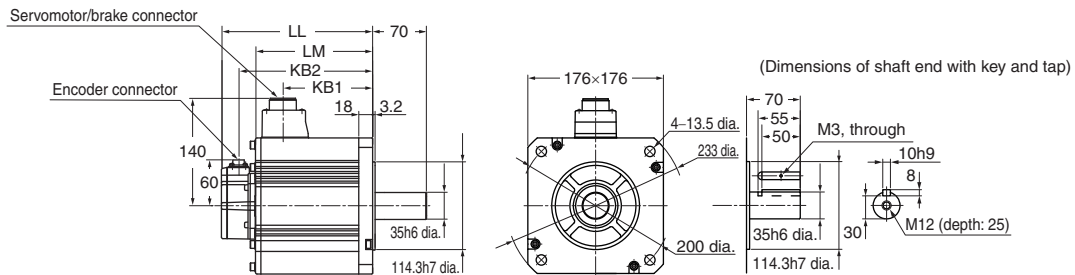

Note: The standard models have a straight shaft. A model with a key and tap is indicated by adding "S2" to the end of the model number. Models with an oil seal are indicated with O at the end of the model number. The motor dimensions do not change.

AC Servomotor/Drive G5-series

7.5kW

• Without brake

- R88M-K7K515T (-S2) **ABS**

• With brake

- R88M-K7K515T-B (S2) **ABS**

Model	Dimensions (mm)								
	LL	LR	LM	S	KB1	KB2	L1	L2	L3
R88M-K7K515T□	312	113	268	42	219	290	117.5	117.5	149
R88M-K7K515T-B□	337	113	293	42	253	315	117.5	152.5	183

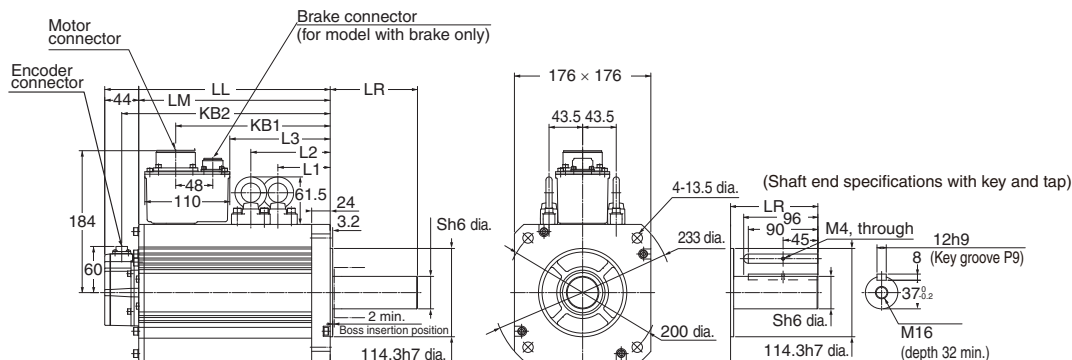

11kW/15kW

• Without brake

- R88M-K11K015T (-S2)/-K15K015T (-S2) **ABS**

• With brake

- R88M-K11K015T-B (S2)/R88M-K15K015T-B (S2) **ABS**

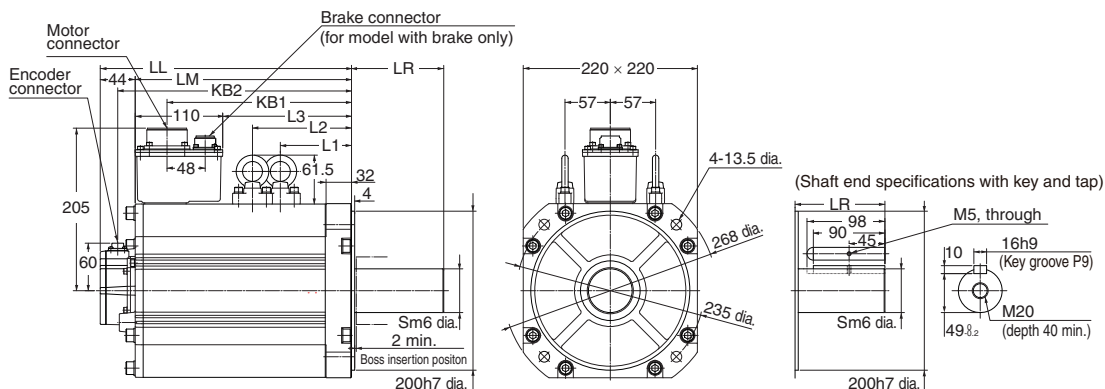

Model	Dimensions (mm)								
	LL	LR	LM	S	KB1	KB2	L1	L2	L3
R88M-K11K015T□	316	116	272	55	232	294	124.5	124.5	162
R88M-K15K015T□	384	116	340	55	300	362	158.5	158.5	230
R88M-K11K015T-B□	364	116	320	55	266	342	124.5	159.5	196
R88M-K15K015T-B□	432	116	388	55	334	410	158.5	193.5	264

Note: The standard models have a straight shaft. A model with a key and tap is indicated by adding "S2" to the end of the model number. Models with an oil seal are indicated with O at the end of the model number. The motor dimensions do not change.

1,500 r/min, 2,000 r/min Servomotors (400 VAC)

400W/600W

• Without brake

- R88M-K40020F (-S2)/-K60020F (-S2) **INC**
- R88M-K40020C (-S2)/-K60020C (-S2) **ABS**

• With brake

- R88M-K40020F-B (S2)/-K60020F-B (S2) **INC**
- R88M-K40020C-B (S2)/-K60020C-B (S2) **ABS**

Model	Dimensions (mm)			
	LL	LM	KB1	KB2
R88M-K40020□	131.5	87.5	56.5	109.5
R88M-K60020□	141	97	66	119
R88M-K40020□-B□	158.5	114.5	53.5	136.5
R88M-K60020□-B□	168	124	63	146

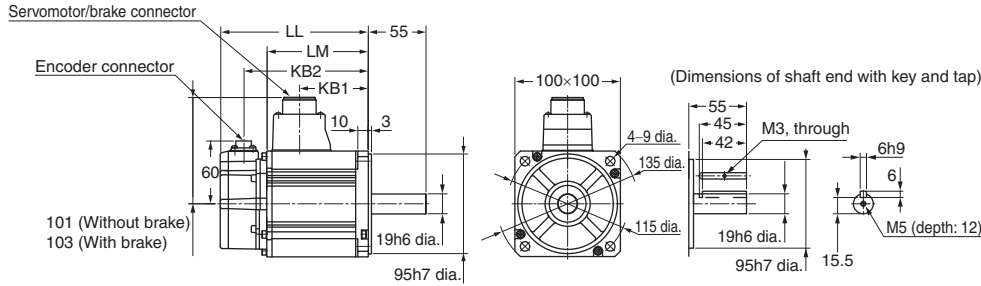

1kW/1.5kW/2kW/3kW

• Without brake

- R88M-K1K020F (-S2)/-K1K520F (-S2)/-K2K020F (-S2)/-K3K020F (-S2) **INC**
- R88M-K1K020C (-S2)/-K1K520C (-S2)/-K2K020C (-S2)/-K3K020C (-S2) **ABS**

• With brake

- R88M-K1K020F-B (S2)/-K1K520F-B (S2)/-K2K020F-B (S2)/-K3K020F-B (S2) **INC**
- R88M-K1K020C-B (S2)/-K1K520C-B (S2)/-K2K020C-B (S2)/-K3K020C-B (S2) **ABS**

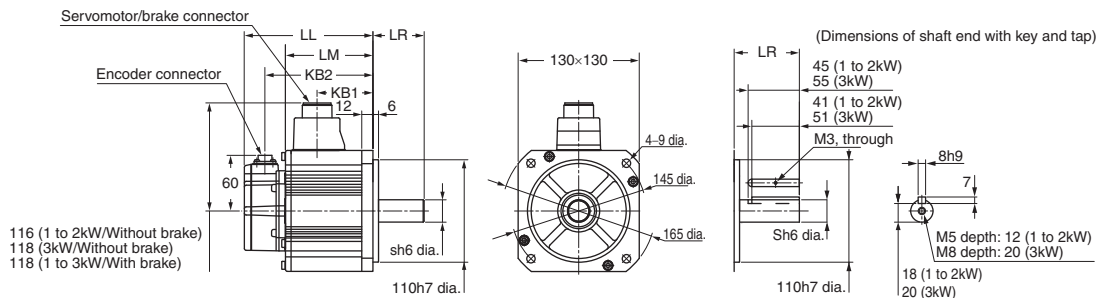

Model	Dimensions (mm)					
	LL	LR	LM	S	KB1	KB2
R88M-K1K020□	138	55	94	22	60	116
R88M-K1K520□	155.5	55	111.5	22	77.5	133.5
R88M-K2K020□	173	55	129	22	95	151
R88M-K3K020□	208	65	164	24	127	186
R88M-K1K020□-B□	166	55	122	22	57	144
R88M-K1K520□-B□	183.5	55	139.5	22	74.5	161.5
R88M-K2K020□-B□	201	55	157	22	92	179
R88M-K3K020□-B□	236	65	192	24	127	214

Note: The standard models have a straight shaft. A model with a key and tap is indicated by adding "S2" to the end of the model number. Models with an oil seal are indicated with O at the end of the model number. The motor dimensions do not change.

G5-Series
System Configuration

EtherCAT Communications
AC Servo Drive

EtherCAT Communications
Linear Motor Type
AC Servo Drive

General-purpose Inputs
AC Servo Drive

ML-II Type
AC Servo Drive

AC Servomotors

Linear Motor

Decelerator

AC Servomotor/Drive G5-series

4kW/5kW

• Without brake

- R88M-K4K020F (-S2)/-K5K020F (-S2) **INC**
- R88M-K4K020C (-S2)/-K5K020C (-S2) **ABS**

• With brake

- R88M-K4K020F-B (S2)/-K5K020F-B (S2) **INC**
- R88M-K4K020C-B (S2)/-K5K020C-B (S2) **ABS**

Model	Dimensions (mm)			
	LL	LM	KB1	KB2
R88M-K4K020□	177	133	96	155
R88M-K5K020□	196	152	115	174
R88M-K4K020□-B□	206	162	96	184
R88M-K5K020□-B□	225	181	115	203

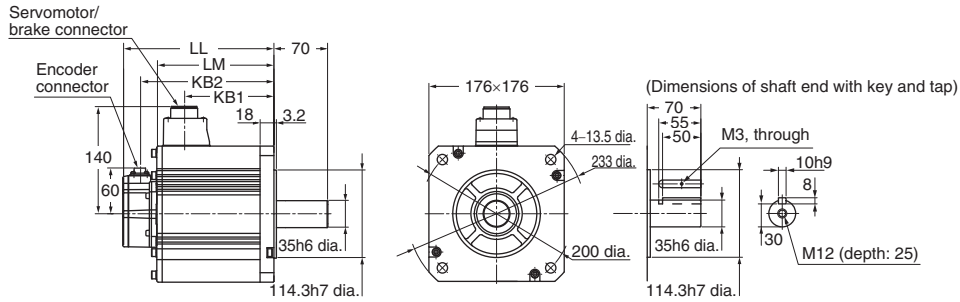

7.5kW

• Without brake

- R88M-K7K515C (-S2) **ABS**

• With brake

- R88M-K7K515C-B (S2) **ABS**

Model	Dimensions (mm)								
	LL	LR	LM	S	KB1	KB2	L1	L2	L3
R88M-K7K515C□	312	133	268	42	219	290	117.5	117.5	149
R88M-K7K515C-B□	337	113	293	42	253	315	117.5	152.5	183

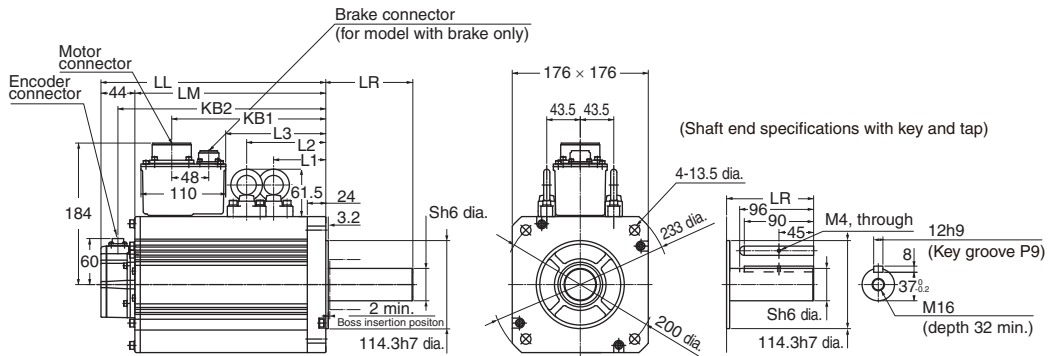

Note: The standard models have a straight shaft. A model with a key and tap is indicated by adding "S2" to the end of the model number. Models with an oil seal are indicated with O at the end of the model number. The motor dimensions do not change.

11kW/15kW

• Without brake

- R88M-K11K015C (-S2)/K15K015C (-S2) **ABS**

• With brake

- R88M-K11K015C-B (S2)/R88M-K15K015C-B (S2) **ABS**

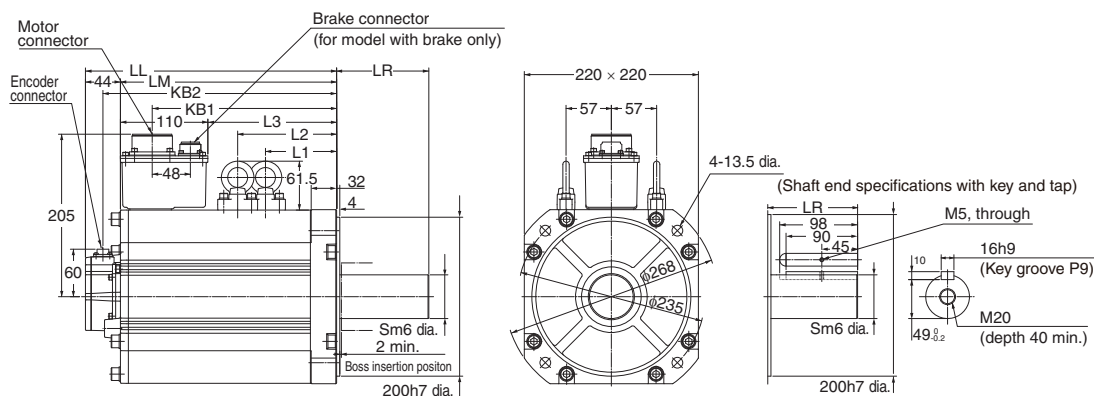

Model	Dimensions (mm)								
	LL	LR	LM	S	KB1	KB2	L1	L2	L3
R88M-K11K015C□	316	116	272	55	232	294	124.5	124.5	162
R88M-K15K015C□	384	116	340	55	300	362	158.5	158.5	230
R88M-K11K015C-B□	364	116	320	55	266	342	124.5	159.5	196
R88M-K15K015C-B□	432	116	388	55	334	410	158.5	193.5	264

Note: The standard models have a straight shaft. A model with a key and tap is indicated by adding "S2" to the end of the model number. Models with an oil seal are indicated with O at the end of the model number. The motor dimensions do not change.

AC Servomotor/Drive G5-series

1,000 r/min Servomotors (200 VAC)

900W

• Without brake

- R88M-K90010H (-S2) **INC**
- R88M-K90010T (-S2) **ABS**

• With brake

- R88M-K90010H-B (S2) **INC**
- R88M-K90010T-B (S2) **ABS**

Model	Dimensions (mm)		
	LL	LM	KB2
R88M-K90010□	155.5	111.5	133.5
R88M-K90010□-B□	183.5	139.5	161.5

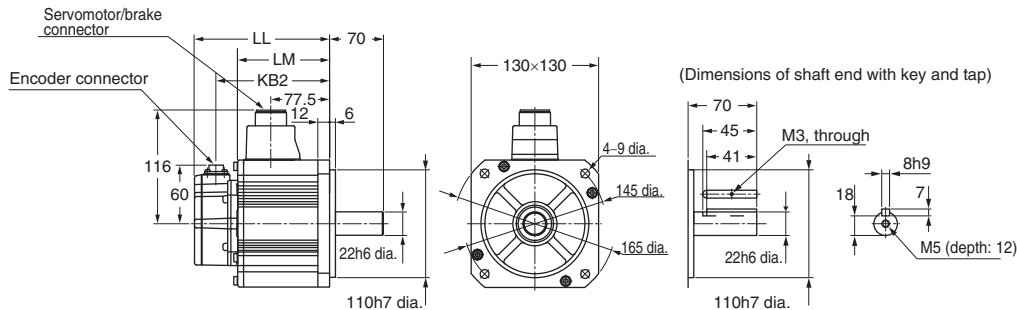

2kW/3kW

• Without brake

- R88M-K2K010H (-S2)/-K3K010H (-S2) **INC**
- R88M-K2K010T (-S2)/-K3K010T (-S2) **ABS**

• With brake

- R88M-K2K010H-B (S2)/-K3K010H-B (S2) **INC**
- R88M-K2K010T-B (S2)/-K3K010T-B (S2) **ABS**

Model	Dimensions (mm)			
	LL	LM	KB1	KB2
R88M-K2K010□	163.5	119.5	82.5	141.5
R88M-K3K010□	209.5	165.5	128.5	187.5
R88M-K2K010□-B□	192.5	148.5	82.5	170.5
R88M-K3K010□-B□	238.5	194.5	128.5	216.5

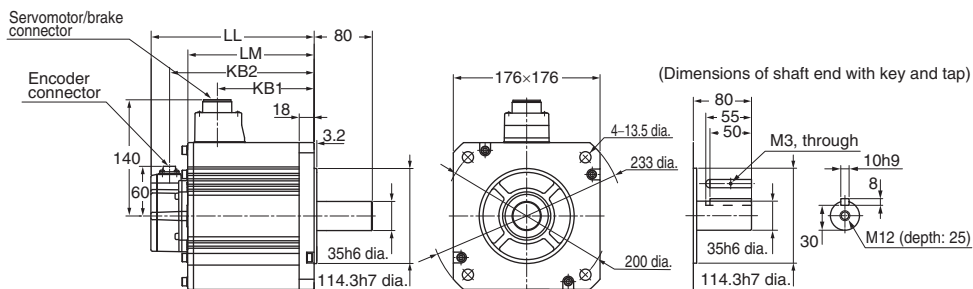

4.5kW

• Without brake

- R88M-K4K510T (-S2) **ABS**

• With brake

- R88M-K4K510T-B (S2) **ABS**

Model	Dimensions (mm)							
	LL	LR	LM	S	KB1	KB2	L1	L2
R88M-K4K510T□	266	113	222	42	185	244	98	98
R88M-K4K510T-B□	291	113	247	42	185	269	98	133

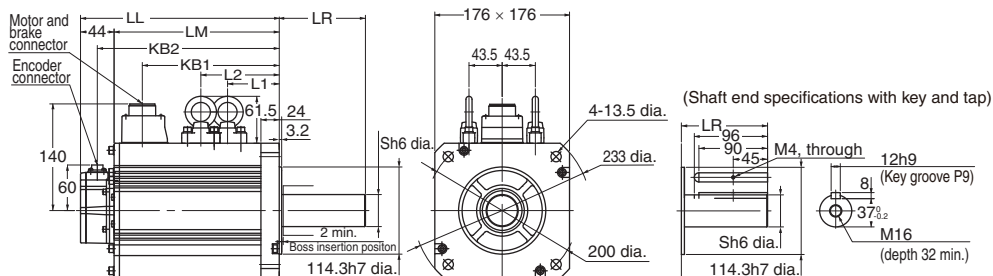

Note: The standard models have a straight shaft. A model with a key and tap is indicated by adding "S2" to the end of the model number. Models with an oil seal are indicated with O at the end of the model number. The motor dimensions do not change.

6kW

• Without brake

- R88M-K6K010T (-S2) **ABS**

• With brake

- R88M-K6K010T-B (S2) **ABS**

Model	Dimensions (mm)								
	LL	LR	LM	S	KB1	KB2	L1	L2	L3
R88M-K6K010T □	312	113	268	42	219	290	117.5	117.5	149
R88M-K6K010T-B □	337	113	293	42	253	315	117.5	152.5	183

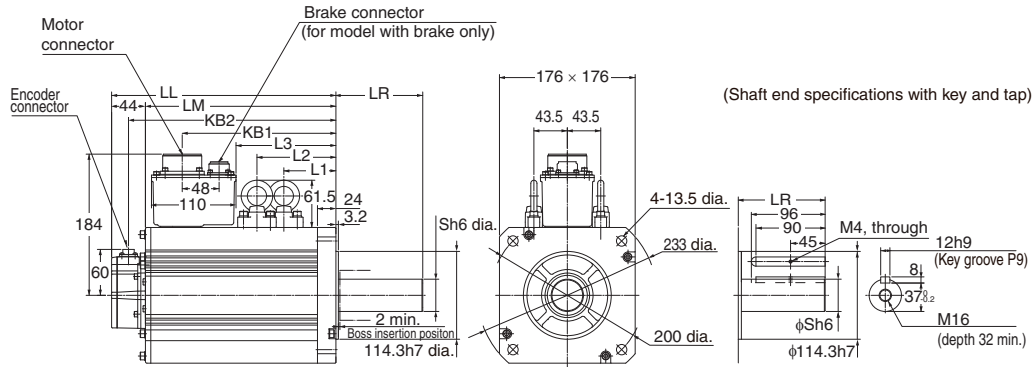

Note: The standard models have a straight shaft. A model with a key and tap is indicated by adding "S2" to the end of the model number. Models with an oil seal are indicated with O at the end of the model number. The motor dimensions do not change.

AC Servomotor/Drive G5-series

1,000 r/min Servomotors (400 VAC)

900W

• Without brake

- R88M-K90010F (-S2) **INC**
- R88M-K90010C (-S2) **ABS**

• With brake

- R88M-K90010F-B (S2) **INC**
- R88M-K90010C-B (S2) **ABS**

Model	Dimensions (mm)			
	LL	LM	KB1	KB2
R88M-K90010□	155.5	111.5	77.5	133.5
R88M-K90010□-B□	183.5	139.5	74.5	161.5

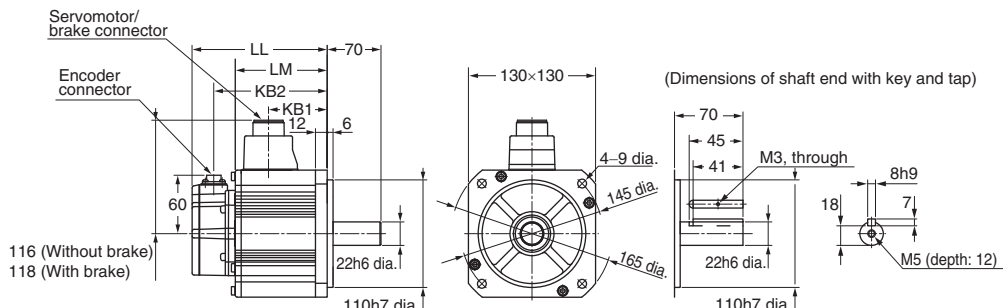

2kW/3kW

• Without brake

- R88M-K2K010F (-S2)/-K3K010F (-S2) **INC**
- R88M-K2K010C (-S2)/-K3K010C (-S2) **ABS**

• With brake

- R88M-K2K010F-B (S2)/-K3K010F-B (S2) **INC**
- R88M-K2K010C-B (S2)/-K3K010C-B (S2) **ABS**

Model	Dimensions (mm)			
	LL	LM	KB1	KB2
R88M-K2K010□	163.5	119.5	82.5	141.5
R88M-K3K010□	209.5	165.5	128.5	187.5
R88M-K2K010□-B□	192.5	148.5	82.5	170.5
R88M-K3K010□-B□	238.5	194.5	128.5	216.5

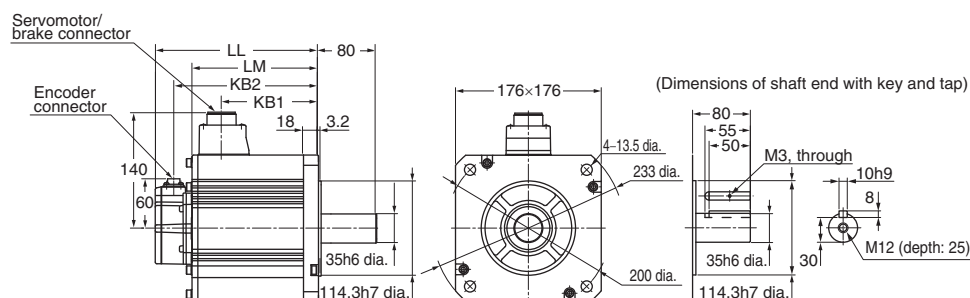

4.5kW

• Without brake

- R88M-K4K510C (-S2) **ABS**

• With brake

- R88M-K4K510C-B (S2) **ABS**

Model	Dimensions (mm)							
	LL	LR	LM	S	KB1	KB2	L1	L2
R88M-K4K510T□	266	113	222	42	185	244	98	98
R88M-K4K510T-B□	291	113	247	42	185	269	98	133

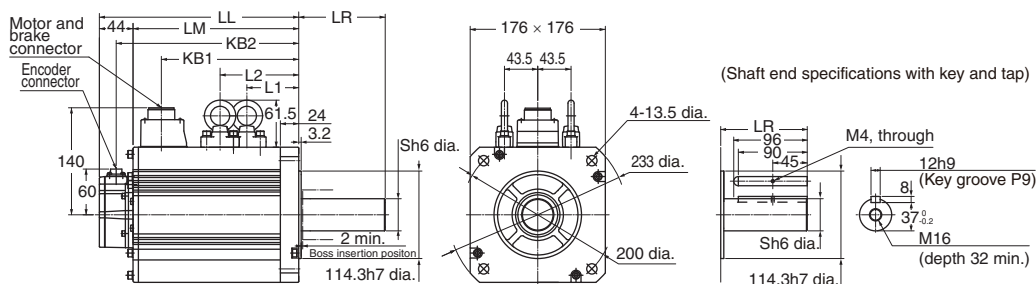

Note: The standard models have a straight shaft. A model with a key and tap is indicated by adding "S2" to the end of the model number. Models with an oil seal are indicated with O at the end of the model number. The motor dimensions do not change.

6kW

• Without brake

- R88M-K6K010C (-S2) **ABS**

• With brake

- R88M-K6K010C-B (S2) **ABS**

Model	Dimensions (mm)								
	LL	LR	LM	S	KB1	KB2	L1	L2	L3
R88M-K6K010C□	312	113	268	42	219	290	117.5	117.5	149
R88M-K6K010C-B□	337	113	293	42	253	315	117.5	152.5	183

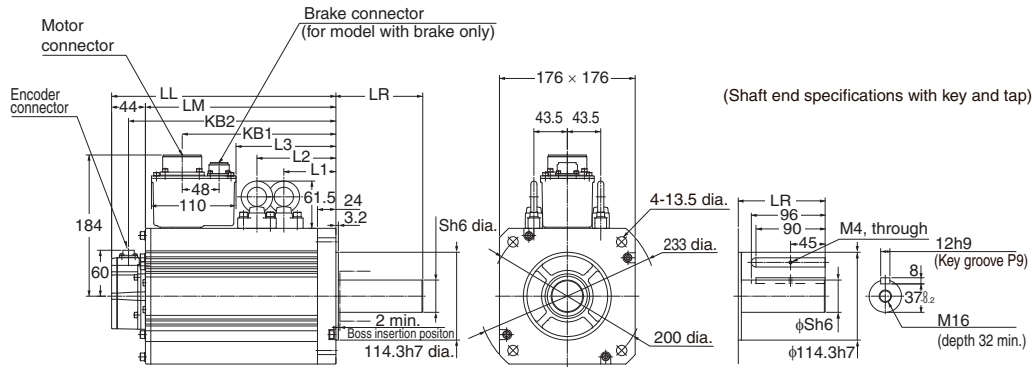

Note: The standard models have a straight shaft. A model with a key and tap is indicated by adding "S2" to the end of the model number. Models with an oil seal are indicated with O at the end of the model number. The motor dimensions do not change.