

## Enclosed Switches

# ZE/ZV/ZV2/XE/XV/XV2

### Long Service Life and Large Breaking Power

- ZE, ZV, and ZV2 incorporate Model Z Basic Switches with rugged diecast cases.
- Available with various models of built-in switches (including split contact model, maintained operation type, magnetic blowout model) and various actuators.
- XE, XV, and XV2 Switches have a built-in X-type magnetic blowout basic switch for DC applications.
- Three mounting methods: Side, base, and diagonal side.
- Easy wiring: Terminals on internal switch are facing forward when the cover is opened.
- Switches with ground terminals have CE marking.
- Approved by UL, CSA, and CCC (Chinese standard).



## Model Number Structure

### Model Number Legend

□□-□-2□  
1 2 3 4

#### 1. Built-in Switch

- Z: SPDT (AC)
- X: SPDT (DC)

#### 2. Mounting Direction

- E: Side mounting
- V: Base mounting
- V2: Diagonal side mounting

#### 3. Actuator

- Q: Plunger
- Q22: Roller plunger
- Q21: Crossroller plunger
- QA2: Roller arm lever
- QA277: One-way action roller arm lever
- N: Sealed plunger
- N22: Sealed roller plunger (ZE, ZV, ZV2 only)
- N21: Sealed crossroller plunger (ZE, ZV, ZV2 only)
- NA2: Sealed roller arm lever
- NA277: Sealed one-way action roller arm lever

#### 4. Conduit/Ground Terminal

- None: G 1/2" without ground terminal
- G1: G 1/2" with ground terminal
- G: Pg13.5 with ground terminal
- SG1: 1/2"-14NPSM with ground terminal
- YG1: M20 with ground terminal
- S: 1/2"-14NPSM without ground terminal
- Y: M20 without ground terminal

# Ordering Information

## List of Models

### Standard Switches

Contact		Actuator	Side mounting		Diagonal side mounting		Base mounting	
			General purpose	Sealed (Booted)	General purpose	Sealed (Booted)	General purpose	Sealed (Booted)
AC/DC load	SPDT	Plunger	ZE-Q-2	ZE-N-2	ZV2-Q-2	ZV2-N-2	ZV-Q-2	ZV-N-2
		Roller plunger	ZE-Q22-2	ZE-N22-2	ZV2-Q22-2	ZV2-N22-2	ZV-Q22-2	ZV-N22-2
		Crossroller plunger	ZE-Q21-2	ZE-N21-2	ZV2-Q21-2	ZV2-N21-2	ZV-Q21-2	ZV-N21-2
		Roller arm lever	ZE-QA2-2	ZE-NA2-2	ZV2-QA2-2	ZV2-NA2-2	ZV-QA2-2	ZV-NA2-2
		One-way action roller arm lever	ZE-QA277-2	ZE-NA277-2	ZV2-QA277-2	ZV2-NA277-2	---	ZV-NA277-2
DC load	SPDT	Plunger	XE-Q-2	XE-N-2	XV2-Q-2	XV2-N-2	XV-Q-2	XV-N-2
		Roller plunger	XE-Q22-2	---	XV2-Q22-2	---	XV-Q22-2	---
		Crossroller plunger	XE-Q21-2	---	---	---	XV-Q21-2	---
		Roller arm lever	XE-QA2-2	XE-NA2-2	XV2-QA2-2	XV2-NA2-2	XV-QA2-2	XV-NA2-2
		One-way action roller arm lever	XE-QA277-2	XE-NA277-2	---	XV2-NA277-2	XV-QA277-2	XV-NA277-2

- Note:**
1. The diagonal side mounting model feature improved sealing property, improved mounting strength through use of M5 screws, increased stability in seating with large mounting width (31 x 75 mm) and permit coupling of a number of Switch units.
  2. ZE, ZV, and ZV2 series are approved by UL, CSA, and CCC.
  3. Ask your OMRON representative for information on models with ground terminals.

## Specifications

### Approved Standards

Agency	Standard	File No.
UL	UL508	E76675
CSA	CSA C22.2 No. 14	LR45746
CCC (CQC)	GB14048.5	2003010303077623

- Note:**
1. Models XE, XV, and XV2 are not approved by UL, CSA, and CCC.
  2. Ask your OMRON representative for information on approved models.

### Approved Standard Ratings

#### UL/CSA

Model	Rated voltage	Current	Horsepower
ZE	125 VAC	15 A	1/8 HP 1/4 HP
	250 VAC		
	480 VAC		
	125 VDC	0.5 A	---
	250 VDC	0.25 A	---

#### CCC (GB14048.5)

Applicable category and ratings
AC-12 10 A/250 VAC

### General Ratings

Contact	Contact	Rated voltage	Non-inductive load				Inductive load			
			Resistive load		Lamp load		Inductive load		Motor load	
			NC	NO	NC	NO	NC	NO	NC	NO
ZE-□ ZV-□ ZV2-□		125 VAC	15 A		3 A	1.5 A	15 A		5 A	2.5 A
		250 VAC	15 A		2.5 A	1.25 A	15 A		3 A	1.5 A
		480 VAC	10 A		1.5 A	0.75 A	6 A		1.5 A	0.75 A
		125 VDC	0.5 A		0.5 A		0.05 A		0.05 A	
		250 VDC	0.25 A		0.25 A		0.03 A		0.03 A	
XE-□ XV-□ XV2-□		8 VDC	10 A		3 A	1.5 A	10 A	10 A	5 A	2.5 A
		14 VDC	10 A		3 A	1.5 A	10 A	10 A	5 A	2.5 A
		30 VDC	10 A		3 A	1.5 A	10 A	10 A	5 A	2.5 A
		125 VDC	10 A		3 A	1.5 A	7.5 A	6 A	2 A	2.5 A
		250 VDC	3 A		1.5 A	0.75 A	2 A	1.5 A	2 A	1.5 A

- Note:**
1. The above figures are for standard currents.
  2. Inductive loads have a power factor of 0.4 min. (AC) and a time constant of 7 ms max. (DC).
  3. Lamp load has an inrush current of 10 times the steady-state current.

4. Motor load has an inrush current of 6 times the steady-state current.

Inrush current	NC	NO
	30 A max.	15 A max.

## ■ Characteristics

Degree of protection	IP65 (see note 2)
Durability (see note 3)	Mechanical: Z□: 10,000,000 operations min. X□: 1,000,000 operations min. Electrical: Z□: 500,000 operations min., for 15 A, 250 VAC resistive load X□: 100,000 operations min., for 10 A, 125 VDC resistive load
Operating speed	Plunger type: 0.01 mm to 0.5 m/s Lever type: 0.02 mm to 0.5 m/s
Operating frequency	Mechanical: 120 operations/min Electrical: 20 operations/min
Rated frequency	50/60 Hz
Insulation resistance	100 MΩ min. (at 500 VDC)
Contact resistance	15 mΩ max. (initial value)
Terminal temperature rise	50°C max.
Dielectric strength	1,000 VAC, 50/60 Hz for 1 min between terminals of the same polarity 2,000 VAC, 50/60 Hz for 1 min between current-carrying metal part and ground, and between each terminal and non-current-carrying metal part (1,500 VAC for Z□ models and X□ models)
Vibration resistance	Malfunction: 10 to 55 Hz, 1.5-mm double amplitude (see note 4)
Shock resistance (see note 4)	Destruction: 1,000 m/s <sup>2</sup> min. Malfunction: 100 m/s <sup>2</sup> min. (see note 5), 50 m/s <sup>2</sup> min. (see note 6)
Ambient temperature (see note 1)	Operating: -10°C to 80°C (with no icing)
Ambient humidity	Operating: General-purpose type: 35% to 85% Sealed type: 35% to 95%
Weight	Approx. 260 to 280 g

- Note:**
1. The above figures are initial values.
  2. IP65 for □-N models and IP60 for □-Q models.
  3. The values are calculated at an operating temperature of 5°C to 35°C, and an operating humidity of 40% to 70%. Contact your OMRON sales representative for more detailed information on other operating environments.
  4. At the operation limit positions.
  5. Only for plunger, sealed plunger, roller arm lever, and sealed roller arm lever.
  6. Only for crossroller plunger, sealed crossroller plunger, roller plunger, and sealed roller plunger.

## Connections

### ■ Contact Form

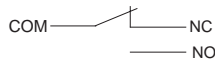

**Note:** With the XE-□, XV-□, and XV2-□, be sure to connect COM to the + terminal.

# Nomenclature

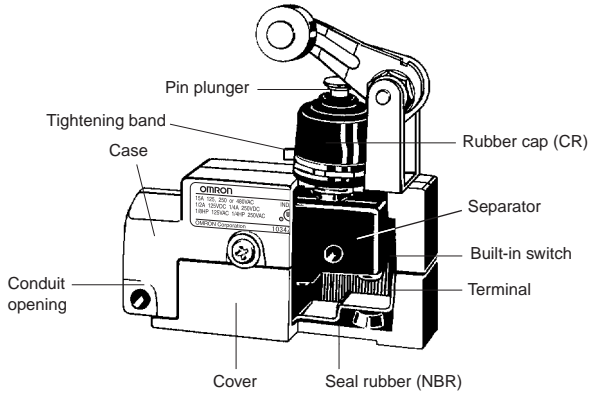

# Engineering Data

## Electrical Durability

ZE ( $\cos\phi = 1$ )

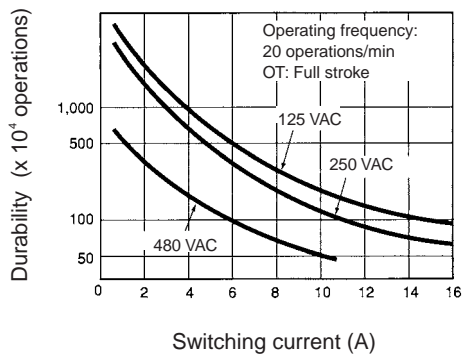

XE ( $L/R = 0$ )

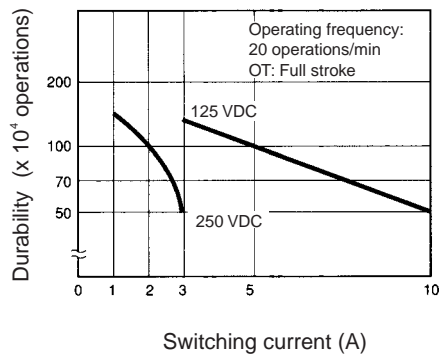

ZE ( $\cos\phi = 0.4$ )

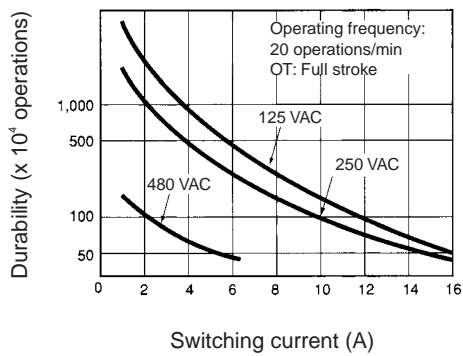

XE ( $L/R = 7$  ms)

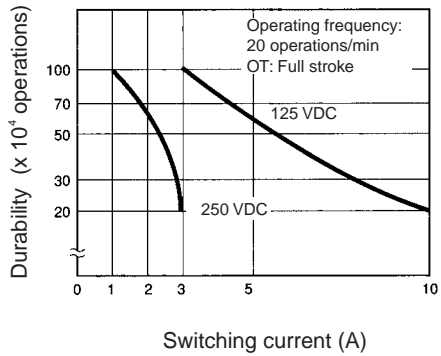

# Dimensions

**Note:** 1. All units are in millimeters unless otherwise indicated.

2. Unless otherwise specified, a tolerance of  $\pm 0.4$  mm applies to all dimensions.

3. In the drawings for the Base Mounting Type Switches (ZV), the mounting surfaces (flanges) are shown by lines of alternate long and two short dashes.

## Side Mounting

### Plunger ZE-Q-2, XE-Q-2

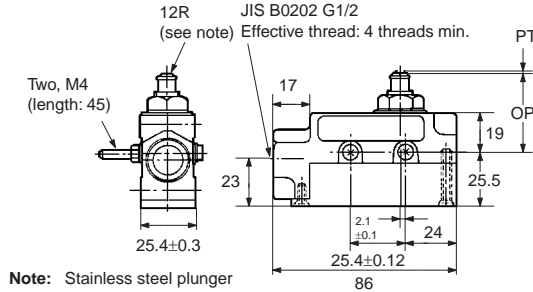
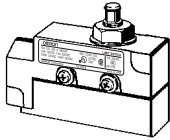

**Note:** Stainless steel plunger

Model	ZE-Q-2	XE-Q-2
OF	2.45 to 3.43 N	5.00 N max.
RF min.	1.12 N	1.12 N
PT max.	0.4 mm	0.9 mm
OT min.	5.5 mm	5.5 mm
MD max.	0.05 mm	0.47 mm
OP	38.2 $\pm$ 0.8 mm	

### Roller Plunger ZE-Q22-2, XE-Q22-2

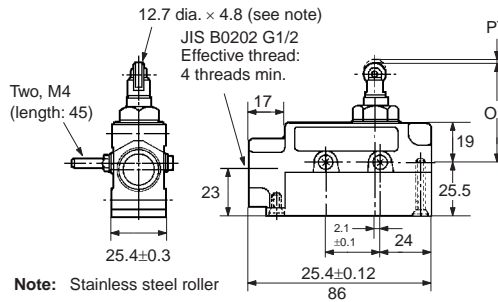
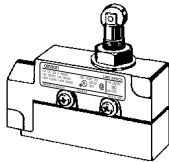

**Note:** Stainless steel roller

Model	ZE-Q22-2	XE-Q22-2
OF	2.45 to 3.43 N	5.00 N max.
RF min.	1.12 N	1.12 N
PT max.	0.5 mm	0.9 mm
OT min.	3.6 mm	3.6 mm
MD max.	0.05 mm	0.47 mm
OP	49.7 $\pm$ 1 mm	

### Crossroller Plunger ZE-Q21-2, XE-Q21-2

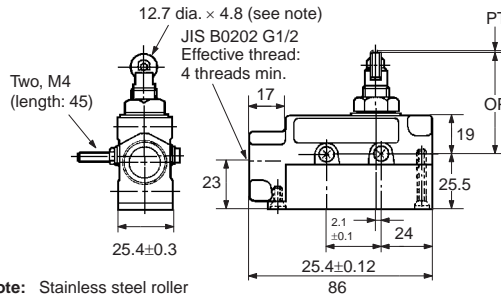
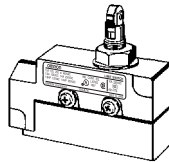

**Note:** Stainless steel roller

Model	ZE-Q21-2	XE-Q21-2
OF	2.45 to 3.43 N	5.00 N max.
RF min.	1.12 N	1.12 N
PT max.	0.5 mm	0.9 mm
OT min.	3.6 mm	3.6 mm
MD max.	0.05 mm	0.47 mm
OP	49.7 $\pm$ 1 mm	

**Roller Arm Lever**  
ZE-QA2-2, XE-QA2-2

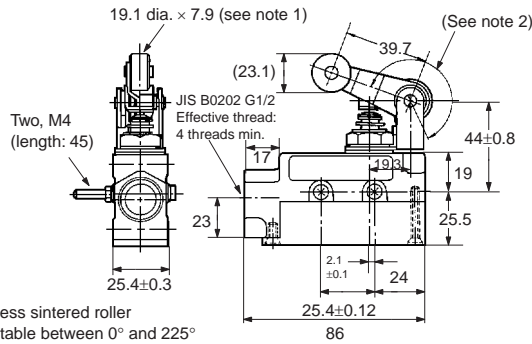
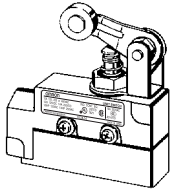

Note: 1. Stainless sintered roller  
2. Adjustable between 0° and 225°

Model	ZE-QA2-2	XE-QA2-2
OF	5.59 N max.	6.47N max.
RF min.	1.67 N	1.67 N
PT max.	4 mm	6 mm
OT min.	6 mm	5.5 mm
MD max.	0.4 mm	0.72 mm
OP	---	---

**One-way Action Roller Arm Lever**  
ZE-QA277-2, XE-QA277-2

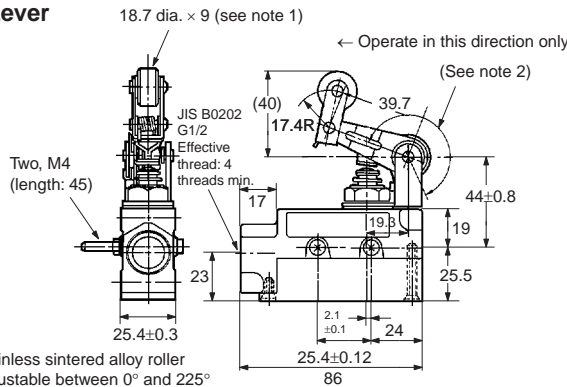
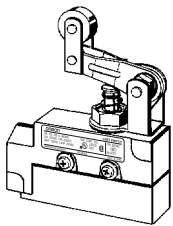

Note: 1. Stainless sintered alloy roller  
2. Adjustable between 0° and 225°

Model	ZE-QA277-2	XE-QA277-2
OF	5.59 N	6.47 N
RF min.	1.67 N	1.67 N
PT max.	4 mm	6 mm
OT min.	6 mm	5.5 mm
MD max.	0.4 mm	0.72 mm
OP	---	---

**Sealed Plunger**  
ZE-N-2, XE-N-2

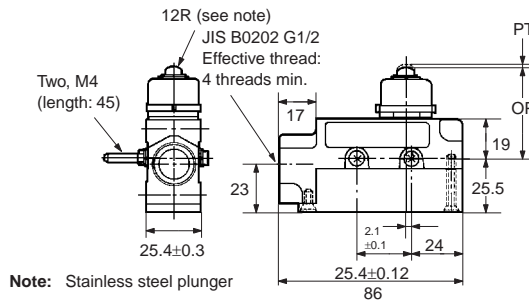
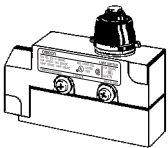

Note: Stainless steel plunger

Model	ZE-N-2	XE-N-2
OF	7.85 N	10.20 N
RF min.	2.35 N	2.35 N
PT max.	2 mm	3 mm
OT min.	5 mm	4 mm
MD max.	0.1 mm	0.47 mm
OP	45.8±0.8 mm	

**Sealed Roller Plunger**  
ZE-N22-2

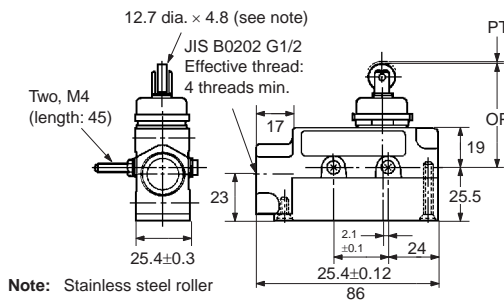
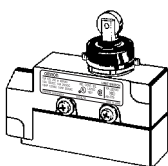

Note: Stainless steel roller

Model	ZE-N22-2
OF	4.90 N
RF min.	0.98 N
PT max.	1 mm
OT min.	3.5 mm
MD max.	0.12 mm
OP	49.7±0.8 mm

**Sealed Crossroller Plunger**  
ZE-N21-2

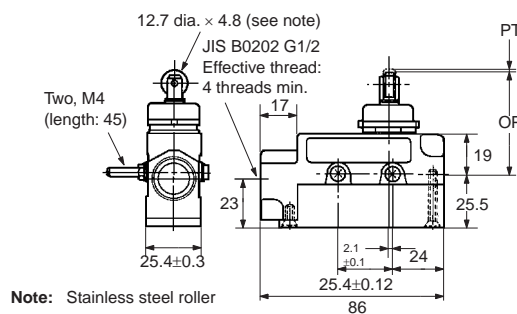
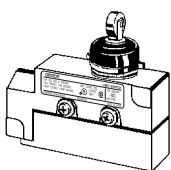

Note: Stainless steel roller

Model	ZE-N21-2
OF	4.90 N
RF min.	0.98 N
PT max.	1 mm
OT min.	3.5 mm
MD max.	0.12 mm
OP	49.7±0.8 mm

**Sealed Roller Arm Lever**  
ZE-NA2-2, XE-NA2-2

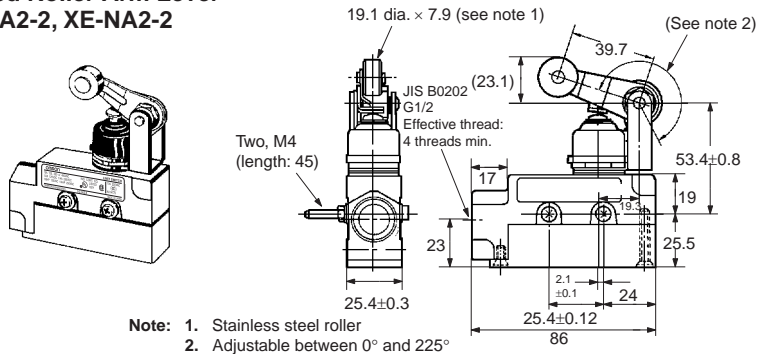

Model	ZE-NA2-2	XE-NA2-2
OF	6.28 N	7.26 N
RF min.	2.26 N	2.26 N
PT max.	5 mm	6 mm
OT min.	6 mm	5.5 mm
MD max.	0.4 mm	0.72 mm
OP	---	---

**One-way Action Sealed Roller Arm Lever**  
ZE-NA277-2, XE-NA277-2

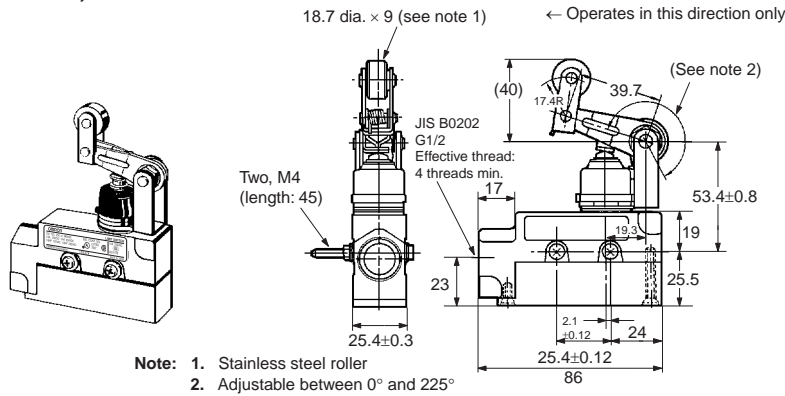

Model	ZE-NA277-2	XE-NA277-2
OF	6.28 N	7.26 N
RF min.	2.26 N	2.26 N
PT max.	5 mm	6 mm
OT min.	6 mm	5.5 mm
MD max.	0.4 mm	0.72 mm
OP	---	---

**Base Mounting/Diagonal Side Mounting**

**Plunger**  
ZV(2)-Q-2, XV(2)-Q-2

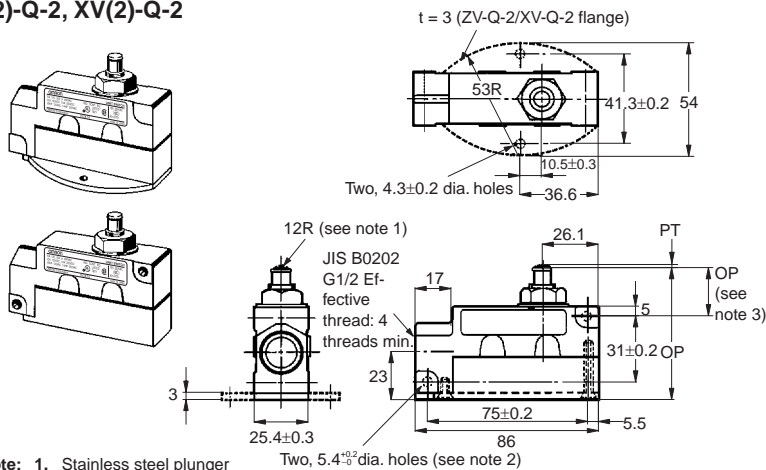

- Note:** 1. Stainless steel plunger  
 2. Only the ZV2-Q-2 and XV2-Q-2 incorporate mounting holes.  
 3. OP for ZV2-Q-2 and XV2-Q-2 is 24.2 ±0.8 mm.

Model	ZV(2)-Q-2	XV(2)-Q-2
OF	2.45 to 3.43 N	5.00 N max.
RF min.	1.12 N	1.12 N
PT max.	0.4 mm	0.9 mm
OT min.	5.5 mm	5.5 mm
MD max.	0.05 mm	0.47 mm
OP	63.7±0.8 mm (ZV-Q-2, XV-Q-2)	

**Roller Plunger**  
ZV(2)-Q22-2, XV(2)-Q22-2

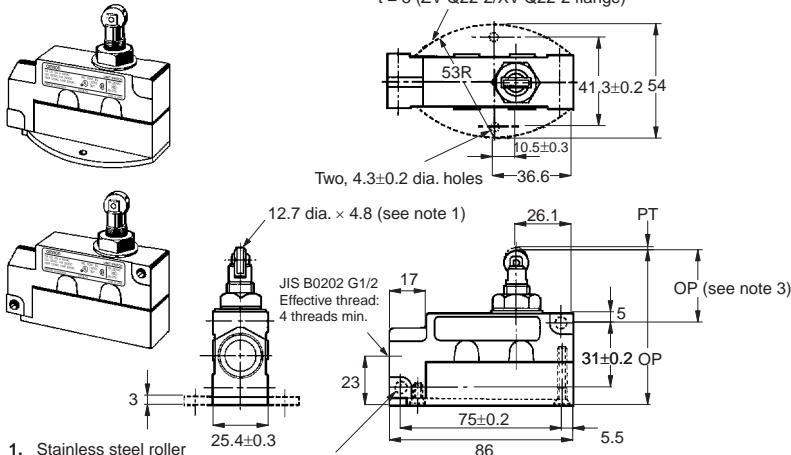

- Note:**
1. Stainless steel roller
  2. Only the ZV2-Q22-2 and XV2-Q22-2 incorporate mounting holes.
  3. OP for ZV2-Q22-2 and XV2-Q22-2 is 35.7 ± 1 mm.

Model	ZV(2)-Q22-2	XV(2)-Q22-2
OF	2.45 to 3.43 N	5.00 N max.
RF min.	1.12 N	1.12 N
PT max.	0.5 mm	0.9 mm
OT min.	3.6 mm	3.6 mm
MD max.	0.05 mm	0.47 mm
OP	75.2±0.8 mm (ZV-Q-22-2, XV-Q21-2)	

**Crossroller Plunger**  
ZV(2)-Q21-2, XV(2)-Q21-2

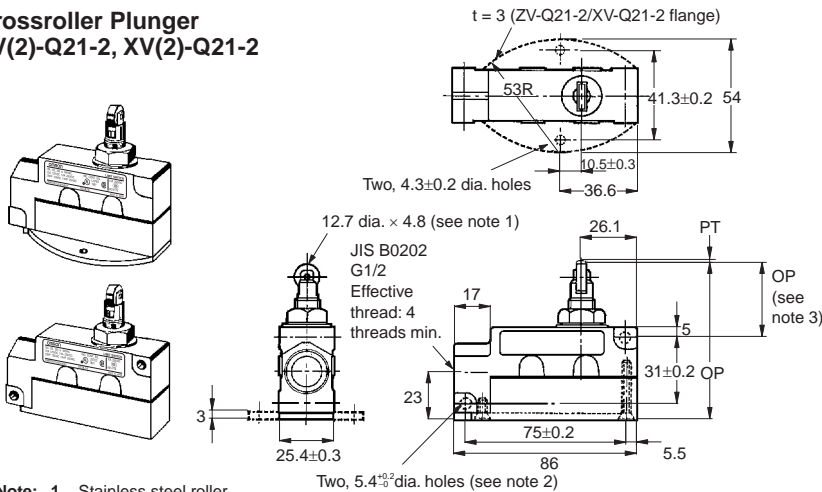

- Note:**
1. Stainless steel roller
  2. Only the ZV2-Q21-2 and XV2-Q21-2 incorporate mounting holes.
  3. OP for ZV2-Q21-2 and XV2-Q21-2 is 35.7 ± 0.8 mm.

Model	ZV(2)-Q21-2	XV(2)-Q21-2
OF	2.45 to 3.43 N	5.00 N max.
RF min.	1.12 N	1.12 N
PT max.	0.5 mm	0.9 mm
OT min.	3.6 mm	3.6 mm
MD max.	0.05 mm	0.47 mm
OP	75.2±0.8 mm (ZV-Q22-2, XV-Q21-2)	

**Roller Arm Lever**  
ZV(2)-QA2-2, XV(2)-QA2-2

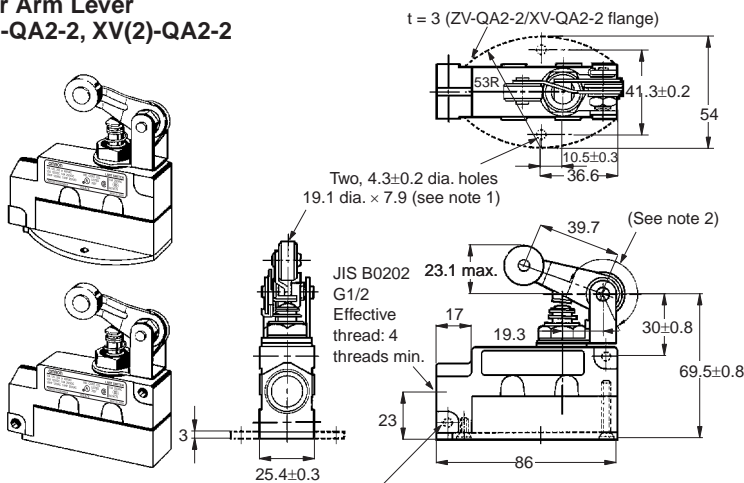

- Note:**
1. Stainless sintered alloy roller
  2. Adjustment between 0° to 225°.
  3. Only the ZV2-QA2-2 and XV2-QA2-2 incorporate mounting holes.

Model	ZV(2)-QA2-2	XV(2)-QA2-2
OF	5.59 N max.	6.47 N max.
RF min.	1.67 N	1.67 N
PT max.	4 mm	6 mm
OT min.	6 mm	5.5 mm
MD max.	0.4 mm	0.72 mm
OP	---	



**One-way Action Roller Arm Lever**  
ZV(2)-QA277-2, XV(2)-QA277-2

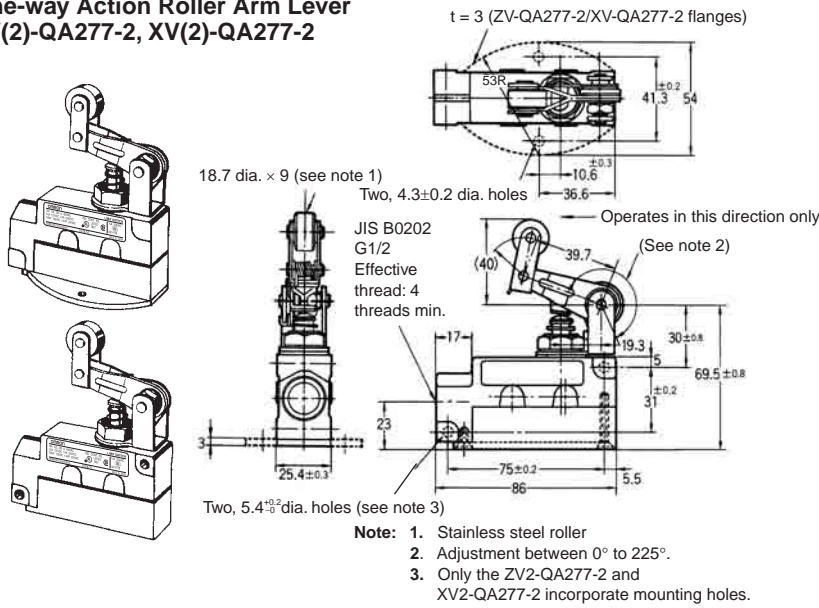

Model	ZV(2)-QA277-2	XV(2)-QA277-2
OF	5.59 N	6.47 N
RF min.	1.67 N	1.67 N
PT max.	4 mm	6 mm
OT min.	6 mm	5.5 mm
MD max.	0.4 mm	0.72 mm
OP	---	---

**Sealed Plunger**  
ZV(2)-N-2, XV(2)-N-2

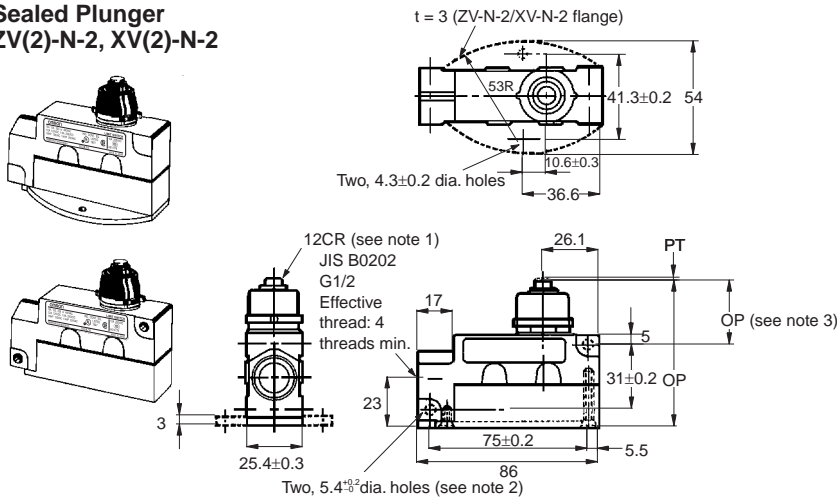

Model	ZV(2)-N-2	XV(2)-N-2
OF	7.85 N	10.20 N
RF min.	2.35 N	2.35 N
PT max.	2 mm	3 mm
OT min.	5 mm	4 mm
MD max.	0.1 mm	0.47 mm
OP	71.4±0.8 mm (ZV-N-2, XV-N-2)	

**Sealed Roller Plunger**  
ZV(2)-N22-2

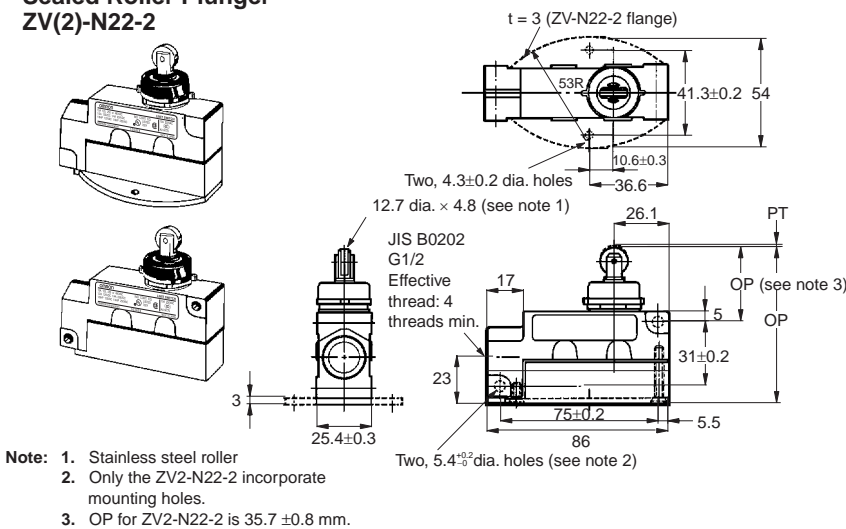

Model	ZV(2)-N22-2
OF	4.90 N
RF min.	0.98 N
PT max.	1 mm
OT min.	3.5 mm
MD max.	0.12 mm
OP	75.2±0.8 mm (ZV-N22-2, ZV-N21-2)

**Sealed Crossroller Plunger  
ZV(2)-N21-2**

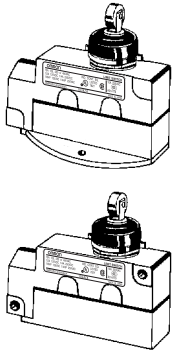

- Note:**
1. Stainless steel roller
  2. Only the ZV2-N21-2 incorporate mounting holes.
  3. OP for ZV2-N21-2 is 35.7 ±0.8 mm.

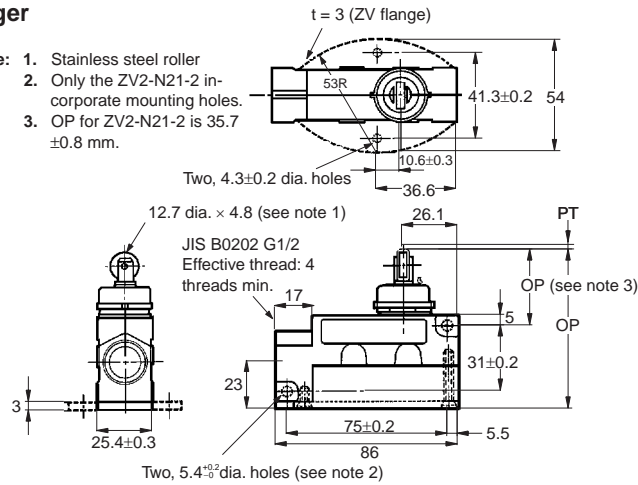

Model	ZV(2)-N21-2
OF	4.90 N
RF min.	0.98 N
PT max.	1 mm
OT min.	3.5 mm
MD max.	0.12 mm
OP	75.2±0.8 mm (ZV-N22-2, ZV-N21-2)

**Sealed Roller Arm Lever  
ZV(2)-NA2-2, XV(2)-NA2-2**

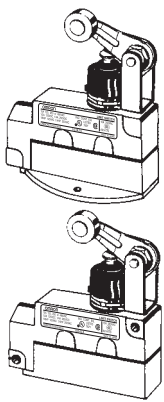

- Note:**
1. Stainless steel roller
  2. Adjustment between 0° to 225°.
  3. Only the ZV2-NA2-2 and XV2-NA2-2 incorporate mounting holes.

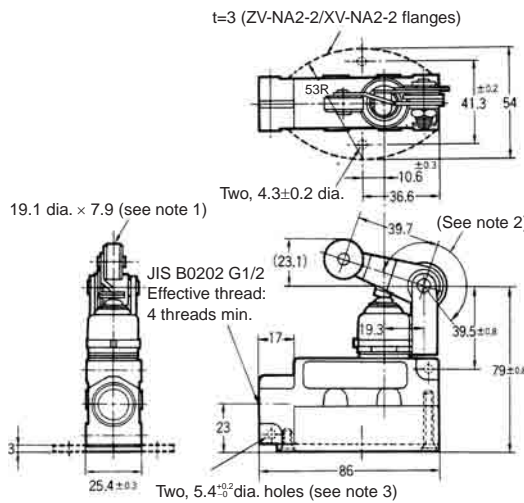

Model	ZV(2)-NA2-2	XV(2)-NA2-2
OF	6.28 N	7.26 N
RF min.	2.26 N	2.26 N
PT max.	5 mm	6 mm
OT min.	6 mm	5.5 mm
MD max.	0.4 mm	0.72 mm
FP max.	---	---
OP	---	---

**One-way Action Sealed Roller Arm Lever  
ZV(2)-NA277-2, XV(2)-NA277-2**

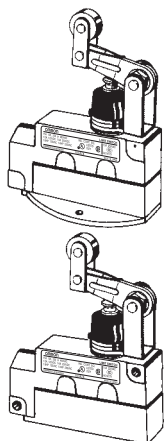

- Note:**
1. Stainless steel roller
  2. Adjustment between 0° to 225°.
  3. Only the ZV2-NA277-2 and XV2-NA277-2 incorporate mounting holes.

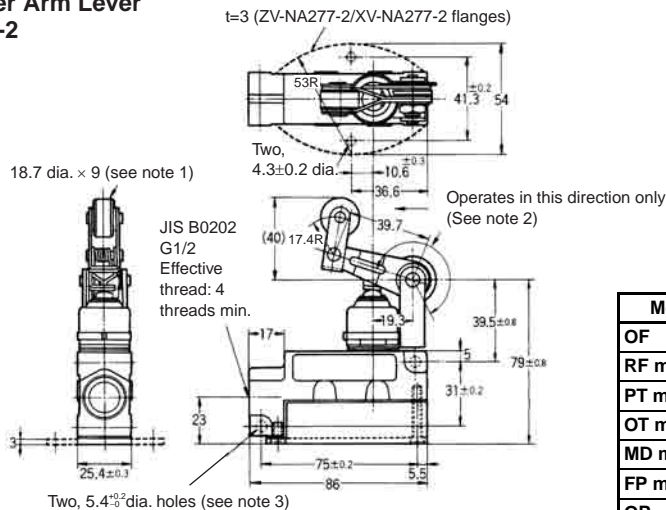

Model	ZV(2)-NA277-2	XV(2)-NA277-2
OF	6.28 N	7.26 N
RF min.	2.26 N	2.26 N
PT max.	5 mm	6 mm
OT min.	6 mm	5.5 mm
MD max.	0.4 mm	0.72 mm
FP max.	---	---
OP	---	---

# Precautions

Refer to the "Precautions for General-purpose Limit Switches (Including Multiple Limit Switches, Mechanical Touch Switches, High-precision Switches, Touch Switches, On-site Flexible Switches; Not Including Safety Switches)" on page 17.

## Correct Use

### Operating Environment

- Seal material may deteriorate if a Switch is used outdoor or where subject to special cutting oils, solvents, or chemicals. Always appraise performance under actual application conditions and set suitable maintenance and replacement periods.
- Be sure to protect part A with grease in order to maintain the mechanical durability and performance of the Limit Switch. The use of molybdenum disulfide grease is recommended.

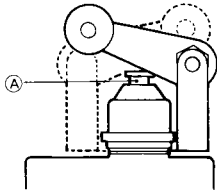

- Install Switches where they will not be directly subject to cutting chips, dust, or dirt. The Actuator and Switch must also be protected from the accumulation of cutting chips or sludge.

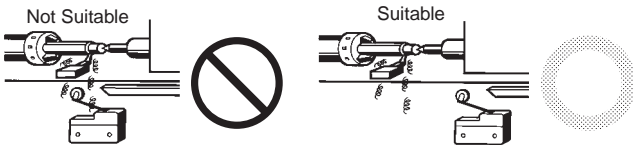

- Constantly subjecting a Switch to vibration or shock can result in wear, which can lead to contact interference with contacts, operation failure, reduced durability, and other problems. Excessive vibration or shock can lead to false contact operation or damage. Install Switches in locations not subject to shock and vibration and in orientations that will not produce resonance.
- The Switches have physical contacts. Using them in environments containing silicon gas will result in the formation of silicon oxide (SiO<sub>2</sub>) due to arc energy. If silicon oxide accumulates on the contacts, contact interference can occur. If silicon oil, silicon filling agents, silicon cables, or other silicon products are present near the Switch, suppress arcing with contact protective circuits (surge killers) or remove the source of silicon gas.

### Mounting

With the Roller Lever-type Enclosed Switches, the roller arm has been temporarily tightened prior to shipment, so that its position may be adjusted later. When mounting the Switch, be sure to re-tighten the roller arm so as to prevent it from becoming loose during operation.

To adequately maintain the seals at the mounting screw section on the side of the Enclosed Switch, insert each O-ring correctly and secure it with the lock nut.

To provide the Switch with improved sealing property, use of the SC Connector is recommended.

When routing wires into the conduit opening, be sure that cuttings and other foreign matter do not enter the Switch.

### Tightening Torque

A loose screw may result in a malfunction. Be sure to tighten each screw to the proper tightening torque as shown below.

No.	Type	Torque
1	Cover mounting screw	1.18 to 1.37 N·m
2	Switch mounting screw (see note 1)	1.18 to 1.37 N·m
3	Switch mounting screw (see note 2)	4.90 to 5.88 N·m
4	Switch terminal screw (M4 screws for head)	0.78 to 1.18 N·m
5	Roller arm mounting nut	4.90 to 5.88 N·m

**Note:** 1. This torque range applies to side mounting or bottom mounting. (M4 screws for head)

2. This torque range applies to side diagonal mounting. (M5 Allen-head bolt)

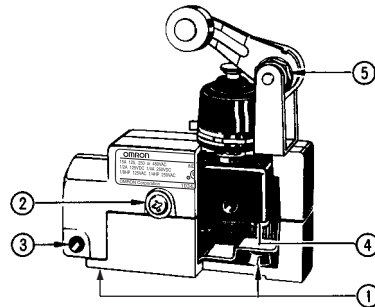

### Mounting

#### Mounting Holes

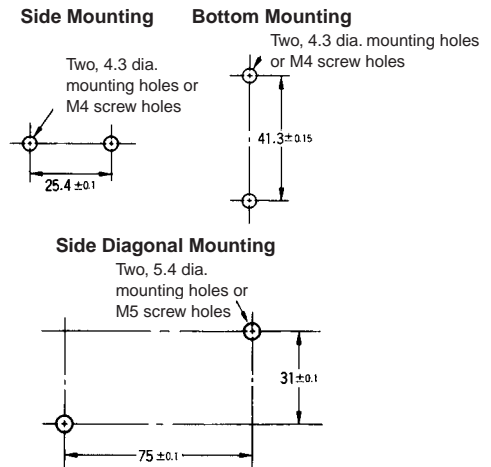

### Operation

- Operating method, shape of cam or dog, operating frequency, and the overtravel (OT) have significant effect on the service life and precision of the Limit Switch. Make sure that the shape of the cam is smooth enough.
- Check that OT has a sufficient margin. The actual OT should be rated OT x 0.7 to 1.

## Dedicated Wrench

The roller arm can be set freely within a range of 225° after loosening the nut.

The roller arm mounting bracket can be set in any direction after loosening the nut.

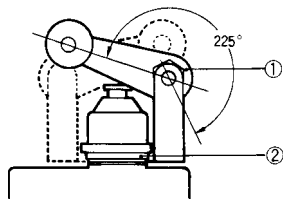

A dedicated wrench is provided separately.

Model: SUPANA FOR ZE

Make sure that the nut is free of foreign substances when the nut is loosened.

# Terms and Conditions of Sale

1. **Offer; Acceptance.** These terms and conditions (these "Terms") are deemed part of all quotes, agreements, purchase orders, acknowledgments, price lists, catalogs, manuals, brochures and other documents, whether electronic or in writing, relating to the sale of products or services (collectively, the "Products") by Omron Electronics LLC and its subsidiary companies ("Omron"). Omron objects to any terms or conditions proposed in Buyer's purchase order or other documents which are inconsistent with, or in addition to, these Terms.
2. **Prices; Payment Terms.** All prices stated are current, subject to change without notice by Omron. Omron reserves the right to increase or decrease prices on any unshipped portions of outstanding orders. Payments for Products are due net 30 days unless otherwise stated in the invoice.
3. **Discounts.** Cash discounts, if any, will apply only on the net amount of invoices sent to Buyer after deducting transportation charges, taxes and duties, and will be allowed only if (i) the invoice is paid according to Omron's payment terms and (ii) Buyer has no past due amounts.
4. **Interest.** Omron, at its option, may charge Buyer 1-1/2% interest per month or the maximum legal rate, whichever is less, on any balance not paid within the stated terms.
5. **Orders.** Omron will accept no order less than \$200 net billing.
6. **Governmental Approvals.** Buyer shall be responsible for, and shall bear all costs involved in, obtaining any government approvals required for the importation or sale of the Products.
7. **Taxes.** All taxes, duties and other governmental charges (other than general real property and income taxes), including any interest or penalties thereon, imposed directly or indirectly on Omron or required to be collected directly or indirectly by Omron for the manufacture, production, sale, delivery, importation, consumption or use of the Products sold hereunder (including customs duties and sales, excise, use, turnover and license taxes) shall be charged to and remitted by Buyer to Omron.
8. **Financial.** If the financial position of Buyer at any time becomes unsatisfactory to Omron, Omron reserves the right to stop shipments or require satisfactory security or payment in advance. If Buyer fails to make payment or otherwise comply with these Terms or any related agreement, Omron may (without liability and in addition to other remedies) cancel any unshipped portion of Products sold hereunder and stop any Products in transit until Buyer pays all amounts, including amounts payable hereunder, whether or not then due, which are owing to it by Buyer. Buyer shall in any event remain liable for all unpaid accounts.
9. **Cancellation; Etc.** Orders are not subject to rescheduling or cancellation unless Buyer indemnifies Omron against all related costs or expenses.
10. **Force Majeure.** Omron shall not be liable for any delay or failure in delivery resulting from causes beyond its control, including earthquakes, fires, floods, strikes or other labor disputes, shortage of labor or materials, accidents to machinery, acts of sabotage, riots, delay in or lack of transportation or the requirements of any government authority.
11. **Shipping; Delivery.** Unless otherwise expressly agreed in writing by Omron:
  - a. Shipments shall be by a carrier selected by Omron; Omron will not drop ship except in "break down" situations.
  - b. Such carrier shall act as the agent of Buyer and delivery to such carrier shall constitute delivery to Buyer;
  - c. All sales and shipments of Products shall be FOB shipping point (unless otherwise stated in writing by Omron), at which point title and risk of loss shall pass from Omron to Buyer; provided that Omron shall retain a security interest in the Products until the full purchase price is paid;
  - d. Delivery and shipping dates are estimates only; and
  - e. Omron will package Products as it deems proper for protection against normal handling and extra charges apply to special conditions.
12. **Claims.** Any claim by Buyer against Omron for shortage or damage to the Products occurring before delivery to the carrier must be presented in writing to Omron within 30 days of receipt of shipment and include the original transportation bill signed by the carrier noting that the carrier received the Products from Omron in the condition claimed.
13. **Warranties.** (a) **Exclusive Warranty.** Omron's exclusive warranty is that the Products will be free from defects in materials and workmanship for a period of twelve months from the date of sale by Omron (or such other period expressed in writing by Omron). Omron disclaims all other warranties, express or implied. (b) **Limitations.** OMRON MAKES NO WARRANTY OR REPRESENTATION, EXPRESS OR IMPLIED, ABOUT NON-INFRINGEMENT, MERCHANTABILITY OR FITNESS FOR A PARTICULAR PURPOSE OF THE PRODUCTS. BUYER ACKNOWLEDGES THAT IT ALONE HAS DETERMINED THAT THE PRODUCTS WILL SUITABLY MEET THE REQUIREMENTS OF THEIR INTENDED USE. Omron further disclaims all warranties and responsibility of any type for claims or expenses based on infringement by the Products or otherwise of any intellectual property right. (c) **Buyer Remedy.** Omron's sole obligation hereunder shall be, at Omron's election, to (i) replace (in the form originally shipped with Buyer responsible for labor charges for removal or replacement thereof) the non-complying Product, (ii) repair the non-complying Product, or (iii) repay or credit Buyer an amount equal to the purchase price of the non-complying Product; provided that in no event shall Omron be responsible for warranty, repair, indemnity or any other claims or expenses regarding the Products unless Omron's analysis confirms that the Products were properly handled, stored, installed and maintained and not subject to contamination, abuse, misuse or inappropriate modification. Return of any Products by Buyer must be approved in writing by Omron before shipment. Omron Companies shall not be liable for the suitability or unsuitability or the results from the use of Products in combination with any electrical or electronic components, circuits, system assemblies or any other materials or substances or environments. Any advice, recommendations or information given orally or in writing, are not to be construed as an amendment or addition to the above warranty. See <http://oeweb.omron.com> or contact your Omron representative for published information.
14. **Limitation on Liability; Etc.** OMRON COMPANIES SHALL NOT BE LIABLE FOR SPECIAL, INDIRECT, INCIDENTAL, OR CONSEQUENTIAL DAMAGES, LOSS OF PROFITS OR PRODUCTION OR COMMERCIAL LOSS IN ANY WAY CONNECTED WITH THE PRODUCTS, WHETHER SUCH CLAIM IS BASED IN CONTRACT, WARRANTY, NEGLIGENCE OR STRICT LIABILITY. Further, in no event shall liability of Omron Companies exceed the individual price of the Product on which liability is asserted.
15. **Indemnities.** Buyer shall indemnify and hold harmless Omron Companies and their employees from and against all liabilities, losses, claims, costs and expenses (including attorney's fees and expenses) related to any claim, investigation, litigation or proceeding (whether or not Omron is a party) which arises or is alleged to arise from Buyer's acts or omissions under these Terms or in any way with respect to the Products. Without limiting the foregoing, Buyer (at its own expense) shall indemnify and hold harmless Omron and defend or settle any action brought against such Companies to the extent based on a claim that any Product made to Buyer specifications infringed intellectual property rights of another party.
16. **Property; Confidentiality.** Any intellectual property in the Products is the exclusive property of Omron Companies and Buyer shall not attempt to duplicate it in any way without the written permission of Omron. Notwithstanding any charges to Buyer for engineering or tooling, all engineering and tooling shall remain the exclusive property of Omron. All information and materials supplied by Omron to Buyer relating to the Products are confidential and proprietary, and Buyer shall limit distribution thereof to its trusted employees and strictly prevent disclosure to any third party.
17. **Export Controls.** Buyer shall comply with all applicable laws, regulations and licenses regarding (i) export of products or information; (ii) sale of products to "forbidden" or other proscribed persons; and (iii) disclosure to non-citizens of regulated technology or information.
18. **Miscellaneous.** (a) **Waiver.** No failure or delay by Omron in exercising any right and no course of dealing between Buyer and Omron shall operate as a waiver of rights by Omron. (b) **Assignment.** Buyer may not assign its rights hereunder without Omron's written consent. (c) **Law.** These Terms are governed by the law of the jurisdiction of the home office of the Omron company from which Buyer is purchasing the Products (without regard to conflict of law principles). (d) **Amendment.** These Terms constitute the entire agreement between Buyer and Omron relating to the Products, and no provision may be changed or waived unless in writing signed by the parties. (e) **Severability.** If any provision hereof is rendered ineffective or invalid, such provision shall not invalidate any other provision. (f) **Setoff.** Buyer shall have no right to set off any amounts against the amount owing in respect of this invoice. (g) **Definitions.** As used herein, "including" means "including without limitation"; and "Omron Companies" (or similar words) mean Omron Corporation and any direct or indirect subsidiary or affiliate thereof.

## Certain Precautions on Specifications and Use

1. **Suitability of Use.** Omron Companies shall not be responsible for conformity with any standards, codes or regulations which apply to the combination of the Product in the Buyer's application or use of the Product. At Buyer's request, Omron will provide applicable third party certification documents identifying ratings and limitations of use which apply to the Product. This information by itself is not sufficient for a complete determination of the suitability of the Product in combination with the end product, machine, system, or other application or use. Buyer shall be solely responsible for determining appropriateness of the particular Product with respect to Buyer's application, product or system. Buyer shall take application responsibility in all cases but the following is a non-exhaustive list of applications for which particular attention must be given:
  - (i) Outdoor use, uses involving potential chemical contamination or electrical interference, or conditions or uses not described in this document.
  - (ii) Use in consumer products or any use in significant quantities.
  - (iii) Energy control systems, combustion systems, railroad systems, aviation systems, medical equipment, amusement machines, vehicles, safety equipment, and installations subject to separate industry or government regulations.
  - (iv) Systems, machines and equipment that could present a risk to life or property. Please know and observe all prohibitions of use applicable to this Product.

NEVER USE THE PRODUCT FOR AN APPLICATION INVOLVING SERIOUS RISK TO LIFE OR PROPERTY OR IN LARGE QUANTITIES WITHOUT ENSURING THAT THE SYSTEM AS A WHOLE HAS BEEN DESIGNED TO ADDRESS THE RISKS, AND THAT THE OMRON'S PRODUCT IS PROPERLY RATED AND INSTALLED FOR THE INTENDED USE WITHIN THE OVERALL EQUIPMENT OR SYSTEM.
2. **Programmable Products.** Omron Companies shall not be responsible for the user's programming of a programmable Product, or any consequence thereof.
3. **Performance Data.** Data presented in Omron Company websites, catalogs and other materials is provided as a guide for the user in determining suitability and does not constitute a warranty. It may represent the result of Omron's test conditions, and the user must correlate it to actual application requirements. Actual performance is subject to the Omron's Warranty and Limitations of Liability.
4. **Change in Specifications.** Product specifications and accessories may be changed at any time based on improvements and other reasons. It is our practice to change part numbers when published ratings or features are changed, or when significant construction changes are made. However, some specifications of the Product may be changed without any notice. When in doubt, special part numbers may be assigned to fix or establish key specifications for your application. Please consult with your Omron's representative at any time to confirm actual specifications of purchased Product.
5. **Errors and Omissions.** Information presented by Omron Companies has been checked and is believed to be accurate; however, no responsibility is assumed for clerical, typographical or proofreading errors or omissions.

Complete "Terms and Conditions of Sale" for product purchase and use are on Omron's website at [www.omron247.com](http://www.omron247.com) – under the "About Us" tab, in the Legal Matters section.

**ALL DIMENSIONS SHOWN ARE IN MILLIMETERS.**

To convert millimeters into inches, multiply by 0.03937. To convert grams into ounces, multiply by 0.03527.



**OMRON ELECTRONICS LLC**

1 Commerce Drive  
Schaumburg, IL 60173  
Tel: 847.843.7900

For U.S. technical support or other inquiries: 800.556.6766

**OMRON CANADA, INC.**

885 Milner Avenue  
Toronto, Ontario M1B 5V8  
Tel: 416.286.6465

**MEXICO SALES OFFICES**

**Mexico, D.F.** 555.660.3144  
**Ciudad Juárez** 656.623.7083  
**Monterrey, N.L.** 818.377.4281  
**Querétaro** 442.135.4510

**BRAZIL SALES OFFICE**

**Sao Paulo** 55.11.2101.6310

**ARGENTINA SALES OFFICE**

**Cono Sur** 54.114.787.1129

**CHILE SALES OFFICE**

**Santiago** 562.206.4592

**OTHER LATIN AMERICAN SALES**

**[mela@omron.com](mailto:mela@omron.com)**

**OMRON ON-LINE**

**Global -**

[www.omron.com](http://www.omron.com)

**USA -**

[www.omron247.com](http://www.omron247.com)

**Canada -**

[www.omron.ca](http://www.omron.ca)

**Brazil -**

[www.omron.com.br](http://www.omron.com.br)

**Latin America -**

[www.espanol.omron.com](http://www.espanol.omron.com)