

Modular Temperature Controller E5ZN

CSM_E5ZN_DS_E_3_1

New DIN Track Mounting Temperature Controller

- Two channels of temperature control available despite width of only 22.5 mm.
- The Temperature Controller itself can be replaced without changing terminal wiring.
- Use in combination with a compact Setting Display Unit to reduce communications programming requirements.
- Front-panel LED indicators for easy operation monitoring.
- Power supply and communications wiring not required between Units when mounted side-by-side.
- CompoWay/F communications protocol supported.
- UL, CSA, and CE Marking compliance.



Refer to *Safety Precautions* on page 11 to 12 and *Safety Precautions for All Temperature Controllers*.

Model Number Structure

■ Model Number Legend

E5ZN-□□□□□□-□
1 2 3 4 5 6 7

1. Control points

2: Two points

2. Control output

Q: Voltage (for driving SSR)

T: Transistor

C: Current

3. Auxiliary output

P: Two sourcing transistor outputs

N: Two sinking transistor outputs

4. Option

H: Heater burnout alarm

F: Transfer output (See note 1.)

5. Communications

03: RS-485

6. Input type

TC: Thermocouple

P: Platinum resistance thermometer

7. CompoWay/F serial communications

FLK: CompoWay/F serial communications

Note: 1. Transfer output can be specified only when the control output is a current output.

2. The above model number legend is intended as a functional description of models. Not all possible combinations of functions are available. Confirm model availability in *Ordering Information* on page 2 when ordering.

Example: Voltage output, two sinking transistor outputs, heater burnout alarm, thermocouple: E5ZN-2TNH03TC-FLK

Note: Be sure to read the precautions for correct use and other precautions in the following user's manual before using the Digital Controller.

E5ZN Modular Temperature Controller User's Manual (Cat. No. H113)

Ordering Information

List of Models

Name	Power supply	No. of control points	Control output	Auxiliary output	Functions	Communications functions	Input type (See note 5.)	Model	
Temperature Controller (See note 1.)	24 VDC	2	Voltage output (for SSRs)	Transistor output: 2 pts (sinking)	Heater burnout alarm (See note 3.)	RS-485	Thermocouple	E5ZN-2QNH03TC-FLK	
				Transistor output: 2 pts (sourcing)			Platinum resistance thermometer	E5ZN-2QNH03P-FLK	
				Transistor output			Transistor output: 2 pts (sinking)	Thermocouple	E5ZN-2QPH03TC-FLK
							Transistor output: 2 pts (sourcing)	Platinum resistance thermometer	E5ZN-2QPH03P-FLK
			Analog output (current output) (See note 2.)	Transistor output: 2 pts (sinking)	Thermocouple		E5ZN-2TNH03TC-FLK		
				Transistor output: 2 pts (sourcing)	Platinum resistance thermometer		E5ZN-2TNH03P-FLK		
			Transfer output (linear voltage output) (See note 2.)	Transfer output (linear voltage output) (See note 2.)	Thermocouple		E5ZN-2TPH03TC-FLK		
					Platinum resistance thermometer		E5ZN-2TPH03P-FLK		
				Transfer output (linear voltage output) (See note 2.)	Thermocouple		E5ZN-2CNF03TC-FLK		
					Platinum resistance thermometer		E5ZN-2CNF03P-FLK		
Transfer output (linear voltage output) (See note 2.)	Transfer output (linear voltage output) (See note 2.)	Thermocouple	E5ZN-2CPF03TC-FLK						
		Platinum resistance thermometer	E5ZN-2CPF03P-FLK						

- Note:**
- Terminal Units are required for wiring. Purchase separately.
 - When connecting the load of the controlled system, heat control output or cool control output can be allocated to the control output or auxiliary output. When connecting a recording device or Digital Panel Meter, transfer output can be allocated to control output or auxiliary output 3 or 4 of analog output models.
 - When using the heater burnout alarm, purchase a Current Transformer (E54-CT1 or E54-CT3) separately.
 - When using heating and cooling control functionality, the auxiliary output will be either heating control output or cooling control output.
 - Analog input and infrared temperature sensors (ES1B) can also be used with thermocouple models.

Terminal Unit

Name	No. of terminals	Functions	Model
Terminal Unit (Includes bus system without backplane.)	24	Equipped with communications terminals for power supply, communications, and setting devices.	E5ZN-SCT24S-500
	18 (See note 1.)	Not equipped with communications terminals for power supply, communications, and setting devices.	E5ZN-SCT18S-500

- Note:**
- When using 2 or more E5ZNs mounted side-by-side, use the E5ZN-SCT18S-500 for the second and subsequent Units. When using E5ZNs separately, be sure to use the E5ZN-SCT24S-500.
 - Two End Plates are provided with a E5ZN-SCT24S-500 Terminal Unit. Up to 16 Terminal Units can be used to expand the system to a maximum of 32 channels. When mounting to a DIN Track, be sure to mount End Plates on both sides.

Accessories (Order Separately)

Terminal Cover

Model	E53-COV12	E53-COV13
Type	For SCT24S-500 models	For SCT18S-500 models

Current Transformer (CT)

Model	E54-CT1	E54-CT3
Diameter	5.8 dia.	12.0 dia.

Sockets (for Setting Display Unit - Order Separately)

Model	P2CF-11	P2CF-11-E	P3GA-11	Y92A-48G
Type	Front-connecting socket	Front-connecting socket (with finger protection)	Back-connecting socket	Terminal cover for finger protection

Note: Refer to the following manual for precautionary information and other information necessary to use the E5ZN: E5ZN Temperature Controller Operation Manual (Cat. No. H113).

Setting Display Unit

Name	Power supply	Model
Setting Display Unit (See note.)	24 VDC	E5ZN-SDL

Note: Purchase sockets for wiring (shown on page 2) separately.

Specifications

Ratings

Power supply voltage	24 VDC		
Allowable voltage range	85% to 110% of the rated power supply voltage		
Power consumption	Approx. 3 W		
Sensor input	Thermocouple: K, J, T, E, L, U, N, R, S, B Infrared temperature sensor (ES1B series): 10 to 70°C, 60 to 120°C, 115 to 165°C, 140 to 260°C Voltage input: 0 to 50 mV		
	Platinum resistance thermometer: Pt100, JPt100		
Control output	Voltage output (for driving SSR)	Output voltage: 12 VDC ±15% (PNP); Maximum load current: 21 mA; Equipped with short-circuit protection circuit	
	Transistor output	Maximum operational voltage: 30 VDC; Maximum load current: 100 mA; Residual voltage: 1.5 V max.; Leakage current: 0.4 mA max.	
	Current output	Current output range: 4 to 20/0 to 20 mA DC; Load: 350 Ω max. (See note 2.)	
Auxiliary output	Transistor output	Sourcing	Maximum operating voltage: 30 VDC; Maximum load current: 50 mA; Residual voltage: 1.5 V max.; Leakage current: 0.4 mA max.
		Sinking	
	Linear voltage output	Voltage output range: 1 to 5/0 to 5 VDC; Load: 10 kΩ min.	
Event input	Contact output	ON: 1 kΩ max., OFF: 100 kΩ min. Discharge current: Approx. 7 mA	
	Non-contact output	ON: Residual voltage: 1.5 V max., OFF: Leakage current: 0.1 mA max. Discharge current: Approx. 7 mA	
Number of input and control points	Input points: 2, Control points: 2		
Setting method	Via communications or using the Setting Display Unit (E5ZN-SDL)		
Control method	2-PID or ON/OFF control		
Other functions	Heater burnout detection function, transfer output function Multi-SP and RUN/STOP switching using event input		
Ambient operating temperature	-10 to 55°C (with no icing or condensation) For 3 years of assured use: -10 to 50°C		
Ambient operating humidity	25% to 85%		
Storage temperature	-25 to 65°C (with no icing or condensation)		

- Note:** 1. Do not use an inverter output for the power supply. (Refer to *Safety Precautions for All Temperature Controllers.*)
2. OMRON G32A-EA Cycle Controller Unit (load impedance 352 Ω) can be used.

Input Range

Platinum Resistance Thermometer Models and Thermocouple Models

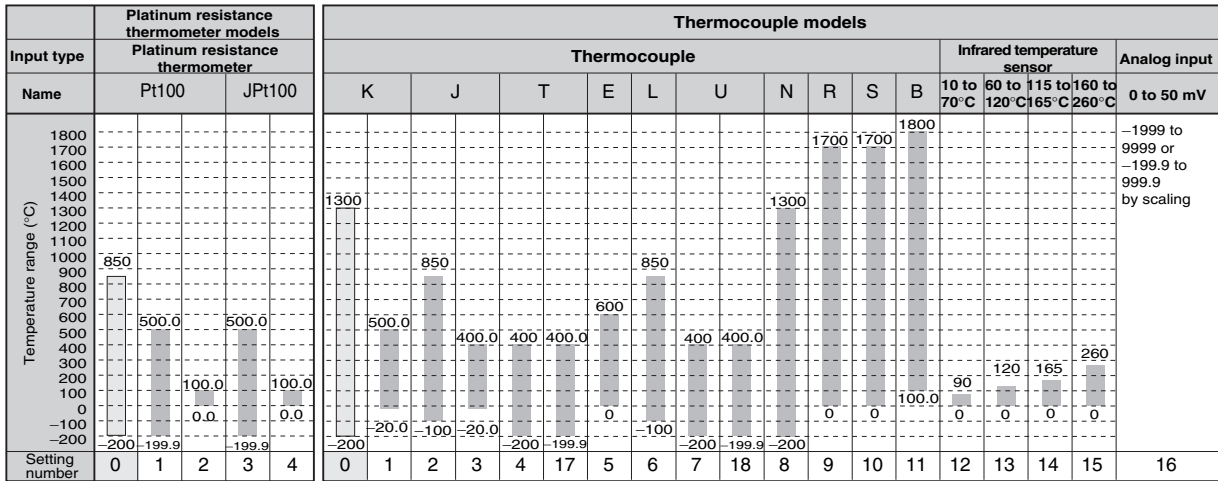

- The applicable standards for the input types are as follows:
- K, J, T, E, N, R, S, B: JIS C1602-1995, IEC584-1
 - L: Fe-CuNi, DIN 43710-1985
 - U: Cu-CuNi, DIN 43710-1985
 - JPt100: JIS C 1604-1989, JIS C 1606-1989
 - Pt100: JIS C 1604-1997 IEC 751
- Shaded parts indicate the settings at the time of purchase.

■ Characteristics

Indication accuracy	Thermocouple: (Indicated value $\pm 0.5\%$ or $\pm 1^\circ\text{C}$, whichever is greater) ± 1 digit max. (See note 1.) Platinum resistance thermometer: (Indicated value $\pm 0.5\%$ or $\pm 1^\circ\text{C}$, whichever is greater) ± 1 digit max. (See note 1.) Analog input: $\pm 0.5\%$ or ± 1 digit max. CT input: $\pm 5\%$ FS ± 1 digit max.
Influence of temperature	Thermocouple input (R, S, B): ($\pm 1\%$ of PV or $\pm 10^\circ\text{C}$, whichever is greater) ± 1 digit max. Other thermocouple input: ($\pm 1\%$ of PV or $\pm 4^\circ\text{C}$, whichever is greater) ± 1 digit max. *K thermocouple at -100°C max.: $\pm 10^\circ\text{C}$ max.
Influence of voltage	Platinum resistance thermometer: ($\pm 1\%$ of PV or $\pm 2^\circ\text{C}$, whichever is greater) ± 1 digit max. Analog input: ($\pm 1\%$ FS) ± 1 digit max.
Transfer output	Accuracy: $\pm 0.5\%$ FS (See note 2.)
Hysteresis	0.1 to 999.9 EU (in units of 0.1 EU) (See note 3.)
Proportional band (P)	0.1 to 999.9 EU (in units of 0.1 EU) (See note 3.)
Integral time (I)	0 to 3,999 s (in units of 1 s)
Derivative time (D)	0 to 3,999 s (in units of 1 s)
Control period	1 to 99 s (in units of 1 s)
Manual reset value	0.0 to 100.0% (in units of 0.1%)
Alarm setting range	-1,999 to 9,999 (Position of decimal point depends on input type.)
Sampling period	500 ms
Insulation resistance	20 M Ω min. (at 500 VDC)
Dielectric strength	600 VAC for 1 minute at 50 or 60 Hz (between unlike terminals of charged parts)
Vibration resistance	10 to 55 Hz, 10 m/s ² for 2 h each in X, Y, and Z directions
Shock resistance	150 m/s ² max., 3 times each in $\pm X$, $\pm Y$, and $\pm Z$ directions
Weight	Temperature Controller: Approx. 90 g Terminal Unit (18): Approx. 80 g Terminal Unit (24): Approx. 100 g
Degree of protection	Temperature Controller: IP00 Terminal Unit: IP00
Memory protection	EEPROM (non-volatile memory) (Number of write operations: 100,000)
Approved standards (See note 4.)	UL File No.: E200593 CSA File No.: 203889-1140084 CE EMS: ESD EN61326, EN61000-4-2 (4 kV/contact, 8 kV/air) REM field EN61326, EN61000-4-3 (10 V/m) Fast transient EN61326, EN61000-4-4 (2 kV/DC power, 1 kV/I/O) Surge immunity EN61326, EN61000-4-5 (line to ground: 2 kV/DC power 1 kV/I/O line to line: 1 kV/DC power) Conducted RF EN61326, EN61000-4-6 (10 V) EMI: Radiated EN61326 Class A

- Note: 1.** The indication accuracy for T and N thermocouples at -100°C , and for U and L thermocouples is $\pm 2^\circ\text{C} \pm 1$ digit max. There is no specification for the indication accuracy for the B thermocouple used at 400°C max. The indication accuracy for R and S thermocouples at 200°C max. is $\pm 3^\circ\text{C} \pm 1$ digit max.
- 2.** The transfer output accuracy for 0 to 4 mA when 0 to 20 mA DC is selected is $\pm 0.5\%$ FS +0.7 mA. The transfer output accuracy for 0 to 1 V when 0 to 5 VDC is selected is $\pm 0.5\%$ FS +0.175 V.
- 3.** "EU" stands for "Engineering Unit."
- 4.** In order to satisfy the EN61326 Class A standard for conducted emissions, install a noise filter (Densei-Lambda MXB-1206-33 or equivalent) in a DC power line as close to the E5ZN as possible.

■ Communications (Host Communications)

Transmission line connection method	RS-485 multipoint
Communications method	RS-485 (2-wire, half-duplex)
Synchronization method	Start-stop synchronization
Baud rate	4,800, 9,600, 19,200, or 38,400 bps
Transmission code	ASCII
Data bit length (See note.)	7 or 8 bits
Stop bit length (See note.)	1 or 2 bits
Error detection	Vertical parity (none, even, odd)
	BCC (block check character)
Flow control	None
Interface	RS-485
Retry function	None
Number of Units that can be connected in parallel	16 Units max. (32 channels)

Note: The baud rate, data bit length, stop bit length, and vertical parity can all be set independently as host communications settings.

□ : Default setting values

■ Setting Display Unit (Order Separately)

Power supply voltage	24 VDC
Allowable voltage range	85% to 110% of the rated power supply voltage
Power consumption	Approx. 1 W
Display method	7-segment digital display and single-color display
Ambient operating temperature	-10 to 55°C (with no icing or condensation) For 3 years of assured use: -10 to 50°C
Ambient operating humidity	25% to 85%
Storage temperature	-25 to 65°C (with no icing or condensation)
Communications method	RS-485 (half-duplex)
Communications format	Special protocol
Insulation resistance	20 MΩ min. (at 500 VDC)
Dielectric strength	1,500 VAC for 1 minute at 50 or 60 Hz (between unlike terminals of charged parts)
Vibration resistance	10 to 55 Hz, 20 m/s ² for 2 h each in X, Y, and Z directions
Shock resistance	300 m/s ² max., 3 times each in ±X, ±Y, and ±Z directions
Enclosure ratings	Front panel: IP50 Rear case: IP20 Terminal case: IP00
Memory protection	EEPROM (non-volatile memory) (Number of writes: 100,000)
Weight	Approx. 100 g Mounting bracket: Approx. 10 g

■ Current Transformer (CT) (Order Separately)

Dielectric strength	1,000 VAC (1 minute)
Vibration resistance	50 Hz, 98 m/s ²
Weight	E54-CT1: Approx. 11.5 g E54-CT3: Approx. 50 g
Accessories (E54-CT3 only)	Armature (2) Plug (2)

■ Heater Burnout Alarm

Maximum heater current	Single-phase, 50 A AC (See note 1.)
Input current readout accuracy	±5% FS ±1 digit max.
Heater burnout alarm setting range	0.0 to 50.0 A (in units of 0.1 A) (See note 2.)
Minimum detection ON time	190 ms (See note 3.)

- Note:**
1. Use the K8AC-H Digital Heater Burnout Alarm Detector for burnout detection of 3-phase heaters.
 2. If the heater burnout alarm setting is set to 0.0 A, the alarm is always OFF, and if it is set to 50.0 A the alarm is always ON.
 3. If the ON time for control output is less than 190 ms, heater burnout detection and heater current measurement will not be performed.

Installation

■ Connection Diagrams

- Voltage output (control output) is not electrically isolated from internal circuitry. Therefore, when using grounded thermocouples, do not ground control output terminals. (Doing so may result in temperature measurement errors due to unwanted current paths.)
- There is basic insulation between the power supply inputs and outputs for this product. If reinforced insulation is required, connect the input and output terminals to equipment without any exposed charge-carrying parts, or to equipment with basic insulation sufficient for the maximum operating voltage of the power supply and the inputs and outputs.
- To comply with the standards for noise terminal voltage for class A in EN 61326, install a noise filter (Densei Lamda MXB-1206-33 or the equivalent) to the DC power line as close as possible to the Temperature Controller.

Using with the E5ZN-SCT24S-500

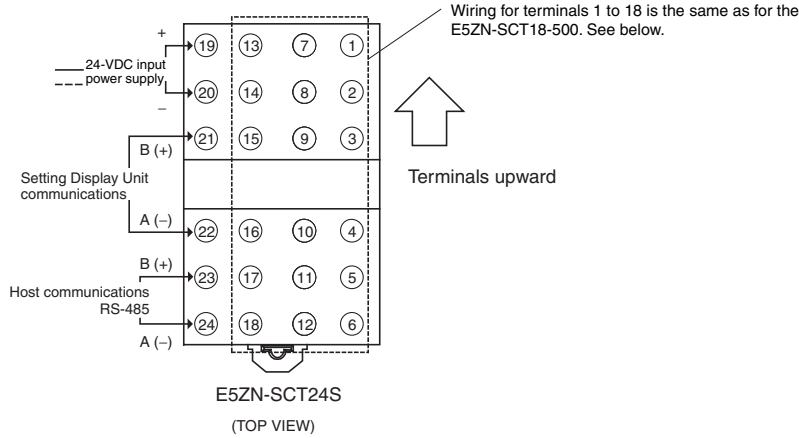

Using with the E5ZN-SCT18S-500

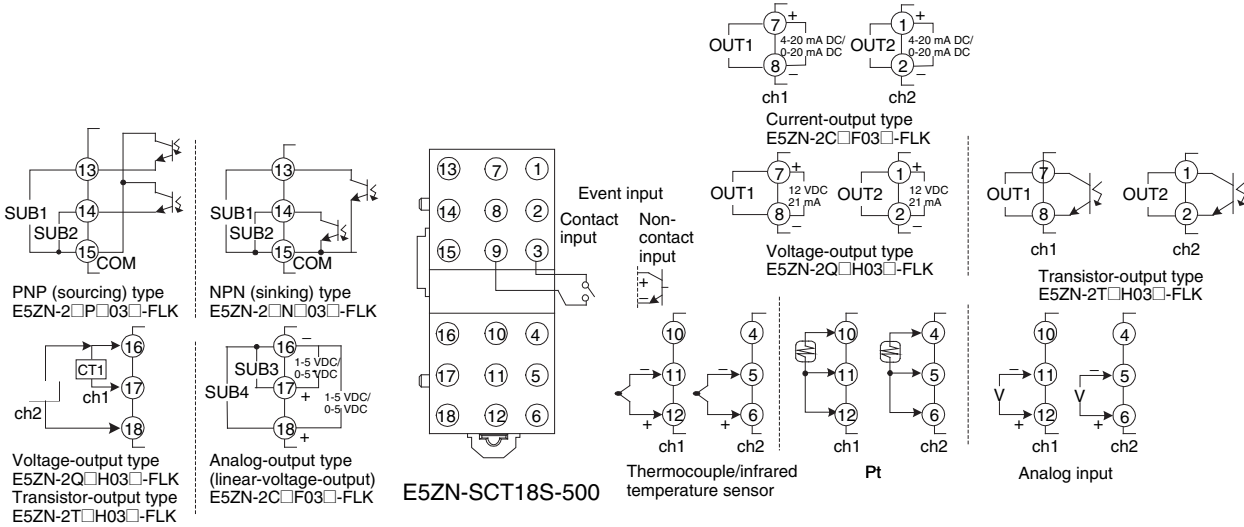

E5ZN-SDL

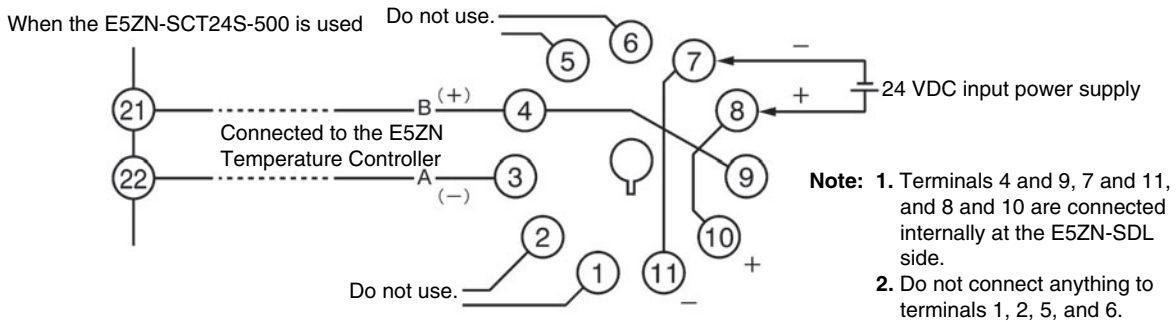

Note: Purchase either a P2CF-11 or a P3GA-11 Socket separately. (Refer to pages 10 to 11.)

Nomenclature

E5ZN-2

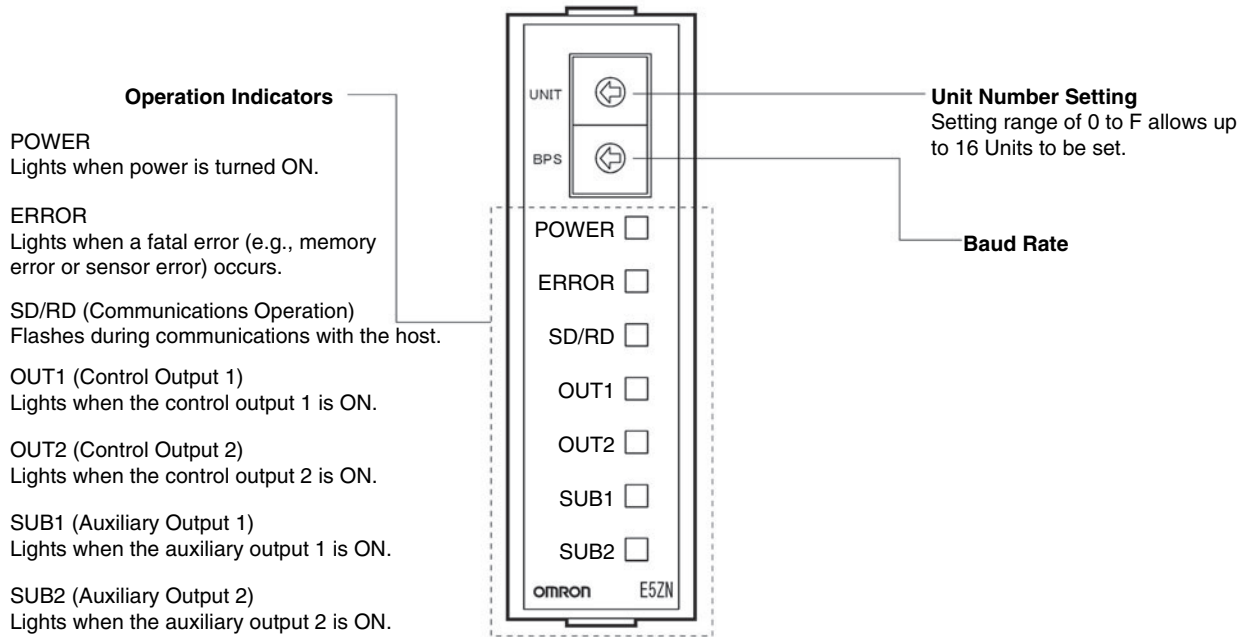

E5ZN-SDL

The following diagram shows the names and functions of the E5ZN-SDL parts for when it is connected to the E5ZN-2□□□□□□□□.

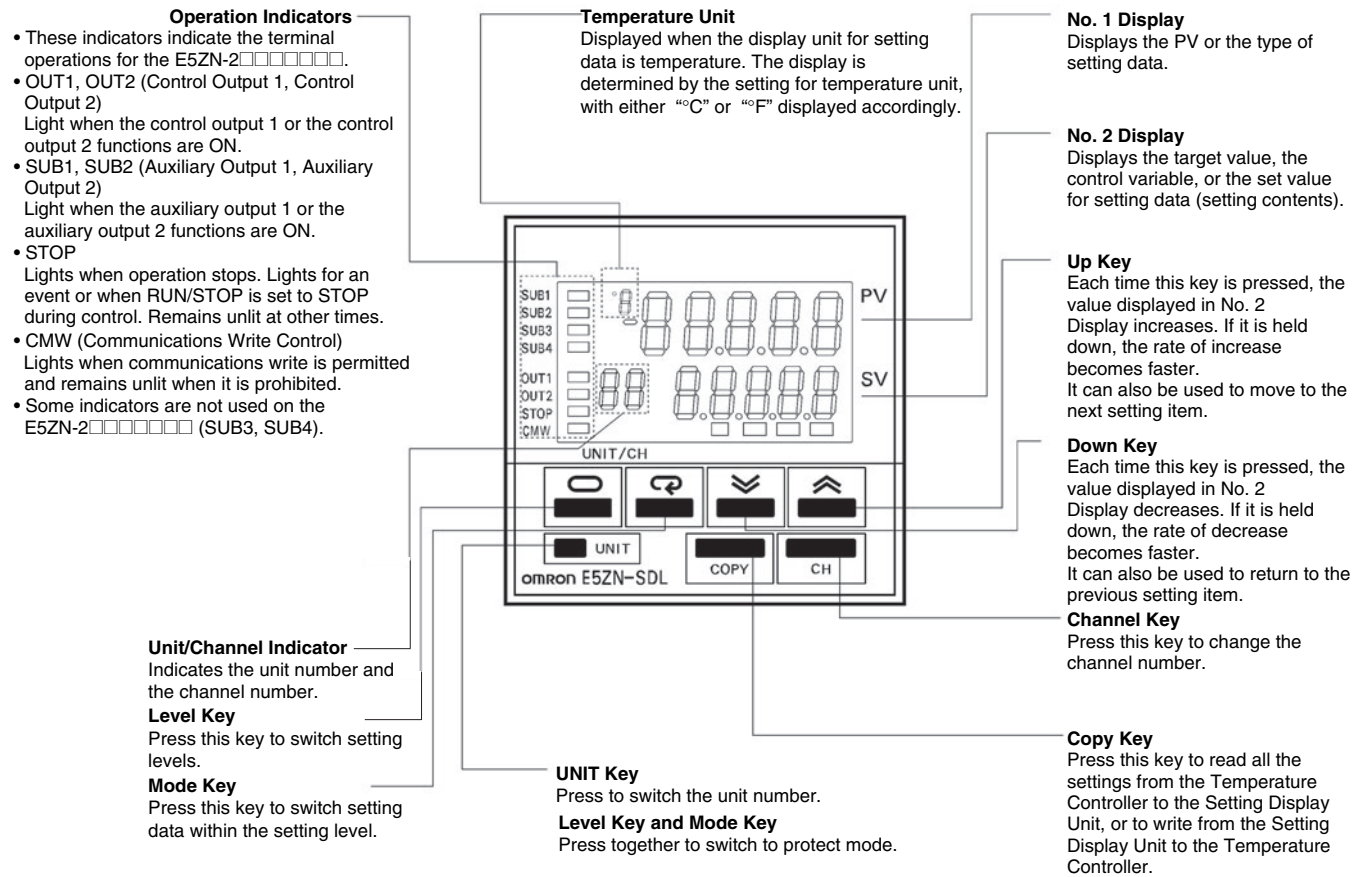

Dimensions

Note: All units are in millimeters unless otherwise indicated.

E5ZN-2□□□03□-FLK Connected to E5ZN-SCT24S-500

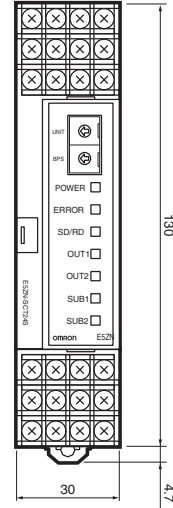
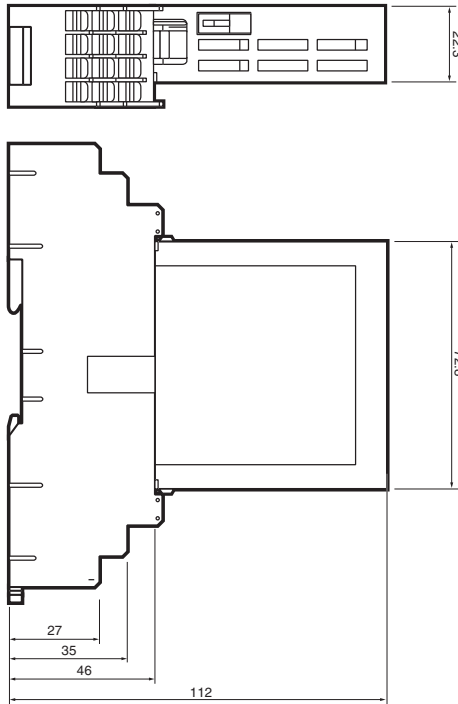
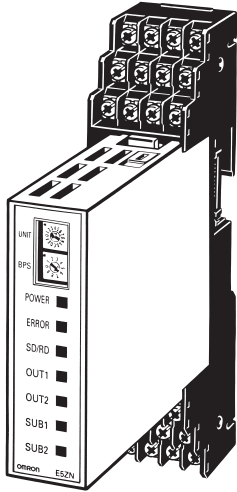

When only using one Unit, purchase the E5ZN-2□□□03□-FLK and the E5ZN-SCT24S-500 together. Also, when using horizontal side-by-side mounting, purchase the first Unit together with the E5ZN-SCT24S-500.

E5ZN-2□□□03□-FLK Connected to E5ZN-SCT18S-500

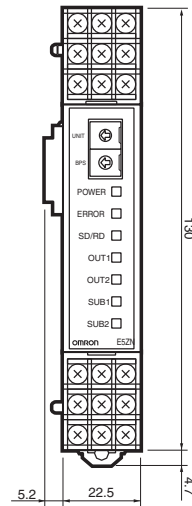
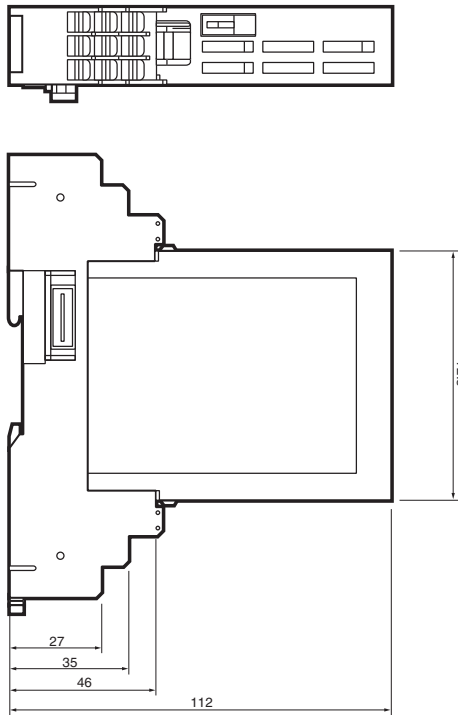
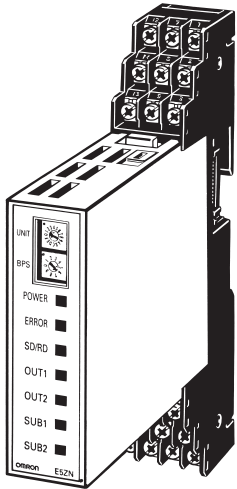

When mounting Units side-by-side, purchase the E5ZN-2□□□03□-FLK together with the E5ZN-SCT18S-500 for the second and subsequent Units.

■ End Plate

PFP-M

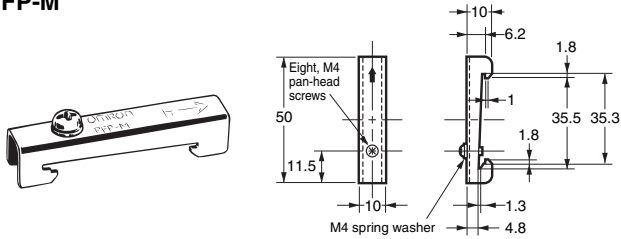

Note: End Plates are provided with the E5ZN-SCT24-500. Be sure to mount End Plates at both ends of Unit blocks.

■ Current Transformer (Order Separately)

E54-CT1

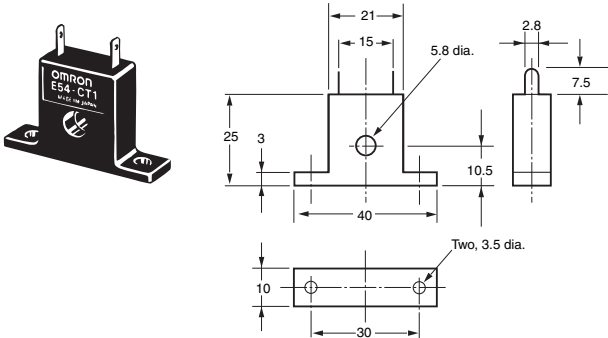

E54-CT3

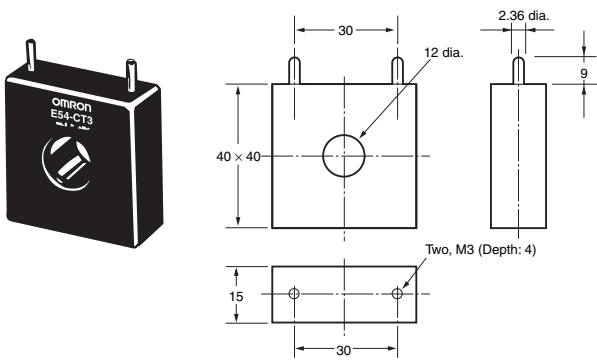

E54-CT3 Accessories Connection Example

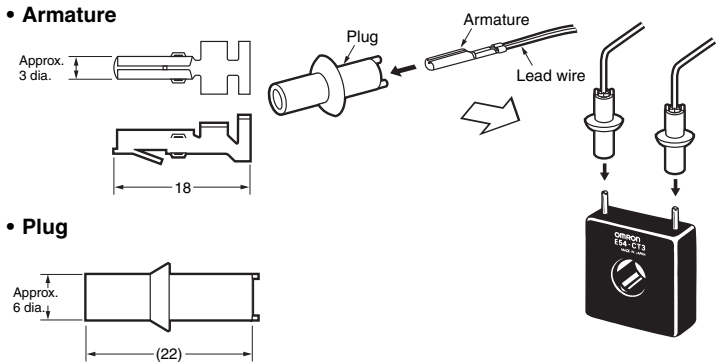

■ Terminal Cover (Order Separately)

E53-COV12

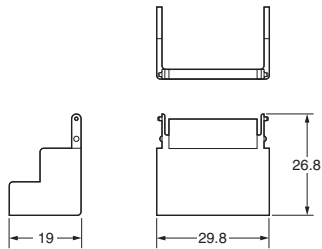

E53-COV13

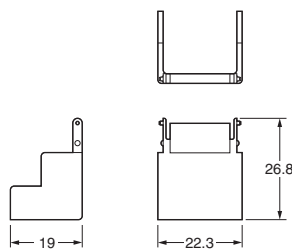

■ Rail Mounting Equipment (Order Separately)

Spacer

PFP-S

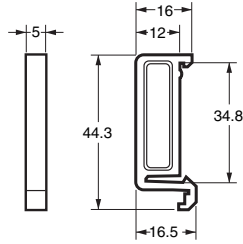
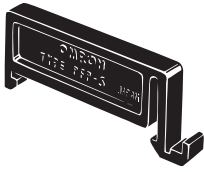

Mounting Track

PFP-100N

PFP-50N

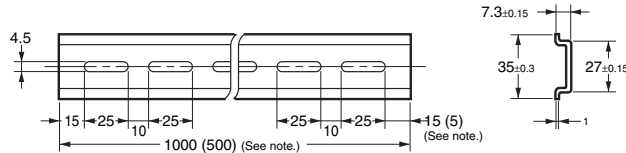
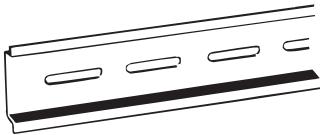

Note: The figures in parentheses are dimensions for the PFP-50N.

■ Setting Display Unit

E5ZN-SDL

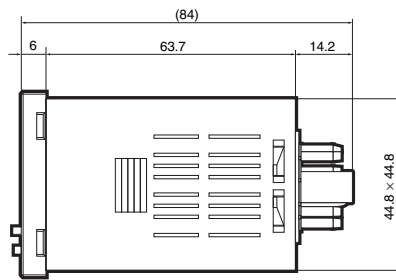
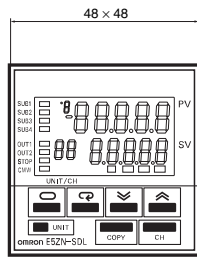

Panel Cutout Dimensions

Individual Mounting

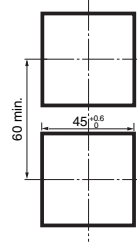

Side-by-side Mounting

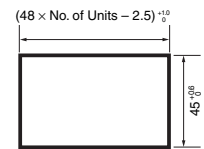

- The mounting panel thickness is 1 to 5 mm.
- Vertical side-by-side mounting is not possible. (Allow sufficient space above and below.)
- When mounting several Units, make sure that the ambient temperature specifications are not exceeded.

■ E5ZN-SDL Wiring Sockets

Front-connecting Sockets

P2CF-11 (Standard Model)

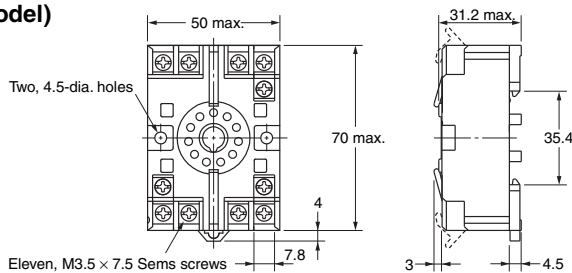
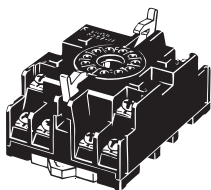

Terminal Arrangement/ Internal Connections (TOP VIEW)

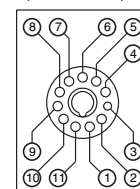

Mounting Hole Cutout Dimensions

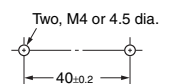

Note: DIN track mounting is also possible.

P2F-11-E (with Finger Protection)

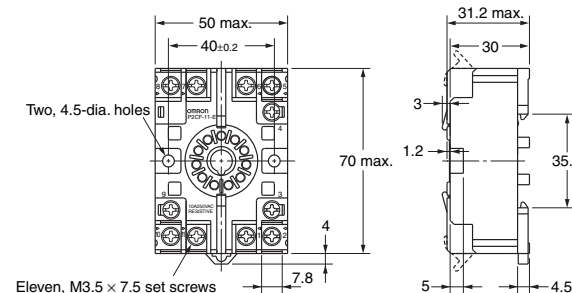
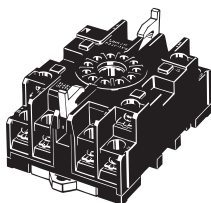

Back-connecting Sockets

P3GA-11 (Standard Model)

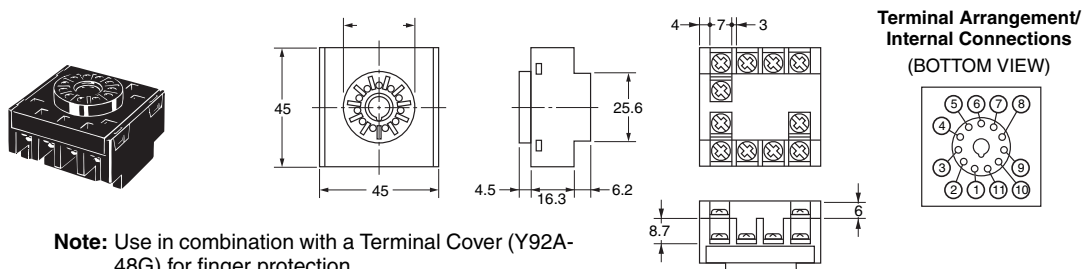

Note: Use in combination with a Terminal Cover (Y92A-48G) for finger protection.

Terminal Cover

Y92A-48G

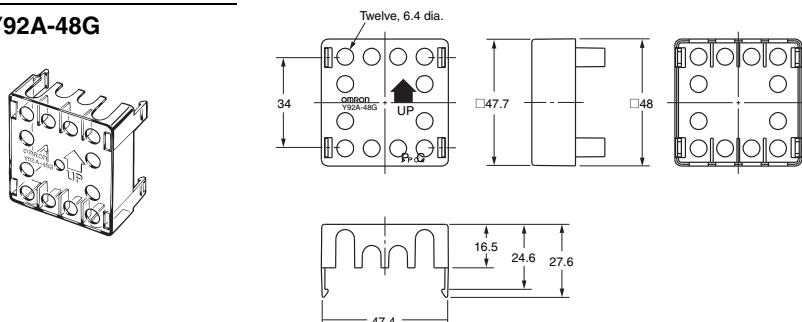

Safety Precautions

Refer to *Safety Precautions for All Temperature Controllers*.

⚠ WARNING

Provide at least one power-interruption switch to ensure that the power is OFF before wiring. Not doing so may result in electric shock.



■ Safety Precautions

Observe the following points to ensure safe operation.

- Use and store the product within the specified temperature and humidity ranges. Cool the product (e.g., using fans) where necessary.
- Do not touch the electronic components or pattern of the PCB. Hold the product by the case.
- To ensure proper heat dissipation, leave a space around the product. Do not block the product's ventilating holes.
- Use at the rated power supply voltage with the rated load.
- Be sure to connect terminals with the correct polarity.
- Perform wiring using crimp terminals of the specified size. (E5ZN-SCT□S-500: M3.0, width 5.8 mm max.; E5ZN-SDL: M3.5, width 7.2 max.)
- Be sure to use wires satisfying the following specifications for connection using bare wires.
 - Power supply terminals: AWG 22 to 14
 - Other terminals: AWG 28 to 16
 - (Length of exposed part: 6 to 8 mm)
- Do not connect anything to unused terminals.
- Ensure that the rated voltage is reached within 2 seconds of turning power ON.
- Allow 30 seconds' warm-up time.
- Install the product as far away as possible from devices that generate strong, high-frequency noise and devices that generate surges.
- Keep wiring separate from high-voltage power lines or power lines carrying large currents. Do not wire in parallel with or together with power lines.
- Install switches or circuit-breakers so that the user can turn the power OFF immediately, and indicate these accordingly.
- Do not use the product in the following locations:
 - Locations subject to dust or corrosive gases (in particular, sulfide gas and ammonia gas)
 - Locations subject to freezing or condensation
 - Locations exposed to direct sunlight
 - Locations subject to vibrations or shocks
 - Locations subject to exposure to water or oil
 - Locations subject to heat radiated directly from heating equipment
 - Locations subject to intense temperature changes
- When the Terminal Unit is separated from the Temperature Controller, under no circumstances touch the electrical components or apply shock to the Temperature Controller.
- Do not use solvents to clean the product. Use commercial alcohol.
- After wiring is completed remove the dust-protection label to allow proper heat dissipation.
- When mounting the Temperature Controller to the Terminal Unit, make sure that the hook on the side of the Temperature Controller facing the Terminal Unit is inserted properly.
- Install the DIN track vertically.

■ Precautions for Correct Use

Service Life

Use within the following temperature and humidity ranges:

- Temperature: -10 to 55°C (with no icing or condensation)
- Humidity: 25% to 85%

If the product is installed inside a control panel, the temperature around the product (and not the temperature around the control panel) must be kept below 55°C.

With electronic devices like the E5ZN, the service life will depend not only on the number of switching operations performed by the relay but also on the service life of the internal electronic components. The service life of these components depends on the ambient temperature; it will be shorter if the ambient temperature is high, and longer if the ambient temperature is low. For this reason, the service life of the product can be lengthened by keeping the inside of the E5ZN at a low temperature.

If several Units are mounted side-by-side or are arranged vertically, the heat generated may cause the internal temperature of the Units to rise, reducing service life. To prevent this, take steps to ensure that the Units are cooled, such as installing fans.

Ensure, however, that the terminals are not also cooled, otherwise correct temperature measurement will not be possible.

Measurement Accuracy

When extending the lead wires for thermocouples, use a compensating conductor appropriate for the type of thermocouple used.

When extending the lead wires for platinum resistance thermometers, use lead wires with a low resistance, and make the resistance in the 3 lead wires equal.

Make sure that the temperature sensor type and the input type of the E5ZN are the same.

Mount the E5ZN horizontally.

If significant errors occur, check that input compensation has been set correctly.

Waterproofing

The degree of protection is given below. Parts for which the degree of protection is not clearly indicated, and parts with IP□0 ratings (where □ is not 0) do not have waterproof specifications.

- Temperature Controller: IP00
- Terminal Unit: IP00

Operating Precautions

1. A time of approximately 4 s is required after the power supply is turned ON until the outputs turn ON. Take this time into consideration when the Temperature Controller is incorporated in a sequence circuit.
2. Using the product near radios, televisions, or other wireless devices may result in reception interference.

Mounting and Dismounting

- To mount using a mounting track, first hook part A (see below) onto the track and then push down on part B.

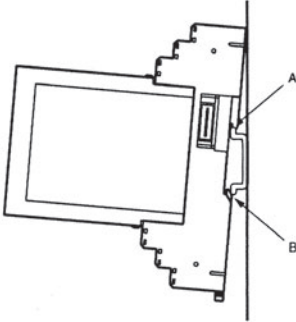

- To dismount, insert a flat-bladed screwdriver into part C, pull the hook down, and then lift the bottom part of the E5ZN upwards.

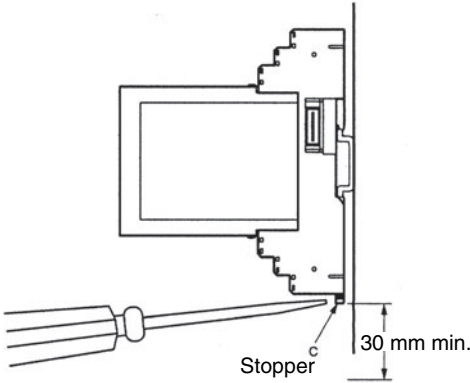

- Mount the E5ZN at least 30 mm away from other devices to ensure easy mounting and dismounting.

ALL DIMENSIONS SHOWN ARE IN MILLIMETERS.
 To convert millimeters into inches, multiply by 0.03937. To convert grams into ounces, multiply by 0.03527.

In the interest of product improvement, specifications are subject to change without notice.

Read and Understand This Catalog

Please read and understand this catalog before purchasing the products. Please consult your OMRON representative if you have any questions or comments.

Warranty and Limitations of Liability

WARRANTY

OMRON's exclusive warranty is that the products are free from defects in materials and workmanship for a period of one year (or other period if specified) from date of sale by OMRON.

OMRON MAKES NO WARRANTY OR REPRESENTATION, EXPRESS OR IMPLIED, REGARDING NON-INFRINGEMENT, MERCHANTABILITY, OR FITNESS FOR PARTICULAR PURPOSE OF THE PRODUCTS. ANY BUYER OR USER ACKNOWLEDGES THAT THE BUYER OR USER ALONE HAS DETERMINED THAT THE PRODUCTS WILL SUITABLY MEET THE REQUIREMENTS OF THEIR INTENDED USE. OMRON DISCLAIMS ALL OTHER WARRANTIES, EXPRESS OR IMPLIED.

LIMITATIONS OF LIABILITY

OMRON SHALL NOT BE RESPONSIBLE FOR SPECIAL, INDIRECT, OR CONSEQUENTIAL DAMAGES, LOSS OF PROFITS OR COMMERCIAL LOSS IN ANY WAY CONNECTED WITH THE PRODUCTS, WHETHER SUCH CLAIM IS BASED ON CONTRACT, WARRANTY, NEGLIGENCE, OR STRICT LIABILITY.

In no event shall the responsibility of OMRON for any act exceed the individual price of the product on which liability is asserted.

IN NO EVENT SHALL OMRON BE RESPONSIBLE FOR WARRANTY, REPAIR, OR OTHER CLAIMS REGARDING THE PRODUCTS UNLESS OMRON'S ANALYSIS CONFIRMS THAT THE PRODUCTS WERE PROPERLY HANDLED, STORED, INSTALLED, AND MAINTAINED AND NOT SUBJECT TO CONTAMINATION, ABUSE, MISUSE, OR INAPPROPRIATE MODIFICATION OR REPAIR.

Application Considerations

SUITABILITY FOR USE

OMRON shall not be responsible for conformity with any standards, codes, or regulations that apply to the combination of products in the customer's application or use of the products.

At the customer's request, OMRON will provide applicable third party certification documents identifying ratings and limitations of use that apply to the products. This information by itself is not sufficient for a complete determination of the suitability of the products in combination with the end product, machine, system, or other application or use.

The following are some examples of applications for which particular attention must be given. This is not intended to be an exhaustive list of all possible uses of the products, nor is it intended to imply that the uses listed may be suitable for the products:

- Outdoor use, uses involving potential chemical contamination or electrical interference, or conditions or uses not described in this catalog.
- Nuclear energy control systems, combustion systems, railroad systems, aviation systems, medical equipment, amusement machines, vehicles, safety equipment, and installations subject to separate industry or government regulations.
- Systems, machines, and equipment that could present a risk to life or property.

Please know and observe all prohibitions of use applicable to the products.

NEVER USE THE PRODUCTS FOR AN APPLICATION INVOLVING SERIOUS RISK TO LIFE OR PROPERTY WITHOUT ENSURING THAT THE SYSTEM AS A WHOLE HAS BEEN DESIGNED TO ADDRESS THE RISKS, AND THAT THE OMRON PRODUCTS ARE PROPERLY RATED AND INSTALLED FOR THE INTENDED USE WITHIN THE OVERALL EQUIPMENT OR SYSTEM.

PROGRAMMABLE PRODUCTS

OMRON shall not be responsible for the user's programming of a programmable product, or any consequence thereof.

Disclaimers

CHANGE IN SPECIFICATIONS

Product specifications and accessories may be changed at any time based on improvements and other reasons.

It is our practice to change model numbers when published ratings or features are changed, or when significant construction changes are made. However, some specifications of the products may be changed without any notice. When in doubt, special model numbers may be assigned to fix or establish key specifications for your application on your request. Please consult with your OMRON representative at any time to confirm actual specifications of purchased products.

DIMENSIONS AND WEIGHTS

Dimensions and weights are nominal and are not to be used for manufacturing purposes, even when tolerances are shown.

PERFORMANCE DATA

Performance data given in this catalog is provided as a guide for the user in determining suitability and does not constitute a warranty. It may represent the result of OMRON's test conditions, and the users must correlate it to actual application requirements. Actual performance is subject to the OMRON Warranty and Limitations of Liability.

ERRORS AND OMISSIONS

The information in this document has been carefully checked and is believed to be accurate; however, no responsibility is assumed for clerical, typographical, or proofreading errors, or omissions.

2010.6

In the interest of product improvement, specifications are subject to change without notice.

OMRON Corporation
Industrial Automation Company

<http://www.ia.omron.com/>

(c)Copyright OMRON Corporation 2010 All Right Reserved.