

# NELES

## Jamesbury™ Value-Line™ 1/4" – 2" (DN 8 – 50) series 3000 screwed NPT ball valves

Jamesbury™ Series 3000 ball valves are perfect for applications where positive, long-lasting shutoff is required. Ideal for vent, by-pass, sampling, and gauge locations, these valves provide cost-effective shutoff in a wide range of process industry, manufacturing, commercial, and OEM services. Seating options permit the handling of mild abrasives, steam, and applications with wide temperature swings.

Series 3000 valves are available in carbon steel with 316 stainless steel trim, or all 316 stainless steel. Seat options include PTFE (T) for services to 400°F (204°C); filled PTFE (M) for abrasive services, service to 500°F (260°C), steam to 250 psi (17 bar), or for applications with wide temperature fluctuations; and Acetal (R) seats for services to 2000 psi (138 bar).

### FEATURES

#### Tight Shutoff

- Polymer seats provide tight shut-off in either direction.
- Unique seat design incorporates a flexible lip which automatically compensates for wear and for changes in pressure and temperature.

#### Fire-Tite™

- Standard valves with PTFE and filled PTFE seats are Fire-Tite in accordance with API607 Edition 4.

#### Top Ground

- Valves are inherently stem-to-body grounded.

#### Lockable Handle

- Standard valves are equipped with a lockable handle that may be padlocked in either the open or closed position.

#### Rugged Unit-Body Construction

- Single-piece body minimizes potential leak paths.

#### Internal Entry Stem

- Anti-blow-out design provides inherent stem retention.



### SPECIFICATIONS

#### Valve Body Ratings

The following table shows the maximum working pressure rating of the valve body only. To determine the practical working pressure limitation of the valve, consult the seat rating chart. Working pressure rating is at -20°F to +100°F (-29°C to +38°C).

Valve Size (inches)	Body Material	
	Carbon Steel, 316 Stainless Steel	
1/4 – 2	Working pressure	2000 psi

Valve Size DN	Body Material	
	Carbon Steel, 316 Stainless Steel	
8 – 50	Working pressure	138 bar

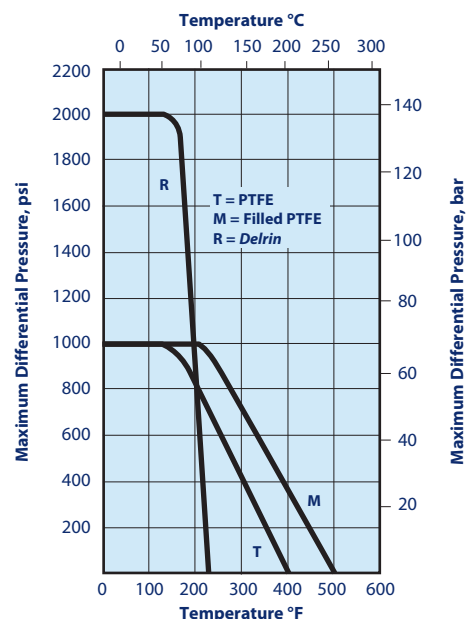

### Valve Seat Ratings

These ratings are based on differential pressure with valve ball in the fully closed position and refer to seats only. Refer to valve body ratings to be sure that all components are satisfactory.

Valves in carbon steel are suitable for service to -20°F (-29°C), valves in 316 stainless steel to -60°F (-51°C) (to -40°F (-40°C) with Acetal seats).

### Flow Data

The table at right provides flow coefficients for *Jamesbury* valves covered in this section. The  $C_v$  values represent the flow of water at +60°F through the valve in U.S. gallons per minute at a pressure drop of 1 psi. The metric equivalent,  $K_v$ , is the flow of water at 16°C through the valve in m<sup>3</sup>/hr at a pressure drop of 1 kg/cm<sup>2</sup>. To convert  $C_v$  to  $K_v$ , multiply by 0.8569.

Valve Size		$C_v$	Equiv. Length of Pipe (ft)
Inches	DN		
1/4	8	3	7.6
3/8	10	3	7.6
1/2	15	3	7.6
3/4	20	9	13.1
1	25	14	19.7
1-1/4	32	19	44.9
1-1/2	40	33	34.7
2	50	52	51.4

## ACCESSORIES

### Stem Extensions

A standard 4" (102 mm) stem extension (non-locking) is offered for Series 3000 valves for improved accessibility, particularly when used in insulated pipelines. Stem extension kits can be ordered factory mounted or shipped separately for field mounting.

Valve Size Inches	Kit Number	Approx. Dimensions, inches	
		A	H
1/4 – 3/4	SE-072	4.00	4.00
1 – 1-1/4	SE-073	5.50	4.00
1-1/2 – 2	SE-074	7.00	4.00

Valve Size DN	Kit Number	Approx. Dimensions, mm	
		A	H
8 – 20	SE-072	102	102
25 – 32	SE-073	140	102
40 – 50	SE-074	178	102

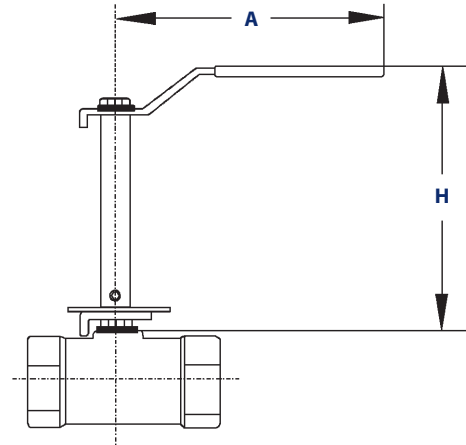

### Optional Handles

The Series 3000 ball valves described in this bulletin have two types of optional handles available, a round handle (not lockable) and a lockable oval handle. To order handles separately, specify the following part numbers.

Handle Part Numbers by Valve Size – inches	Handle Part Numbers by Valve Size – DN		
	1/4" - 3/4"	1" - 1-1/4"	1-1/2" - 2"
Round Handles	012-0785-22	012-0786-22	012-0787-22
Lockable Oval Handles	012-0794-22	012-0795-22	012-0796-22
Lockable Oval Handles (SS)	012-0794-30	012-0795-30	012-0796-30
Lockable Lever Handles	012-0802-22	012-0803-22	012-0804-22
Lockable Lever Handles (SS)	012-0802-30	012-0803-30	012-0804-30

Handle Part Numbers by Valve Size – inches	Handle Part Numbers by Valve Size – DN		
	8 - 20	25 - 32	40 - 50
Round Handles	012-0785-22	012-0786-22	012-0787-22
Lockable Oval Handles	012-0794-22	012-0795-22	012-0796-22
Lockable Oval Handles (SS)	012-0794-30	012-0795-30	012-0796-30
Lockable Lever Handles	012-0802-22	012-0803-22	012-0804-22
Lockable Lever Handles (SS)	012-0802-30	012-0803-30	012-0804-30

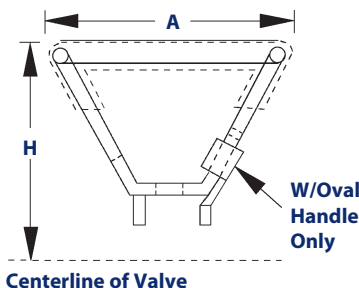

Valve Size inches	Oval and Round Handle Dimensions - inches	
	A	H
1/4 – 1/2	3.35	2.54
3/4	3.35	2.58
1	4.64	3.05
1-1/4	4.64	3.21
1-1/2	5.87	3.68
2	5.87	3.87

Valve Size DN	Oval and Round Handle Dimensions - mm	
	A	H
8 – 15	85	65
20	85	66
25	118	77
32	118	81
40	149	93
50	149	98

## DIMENSIONS

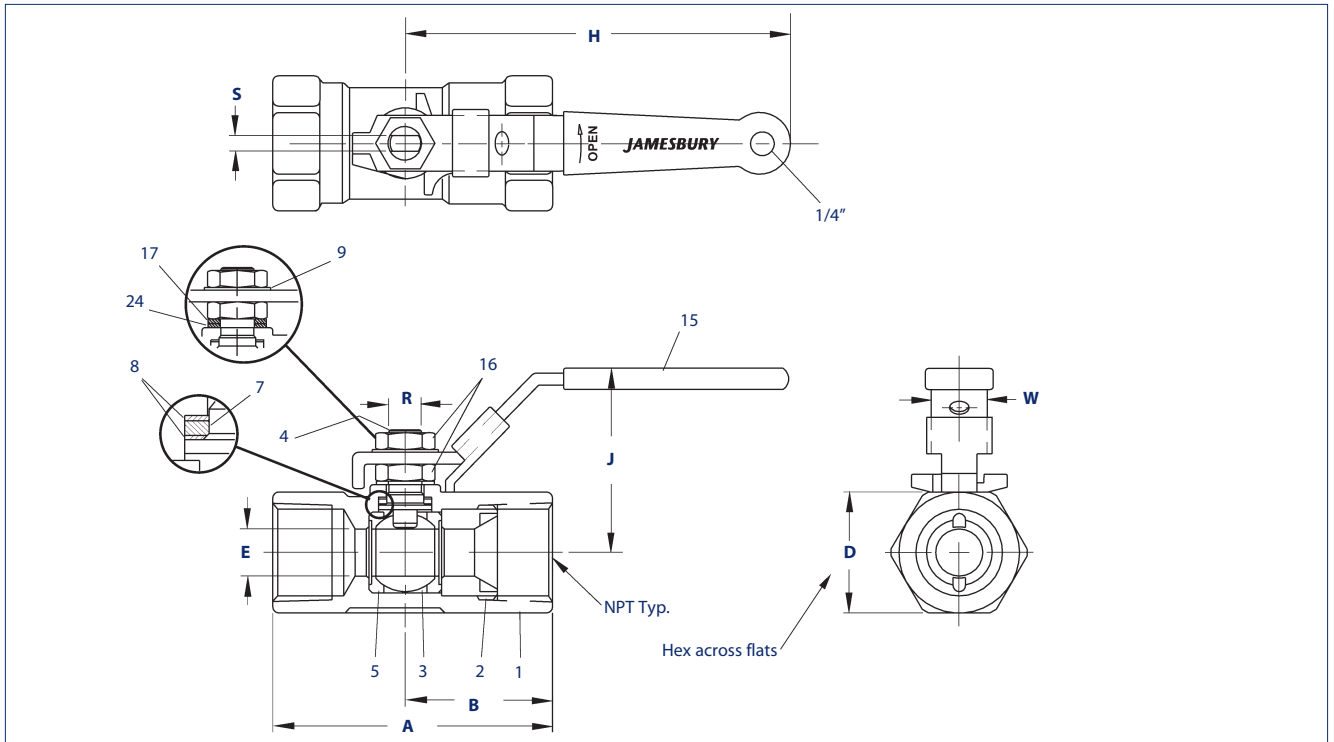

Valve Size inches	Approximate Dimensions – inches									Approx. Weight lbs
	A	B	D	E	H	J	R	S	W	
1/4	2.80	1.46	1.10	0.31	4.00	1.97	0.31	0.18	0.75	.75
3/8	2.80	1.46	1.10	0.31	4.00	1.97	0.31	0.18	0.75	.75
1/2	2.80	1.46	1.10	0.31	4.00	1.97	0.31	0.18	0.75	.75
3/4	3.05	1.62	1.26	0.50	4.00	2.01	0.31	0.18	0.75	.85
1	3.75	1.97	1.61	0.63	5.50	2.60	0.50	0.31	0.88	1.75
1-1/4	3.85	2.02	2.00	0.81	5.50	2.76	0.50	0.31	0.88	2.4
1-1/2	4.12	2.16	2.32	1.00	7.00	3.35	0.63	0.37	0.98	3.7
2	4.67	2.41	2.77	1.25	7.00	3.54	0.63	0.37	0.98	5.0

Valve Size DN	Approximate Dimensions – mm									Approx. Weight kg.
	A	B	D	E	H	J	R	S	W	
8	71	37	28	8	102	50	8	5	19	.34
10	71	37	28	8	102	50	8	5	19	.34
15	71	37	28	8	102	50	8	5	19	.34
20	77	41	32	13	102	51	8	5	19	.39
25	95	50	41	16	140	66	13	8	22	.79
32	98	51	51	21	140	70	13	8	22	1.1
40	105	55	59	25	178	85	16	9	25	1.7
50	119	61	70	32	178	90	16	9	25	2.3

## BILL OF MATERIALS AND PARTS LIST

Part Number	Part Name	Body Material	
		Carbon Steel Style 33-22	316 Stainless Steel Style 33-36
1	Body	Carbon steel type WCB	316 Stainless steel type CF8M
2	Insert	Carbon steel, coated	316 Stainless steel, coated
3	Ball	316 Stainless steel	
4	Stem	316 Stainless steel	
5	Seat	PTFE/Filled PTFE, Acetal Homopolymer	
7	Stem Seal	Graphite	
8	Stem Bearing	Filled PTFE or Acetal Homopolymer	
9	Lockwasher	Carbon steel, Stainless steel	
15	Handle	Carbon steel, Stainless steel	
16	Stem Nut	304 Stainless steel	
17	Upper Stem Washer (1" – 2" only)	316 Stainless steel	
24	Lower Stem Washer	316 Stainless steel	

**WARNING:** As the use of the valve is application specific, a number of factors should be taken into account when selecting a valve for a given application. Therefore, some of the situations in which the valves are used are outside the scope of this manual. If you have any questions concerning the use, application, or compatibility of the valve with the intended service, contact Neles for more information.

### STANDARD MATERIAL COMBINATIONS

Series 3000 valves are available in standard material combinations as shown in the following table.

Valve Type	Seat Materials		
	PTFE	Filled PTFE	Acetal
<b>Standard</b> Carbon steel body, 316 stainless steel trim	33-2236TL	33-2236ML	33-2236RL
316 stainless steel body, 316 stainless steel trim	33-3600TL	33-3600ML	33-3600RL

### HOW TO ORDER

Specify the valve size and standard material combination. The codes are explained in the tables and example below.

<b>1</b>	<b>2</b>	-	<b>3</b>	<b>4</b>	-
1/2"	33		2236	TL	

**Example:** The above example is for a 1/2" (DN 15) NPT Series 3000 ball valve constructed of carbon steel body with 316 stainless steel trim, PTFE seats and graphite seals.

<b>1</b>	<b>Size</b>
<b>inches</b>	1/4", 3/8", 1/2", 3/4", 1", 1-1/4", 1-1/2", 2"
<b>DN</b>	8, 10, 15, 20, 25, 32, 40, 50
<b>2</b>	<b>Series</b>
<b>33</b>	Series 3000
<b>3</b>	<b>Body, Ball and Stem Material</b>
<b>2236</b>	Carbon steel body with 316 stainless steel ball and stem
<b>3600</b>	316 stainless steel body, ball and stem

<b>4</b>	<b>Seat and Seal Material Options</b>
<b>TL</b>	PTFE seats with graphite seal
<b>ML</b>	Filled PTFE seats with graphite seal
<b>RL</b>	Acetal seats with graphite seal
<b>5</b>	<b>Model</b>
	Model designation is not needed for ordering purposes; <i>Jamesbury</i> will supply this information.

Subject to change without prior notice. Neles, Jamesbury and Easyflow by Neles, and certain other trademarks, are either registered trademarks or trademarks of Neles Corporation or its subsidiaries or affiliates in the United States and/or in other countries. For more information [www.neles.com/trademarks](http://www.neles.com/trademarks)

## Neles

Vanha Porvoontie 229, 01380 Vantaa, Finland.  
Tel. +358 10 417 5000.

[neles.com](http://neles.com)

Reinventing  
reliability