

111P / 233P SERIES

Single-Phase PumpSaver®

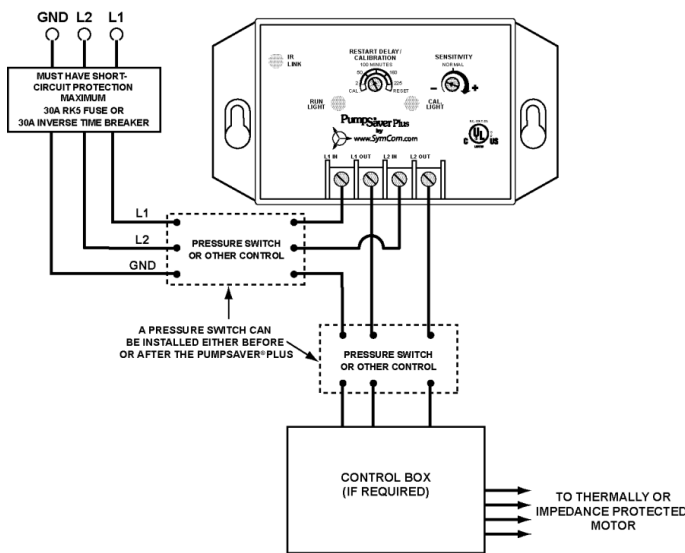

Wiring Diagram



Ordering Information

MODEL	LINE VOLTAGE	DESCRIPTION
111P	115VAC	Load Range: 1/3 - 1 hp
111P-ENCL	115VAC	111P with NEMA3R enclosure
233P	230VAC	Load Range: 1/3 - 3 hp
233P-ENCL	230VAC	233P with NEMA3R enclosure
233P-1.5	230VAC	Load Range: 1/3 - 1.5hp
233P-1.5-ENCL	230VAC	233P-1.5 with NEMA3R enclosure

Description

The 111P (115 volt, 1/3 to 1hp), 233P-1.5 (230 volt, 1/3 to 1.5hp), and 233P (230 volt, 1/3 to 3hp) single-phase PumpSaver® relays protect pumps from dry-well, dead-head, jammed impeller, rapid-cycling, and overvoltage/undervoltage, whether the pressure switch is mounted before or after our unit.

A calibration process allows the relay to be calibrated to your specific pumping application, thereby reducing the possibility of false or nuisance tripping. A proprietary microcontroller based voltage, power factor and current-sensing circuit constantly monitors for power fluctuations, overcurrent and underload conditions. When an abnormality, such as loss of suction, is detected, the relay deactivates its output relay and directly disconnects the pump motor and begins its user-selectable "Restart Delay" (dry-well recovery) timer. When the timer expires or power is removed and reapplied, the unit reactivates its output relay and allows the pump to turn back on.

An infrared LED communicates directly with a hand-held diagnostic tool called the Informer (sold separately). The Informer displays parameters including calibration points, trip points, run time and last faults.

Special considerations for pump cables larger than #10 AWG*: In some cases where larger motors are installed with deep set pumps, pump cables are used that exceed the relay's terminal size. In these conditions, a short splice of #10 AWG or #12 AWG may be a solution at the control box.

*All local, state and national electric codes should be followed when applying this solution.

NOTE: The 111P / 233P Series relays have a sensitivity adjustment for the dry-well trip point. After calibration is done, you can adjust the sensitivity for the dry-well/dead-head trip point from 70-90% of the full load. This makes the unit even more adaptable to varying pumping applications. If you have a very low producing well, you increase the sensitivity closer to the 90% mark, or if you have a very heavy producing well, you would decrease the sensitivity around the 70% mark.

Features & Benefits

FEATURES	BENEFITS
Proprietary microcontroller based circuitry	Constant monitoring of voltage, power factor, current for reliable pump protection
Onboard calibration process	Calibrates unit to your specific individual pumping application and reduces nuisance tripping
Onboard sensitivity adjustment	User adjustable sensitivity knob makes the unit more adaptable to varying pumping applications

Accessories



Informer

A hand-held diagnostic tool that uses an infrared receiver to access information which can be helpful for troubleshooting the system.

111P / 233P SERIES

Specifications

Functional Specifications

Adjustments/Settings

Overcurrent 125% of calibration point
Underload (dry-well) Adjustable (70 to 90% of calibrated run power)

Overvoltage
111P 132.5VAC
233P, 233P-1.5 265VAC

Undervoltage
111P 95VAC
233P, 233P-1.5 190VAC

**Number of restarts allowed
in a 60-sec. period
(rapid-cycling)** 4

Trip Delay Times

Overcurrent 5 seconds
Dry-well 4 seconds

Restart Delay Times

Over/Undervoltage 2 seconds
All other faults Manual, 2-225 Minutes

Input Characteristics

Supply Voltage
111P 115VAC
233P-1.5, 233P 230VAC

Load Range:
111P $\frac{1}{3}$ – 1 hp
233P-1.5 $\frac{1}{3}$ – 1.5 hp
233P $\frac{1}{3}$ – 3 hp

Frequency 50/60Hz (*Note: 50Hz will increase all delay
timers by 20%*)

Output Characteristics

Output Contact Rating-SPST

111P 1hp@120VAC (16 amps max.)
233P-1.5 1.5hp@240VAC (10 amps max.)
233P 3hp@240VAC (17 amps max.)

General Characteristics

Operating Temperature -40° to 55° C (-40° to 131° F)
Maximum Input Power 5 W
Wire Gauge Solid or Stranded 10 - 22AWG
Terminal Torque 13 in.-lbs.

Safety Marks

cULus Listed

Dimensions

UL508, C22.2 No. 14
H 73.66 mm (2.9"); **W** 133.35 mm (5.25");
D 73.99 mm (2.913")

Weight

14 oz.

Mounting Methods

#8 screws