

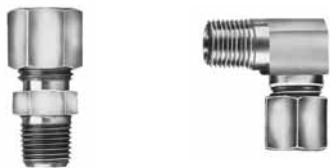

### Divider Valve Mounting Accessories

| Model No. | Description   |
|-----------|---|
| 246416    | Valve mounting bracket  |
| 51304     | ¼" nylon locknut for valve mounting                                 |
| 247023    | Grade 8, ¼" valve mounting bolt                                     |
| 239499    | Template for divider valve mounting (6, 8, 10 and 12 outlet valves) |
| 252807    | Valve mounting block for welding                                    |
| 249987    | 6mm bolt to be used with the 252807                                 |
| 272569    | Lock washer for valve mounting                                      |



### Standard Compression Fittings for Steel or Nylon Tubing

| Model No. | Description                            |
|-----------|--|
| 241290    | ¼" tube x ⅛" NPT male straight fitting |
| 241293    | ¼" tube x ⅛" NPT male 90° fitting      |



### Divider Valve Outlet Adapters for ¼" O.D. Steel or Nylon Tubing Compression-Style With Check Valve

| Model No.   | Description      |
|-------------|------------------|
| 68462       | Ferrule ¼"       |
| 404-22602-1 | Compression nut  |
| 504-31606-3 | Check valve body |
| 404-22581-2 | Ferrule          |



### Divider Valve Outlet Adapters for ¼" O.D. Steel or Nylon Tubing Compression-Style Without Check Valve

| Model No.   | Description                       |
|-------------|-----------------------------------|
| 404-20236-4 | Compression nut                   |
| 404-23668-1 | Compression nut (stainless steel) |
| 404-22581-2 | Ferrule                           |



### Divider Valve Outlet Adapters for ⅛" I.D. Hose

| Model No.   | Description  |
|-------------|--|
| 404-22581-2 | Ferrule  |
| 239857      | Valve outlet adapter with check (⅛" NPT female)    |
| 239959      | Valve outlet adapter without check (⅛" NPT female) |



### For SSVM Valves—Compression Fitting

| Model No.   | Description      | Material | Feed Line Connection   |
|-------------|------------------|----------|------------------------|
| 13112       | Compression nut  | Brass    | ⅛" Steel or Nylon Tube |
| 419-22990-1 | Adapter          |          |                        |
| 419-22618-2 | Ferrule          |          |                        |
| 519-30583-1 | Check valve body |          |                        |

**NOTE:** Quicklub® adapters without check valves are for use in oil systems with open tube (minimal backpressure). Quicklub adapters with check valves are for use in all automated systems.

**Zerk-Lock™ and Quicklinc® Make Connecting Fast**

Quicklinc line connectors and adapters link metering valves and flexible lubrication lines. Outlet adapters with check valves are used in automated systems, while models without a check valve are used in manual systems—called single point kits—where a divider valve connected to several lubrication points is fed with a grease gun.

The Quicklinc tube splicer union is a great way to fix a broken line without replacing the whole line. Just clean the line ends, plug them into the connector and the line's repaired.

Quicklinc lube point connectors are ideal when fittings can be removed easily. All three varieties—straight, 90-degree elbow and elbow swivel—connect much faster than using a typical screw connector, which requires assembly of four components.

Zerk-Lock is Lincoln's other great time-saving connector. When removing a fitting is not practical, the Zerk-Lock grease fitting adapter is the answer. It connects any 1/8-inch male tube adapter directly to a grease fitting. Even when a fitting is self-tapered or pressed in, there's no need to drill it out and tap new threads with Zerk-Lock—a tremendous time saving.

Quicklinc and Zerk-Lock are designed to work well together. It's as simple as:

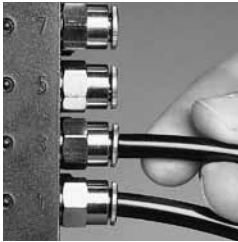

1. Install a Quicklinc into the divider valve and insert the line



2. Place a Zerk-Lock onto the fitting



3. Seal and tighten Zerk-Lock using a hammer and staking tool



4. Then thread a Quicklinc completely into the Zerk-Lock



5. And plug the tube into the Quicklinc adapter



**Quicklinc Push-In Style Fittings for Nylon Tubing**

| Model No. | Description                                  |
|-----------|--|
| 244047    | 1/4" tube x 1/8" NPT male straight fitting   |
| 244048    | 1/4" tube x 1/8" NPT male 90° fitting        |
| 243699    | 1/4" tube x 1/8" NPT male 90° swivel fitting |
| 244053    | 1/4" tube x 1/4 -28 male 90° swivel fitting  |
| 244054    | 1/4" tube x 1/4 -28 male 90° fitting         |
| 244055    | 1/4" tube x 1/4 -28 male straight fitting    |
| 244056    | 1/4" tube x 6x1 mm male 90° fitting          |
| 244057    | 1/4" tube x 6x1 mm straight fitting          |
| 244058    | 1/4" tube x 1/4" tube splicer union          |



**Divider Valve Outlet Adapters for 1/4" O.D. Nylon Tubing Quicklinc Push-In Style**

| Model No. | Description                                     |
|-----------|---|
| 244883    | Valve outlet fitting with check M10x1 thread    |
| 244884    | Valve outlet fitting without check M10x1 thread |



**Divider Valve Outlet & Inlet Adapters for 1/8" I.D. Hose Quicklinc Push-In Style with Check**

| Model No. | Description   |
|-----------|---|
| 272658    | Valve outlet fitting with check. Use with 272401 and 272394 hose stud. M10x1 thread |
| 272659    | 1/8" NPT male straight fitting. Use with 272401 and 272394 hose stud.               |



IMPORTANT: Use the valve adapters for connecting the 1/8" high pressure hose (incl. hose stud with groove) to the main divider valve. The collet of the adapter is not knurled and has a wide collar.



| Model No.   | Description                      |
|-------------|----------------------------------|
| 432-24313-1 | Protective Quicklinc rubber boot |



### Divider Valve Outlet Closure Plug

| Model No.   | Description   |
|-------------|---|
| 303-17499-3 | Valve outlet closure plug (gasket not required)           |
| 303-19346-2 | Stainless steel outlet closure plug (gasket not required) |

### 1/8" Supply and Feed Line Hose

| Min. Burst             | Lube Working Pressure | Nominal Size |       | Minimum Bending Radius | Construction                                     | Temp.           |
|------------------------|-----------------------|--------------|-------|------------------------|--|-----------------|
|                        |                       | ID           | OD    |                        |  |                 |
| 10,000 psig<br>690 bar | 4000 psig<br>276 bar  | 1/8"         | 5/16" | 3 1/2"                 | Nylon Tube<br>Dacron Braid<br>Polyurethane Cover | -40°F to +212°F |

| Model No. | Description (1/8" ID hose)  |
|-----------|---|
| 241286    | 26 ft. (7.92 m) coil grease filled  |
| 241287    | 35 ft. (10.66 m) coil grease filled   |
| 241288    | 40 ft. (12.19 m) coil grease filled   |
| 252717    | 200 ft (60.96 m) coil non-grease filled                                     |
| 277226    | 2250 ft. (685.8 m) spool non-grease filled                                  |
| 276395    | 40 ft. (12.19 m) grease filled with quick wrap protection installed on hose |

### Hose Ends for Use with Quickline Fittings for 1/8" ID Hose

| Model No. | Description                                  |
|-----------|--|
| 272394    | Hose stud, 90° (to be used with 272427)      |
| 272401    | Hose stud, straight (to be used with 272427) |
| 272427    | Threaded sleeve                              |
| 274238    | Stainless steel hose stud sleeve             |
| 274239    | Stainless steel straight hose                |

### Hose Ends for 1/8" I.D. Hose

| Model No. | Description   |
|-----------|---|
| 241289    | 1/8" NPT swedge on hose stud (Requires swedging tool)                 |
| 246002    | 1/8" NPT field installable hose coupling (swedging tool not required) |
| 276954    | 1/8" NPT swedge on hose fitting with swivel (requires swedging tool)  |

### Hose End Connecting Tools

| Model No. | Description  |
|-----------|--|
| 241238    | Hose Swedging Tool                                 |
| 274062    | Hand vise for quick connect and reusable hose ends |

### Feed Line Nylon Tubing

| Model No. | Description                             | O.D. In.   | Wall Thickness in. / mm | Working Pressure |      | Minimum Bending Radius | Temp.           |
|-----------|---|------------|-------------------------|------------------|------|------------------------|-----------------|
|           |   |            |                         | psig             | bar  |                        |                 |
| 242025    | 25 ft./7.6 m coil grease filled         | 1/4" black | .050 / 1.27             | 625              | 42.5 | .875 / 22.2            | -65°F to +150°F |
| 242050    | 50 ft./15.2 m coil grease filled        |            |                         |                  |      |                        |                 |
| 62357     | 100 ft./30.5 m coil non-grease filled   |            |                         |                  |      |                        |                 |
| 247022    | 500 ft./152.40 m coil non-grease filled |            |                         |                  |      |                        |                 |
| 274047    | 25 ft./7.6 m coil grease filled         | 1/4" grey  | .062 / 1.575            | 500              | 34.5 | 0.5 / 12.7             | -65°F to +200°F |
| 274048    | 50 ft./15.2 m coil grease filled        |            |                         |                  |      |                        |                 |
| 274049    | 100 ft./30.5 m coil non-grease filled   |            |                         |                  |      |                        |                 |
| 274050    | 500 ft./152.4 m coil non-grease filled  |            |                         |                  |      |                        |                 |

**NOTE:** Burst pressure 2500 psi (172 bar)



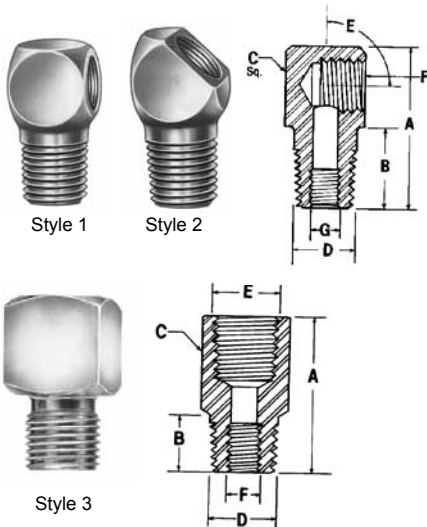

### Pipe Thread Adapters

| Model No. | Style | A                | B                | C                    | D          | E      | F      |
|-----------|-------|------------------|------------------|----------------------|------------|--------|--------|
| 13129     | 1     | 1½               | ⅞                | ⅝                    | ¼ NPTF     | 90°    | ⅞ NPTF |
| 20024     | 3     | ⅞                | ⅝ <sub>16</sub>  | ½ hex                | ¼-28 Taper | ⅞ NPSF | —      |
| 20026     | 1     | 1⅜ <sub>16</sub> | ⅝ <sub>16</sub>  | ½ sq.                | ¼-28 Taper | 90°    | ⅞ PTF  |
| 20028     | 2     | 1                | 1⅝ <sub>32</sub> | ½ sq.                | ⅞ PTF      | 45°    | ⅞ PTF  |
| 20029     | 1     | 1                | 1⅝ <sub>32</sub> | ½ sq.                | ⅞ PTF      | 90°    | ⅞ PTF  |
| 247616    | 2     | 1                | 1⅜ <sub>32</sub> | ½ sq.                | ¼-28 Taper | 45°    | ⅞ PTF  |
| 276631    | 1     | 1                | ⅝                | ½ sq.                | ¼-28 Taper | 90°    | ⅞ NPTF |
| 20012     | 1     | 1⅝ <sub>16</sub> | ⅝                | 1⅜ <sub>16</sub> sq. | ¼ NPT      | 90°    | ¼ NPT  |

### Steel Tubing

| Model No. | Size (O.D. x Wall) |       |             | Working Pressure    | Type |
|-----------|--------------------|-------|-------------|---------------------|------|
|           | O.D.               | Wall  | Length      |                     |      |
| 62175     | ⅝                  | .020" | 25 ft/7.6 m | 4400 psig / 300 bar | Coil |

### Nylon Tubing

| Model No. | Size (O.D. x Wall) |       |               | Working Pressure    | Minimum Bending Radius |
|-----------|--------------------|-------|---------------|---------------------|------------------------|
|           | O.D.               | Wall  | Length        |                     |                        |
| 62256     | ⅝"                 | .026" | 25 ft/7.6 m   | 625 psig / 42.5 bar | .375"                  |
| 62278     |                    |       | 100 ft/30.5 m |                     |                        |
| 62956     |                    |       | 500 ft/152 m  |                     |                        |

### Grease Fittings

| Model No. | Description                                |
|-----------|--|
| 700506    | ⅝" NPT threaded straight leakproof fitting |
| 242125    | Plastic grease fitting cap                 |

### Fittings, Adapters and Installation Accessories

| Model No. | Description  |
|-----------|--|
| 10130     | ⅝" NPT male x ⅝" NPT male nipple                         |
| 10181     | ⅝" NPT male x ⅝" NPT female adapter, 1⅜" long            |
| 10182     | ⅝" NPT male x ⅝" female adapter, 1⅝ <sub>16</sub> " long |
| 14562     | 2 outlet ⅝" NPT x ⅝" NPT junction block                  |
| 14563     | 4 outlet ⅝" NPT x ⅝" NPT junction block                  |
| 81583     | Junction Block, ⅝" NPT                                   |
| 14570     | Anchor block   |
| 276407    | ⅝" NPT male x ⅝" NPT female x ⅝" NPT female              |
| 10461     | ¼" NPT male x ⅝" NPT female reducing bushing             |

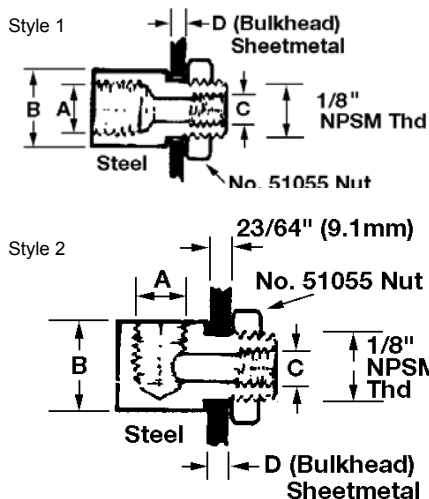

### Bulkhead Adapters

| Model No. | Style              | A      | B            | C      | D                          |
|-----------|--------------------|--------|--------------|--------|----------------------------|
| 13154     | 1                  | ⅝" PTF | ½" / 12.7 mm | ¼" -28 | ⅜ <sub>16</sub> " / 4.8 mm |
| 14054     | 1                  | ⅝" PTF | ½" / 12.7 mm | ¼" -28 | ¼" / 6.4 mm                |
| 13155     | 2                  | ⅝" PTF | ½" / 12.7 mm | ¼" -28 | ⅜ <sub>16</sub> " / 4.8 mm |
| 244225    | 1                  | ⅝" NPT | ⅞" hex       | ⅝" NPT | ⅞"                         |
| 51055     | ⅝" N.P.S.M. thread |        |              |        |                            |



### Metric Adapters\*

| Model No.   | Description   |
|-------------|---|
| 20042       | M6X1 male x 1/8" NPSF female straight                     |
| 20043       | M6X1 male x 1/8" NPSF female 90°                          |
| 244201      | 1/8" BSPT male x 1/8" NPT female thread                   |
| 304-19166-1 | M6X1 male x 1/4" - 28 SAE female                          |
| 304-19165-1 | M8X1 male x 1/4" - 28 SAE female                          |
| 304-19164-1 | M10X1 male x 1/4" - 28 SAE female                         |
| 241650      | 1/8" BSPT male x 1/8" NPT female thread - stainless steel |
| 273482      | M8X1 male x 1/8" NPT female straight                      |
| 277307      | M8X1 female x M8X1.25 male 90°                            |

\* Contact Lincoln for a complete metric Quicklub catalog.

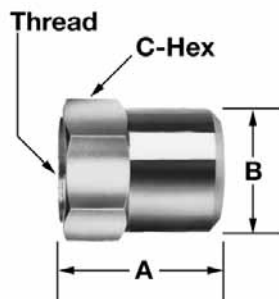

### Zerk-Lock™ Grease Fitting Adapter

Connects any 1/8" NPTF male tube adapter directly to a standard grease fitting. Aluminum, carbon steel construction; fluorocarbon elastomer seal.

| Model No. | Thread           | Dimensions  |             |                   |
|-----------|------------------|-------------|-------------|-------------------|
|           |                  | A<br>in./mm | B<br>in./mm | C-Hex<br>in. / mm |
| 270784    | 1/8" NPSL Female | .625 / 15.9 | .500 / 12.7 | .500 / 12.7       |

**Note:**

Zerk-Lock, with a straight female thread, is designed to accept a tube connector with a tapered male thread. This tapered to straight thread engagement is required for secure seal.

| Model No. | Description                                   |
|-----------|---|
| 247615    | Staking tool for the 270784 Zerk Lock fitting |



### Swivels

| Model No. | Description                                     |
|-----------|---|
| 91048     | 1/8" NPT male x 1/8" NPT female 90° swivel      |
| 91308     | 1/8" NPT male x 1/8" NPT female straight swivel |

### Street Tee

| Model No. | Description                                       |
|-----------|---|
| 276407    | 1/8" NPT male x 1/8" NPT female x 1/8" NPT female |

### Adapter Unions

| Model No. | Description  |
|-----------|--|
| 66649     | 1/8" NPT male x 1/8" NPT female swivel adapter union |

### Installation/Assembly Tools

| Model No.   | Description  |
|-------------|--|
| 226-12508-5 | Plastic Tube & Hose Cutter                         |
| 226-13095-7 | Replacement Blade                                  |
| 241238      | Hose Swedging Tool                                 |
| 274062      | Hand vise for quick connect and reusable hose ends |
| 532-31847-1 | Tool for Loosening Quickline-Type Fittings         |
| 276424      | Quicklub Spare Parts Kit                           |



### Quick Wrap for Line Bundling and Protection

Quick split wrap makes bundling and protecting lube lines fast. It's as simple as:

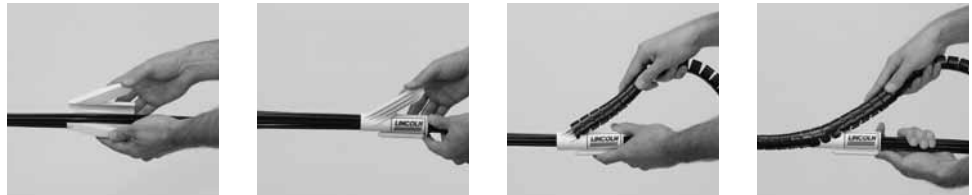

1. Place installation tool around group of lines
2. Slide Quick Wrap onto line bundle

| Model No. | Description                 | Installation Tool Required | Approx. Number of 1/4" Tube | Approx. Number of 1/8" ID Hose |
|-----------|-----------------------------|----------------------------|-----------------------------|--------------------------------|
| 276389    | 5/8" Quick Wrap (164' roll) | 276634                     | 2 - 5                       | 2 - 3                          |
| 276390    | 3/4" Quick Wrap (100' roll) | 276634                     | 5 - 7                       | 3 - 4                          |
| 276391    | 1" Quick Wrap (65' roll)    | 276635                     | 7+                          | 4+                             |



### System Finishing Accessories

| Model No. | Description  |
|-----------|--|
| 241110    | Feed line bundling spiral wrap (10 ft. / 3 m length)       |
| 241120    | Feed line bundling spiral wrap (20 feet/6m of spiral wrap) |
| 276693    | 300 feet of spiral wrap                                    |
| 241055    | Nylon ties (50 count poly bag) 7" / 177.8 m length         |
| 241054    | Nylon ties (100 count poly bag) 7" / 177.8 m length        |
| 274097    | 20 feet/6m of 3/8" convoluted loom/split wrap              |
| 274098    | 20 feet/6m of 1/2" convoluted loom/split wrap              |
| 274099    | 20 feet/6m of 5/8" convoluted loom/split wrap              |



### Pump Mounting Bracket and Hardware for 203 Series and QLS 300 & 400 Series Pumps

| Model No. | Description   |
|-----------|---|
| 249520    | Pump mounting bracket for 203/301/401/653 Series pumps                |
| 249209    | 12 mm x 1 1/2" long grade 8 bolt for 249520 pump bracket (2 required) |
| 274820    | Pump and primary valve mounting bracket                               |

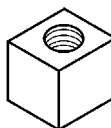

### Stand Offs for Mounting SSV Valves, P-Clamps and Angle Iron

| Model No. | Description   |
|-----------|---|
| 252807    | Valve mounting block for welding                        |
| 249987    | 6mm bolt to be used with the 252807                     |
| 249850    | 12mm round stand off                                    |
| 270928    | 12mm square stand off                                   |
| 249848    | 12mm x 5/8" long bolt to be used with 249850 and 270928 |
| 249851    | 10mm round stand off                                    |
| 249849    | 10mm x 5/8" long bolt to be used with 249851            |

These kits are designed to service up to 12 points from a single grease fitting utilizing our 12-point SSV series divider valve. The kits, which are available with or without a grease gun, include all componentry required to install the system. Kits are available primed with NLGI #2 grease or non-filled if a specific grade or type of grease is to be used.

These kits effectively replace the concept of using grease fittings mounted to a central manifold with a system that delivers precise amounts of lubricant, fully monitored with the divider valve's indicator pin. Kits include 100' ¼" nylon tubing, 12 straight Quicklinc® tube fittings, 12 Zerk-Lock™ adapters, mounting clips and hardware.

## Quicklub Centralized Lubrication Kits

Single point kits contain all items required to install a system on your machinery, including a complete installation/service manual. The selection chart describes the models available to meet your specific needs.

| Model No. | Selection Chart Description                               | Tubing     |
|-----------|---|------------|
| 87311     | Kit with single fitting for use with portable grease gun. | Non-filled |
| 87312     |   | Pre-filled |
| 87412     | Complete kit with grease gun for permanent mounting.      | Pre-filled |



**Trailer Kits—Unassembled**

| Model No. | Description            |
|-----------|------------------------|
| 239406    | 6-point manual QL kit  |
| 239408    | 8-point manual QL kit  |
| 239410    | 10-point manual QL kit |
| 239412    | 12-point manual QL kit |
| 239418    | 18-point manual QL kit |

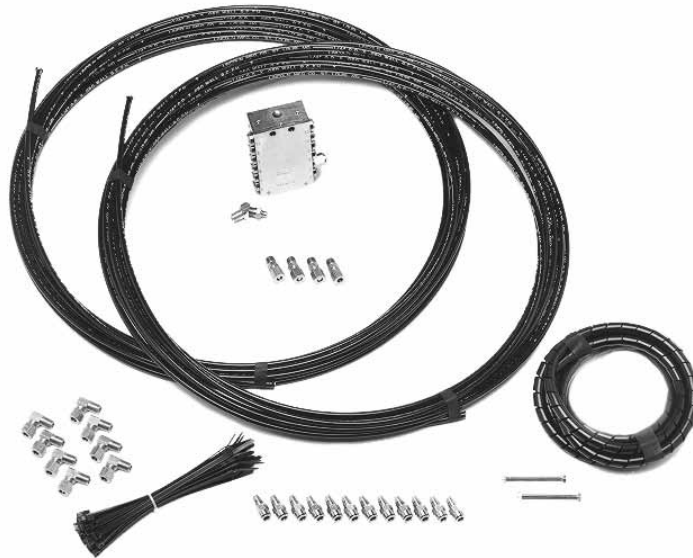

**Trailer Kits—Preassembled**

| Model No. | Description                        |
|-----------|------------------------------------|
| 244512    | 12-point manual QL kit—tandem axle |



**Note:** Above referenced kits require purchase of electric grease pump (see Pump section of this catalog) when fully automated system is desired.



**Tractor/Truck Kits**  
**Unassembled Kits**

| Description     | Manual Kits | Automated Kits                     |
|-----------------|-------------|------------------------------------|
| 24-point QL kit | 241324      | 241124 (includes 241324 and 94012) |
| 28-point QL kit | 241328      | 241128 (includes 241328 and 94012) |
| 32-point QL kit | 241332      | 241132 (includes 241332 and 94012) |
| 33-point QL kit | 241333      | 241133 (includes 241333 and 94012) |

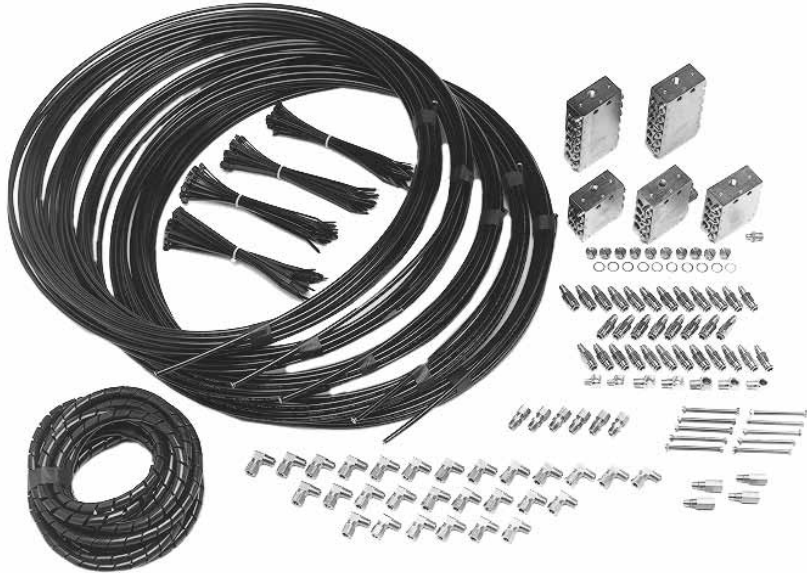

**Preassembled Manual Kits**

| Model No. | Description                      |
|-----------|----------------------------------|
| 247232    | 32-point manual preassembled kit |



**Note:** Above referenced kits require purchase of electric grease pump (see Pump section of this catalog) when fully automated system is desired.

| Model No.   | Page No. | Model No. | Page No. | Model No.   | Page No. | Model No.   | Page No. |
|-------------|----------|-----------|----------|-------------|----------|-------------|----------|
| 674         | 24       | 241324    | 34       | 272633      | 23       | 304-19614-1 | 9, 23    |
| 10130       | 29       | 241328    | 34       | 272634      | 23       | 404-20236-4 | 26       |
| 10181       | 29       | 241332    | 34       | 272643      | 23       | 404-22581-2 | 26       |
| 10182       | 29       | 241333    | 34       | 272658      | 27       | 404-22602-1 | 26       |
| 10461       | 29       | 241650    | 4, 30    | 272659      | 27       | 404-23668-1 | 26       |
| 13112       | 26       | 242025    | 28       | 273422      | 23       | 419-22618-2 | 26       |
| 13129       | 29       | 242050    | 28       | 273425      | 23       | 419-22990-1 | 26       |
| 13154       | 29       | 242125    | 29       | 273426      | 23       | 432-24313-1 | 27       |
| 13155       | 29       | 243699    | 27       | 273482      | 30       | 444-70490-1 | 14       |
| 14054       | 29       | 244047    | 27       | 273921      | 24       | 444-70491-1 | 14       |
| 14562       | 29       | 244048    | 27       | 274047      | 28       | 504-31606-3 | 26       |
| 14563       | 29       | 244053    | 27       | 274048      | 28       | 51055       | 29       |
| 14570       | 29       | 244054    | 27       | 274049      | 28       | 51304       | 26       |
| 20012       | 29       | 244055    | 27       | 274050      | 28       | 519-30583-1 | 26       |
| 20024       | 29       | 244056    | 27       | 274062      | 28, 30   | 519-34271-2 | 23       |
| 20026       | 29       | 244057    | 27       | 274097      | 31       | 519-34271-7 | 23       |
| 20028       | 29       | 244058    | 27       | 274098      | 31       | 519-34271-8 | 23       |
| 20029       | 29       | 244201    | 30       | 274099      | 31       | 519-34339-3 | 23       |
| 20042       | 30       | 244225    | 29       | 274149      | 23       | 519-34339-4 | 23       |
| 20043       | 30       | 244512    | 33       | 274238      | 28       | 532-31847-1 | 30       |
| 226-12508-5 | 30       | 244883    | 27       | 274239      | 28       | 538-36763-1 | 24       |
| 226-13095-7 | 30       | 244884    | 27       | 274820      | 31       | 538-36763-4 | 24       |
| 226-14105-5 | 23       | 246002    | 28       | 274847      | 23       | 538-36763-5 | 24       |
| 236-10580-1 | 23       | 246322    | 24       | 276389      | 31       | 544-32022-1 | 14       |
| 236-14261-9 | 23       | 246416    | 26       | 276390      | 31       | 544-32023-1 | 14       |
| 237-13381-2 | 23       | 247022    | 28       | 276391      | 31       | 544-32695-1 | 14       |
| 237-13381-3 | 23       | 247023    | 26       | 276395      | 28       | 544-32696-1 | 14       |
| 239406      | 33       | 247232    | 34       | 276407      | 29, 30   | 544-32957-2 | 14       |
| 239408      | 33       | 247615    | 30       | 276409      | 24       | 549-34254-1 | 6        |
| 239410      | 33       | 247616    | 29       | 276424      | 30       | 549-34254-2 | 6        |
| 239412      | 33       | 249010    | 4        | 276631      | 29       | 549-34254-3 | 6        |
| 239418      | 33       | 249209    | 31       | 276634      | 31       | 549-34254-4 | 6        |
| 239499      | 26       | 249520    | 31       | 276635      | 31       | 549-34254-5 | 6        |
| 239857      | 26       | 249848    | 31       | 276693      | 31       | 549-34254-6 | 6        |
| 239959      | 26       | 249849    | 31       | 276954      | 28       | 549-34254-7 | 6        |
| 241052      | 24       | 249850    | 31       | 277057      | 24       | 549-34254-8 | 6        |
| 241053      | 24       | 249851    | 31       | 277059      | 24       | 549-34254-9 | 6        |
| 241054      | 31       | 249987    | 26, 31   | 277226      | 28       | 549-34255-1 | 6        |
| 241055      | 31       | 252717    | 28       | 277307      | 30       | 600-26875-2 | 24       |
| 241110      | 31       | 252807    | 26, 31   | 303-16118-1 | 6        | 600-26876-2 | 8        |
| 241116      | 34       | 256276    | 24       | 303-16119-1 | 6        | 600-26876-2 | 24       |
| 241120      | 31       | 270784    | 30       | 303-16120-1 | 6        | 600-26877-2 | 24       |
| 241124      | 34       | 270864    | 8, 23    | 303-16121-1 | 6        | 600-28750-1 | 23, 24   |
| 241128      | 34       | 270928    | 31       | 303-16122-1 | 6        | 600-29110-1 | 24       |
| 241129      | 34       | 271374    | 23       | 303-16123-1 | 6        | 600-29185-1 | 24       |
| 241132      | 34       | 271924    | 22       | 303-16124-1 | 6        | 600-29304-1 | 24       |
| 241133      | 34       | 271925    | 22       | 303-16125-1 | 6        | 619-26396-2 | 4        |
| 241238      | 28, 30   | 271926    | 22       | 303-16126-1 | 6        | 619-26398-2 | 4        |
| 241286      | 28       | 271927    | 22       | 303-16127-1 | 6        | 619-26646-2 | 4        |
| 241287      | 28       | 272394    | 27, 28   | 303-17499-3 | 28       | 619-26648-2 | 4        |
| 241288      | 28       | 272401    | 27, 28   | 303-19346-2 | 28       | 619-26650-1 | 5        |
| 241289      | 28       | 272427    | 28       | 304-19164-1 | 30       | 619-26651-3 | 5        |
| 241290      | 26       | 272569    | 26       | 304-19165-1 | 30       | 619-26653-1 | 5        |
| 241293      | 26       | 272632    | 23       | 304-19166-1 | 30       | 619-26654-3 | 5        |

| Model No.   | Page No. | Model No.   | Page No. | Model No.     | Page No. | Model No.     | Page No. |
|-------------|----------|-------------|----------|---------------|----------|---------------|----------|
| 619-26764-1 | 5        | 644-46174-4 | 11       | 80895         | 24       | P311 31211154 | 19       |
| 619-26765-3 | 5        | 644-46278-1 | 8        | 81583         | 29       | P311 31411110 | 20       |
| 619-26844-1 | 4        | 644-46278-3 | 8        | 85414         | 22       | P311 31411154 | 19       |
| 619-26845-2 | 4        | 649-29535-1 | 6        | 85424         | 22       | P311 42611114 | 19       |
| 619-26848-1 | 5        | 649-29536-1 | 6        | 85425         | 22       | P311 42811114 | 19       |
| 619-26849-2 | 5        | 649-29537-1 | 6        | 85429         | 22       | P311 61211154 | 19       |
| 619-27121-1 | 4        | 649-29538-1 | 6        | 87311         | 32       | P311 61411110 | 20       |
| 619-27122-1 | 4        | 649-29539-1 | 6        | 87312         | 32       | P311 61411154 | 19       |
| 619-27472-1 | 4        | 649-29540-1 | 7        | 87412         | 32       | P311 62611114 | 19       |
| 619-27474-1 | 4        | 649-29541-1 | 7        | 85830         | 24       | P311 62811114 | 19       |
| 619-27476-1 | 4        | 649-29542-1 | 7        | 91048         | 30       | P311 91211154 | 19       |
| 619-27478-1 | 4        | 649-29543-1 | 7        | 91308         | 30       | P311 91411154 | 19       |
| 619-28899-1 | 4        | 649-29544-1 | 7        | 94012         | 8        | P311 92611114 | 19       |
| 619-28900-1 | 4        | 649-29545-1 | 6        | 94024         | 8        | P311 92811114 | 19       |
| 619-28901-1 | 4        | 649-29546-1 | 6        | 94212         | 8        | P401 31202574 | 15       |
| 619-28902-1 | 4        | 649-29547-1 | 6        | 94222         | 9        | P401 31401110 | 16       |
| 619-29067-1 | 4        | 649-29548-1 | 6        | 94223-12      | 10       | P401 31402574 | 15       |
| 619-29400-1 | 4        | 649-29549-1 | 6        | 94223-AC      | 10       | P401 42601114 | 15       |
| 619-29401-1 | 4        | 649-29550-1 | 7        | 94223         | 10       | P401 42801114 | 15       |
| 619-36732-1 | 5        | 649-29551-1 | 7        | 94224         | 8        | P401 61202574 | 15       |
| 619-36732-2 | 5        | 649-29552-1 | 7        | 94412         | 8        | P401 61401110 | 16       |
| 619-77254-1 | 4        | 649-29553-1 | 7        | 94412LDL      | 8        | P401 61402574 | 15       |
| 62175       | 29       | 649-29554-1 | 7        | 94422         | 9        | P401 62601114 | 15       |
| 62256       | 29       | 649-29627-1 | 6        | 94423-12      | 10       | P401 62801114 | 15       |
| 62278       | 29       | 649-29628-1 | 6        | 94423-AC      | 10       | P401 91202574 | 15       |
| 62357       | 28       | 649-29629-1 | 6        | 94423         | 10       | P401 91401110 | 16       |
| 624-28894-1 | 23       | 649-29630-1 | 6        | 94423LDL      | 10       | P401 91402574 | 15       |
| 624-28895-1 | 23       | 649-29631-1 | 7        | 94424         | 8        | P401 92601114 | 15       |
| 624-28931-1 | 23       | 649-29632-1 | 7        | 94434LDL      | 13       | P401 92801114 | 15       |
| 62956       | 29       | 649-29633-1 | 7        | 94812         | 8        | P421 61202531 | 21       |
| 638-37549-1 | 24       | 649-29634-1 | 7        | 94812LDL      | 8        | P421 61222531 | 21       |
| 638-37549-2 | 24       | 649-29635-1 | 6        | 94822         | 9        | P421 91202531 | 21       |
| 644-40821-6 | 9        | 649-29636-1 | 6        | 94822LDL      | 9        | P421 91402531 | 21       |
| 644-40822-8 | 9        | 649-29637-1 | 6        | 94823         | 10       | V325120000    | 24       |
| 644-40824-1 | 13       | 649-29638-1 | 6        | 94823-12      | 10       |               |          |
| 644-40824-2 | 13       | 649-29639-1 | 7        | 94823-AC      | 10       |               |          |
| 644-40826-1 | 13       | 649-29640-1 | 7        | 94823LDL      | 10       |               |          |
| 644-40827-1 | 13       | 649-29641-1 | 7        | 94824         | 8        |               |          |
| 644-40843-8 | 9        | 649-29642-1 | 7        | 94824LDL      | 8        |               |          |
| 644-40867-1 | 13       | 650-40765-4 | 20       | 94834LDL      | 13       |               |          |
| 644-40868-1 | 13       | 650-40768-3 | 20       | 94923         | 10       |               |          |
| 644-40869-1 | 13       | 650-40768-4 | 20       | P301 31211154 | 18       |               |          |
| 644-40870-1 | 13       | 650-40768-5 | 20       | P301 31411110 | 20       |               |          |
| 644-40873-1 | 9        | 650-40915-8 | 16       | P301 31411154 | 18       |               |          |
| 644-40987-2 | 9        | 650-40915-9 | 16       | P301 42611114 | 18       |               |          |
| 644-41040-1 | 13       | 655-28716-1 | 24       | P301 42811114 | 18       |               |          |
| 644-46073-5 | 11       | 664-34005-5 | 23       | P301 61211154 | 18       |               |          |
| 644-46073-6 | 11       | 664-34005-6 | 23       | P301 61411154 | 18       |               |          |
| 644-46173-4 | 11       | 664-34195-9 | 24       | P301 62611114 | 18       |               |          |
| 644-46173-5 | 11       | 664-36070-5 | 23       | P301 62811114 | 18       |               |          |
| 644-46173-6 | 11       | 664-36070-6 | 23       | P301 91211154 | 18       |               |          |
| 644-46173-7 | 11       | 66649       | 30       | P301 91411154 | 18       |               |          |
| 644-46173-8 | 11       | 68462       | 26       | P301 92611114 | 18       |               |          |
| 644-46174-2 | 11       | 700506      | 29       | P301 92811114 | 18       |               |          |

# A complete line of lubrication solutions and industrial pumping products

## Automatic lubrication

Our automatic systems dispense measured amounts of lubricant at predetermined intervals. Systems include Helios and Duo-Matic™ two-line systems, and Centro-Matic, Modular Lube, Quicklub and ORSCO precision oil lubrication. With our BearingSaver program, we find the best automatic solution for you from our wide range of systems for grease, fluid grease and oil.



## General lubrication

Sometimes a simple approach is the best solution. Our wide range of products includes smaller, self-contained automatic lubricators and general lubrication equipment.



## Industrial pumping

Lincoln has developed specialized pumps and pumping stations to handle the difficult job of transferring thick fluids. From the industry-best PileDriver III and PowerMaster III pumps and air motors to specialty pumps, controls and mounting accessories, Lincoln is the preferred pumping system for many tough applications.





© SKF is a registered trademark of the SKF Group.

© Lincoln, Quicklub, Quickline, BearingSaver, Helios, Centro-Matic, Modular Lube, PileDriver III and PowerMaster III are registered trademarks of Lincoln Industrial Corp.

© SKF Group 2014

The contents of this publication are the copyright of the publisher and may not be reproduced (even extracts) unless prior written permission is granted. Every care has been taken to ensure the accuracy of the information contained in this publication but no liability can be accepted for any loss or damage whether direct, indirect or consequential arising out of the use of the information contained herein.

December 2014 · FORM 442833



[skf.com](http://skf.com)

Buy: [www.ValinOnline.com](http://www.ValinOnline.com) | Phone: 844-385-3099 | Email: [CustomerService@valin.com](mailto:CustomerService@valin.com)