

INSTRUCTION MANUAL

ELECTRIC LEVEL CONTROLS

LINC L471 • L471SC • LV471 • L971
SERIES

*Recognized as a
world-class leader in
Electric & Pneumatic
level control switches,
flow indicators,
chemical metering
pumps, and
allied products.*



INSTRUCTION MANUAL

O R D E R I N G I N F O R M A T I O N

To Order, Call 800.455.LINC

Or FAX your order anytime to
215.293.0498

**For the Nearest Authorized
Representative:**

By Telephone: **800.455.LINC** for
the US & Canada, **215.293.0465**
or **215.441.0800** for International
customers

By Fax: 215.293.0498

E-mail:

info@miltonroy.com

Technical Support

By Telephone: **800.455.LINC**

By e-mail:

info@miltonroy.com

INSTRUCTION MANUAL

T A B L E O F C O N T E N T S

Contents –L471, 471SC, LV471, L971 Electric Level Controls	Page
L471 & L471SC Series Ordering Chart	3-4
Scope Of This Manual	5
Product Description	5
Operation	5
Features	5
Installation	6
Maintenance	7
Float and Arm	7
Relay	7
Switch	7
Electric Relays: Installation and Maintenance	13
 Assembly Drawings & Parts Lists	
Figure 1, L471-01, 21 Level Switch	8
L471-01, 21 Level Switch Parts List	8
Figure 2, L471-02, 03 Level Switch	9
L471-02, 03 Level Switch Parts List	9
Figure 3, L471-01-04 Level Switch	10
L471-01-04 Level Switch Parts List	10
Figure 4, L471-39, 79 Level Switch	11
L471-39, 79 Level Switch Parts List	11
Figure 5, L471-69, 89 Level Switch	12
L471-69, 89 Level Switch Parts List	12
Figure 6, Electric Relay 21593	14
Electric Relay 21593 Parts List	14
Figure 7, L471SC-01, 02 Level Switch	15
L471SC-01, 02 Level Switch Parts List	15
Figure 8, L471SC-03, 04 Level Switch	16
L471SC-03, 04 Level Switch Parts List	16
LV471 & L971 Series Ordering Chart	17
Figure 9, LV471-04, LV471-04-04 Level Switch	18
LV471-04, LV471-04-04 Level Switch Parts List	19
Figure 10, L971-01, L971-01-04 Level Switch	20
L971-01, L971-01-04 Level Switch Parts List	21

LEVEL CONTROL SWITCHES

LINC - L471 & L471SC SERIES

The LINC-L471 & L471SC Series: Electric Level Control Switches

Application:

Used as a high & low level control, the L471 & L471SC can activate alarms, provide a switch input for control systems, or perform a variety of desired electrical switch operations actuated by a liquid or liquid interface.

Operation:

As the float is moved by varying liquid height, a magnet is moved closer to or further away from a switch enclosure. As the magnet moves closer, a reed switch in the enclosure closes. As the magnet moves further away, the switch opens. The arm containing the magnet also acts as a counterweight for the float.

The float is small and will operate in liquids with a specific gravity as low as 0.4. The interface type will operate with a specific gravity differential as low as 0.1. This small float permits an economical installation in locations where other controls would be cost prohibitive. Available with a relay mounted in an explosion-proof case allowing the control of larger electrical loads. The manual override option allows the operator to manually move the float arm to the test switch position.

Benefits:

- Easy to Repair.....
- Easy to Field Test.....
- No Leaks.....
- Lower Operating Costs.....
- Lower Inventory.....
- Versatile.....
- Safe.....
- Corrosion Resistant.....
- Reliable.....
- High & Low Pressure Applications.....

Features:

- Repairs on-site in 20 minutes with the Quick-Change switch cartridge
- The Manual Override option enables mechanical and electrical function testing while installed
- Environmentally-isolated design keeps operational fluids away from electrical circuitry
- Quick-Change, inexpensive replacement parts
- One L471 inverts for both High & Low level applications
- One L471 provides both normally open, and normally closed switching by simply inverting the L471
- Certified as explosion-proof¹ for Hazardous Locations: Class I, Div. 1, Groups A, B, C, D; Class II, Div. 1, Groups E, F, G; and Class III, Div. 1, by CSA a Nationally recognized Testing Laboratory in the U.S. and Canada
- Standard 316 Stainless Steel wetted and housing components for corrosion resistance
- Sealed switch cartridge prevents dust, fluids, and corrosion from interfering with electrical circuitry
- Available with Stainless Steel and Polypropylene displacer options for various process pressures

¹ When a relay assembly is used, Class I, Div. 1, is limited to Groups C and D.

LEVEL CONTROL SWITCHES

LINC - L471 & L471SC SERIES

Specifications: L471 & L471SC Series Electric Level Control Switches

Pressure: <input type="checkbox"/>	1,500 psi standard, available to 5,000 psi, (1,500 psi maximum with the Manual Override option) <input type="checkbox"/>
Temperature:	-40°F to + 400°F standard. <input type="checkbox"/>
Specific Gravity: <input type="checkbox"/>	0.4 minimum standard; interface 0.1 differential minimum <input type="checkbox"/>
Materials: <input type="checkbox"/>	316 stainless steel wetted parts are standard.
Switch Rating: <input type="checkbox"/>	SPST (SPDT optional) 100 V.A. AC, 100W DC, 3 amp inrush capability, maximum of 250 Volts, Hermetically sealed <input type="checkbox"/>
Connections:	
Electrical: <input type="checkbox"/>	1/2" conduit standard, with other sizes optional
Process: <input type="checkbox"/>	1 1/2" NPT standard, available in 2" NPT, 3" flanged or larger, and externally caged <input type="checkbox"/>
CSA Certification: <input type="checkbox"/>	Listed as explosion-proof for Class I, Div. 1, Groups A, B, C, D; Class II, Div. 1, Groups E, F, G; and Class III, Div. 1 <input type="checkbox"/>

Ordering Chart:

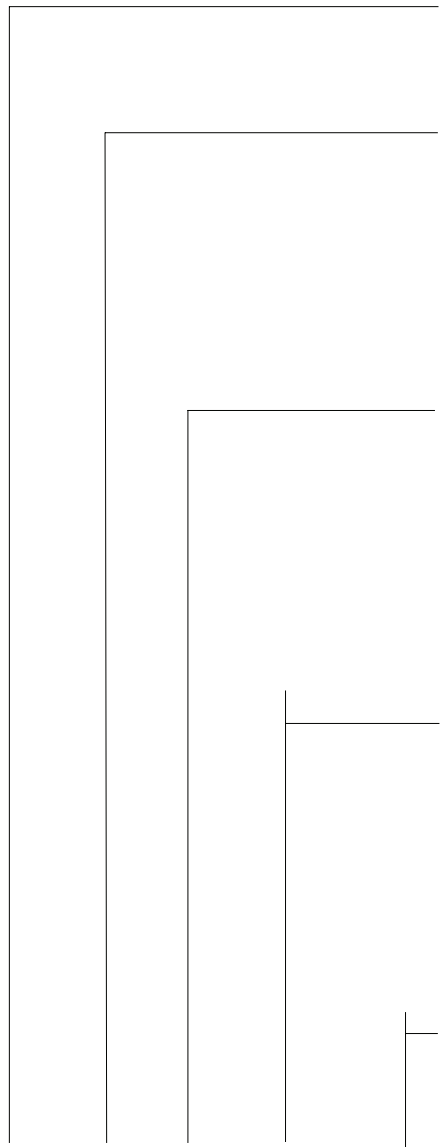

- Series:**
- L471 - Electric level control
 - L471SC - Externally caged electric level control. Note: The body style is always "0" due to ring bolt. 1,500 psi WP standard; 3,000 psi WP available ²
- Body Style:**
- 0 - Standard, 1 1/2" NPT (ring bolt on L471SC)
 - 1 - Standard, 2" NPT
 - 2 - Standard, 1 1/2" NPT, manual override ³
 - 4 - Standard, 2" NPT, manual override ³
 - 3 - Extd. body ⁴, 2" NPT, vertical displacer
 - 6 - Extd. body ⁴, 2" NPT, vertical displacer, manual override
 - 7 - Extd. body ⁴, 2" NPT, horizontal displacer
 - 8 - Extd. body ⁴, 2" NPT, horizontal displacer, manual override
- Type:**
- 1 - Standard
 - 2 - High pressure, 5,000 psi polypropylene displacer, temp. +180°F max, spec. grav. 0.6 min. CSA rated to 1500 psi per single seal rating (consult factory for higher ratings)
 - 3 - Interface, 5,000 psi polypropylene displacer, temp. +180°F max, upper fluid less than: .870 spec. grav; lower fluid more than: .970 spec. grav.
 - 4 - Other gravities for interface, specify gravities of fluids (upper & lower)
 - 9 - Displacer, 5,000 psi polypropylene displacer, temp. +180°F max, spec. grav. 0.5 min.
- Other ⁵:**
- 02 - Annulus plug
 - 03-N - Relay assembly ¹, general purpose plug- in, 24VDC DPDT 10 Amp
 - 04-N - Relay assembly ¹, general purpose plug- in, 120VAC DPDT 10 Amp
 - 08-N - Relay assembly ¹, hermetically sealed plug- in, 24VDC DPDT 10 Amp
 - 09-N - Relay assembly ¹, hermetically sealed plug- in, 120VAC DPDT 10 Amp
 - 05 - This number means special; specify your requirements. i.e. 3" flanged 150# RF
- Option Number:**
- () - Factory will assign an option number based on specified requirements.
- ¹ When a relay assembly is used, Class I, Div. 1, is limited to Groups C, and D.
² L471SC pressure limitation is 3,000 psi on cage.
³ Not available on L471SC. 1500 psi maximum. Manual override.
⁴ Body style 3, 6, 7, 8 available only Type 9.
⁵ If no further requirements are desired, omit "Other" option codes from the part number.

LINC- - - ()

Example: LINC-L471-21-05 electric level control

INSTRUCTION MANUAL

PRODUCT DESCRIPTION

Scope Of This Manual:

This manual describes and provides instructions and parts lists for the LINC-L471, LINC-L471SC, LINC-LV471 and LINC-L971 Series Electric Level Controls.

Product Description:

Used as a high & low level control, the L471 & L471SC can activate alarms, provide a switch input for control systems, or perform a variety of desired electrical switch operations actuated by a liquid or liquid interface.

Operation:

As the float is moved by varying liquid height, a magnet is moved closer to or further away from a switch enclosure. As the magnet moves closer, a reed switch in the enclosure closes. As the magnet moves further away, the switch opens. The arm containing the magnet also acts as a counterweight for the float.

The float is small and will operate in liquids with a specific gravity as low as 0.4. The interface type float will operate with a specific gravity differential as low as 0.1. The small float permits an economical installation in locations where other controls would be cost prohibitive. With the optional relay mounted in an explosion-proof case, the control of larger electrical loads can be obtained. The manual override option allows the operator to manually move the float arm to the test switch position. The SC Series is designed to eliminate the threaded control connection in mounting with the use of a bolted ring per API recommended practice FIND. The external cage allows for installation of the control at any elevation.

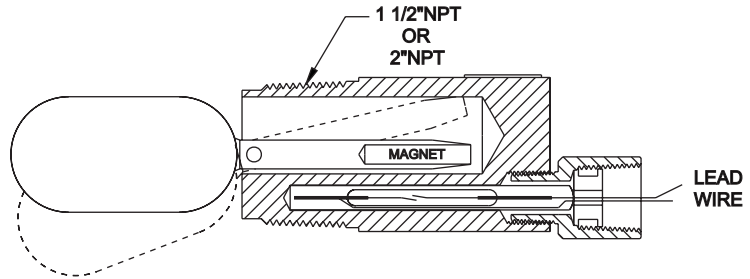

Drawing 1

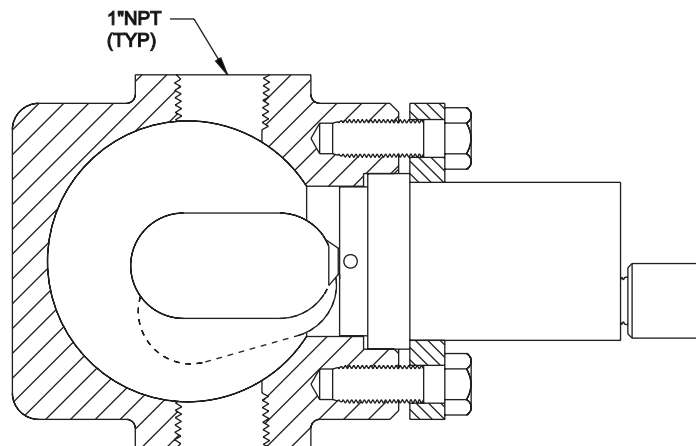

Drawing 2

Features:

- All wetted parts isolated from the environment. These level controls are safe even in the event of fire.
- *Certified as explosion proof for Hazardous Locations: Class I, Div. 1, Groups A, B, C, D; Class II, Div. 1, Groups E, F, G; & Class III, Div. 1.
- All 316 stainless steel wetted parts provide corrosion resistance.
- Our sealed switch assembly prevents dust, dirt, or moisture from affecting the level control's operation. Classified "Factory Sealed" by CSA/NRTL/C.
- Cartridge switch assembly provides easy field replacement and servicing.
- High or low alarm, normally open or normally closed operation simply by inverting the level control.

*When a relay assembly is used, Class I, Div. 1, is limited to groups C and D.

INSTRUCTION MANUAL

I N S T A L L A T I O N

Installation:

Before installing the level control, inspect the unit for any damage. The float arm must pivot freely. Thread the level control into the desired connection. See Drawing 3 for Suggested installations. The float requires a minimum clearance of 1 1/4" from the center line of the unit for proper operation. For fail-safe operation as a high level alarm, the conduit connection must be positioned to the highest possible location. For operation as a low level alarm, the conduit connection must be positioned to the lowest possible location. Wiring connections may now be made. Do not allow the wiring connections to pull on the switch assembly.

Caution: Do not exceed switch ratings.

LINC-L471, LINC-L471SC:
SPST, 100 VA AC with 3 AMP
inrush capability, maximum 250
volts.

Breakdown voltage is 300 volts. Electrical ratings are given for resistive loads. For inductive loads, de-rate the switch rating by 50% and do not exceed the VA ratings on the inrush current. If the applied load is inductive, such as a relay or coil, then a protective device should be used to prevent "inductive kick," which may burn the switch contacts. The protective device recommended is dependent on the voltage used. For DC operation, a diode similar to an 1N34A should be wired in parallel with the switch. See Page 11 wiring schematic. For AC operation, a Varistor should be wired in parallel with the switch.

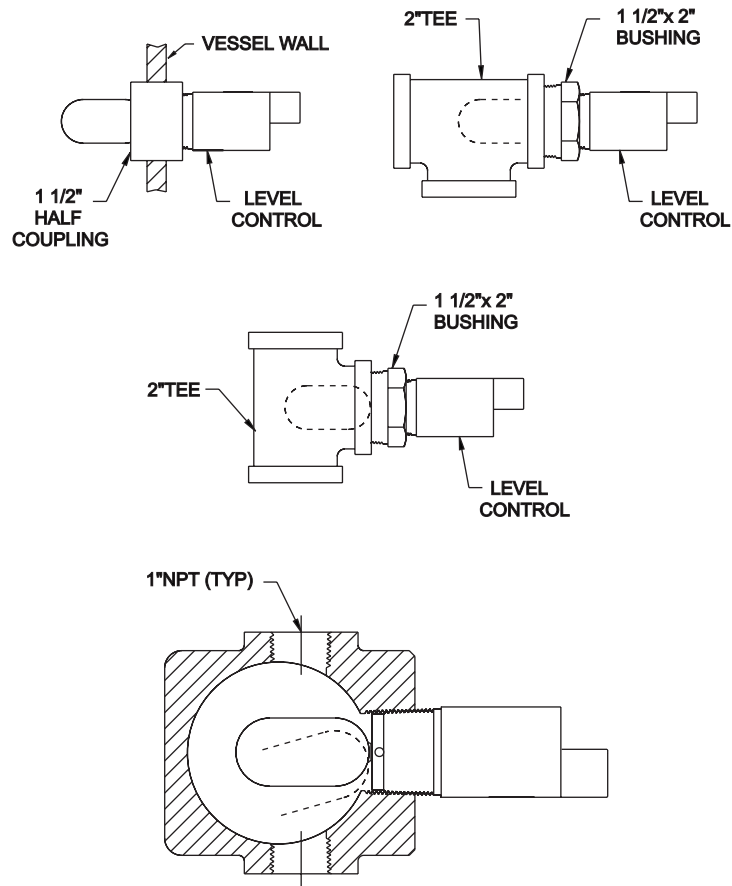

Drawing 3

For SPST Switch Cartridge

Wiring:

White - Common

Black - Normally Open

For SPDT Switch Cartridge

Wiring:

White - Common

Black - Normally Closed

Red - Normally Open

INSTRUCTION MANUAL

M A I N T E N A N C E

Maintenance:

The LINC-L471 and LINC-L471SC Series electric level controls have been designed to be as maintenance free as possible. However, the component parts are subject to normal wear and must be inspected and replaced as necessary.

Inspection and maintenance frequency depend upon the severity of service conditions.

Instructions are provided in this section for maintaining the controls as units, i.e., float and float arm, relay and switch cartridge.

All the maintenance procedures below assume that the control has been removed from service. The switch and relay can be serviced with the control installed. The power must be disconnected before removing the relay enclosure cover or opening the conduit fitting.

Float and Arm

Check the physical clearance for float operation. The float must swing freely. Solvent cleaning of the float arm chamber may be required if used in viscous or dirty liquids. If the float has collapsed or is perforated, unscrew the float from the float arm and replace with a new float. Use Loctite[®] to secure the float to the float arm. To remove the float arm, drive out the pivot pin using a 1/8" punch. When installing the float arm, make certain that the threaded offset of the float arm is against the thick wall of the body.

Relay:

To test for proper relay function, disconnect the switch leads from the relay socket. Apply appropriate voltage to the coil terminals and observe the relay contact closure with an ohmmeter

connected across the common and normally closed contacts. Interrupt the coil power supply several times while observing the ohmmeter. No movement indicates a defective relay, coil or contacts. This procedure should be repeated for each set of contacts in service.

To remove a defective relay, simply pull the relay from the socket and replace with a new relay.

When ordering a replacement relay, be certain to specify coil voltage. After installing a new relay, reconnect the switch leads.

Switch:

To test for switch malfunction, connect an ohmmeter across the electrical leads and observe the meter as the float assembly is mechanically operated. No meter movement indicates a switch failure.

To replace a switch on the LINC-L471 or LINC-L471SC Series, pull out the switch cartridge along with the grommet through the conduit adapter. Slide the new switch cartridge into the body. Route the switch wired through the grommet and seat the grommet in the conduit adapter.

INSTRUCTION MANUAL

L I N C - L 4 7 1 - 0 1

Figure 1, LINC L471-01 Level Switch

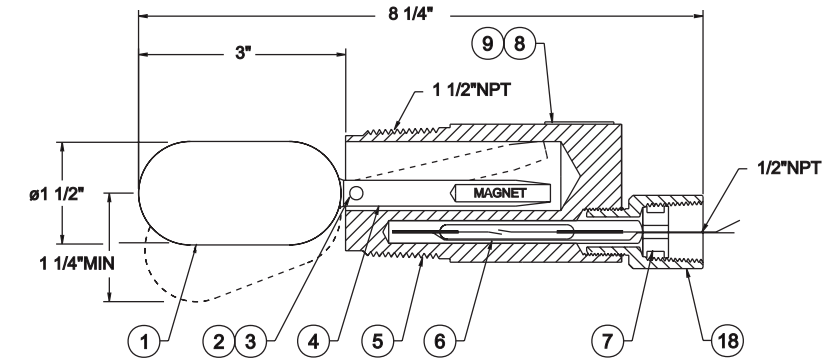

Model LINC-L471-01

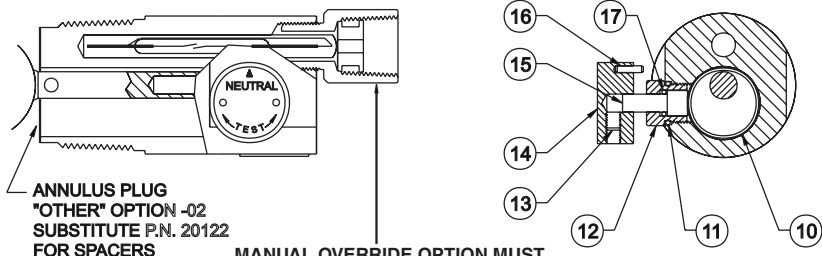

ANNULUS PLUG
"OTHER" OPTION -02
SUBSTITUTE P.N. 20122
FOR SPACERS

MANUAL OVERRIDE OPTION MUST
BE INSTALLED WITH CONDUIT
CONNECTION IN 12:00 O'CLOCK POSITION.

MANUAL OVERRIDE, STANDARD BODY
Body Styl -

The LINC 471-01 & 471-21 Series Parts List.

Model	L471-01	L471-21	Description	Material	Qty
1	10245	10245	Float	316 ss	1
2	20120	20120	Pin	316 ss	1
3	20121	20121	Spacer	316 ss	2
4	20853	24883	Float Arm Assembly	316 ss	1
5	30313	30715	Body	316 ss	1
6*	20495	20495	Switch Cartridge	304 ss	1
7	10087	10087	Grommet	Nitrile	1
8	10012	10012	Name Plate	316 ss	1
9	10324	10324	Drive Screw (not shown)	18-8 ss	4
10		24885	Ring Weldment	316 ss	1
11		10996	O-Ring	Fluorocarbon	1
12		22271	Packing Gland	316 ss	1
13	AIC3214SS		Set Screw	18-8 ss	1
14		22577	Knob	303 ss	1
15		24875	Stem	316 ss	1
16		11192	Roll Pin	18-8 ss	3
17		10108	O-Ring	Fluorocarbon	1
18	20119	20119	Conduit Adapter	316 ss	1
	24836	24836	Switch Cartridge SPDT 400° F (Optional)	Sealed	1

*Recommended spare

INSTRUCTION MANUAL

LINC - L471 - 02 & LINC - L471 - 03

Figure 2, LINC L471-02 & 03 Level Switch

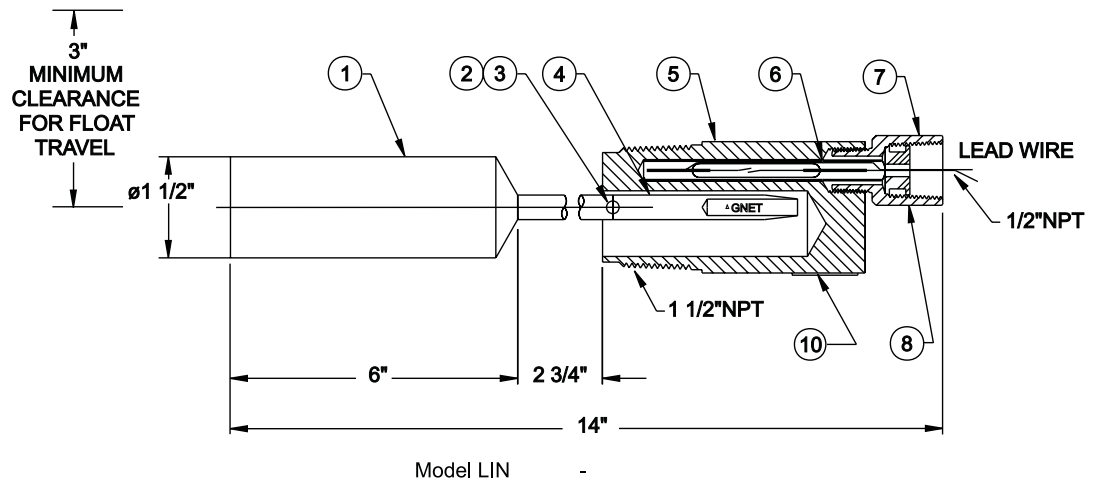
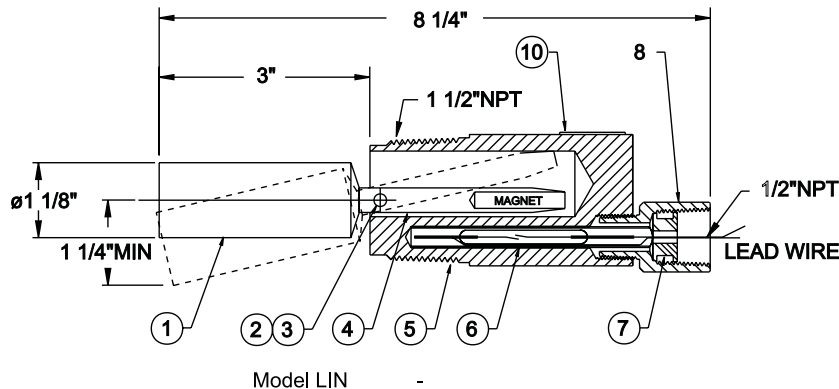

The LINC 471-02 & 471-03 Series Parts List.

Model	L471-02	L471-03	Description	Material	Qty
1	20149	20136	Float	Polypropylene	1
2	20120	20120	Pin	316 ss	1
3	20121	20121	Spacer	316 ss	2
4	20853	21671	Float Arm Assembly	316 ss	1
5	30313	30313	Body	316 ss	1
6*	20495	20495	Switch Cartridge	Sealed	1
7	10087	10087	Grommet	Nitrile	1
8	20119	20119	Conduit Adapter	316 ss	1
10	10324	10324	Drive Screw (not shown)	18-8 ss	2
	24836	24836	Switch Cartridge SPDT 400° F (Optional)	Sealed	1

*Recommended spare

INSTRUCTION MANUAL

L I N C - L 4 7 1 - 0 1 - 0 4

Figure 3, LINC L471-01-04-N Level Switch

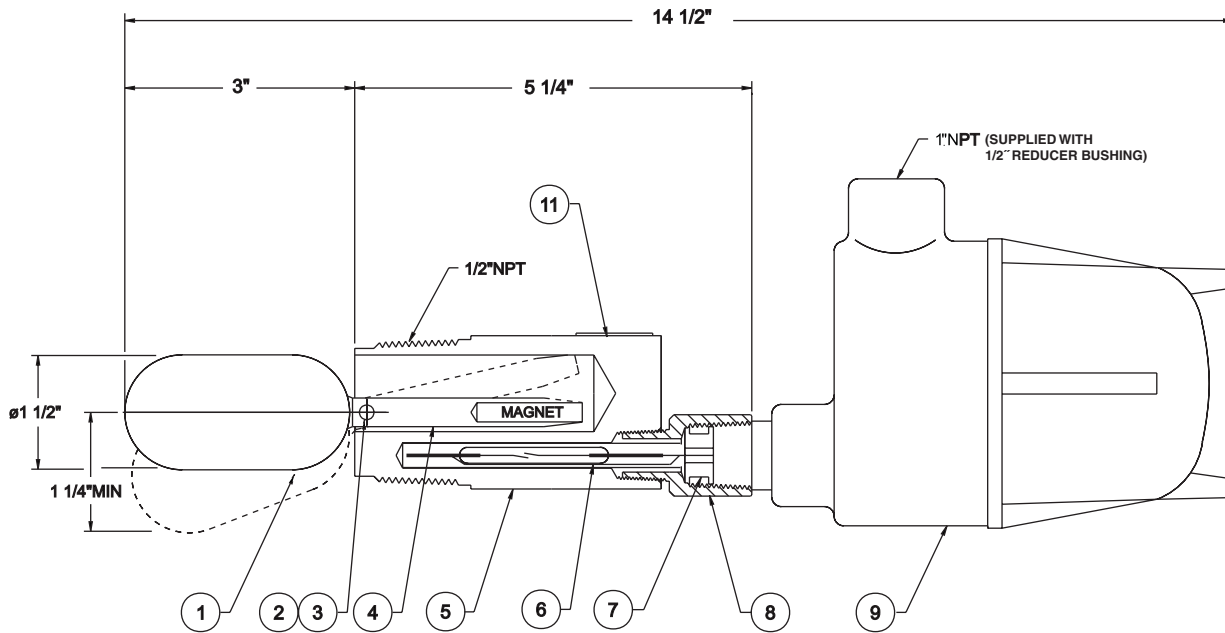

Model LINC L471-01-04-N

The LINC 471-01-04-N Series Parts List.

Model	L471-01-04-N			
Item	Part #	Description	Material	Qty
1	10245	Float	316 ss	1
2	20120	Pin	316 ss	1
3	20121	Spacer	316 ss	2
4	20853	Float Arm Assembly	316 ss	1
5	30313	Body	316 ss	1
6*	20495	Switch Cartridge	Sealed	1
7	10087	Grommet	Nitrile	1
8	20119	Conduit Adapter	316 ss	1
9	21593	Relay Assembly (110 VAC see relays)		1
11	10324	Drive Screw (not shown)	18-8 ss	2

*Recommended spare

INSTRUCTION MANUAL

L I N C - L 4 7 1 - 3 9 & 7 9

Figure 4, LINC L471-39 & 79 Level Switch

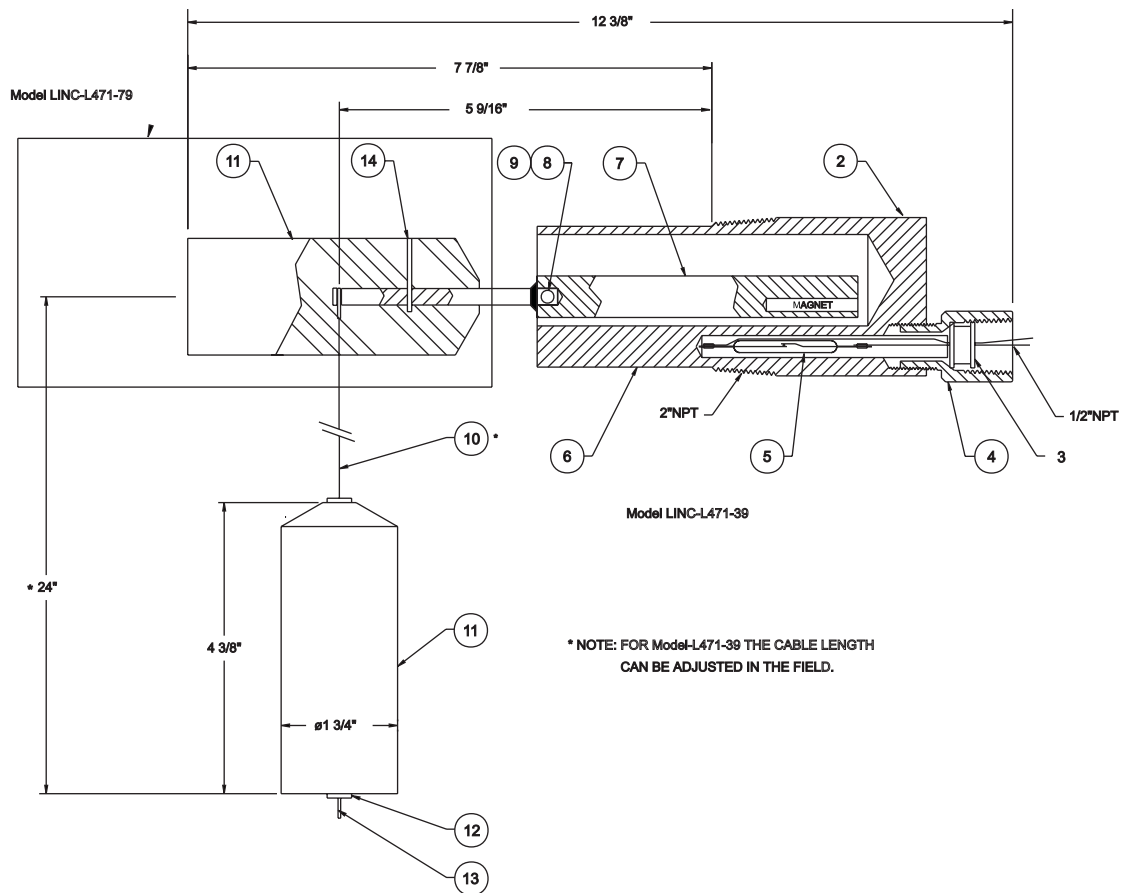

The LINC 471-39 & 79 Series Parts List.

Model	L471-39	L471-79	Description	Material	Qty
2	10324	10324	Drive Screw	18-8 ss	2
3	10087	10087	Grommet	Nitrile	1
4	20119	20119	Conduit Adapter	316 ss	1
5**	20495	20495	Switch Cartridge	Sealed	1
6	31079	31079	Body	316 ss	1
7	23540	23540	Float/Magnet Arm	316 ss	1
8	20334	20334	Pin	316 ss	1
9	23604	23604	Spacer	316 ss	2
10	11566		Wire Cable	304 ss	24"
11	23503	23503	Displacer	Polypropylene	1
12	23500		Stop Ring	316 ss	1
13	11565		Crimp	18-8 ss	3
14		11571	Pin	316 ss	1
	24836	24836	Switch Cartridge SPDT 400° F (Optional)	Sealed	1

**Recommended spare

INSTRUCTION MANUAL

L I N C - L 4 7 1 - 6 9 & 8 9

Figure 5, LINC L471-69 & 89 Level Switch

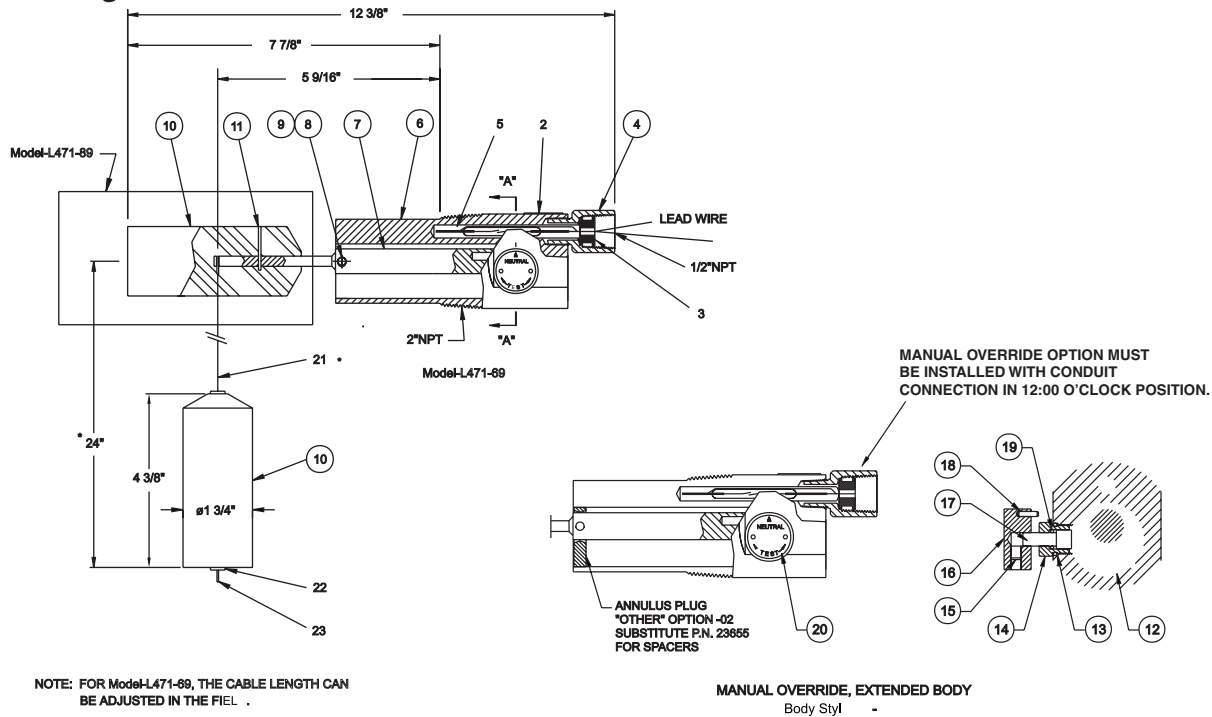

The LINC 471-69 & 89 Series Parts List.

Model	L471-69	L471-89	Description	Material	Qty
2	10324	10324	Drive Screw	18-8 ss	4
3	10087	10087	Grommet	Nitrile	1
4	20119	20119	Conduit Adapter	316 ss	1
5*	20495	20495	Switch Cartridge	Sealed	1
6	31079	31265	Body	316 ss	1
7	24083	24083	Float/Magnet Arm	316 ss	1
8	20334	20334	Pin	316 ss	1
9	23604	23604	Spacer	316 ss	1
10	23503	23503	Displacer	Polypropylene	1
11		11571	Pin	316 ss	1
12	24887	24887	Ring Weldment	316 ss	1
13	10996	10996	O-Ring	Fluorocarbon	1
14	22271	22271	Packing Gland	316 ss	1
15	AIO 3214 ss		Set Screw	18-8 ss	1
16	22577	22577	Knob	303 ss	1
17	24875	24875	Stem	316 ss	1
18	11192	11192	Roll Pin	18-8 ss	3
19	10108	10108	O-Ring	Fluorocarbon	1
20	11193	11193	Name Plate Manual Check	304 ss	1
21	11566		Wire Cable	304 ss	
22	23500		Stop Ring	316 ss	2
23	11565		Crimp	18-8 ss	3
	24836	24836	Switch Cartridge SPDT 400° F (Optional)	Sealed	3

*Recommended spare

INSTRUCTION MANUAL

ELECTRIC RELAYS

Electric Relays

Installation & Maintenance:

• AC Voltage DPDT Plug-In Type Relay Or DC Voltage DPDT Plug-In Type Relay:

1. Check the relay coil to assure it is rated for your source voltage.
2. Connect one side of the source to the white wire within the enclosure using accepted electrical practices. Connect the other side of the source (black wire) terminal #2.
3. The load may now be wired to terminals #1, #3, #4 and #8, #5 and #6.
4. Secure the enclosure cover prior to applying source voltage.
5. Apply source voltage.

For use in an SPDT function, follow the above instructions, except omit connections for the load to terminals #8, #5, and #6.

Caution:

On DC applications, the protective device is directional. If polarity is reversed, the switch could be damaged.

WIRING SCHEMATIC

FOR AC VOLTAGE DPDT, PLUG-IN TYPE RELAY

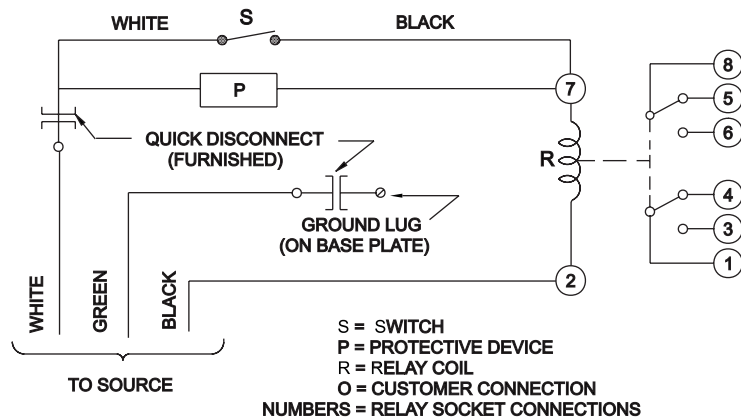

WIRING SCHEMATIC

FOR DC VOLTAGE DPDT, PLUG-IN TYPE RELAY

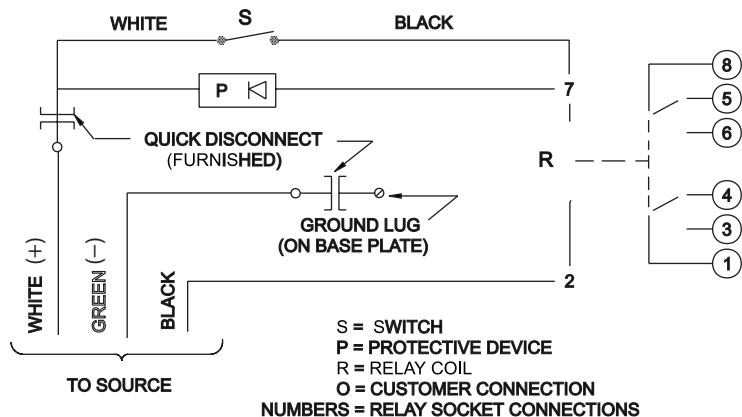

INSTRUCTION MANUAL

ELECTRIC RELAYS

Figure 6, Electric Relay: LINC 21593

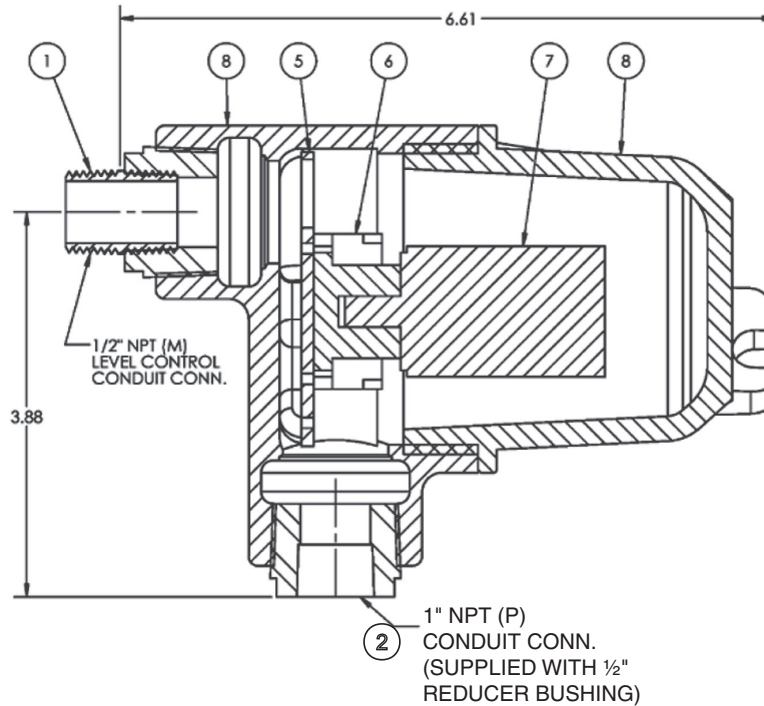

L21593

Model	LINC-21593 115 VAC Plug-In Relay			
Item	Part #	Description	Material	Qty
1	10236	Nipple	Galvanized	1
2	L25757 Reducer	Bushing	Brass	1
3	10189	Round Head Screw	Plated	1
4	12001	Terminal ring	Insulated	1
5	20948	Mounting Plate	Aluminum	1
6	10472	Relay Base	Plastic	1
7*	10688	Relay (110 VAC)		1
8**	25747	Relay Enclosure with Lid	Plated	1

*Recommended spare
 **Dome Cover supplied when Relay is ordered

INSTRUCTION MANUAL

LINC-L471SC-01 & LINC-L471SC-02

Figure 7, LINC L471SC-01 & 471SC-02 Level Switch

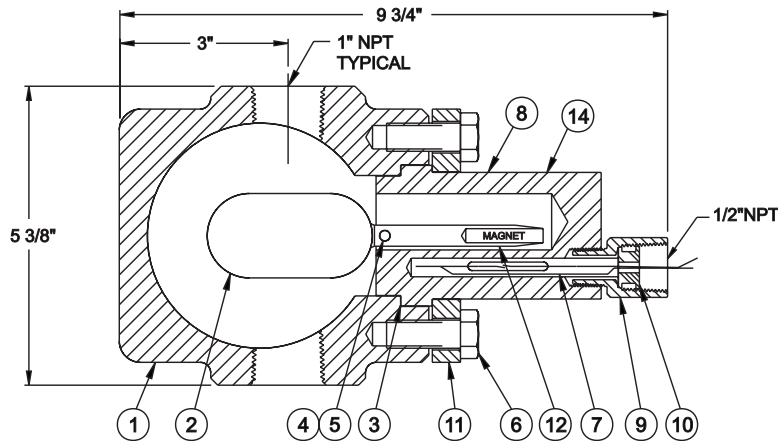

Model LINC-L471SC-01

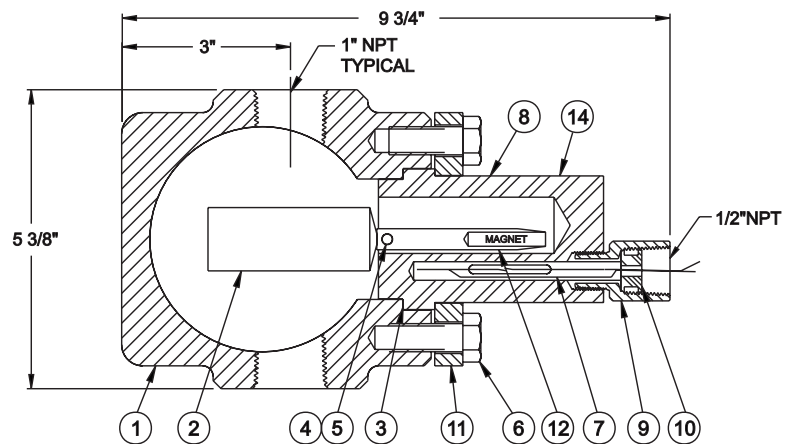

Model LINC-L471SC-02

The LINC 471SC-01, 471SC-02 Series Parts List.

Model	L471SC-01	L471SC-02	Description	Material	Qty
1	40256	40256	Cage	Cast Steel	1
2	10245		Float	316 ss	2
		20149	Float	Polypropylene	1
3*	11257	11257	Gasket	TFE	1
4	20334	20334	Pin	316 ss	1
5	20121	20121	Spacer	316 ss	2
6	10211	10211	Cap Screw	Plated	6
7*	20495	20495	Switch Cartridge	Sealed	1
8	30282	30282	Body	316 ss	1
9	20119	20119	Conduit Adapter	316 ss	1
10	10087	10087	Grommet	Nitrile	1
11	30258	30258	Ring Flange	Steel	1
12	20853	20853	Float Arm Assembly	316 ss	1
14	10324	10324	Drive Screw (not shown)	18-8 ss	2
	24836	24836	Switch Cartridge SPDT 400° F (Optional)	Sealed	1

*Recommended spare

INSTRUCTION MANUAL

LINC - L471SC-03 & LINC - L471SC-04

Figure 8, LINC L471SC-03 & 04 Level Switch

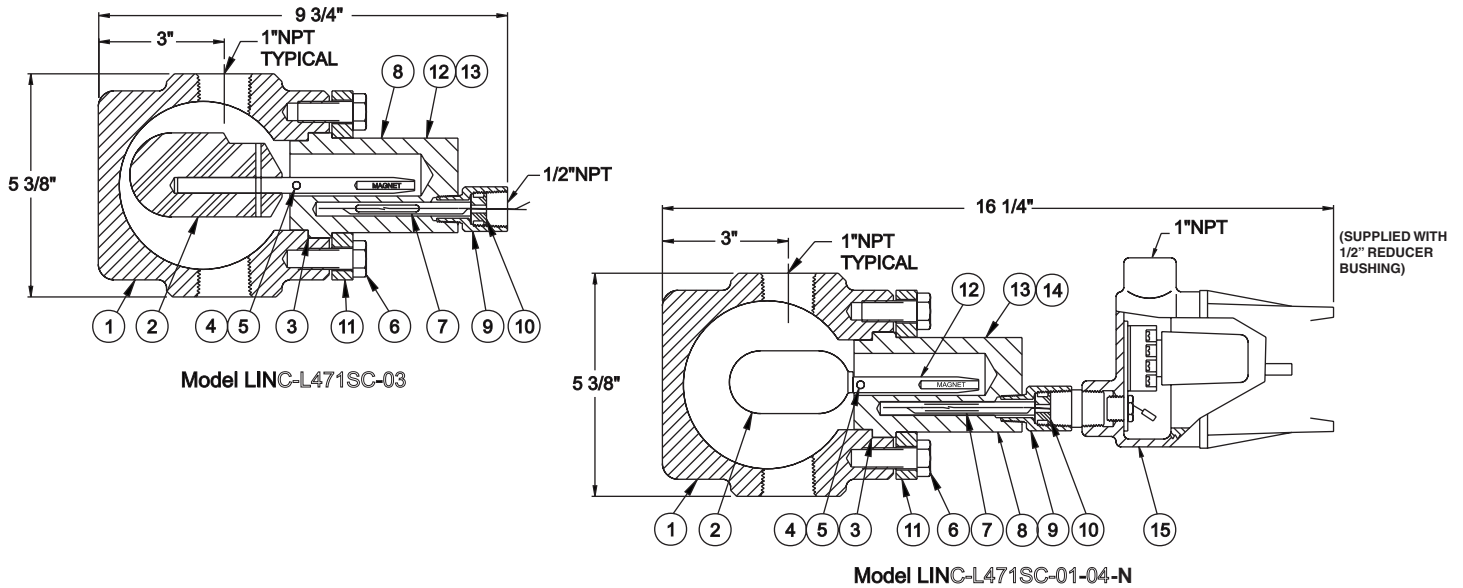

The LINC 471SC-03 & 04 Series Parts List.

Model	L471SC-03	L471SC-04	Description	Material	Qty
1	40256	40256	Cage	Cast Steel	1
2	10245	10245	Float	316 ss	1
3*	11257	11257	Gasket	TFE	1
4	20334	20334	Pin	316 ss	1
5	20121	20121	Spacer	316 ss	2
6	10211	10211	Cap Screw	Plated	6
7*	20495	20495	Switch Cartridge	Sealed	1
8	30282	30282	Body	316 ss	1
9	20119	20119	Conduit Adapter	316 ss	1
10	10087	10087	Grommet	Nitrile	1
11	30258	30258	Ring Flange	Steel	2
12	10013	See below	Name Plate	316 ss	1
13	10324	See below	Drive Screw (not shown)	18-8 ss	2
	24836	See below	Switch Cartridge SPDT 400° F (Optional)	Sealed	1
*Recommended spare					
Model	L471SC-01-04-N		Description	Material	Qty
12	20853		Float Arm Assembly	316 ss	1
13	10013		Name Plate	316 ss	1
14	10324		Drive Screw (not shown)	18-8 ss	2
15	21593		Relay Assembly (110 VAC see relays)		1
*Recommended spare					

LEVEL CONTROL SWITCHES

LINC - LV471 & L971 SERIES

Specifications: LV471 Vertical Series & L971 Extended Body Series Electric Level Control Switches		
Series: <input type="checkbox"/>	LV471 Vertical <input type="checkbox"/>	L971 Horizontal Extended Body Series <input type="checkbox"/>
Pressure: <input type="checkbox"/>	250 psi <input type="checkbox"/>	2,500 psi <input type="checkbox"/>
Temperature: <input type="checkbox"/>	-40°F to + 400°F standard <input type="checkbox"/>	-40°F to + 180°F <input type="checkbox"/>
Specific Gravity: <input type="checkbox"/>	0.7 minimum <input type="checkbox"/>	0.6 minimum <input type="checkbox"/>
Materials: <input type="checkbox"/>	316 stainless steel wetted parts <input type="checkbox"/>	Displacer is polypropylene. Other wetted parts 316ss <input type="checkbox"/>
Connections:		
Process: <input type="checkbox"/>	1-1/2" NPT vertical, available flanged, specify type <input type="checkbox"/>	1" NPT std., available in 1-1/2" NPT or flanged, specify <input type="checkbox"/>
Electrical: <input type="checkbox"/>	1/2" conduit, with other sizes optional <input type="checkbox"/>	1/2" conduit, with other sizes optional <input type="checkbox"/>
Switch Rating: <input type="checkbox"/>	SPST (SPDT optional) 100 V.A. AC, 100W DC, 3 amp inrush capability, maximum of 250 Volts, Hermetically sealed <input type="checkbox"/>	
CSA Certification: <input type="checkbox"/>	Listed as explosion-proof for Class I, Div. 1, Groups A, B, C, D ² ; Class II, Div. 1, Groups E, F, G; and Class III, Div.1 <input type="checkbox"/>	

Ordering Chart:

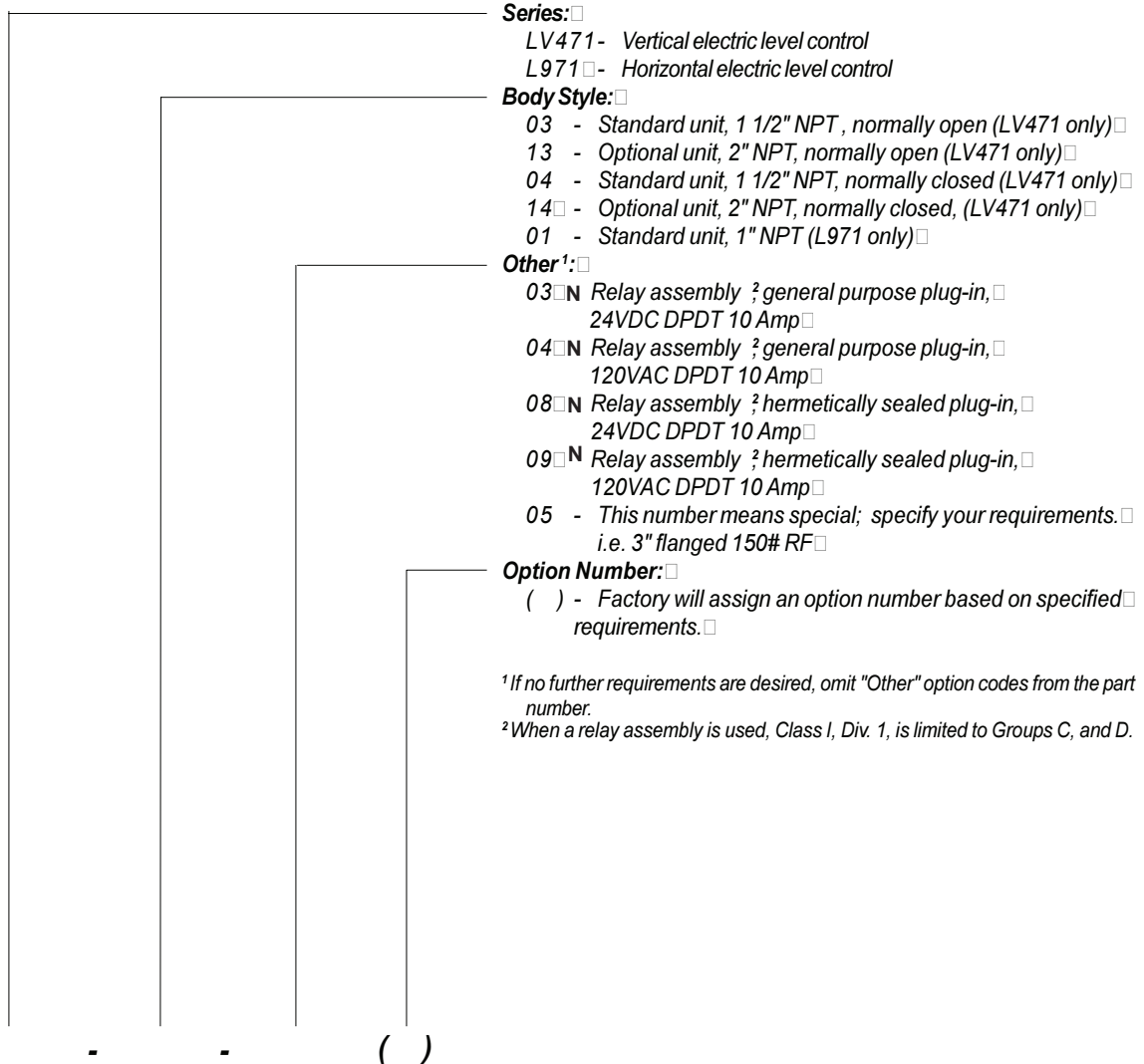

Example: LINC-LV471-04-05 electric level control

Specify: 3" - 150# RF, CS flange, 10" arm extension, 120 VAC relay

INSTRUCTION MANUAL

L I N C - L V 4 7 1 : V E R T I C A L

Figure 9, LINC LV471-04, Vertical Level Switch

Product Description:

The LV-471 is used as a high or low level control to sound alarms, operate control equipment or perform a variety of desired electrical functions. These controls will operate in any specific gravity of 0.7 or higher. The standard unit has a 3" O.D. spherical float and is rated at 250 psi. The standard float arm is 4" long. Various floats and float arm lengths are available to fit your application. These controls are available with a normally closed or normally open switch arrangement. This unit is installed through a 1-1/2" NPT fitting and the float is attached with a cotter key after the body is screwed into place. Various flanged models are also available to meet your specifications.

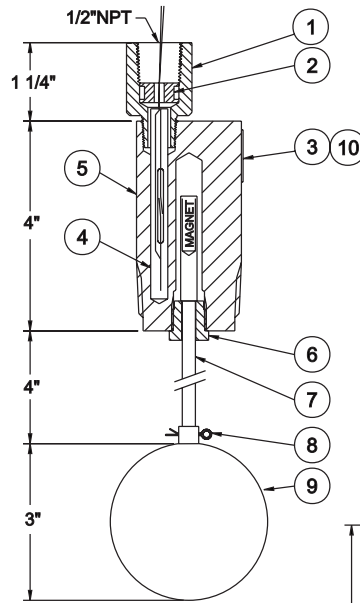

Model LINC-LV471-04
Normally Closed

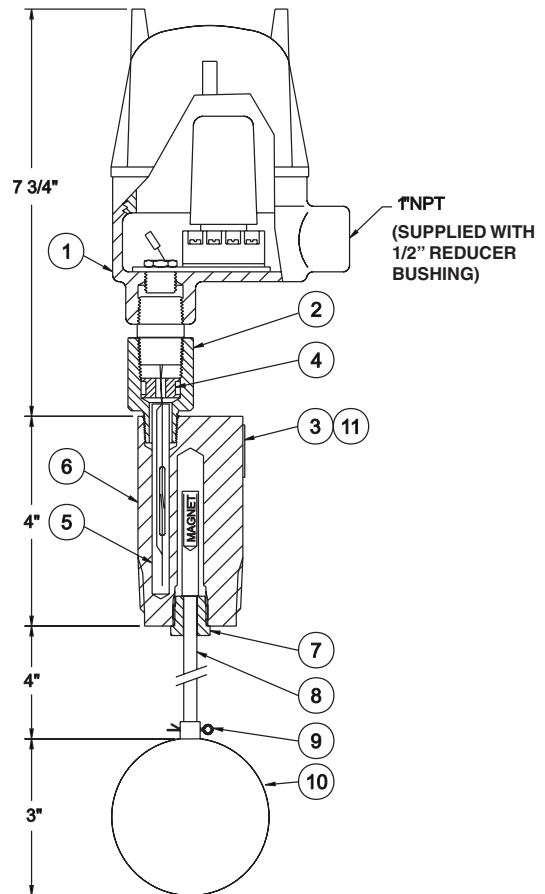

Model LINC-LV471-04-04-N
Normally Closed

INSTRUCTION MANUAL

L I N C - L V 4 7 1 : V E R T I C A L

The LINC LV471-04 Normally Closed Parts List.

Model	LV471-04 Normally Closed			
Item	Part #	Description	Material	Qty
1	20119	Conduit Adapter	316 ss	1
2	10087	Grommet	Nitrile	1
3	10012	Name Plate	316 ss	1
4*	20495	Switch Cartridge	Sealed	1
5	30316	Body	316 ss	1
6	20152	Float Arm Retainer	316 ss	1
7	20444	Float Arm Assembly	316 ss	1
8	10237	Cotter Pin	18-8 ss	1
9	10250	Float	316 ss	1
10	10324	Drive Screw (not shown)	18-8 ss	2
	24836	Switch Cartridge SPDT 400° F (Optional)	Sealed	1

*Recommended spare

Note: For models below, use the same parts as listed above with the following exceptions:

Model	LV471-03 Normally Open			
Item	Part #	Description	Material	Qty
7	20446	Float Arm Assembly	316 ss	1

The LINC LV471-04-04 Normally Closed Parts List.

Model	LV471-04-04-N Normally Closed			
Item	Part #	Description	Material	Qty
1	21593	Relay Assembly (110 VAC see relays)		1
2	20119	Conduit Adapter	316 ss	1
3	10419	Name Plate	316 ss	1
4	10087	Grommet	Nitrile	1
5*	20495	Switch Cartridge	Sealed	1
6	30316	Body	316 ss	1
7	20152	Float Arm Retainer	316 ss	1
8	20444	Float Arm Assembly	316 ss	1
9	10237	Cotter Pin	18-8 ss	1
10	10250	Float	316 ss	1
11	10324	Drive Screw (not shown)	18-8 ss	2
	24836	Switch Cartridge SPDT 400° F (Optional)	Sealed	1

*Recommended spare

Note: For models below, use the same parts as listed above with the following exceptions:

Model	LV471-03-04-N Normally Open			
Item	Part #	Description	Material	Qty
8	20446	Float Arm Assembly	316 ss	1

INSTRUCTION MANUAL

LINC-L971 SERIES: EXTENDED BODY

LINC L971 Series: Extended Body

Product Description:

The L971 is used as a high or low level control. The electrical switch closure may be used to sound alarms, operate control equipment or perform any desired electrical function.

These standard units are installed through a 1" NPT fitting. The standard float is a solid, high-density polypropylene material and will operate in specific gravities of 0.6 or higher. Due to the length of the float, these controls must have 3" of vertical clearance for the unit to operate. This control is available in a wide variety of designs to meet any specific requirements.

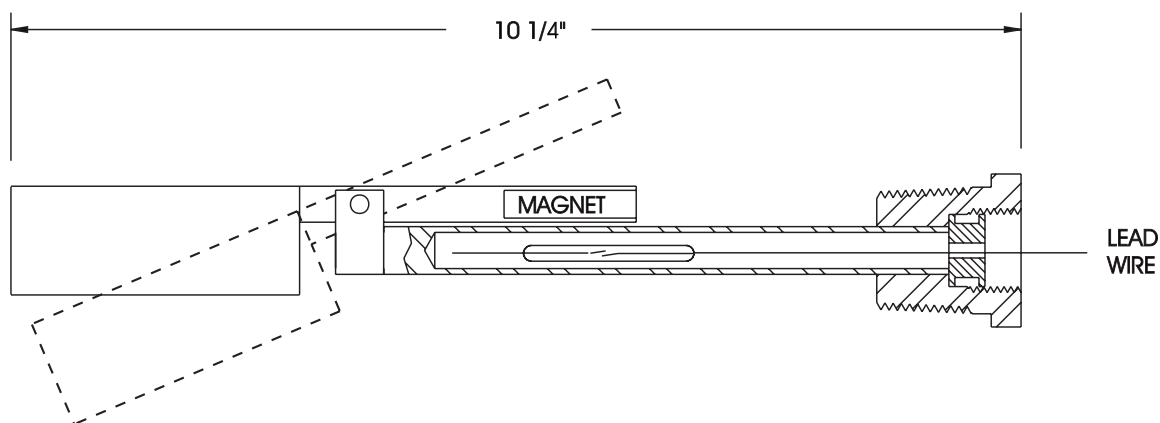

INSTRUCTION MANUAL

LINC-L971 SERIES: EXTENDED BODY

Figure 10, LINC L971-01 and L971-01-04-N Series: Extended Body

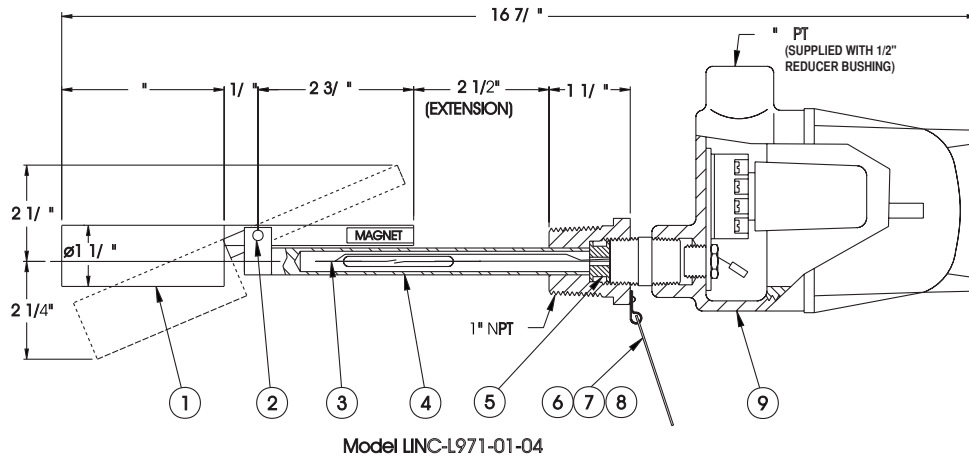
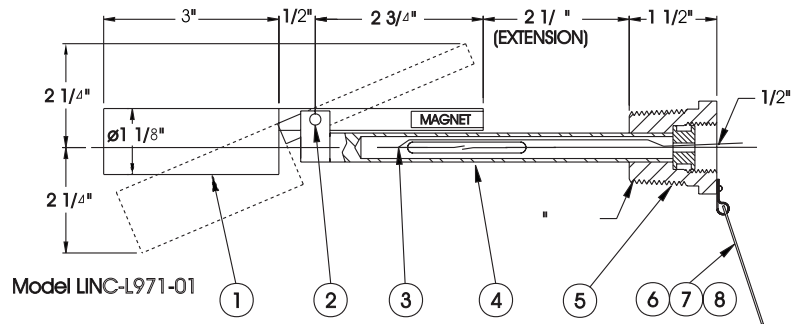

Model	L971-01 Series		Description	Material	Qty
Item	Part #				
1	21161		Float Arm Assembly	Polypropylene	1
2	21001		Pivot Pin	316 ss	1
3*	20416		Switch Cartridge	Sealed	1
4	30117		Body Assembly	316 ss	1
5	10087		Grommet	Nitrile	1
6	12972		Name Plate	316 ss	1
7	13060		Drive Screw	18-8 ss	1
8	13061		Clamp	18-8 ss	1

*Recommended spare

Model	L971-01-04 Series		Description	Material	Qty
Item	Part #				
1	21161		Float Arm Assembly	Polypropylene	1
2	21001		Pivot Pin	316 ss	1
3*	20416		Switch Cartridge	Sealed	1
4	30117		Body Assembly	316 ss	1
5	10087		Grommet	Nitrile	1
6	10867		Name Plate	316 ss	1
7	13060		Drive Screw	18-8 ss	1
8	13061		Clamp	18-8 ss	1
9	21593		Relay Assembly		1

*Recommended spare

—NOTES—

