

Frequency inverter

8200 vector

0.25 ... 90.0 kW

Created as a system

Global Drive



Lenze



Lenze | An introduction

Whatever drive system you have in mind, we can make it a reality.

Our “one-stop shop” enables us to offer you a complete range of reliable, high-performance electronic and mechanical drive products. Our product range includes frequency inverters, power converters, servo-controllers, variable speed drives and speed-transforming gears, motors as well as brakes and clutches. This makes Lenze the ideal supplier for your applications – not only for individual components, but also for complete drive systems, from project planning to setup and commissioning.

In addition, our global service and distribution network provides local customer service as well as fast and comprehensive after sales service. Our quality assurance system for development, production, sales and service is certified to DIN ISO 9001 : 2000. Our environmental management system is also certified to DIN ISO 14001. Our customers measure the quality of our products. It is our responsibility to meet their requirements. Our company policy, which places the customer at the centre of our focus, means that quality is always our top priority.

Why not find out for yourself?



System overview/Selection guide

Base controller and accessories

Mains



Cable protection
>> Page 4-4

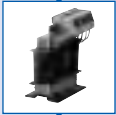

Mains choke
>> Page 4-10



RFI/Mains filters
>> Page 4-14



8200 vector
base controller
0.25.. 90 kW
>> Page 2-8

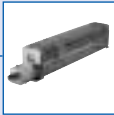

Brake resistor
>> Page 4-36



Motor filters
>> Page 4-24



Motor



The section “Product information – **Quick selection guide**” (page 1-8) contains a selection guide to help you find the right inverter for your application quickly and easily.

Automation components



Communication modules e.g. keypad or PROFIBUS
>> Page 3-6



Function modules e.g. standard I/O PT
>> Page 3-10



Drive PLC
>> Page 3-34



Extension boards
>> Page 3-41



Parameter setting software
>> Page 3-8



I/O terminals
>> Page 3-42



Human Machine Interface
>> Page 3-43

Partnership | Created as a system



Maximum power combined with high drive performance in a single universally applicable system: the **8200 vector frequency inverter range**. The modular product range can provide a solution which, as well as meeting the requirements of your individual drive tasks, is also cost-effective.



Global Drive

We can provide a complete and universally applicable system able to meet all your operational, diagnostics and communication needs in a user-friendly way. Developed specifically for use in day-to-day operations, the 8200 vector device range is part of our field-proven system comprising expert advice, training, support service and much more - features that really pay off.



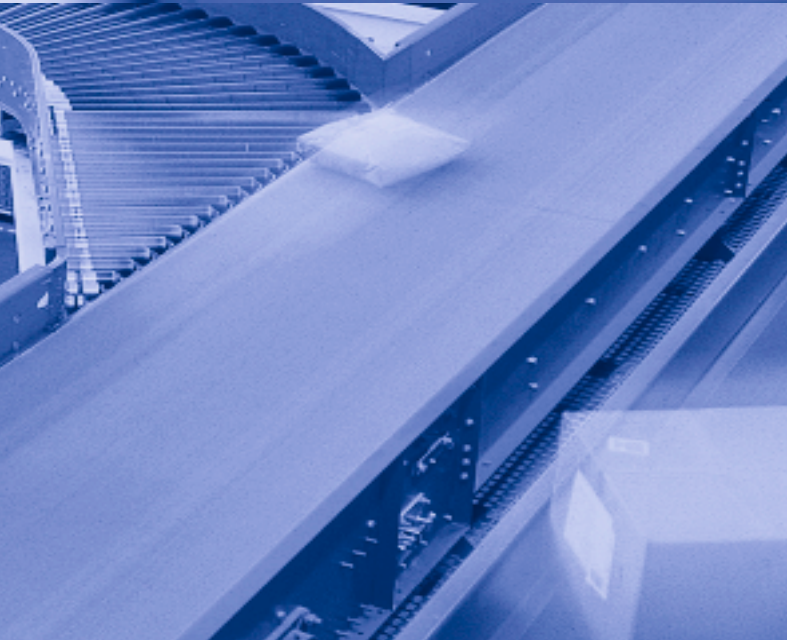
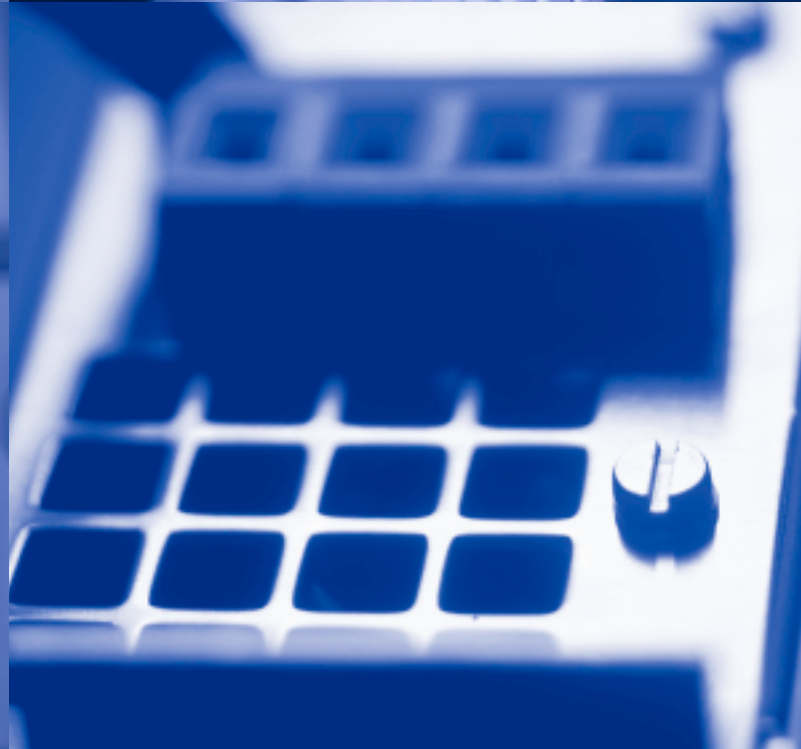

Contents | 8200 vector

		1
Product information	1-1	
Quick selection guide	1-8	
<hr/>		
		2
Base controllers	2-1	
<hr/>		
		3
Automation	3-1	
<hr/>		
		4
Accessories	4-1	
<hr/>		
		5
Application examples	5-1	
<hr/>		
		6
Services	6-1	
<hr/>		



Hans-Lenze-Str.1
D-31855_Aerzen

Lenze

Type: E82EV751_4C200

STANDARD PT
010 / 3A



ATTENTION

L'appareil est sous tension
pendant 180s après la
coupure de la tension réseau

WARNING

Device is live up to 180s after
removing mains voltage.



1 2 3 4 5
62 0 9 7 20 28 E1 E2 E3 E4 39 A1
62 0 9 7 20 28 E1 E2 E3 E4 39 A1 50

Product information | 8200 vector

List of abbreviations	1-2
Type code	1-3
Ordering data	1-4
Using the catalog	1-5
8200 vector – Created as a system	1-6
8200 vector quick selection guide	1-8

Product information

List of abbreviations

Abbreviations used in this catalog

U_{mains}	[V]	Mains voltage	AC	Alternating current/voltage
U_{DC}	[V]	DC voltage supply	DC	Direct current/voltage
U_M	[V]	Output voltage		
I_{mains}	[A]	Mains current	DIN	Deutsches Institut für Normung
I_r	[A]	Rated output current		
I_{max}	[A]	Maximum output current	EMC	Electromagnetic compatibility
I_{PE}	[mA]	Leakage current	EN	European standard
			IEC	International Electrotechnical Commission
P_r	[kW]	Rated motor power		
P_{loss}	[W]	Inverter power loss	IP	International Protection Code
P_{DC}	[kW]	Power in addition to that which can be drawn from the DC bus in power-adaptive operation	NEMA	National Electrical Manufacturers Association
S_N	[kVA]	Inverter output power		
M_N	[Nm]	Rated torque	VDE	Verband deutscher Elektrotechniker
f_{max}	[Hz]	Maximum frequency	CE	Communauté Européene
L	[mH]	Inductance	UL	Underwriters Laboratories
R	[Ω]	Resistance		



Type key

E **8** **2** **x** **V** **x** **x** **x** **K** **x** **C** **x** **x** **x**

E	Electronic product
8 2	8200 frequency inverter
E	Design Built-in unit
C	“Cold plate” technology (type-dependent) ¹⁾
D	Push-through technology (type-dependent) ¹⁾
V	Version Vector-controlled inverter
7 5 1	Power e. g. 750 W
7 5 2	e. g. 7500 W
1 1 3	e. g. 11,000 W
2	Mains voltage 230 V
4	400/500 V
	Device generation
0	Option Standard (0.25...11 kW)
1	IT system (15...90 kW) ¹⁾
2	without integrated filters
0	Standard
4	Safe stop (3...90 kW) ¹⁾
0	Not coated (0.25...11 kW)
1	Coated
3 0 2	With mains filters (15...90 kW) Operation at rated power ¹⁾
3 0 3	Operation at increased rated power ¹⁾

¹⁾ Available on request

Product Information

Ordering data – 8200 vector

We want to be sure that you receive the correct products in good time. In order to help us to do this, please make sure you provide the following information:

- Your address and ordering data
- Our order numbers/designations for each catalog product
- Your delivery data, i.e. delivery date and delivery address

How to order

You will find the order numbers/designations you require in this section (Quick selection guide) or on the relevant page in the product description.

- Make a photocopy of the fax order form which you will find on the last page of this catalog.
- Enter the order numbers/designations in the appropriate columns.
- Enter your customer details.
- Send the fax order form to your Lenze sales office.

You don't know where your Lenze sales office is?

No problem!

You will find all the information you need on the Internet at Lenze website.

We would be delighted to assist you.





This catalog introduces you to Lenze's extensive 8200 vector range of frequency inverters. In addition to the base controllers, a wide variety of application-specific accessories are available to meet the individual requirements of your drive system. Lenze can also provide components for automating your system, such as the Drive PLC controller with expansion options, programmable displays for process visualisation and much more – true system-based solutions. To help you to select the right components for your drive system, we have put together a basic configuration comprising an inverter and a terminal module, which you will find in the **quick selection guide on the following pages**.

This inverter configuration can be used to solve most common applications. If you require a different configuration, simply find the product you require in the relevant section and enter its designation in the fax order form.

The general table of contents will help you to find specific items.

Have fun making your selections!

The next section, "8200 vector – A model system" contains information about the essential features of and comprehensive functions offered by the 8200 vector.



8200 vector – Created as a system

The concept of the 8200 vector frequency inverter is based on a modular system of complementary components. Combined with a Lenze geared motor or a Lenze three-phase AC motor, it can be used to implement electronic variable speed drives for a multiplicity of applications.

Compact

Side-by-side mounting saves space in the control cabinet. Integrated filters (optional) simplify installation.

Flexible

The modular structure enables the inverters to be optimised for your application. This results in cost-effective but high-performance drive solutions. Whether as a “stand-alone” inverter with set value selection via potentiometer or a networked inverter with speed feedback in master/slave mode – the inverter functions can be adapted to suit every application.



Versatile

The range is completed by special assembly techniques such as push-through technology to reduce the heat generated in the control cabinet or “cold plate” technology, which enables a customer-specific heatsink to be used.



Uncomplicated

This range of inverters is characterised by its ease of control and operation combined with an extensive range of functions. A transparent menu structure and assisted commissioning using the Global Drive Control easy (GDC easy) parameterisation software enable the inverter to be parameterised and diagnosed quickly and easily. (Download via Internet)

Transparent

The keypad XT is used to display the operating parameters. 8 keys and a text display provide quick and easy access to the inverter parameters via the transparent menu structure. The keypad XT is also used for the purposes of status display and error diagnostics. In addition, its built-in memory can be used to transfer settings to other inverters.

User-friendly

The transparent and user-friendly drive documentation can provide answers to your questions quickly. We even have DOCcert (TÜV) certification to prove this.



Operational reliability

Configurable slip compensation can be employed to compensate load-dependent fluctuations in speed without having to apply complex speed feedback. The maximum current limiting function ensures stable operation at every operating point for both static and dynamic loads. A PTC resistor can be connected for motor protection.

Global application

The broad input voltage range of up to 500 V (+10%) means that your machine's installation location is all but irrelevant – wherever it may be in the world. As you would expect, the 8200 vector is certified to international standards.



Drive characteristics

- Power range 0.25 kW...7.5 kW 230 V/240 V (+10%)
0.55 kW...90 kW 400 V/500 V (+10%)
- Overload capacity 180% of rated torque for 60 seconds, from 15 kW 210% of rated torque for 3s
- V/f linear, V/f quadratic, vector control, sensorless torque control modes
- Chopper frequency 1, 2, 4, 8, 16 kHz
- Output frequency up to 650 Hz

Input and output terminals

- Up to 2 analog inputs, bipolar as an option (0-10 V, -10 V...+10 V, 0-20 mA, 4-20 mA; 10-bit resolution)
- Up to 2 analog outputs (0-10 V, 0-20 mA, 4-20 mA; 10-bit resolution)
- Up to 6 potential-free digital inputs with switchable logic
- Up to 2 digital outputs and one frequency output
- Up to 2 relay outputs (also for direct mains connection 240 V AC)
- Selection option for incremental encoder

Fieldbus communication

- RS232/485 serial interface; optical fibre as an option
- Bus interface to most common fieldbus systems (CAN, PROFIBUS-DP, INTERBUS, INTERBUS LOOP, LON, DeviceNet, CANopen, AS-Interface)

Protection functions

- Short-circuit-resistant, protected against earth faults during operation
- Configurable current limiting, warnings and error messages in the event of overcurrents
- Protected against overvoltages and undervoltages
- Warnings and error messages in the event of overtemperatures on the frequency inverter
- Input for PTC or thermal contact and I²t monitoring for motor protection
- Motor phase failure detection
- Integrated brake transistor (up to 11 kW)
- Integrated RFI filters to EN55011 class A or B (device-dependent)

Standard functions

- PID controller
- Flying restart with coasting motor
- Slip and mains voltage compensation
- Load loss/belt monitoring
- Smooth start/stop along S ramps
- DC braking
- Motor potentiometer
- 4 freely parameterisable parameter sets which can be switched online

Control and operation

- Keypad XT with display in plain text and menu structure
- Copy function with keypad for transferring inverter settings
- Password protection
- Global Drive Control easy control and parameterisation software (can be downloaded from the Internet)
- Spring-clamp terminals for cable cross-sections up to 1.5 mm² on all function modules with plug-in terminals
- Shield sheets for motor cable and control cables supplied with the frequency inverter

Certifications/Approvals

- UL, cUL, CE



Keypad XT

User-friendly menu structure and plain text display

Plug-in spring-clamp terminal strip

Shield sheet for control cables

Shield sheet for motor cables

Quick selection guide

Operation at rated power (normal operation)

In normal operation, the inverter is set for the rated power of the motor.

Note: During operation at increased rated power, a larger motor may be used under certain circumstances at the same inverter power as in normal operation, e.g. in pump and fan applications. Please use the quick selection guide on page 1-9 to make your selections for "Operation at increased rated power".

Supply voltage?		
230 V AC	400 V AC	500 V AC

Max. 20 m motor cable, radio interference level "A"?					
Yes	No	Yes	No	Yes	No

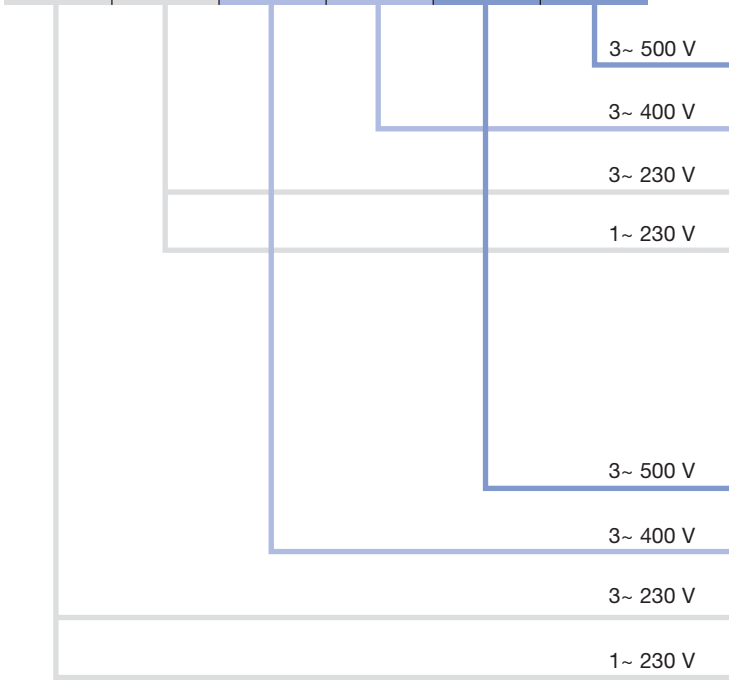

Base controllers without integrated EMC filters

- 400 V/500 V, 3-phase, without integrated EMC filters (see page 1-12)
- 400 V/500 V, 3-phase, without integrated EMC filters (see page 1-12)
- 230 V, 3-phase, without integrated EMC filters (see page 1-11)
- 230 V, single-phase, without integrated EMC filters (see page 1-10)

Base controllers with integrated EMC filters

- 500 V, 3-phase, with integrated EMC filters (see page 1-18)
- 400 V, 3-phase, with integrated EMC filters (see page 1-16)
- 230 V, 3-phase, with integrated EMC filters (see page 1-15)
- 230 V, 1-phase, with integrated EMC filters (see page 1-14)



Quick selection guide

Operation at increased rated power

During operation at increased rated power, a larger motor may be used under certain circumstances at the same inverter power as in normal operation. The inverter may be operated at increased rated power under the following conditions:

- In the mains voltage ranges specified
- Only 2 kHz or 4 kHz operating frequency
- Only with approved mains chokes, fuses and cable cross-sections

During operation at rated power (normal operation), the inverter is set for the rated power of the motor. Please use the quick selection guide on page 1-8 to make your selections for "Normal operation".

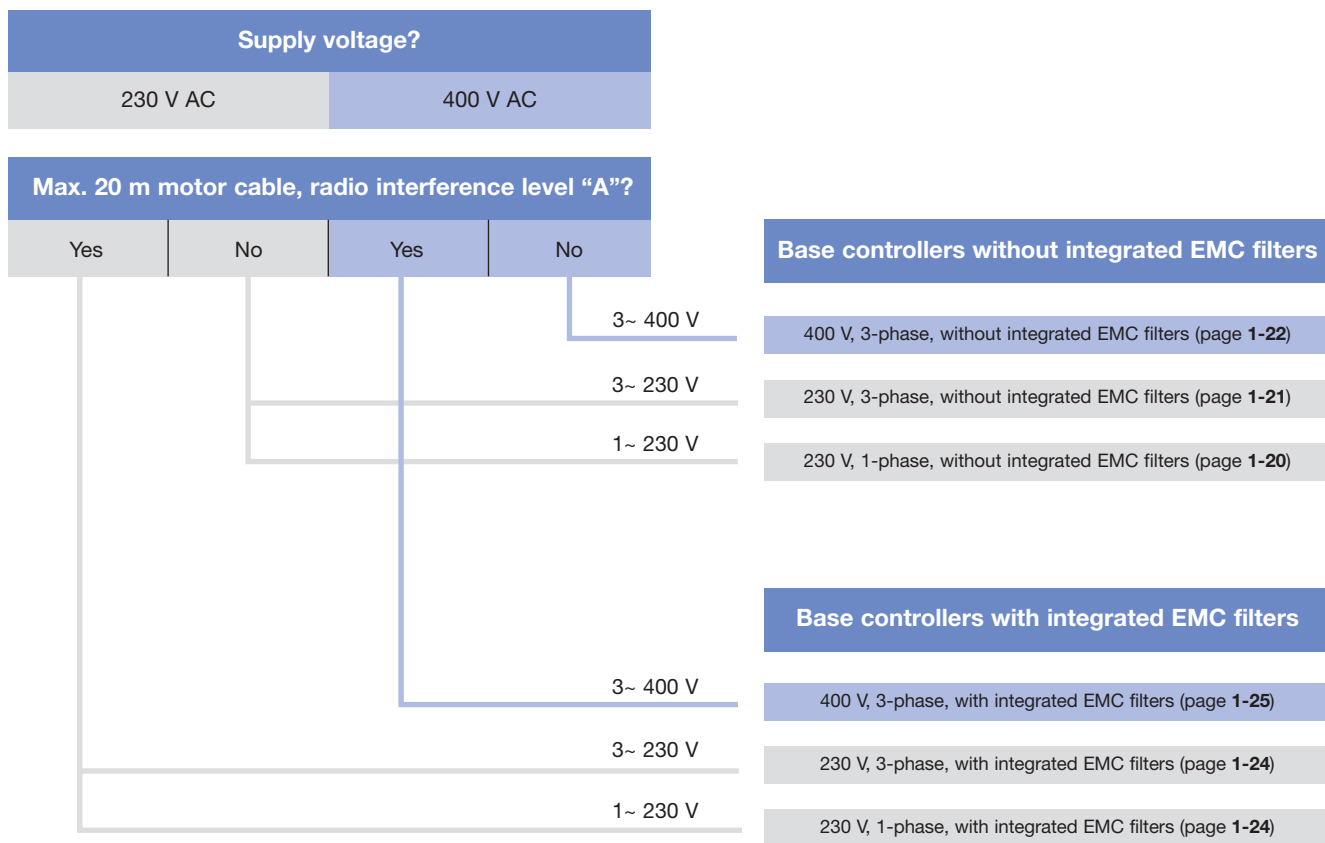

Product information

8200 vector quick selection guide

230 V, single-phase, normal operation, without integrated EMC filters					
	Motor power [kW]	0.25	0.37	0.55	Technical data
Essential	Frequency inverter (base controller)	E82EV251K2C200	E82EV371K2C200	E82EV551K2C200	Chapter 2
	Control via digital/analog I/O (Standard I/O PT function module) ¹⁾	E82ZAFSC010	E82ZAFSC010	E82ZAFSC010	Chapter 3
Optional	Control and diagnostics (Keypad XT operating module) ²⁾	EMZ9371BC			Chapter 3
	Mains choke	ELN1-0900H005		ELN1-0500H009	Chapter 4
	RFI filter	Motor cable up to 20 m, limiting value classes A and B	E82ZZ37112B200	E82ZZ75112B200	Chapter 4

230 V, single-phase, normal operation, without integrated EMC filters					
	Motor power [kW]	0.75	1.5	2.2	Technical data
Essential	Frequency inverter (base controller)	E82EV751K2C200	E82EV152K2C200	E82EV222K2C200	Chapter 2
	Control via digital/analog I/O (Standard I/O PT function module) ¹⁾	E82ZAFSC010	E82ZAFSC010	E82ZAFSC010	Chapter 3
	Mains choke	-	-	ELN1-0250H018	Chapter 4
Optional	Control and diagnostics (Keypad XT operating module) ²⁾	EMZ9371BC			Chapter 3
	Mains choke	ELN1-0900H005	ELN1-0250H018	-	Chapter 4
	RFI filter	Motor cable up to 20 m, limiting value classes A and B	E82ZZ37112B200	E82ZZ22212B200	Chapter 4

¹⁾ See chapter 3 for additional I/O function modules and modules for fieldbus networking

²⁾ See chapter 3 for additional communication modules

Product information

8200 vector quick selection guide



230 V, 3-phase, normal operation, without integrated EMC filters						
	Motor power [kW]	0.55	0.75	1.5	2.2	Technical data
Essential	Frequency inverter (base controller)	E82EV551K2C200	E82EV751K2C200	E82EV152K2C200	E82EV222K2C200	Chapter 2
	Control via digital/analog I/O (Standard I/O PT function module) ¹⁾	E82ZAFSC010	E82ZAFSC010	E82ZAFSC010	E82ZAFSC010	Chapter 3
Optional	Control and diagnostics (Keypad XT operating module) ²⁾	EMZ9371BC				Chapter 3
	Mains choke	E82ZL75132B		E82ZL22232B		Chapter 4
	RFI filter	E82ZZ75132B200		E82ZZ22232B200		Chapter 4
	Motor cable up to 20 m, Limiting value classes A and B					

230 V, 3-phase, normal operation, without integrated EMC filters						
	Motor power [kW]	3	4	5.5	7.5	Technical data
Essential	Base controller	E82EV302K2C200	E82EV402K2C200	E82EV552K2C200	E82EV752K2C200	Chapter 2
	Control via digital/analog I/O (Standard I/O PT function module) ¹⁾	E82ZAFSC010	E82ZAFSC010	E82ZAFSC010	E82ZAFSC010	Chapter 3
	Mains choke	-	-	-	ELN3-0088H035	Chapter 4
Optional	Control and diagnostics (Keypad XT operating module) ²⁾	EMZ9371BC				Chapter 3
	Mains choke	ELN3-0120H017		ELN3-0120H025	-	Chapter 4
	RFI filter	E82ZZ40232B200		E82ZZ75232B200		Chapter 4
	Motor cable up to 20 m, limiting value classes A and B					

¹⁾ See chapter 3 for additional I/O function modules and modules for fieldbus networking

²⁾ See chapter 3 for additional communication modules

Product information

8200 vector quick selection guide

400 V/500 V, 3-phase, normal operation, without integrated EMC filters							
	Motor power [kW]	0.55	0.75	1.5	2.2	Technical data	
Essential	Frequency inverter (base controller)	E82EV551 K4C200	E82EV751 K4C200	E82EV152 K4C200	E82EV222 K4C200	Chapter 2	
	Control via digital/analog I/O (Standard I/O PT function module) ¹⁾	E82ZAFSC010	E82ZAFSC010	E82ZAFSC010	E82ZAFSC010	Chapter 3	
Optional	Control and diagnostics (Keypad XT operating module) ²⁾	EMZ9371BC				Chapter 3	
	Mains choke	EZN3A1500H003		E82ZL22234B		Chapter 4	
	RFI filter	E82ZZ75134B200		E82ZZ22234B200		Chapter 4	
	Motor cable up to 20 m, Limiting value classes A and B						

400 V/500 V, 3-phase, normal operation, without integrated EMC filters							
	Motor power [kW]	3	4	5.5	7.5	11	Technical data
Essential	Frequency inverter (base controller)	E82EV302 K4C200	E82EV402 K4C200	E82EV552 K4C200	E82EV752 K4C200	E82EV112 K4C200	Chapter 2
	Control via digital/analog I/O (Standard I/O PT function module) ¹⁾	E82ZAFSC010	E82ZAFSC010	E82ZAFSC010	E82ZAFSC010	E82ZAFSC010	Chapter 3
	Mains choke		-	-	-	ELN3-0150H024	Chapter 4
Optional	Control and diagnostics (Keypad XT operating module) ²⁾	EMZ9371BC				Chapter 3	
	Mains choke	EZN3A0500H007	EZN3A0300H013		ELN3-0120H017	-	Chapter 4
	RFI filter	E82ZZ55234B200		E82ZZ11334B200		Chapter 4	
	Motor cable up to 20 m, Limiting value classes A and B						

¹⁾ See chapter 3 for additional I/O function modules and modules for fieldbus networking

²⁾ See chapter 3 for additional communication modules



400 V/500 V, 3-phase, normal operation, without integrated EMC filters							
	Motor power [kW]	15	22	30	45	Technical data	
Essential	Frequency inverter (base controller)	E82EV153 K4B201	E82EV223 K4B201	E82EV303 K4B201	E82EV453 K4B201	Chapter 2	
	Control via digital/analog I/O (Standard I/O PT function module) ²⁾	E82ZAFSC010	E82ZAFSC010	E82ZAFSC010	E82ZAFSC010	Chapter 3	
	Mains choke	-	ELN3-0075H045	ELN3-0055H055	ELN3-0038H085	Chapter 4	
Optional	Control and diagnostics (Keypad XT operating module) ³⁾	EMZ9371BC				Chapter 3	
	Mains choke	ELN3-088H035	-	-	-	Chapter 4	
	Mains filter ¹⁾	Motor cable up to 50 m, limiting value class A (limiting value class B: 10 m); mains filter (base)	E82ZN22334B230		E82ZN30334B230	E82ZN45334B230	Chapter 4
		Motor cable up to 50 m, limiting value class B Mains filter (integrated)	EZN3B0110H030	EZN3B0080H042	EZN3B0055H060	EZN3B0037H090	Chapter 4

400 V/500 V, 3-phase, normal operation, without integrated EMC filters							
	Motor power [kW]	55	75	90		Technical data	
Essential	Frequency inverter (base controller)	E82EV553 K4B201	E82EV753 K4B201	E82EV903 K4B201		Chapter 2	
	Control via digital/analog I/O (Standard I/O PT function module) ²⁾	E82ZAFSC010	E82ZAFSC010	E82ZAFSC010		Chapter 3	
	Mains choke	ELN3-0027H105	ELN3-0022H130	ELN3-0017H170		Chapter 4	
Optional	Control and diagnostics (Keypad XT operating module) ³⁾	EMZ9371BC				Chapter 3	
	Mains choke	-	-	-		Chapter 4	
	Mains filter ¹⁾	Motor cable up to 50 m, limiting value class A (limiting value class B: 10 m); mains filter (base)	E82ZN55334B230	E82ZN75334B230	E82ZN90334B230		Chapter 4
		Motor cable up to 50 m, limiting value class B Mains filter (integrated)	EZN3B0033H110	EZN3B0022H150	EZN3B0017H200		Chapter 4

¹⁾ A mains choke is not required if a mains filter is used
(line filter: = RFI filter with integrated mains choke)

²⁾ See chapter 3 for additional I/O function modules and modules for field-bus networking

³⁾ See chapter 3 for additional communication modules

Product information

8200 vector quick selection guide

230 V, single-phase, normal operation, with integrated EMC filters ³⁾					
	Motor power [kW]	0.25	0.37	0.5	Technical data
Essential	Frequency inverter (base controller)	E82EV251K2C	E82EV371K2C	E82EV551K2C	Chapter 2
	Control via digital/analog I/O (Standard I/O PT function module) ¹⁾	E82ZAFSC010	E82ZAFSC010	E82ZAFSC010	Chapter 3
Optional	Control and diagnostics (Keypad XT operating module) ²⁾	EMZ9371BC			Chapter 3
	Mains choke	ELN1-0900H005		ELN1-0500H009	Chapter 4

230 V, single-phase, normal operation, with integrated EMC filters ³⁾					
	Motor power [kW]	0.75	1.5	2.2	Technical data
Essential	Frequency inverter (base controller)	E82EV751K2C	E82EV152K2C	E82EV222K2C	Chapter 2
	Control via digital/analog I/O (Standard I/O PT function module) ¹⁾	E82ZAFSC010	E82ZAFSC010	E82ZAFSC010	Chapter 3
	Mains choke	-	-	ELN1-0250H018	Chapter 4
Optional	Control and diagnostics (Keypad XT operating module) ²⁾	EMZ9371BC			Chapter 3
	Mains choke	ELN1-0500H009	ELN1-0250H018	-	Chapter 4

¹⁾ See chapter 3 for additional I/O function modules and modules for fieldbus networking

²⁾ See chapter 3 for additional communication modules

³⁾ Limiting value class A up to 20 m motor cable length or limiting value class B, depending on controller type and chopper frequency



230 V, 3-phase, normal operation, with integrated EMC filters ³⁾						
	Motor power [kW]	0.55	0.75	1.5	2.2	Technical data
Essential	Frequency inverter (base controller)	E82EV551K2C	E82EV751K2C	E82EV152K2C	E82EV222K2C	Chapter 2
	Control via digital/analog I/O (standard I/O PT function module) ¹⁾	E82ZAFSC010	E82ZAFSC010	E82ZAFSC010	E82ZAFSC010	Chapter 3
Optional	Control and diagnostics (Keypad XT operating module) ²⁾	EMZ9371BC				Chapter 3
	Mains choke	E82ZL75132B		E82ZL22232B		Chapter 4

230 V, 3-phase, normal operation, with integrated EMC filters ³⁾						
	Motor power [kW]	3	4	5.5	7.5	Technical data
Essential	Frequency inverter (base controller)	E82EV302K2C	E82EV402K2C	E82EV552K2C	E82EV752K2C	Chapter 2
	Control via digital/analog I/O (standard I/O PT function module) ¹⁾	E82ZAFSC010	E82ZAFSC010	E82ZAFSC010	E82ZAFSC010	Chapter 3
	Mains choke	-	-	-	ELN3-0088H035	Chapter 4
Optional	Control and diagnostics (Keypad XT operating module) ²⁾	EMZ9371BC				Chapter 3
	Mains choke	ELN3-0120H017		ELN3-0120H025	-	Chapter 4

¹⁾ See chapter 3 for additional I/O function modules and modules for fieldbus networking

²⁾ See chapter 3 for additional communication modules

³⁾ Limiting value class A up to 20 m motor cable length or limiting value class B, depending on controller type and chopper frequency

Product information

8200 vector quick selection guide

400 V, 3-phase, normal operation, with integrated EMC filters ³⁾						
	Motor power [kW]	0.55	0.75	1.5	2.2	Technical data
Essential	Frequency inverter (base controller)	E82EV551K4C	E82EV751K4C	E82EV152K4C	E82EV222K4C	Chapter 2
	Control via digital/analog I/O (standard I/O PT function module) ¹⁾	E82ZAFSC010	E82ZAFSC010	E82ZAFSC010	E82ZAFSC010	Chapter 3
Optional	Control and diagnostics (Keypad XT operating module) ²⁾	EMZ9371BC				Chapter 3
	Mains choke	EZN3A1500H003		E82ZL22234B		Chapter 4

400 V, 3-phase, normal operation, with integrated EMC filters ³⁾							
	Motor power [kW]	3	4	5.5	7.5	11	Technical data
Essential	Frequency inverter (base controller)	E82EV302K4C	E82EV402K4C	E82EV552K4C	E82EV752K4C	E82EV112K4C	Chapter 2
	Control via digital/analog I/O (standard I/O PT function module) ¹⁾	E82ZAFSC010	E82ZAFSC010	E82ZAFSC010	E82ZAFSC010	E82ZAFSC010	Chapter 3
	Mains choke	-	-	-	-	ELN3-150H024	Chapter 4
Optional	Control and diagnostics (Keypad XT operating module) ²⁾	EMZ9371BC				Chapter 3	
	Mains choke	EZN3A0500H007	EZN3A0300H013		ELN3-0120H017	-	Chapter 4

¹⁾ See chapter 3 for additional I/O function modules and modules for fieldbus networking

²⁾ See chapter 3 for additional communication modules

³⁾ Limiting value class A up to 20 m motor cable length or limiting value class B, depending on controller type and chopper frequency



400 V, 3-phase, normal operation, with integrated mains filters ³⁾						
	Motor power [kW]	15	22	30	45	Technical data
Essential	Frequency inverters with mounted mains filter (base controller)	E82EV153K4B302 ⁴⁾	E82EV223K4B302 ⁴⁾	E82EV303K4B302 ⁴⁾	E82EV453K4B302 ⁴⁾	Chapter 2
	Control via digital/analog I/O (standard I/O PT function module) ¹⁾	E82ZAFSC010	E82ZAFSC010	E82ZAFSC010	E82ZAFSC010	Chapter 3
Optional	Control and diagnostics (Keypad XT operating module) ²⁾	EMZ9371BC				Chapter 3

400 V, 3-phase, normal operation, with integrated mains filters ³⁾					
	Motor power [kW]	55	75	90	Technical data
Essential	Frequency inverters with mounted mains filter (base controller)	EE82EV553K4B302 ⁴⁾	E82EV753K4B302 ⁴⁾	E82EV903K4B302 ⁴⁾	Chapter 2
	Control via digital/analog I/O (standard I/O PT function module) ¹⁾	E82ZAFSC010	E82ZAFSC010	E82ZAFSC010	Chapter 3
Optional	Control and diagnostics (Keypad XT operating module) ²⁾	EMZ9371BC			Chapter 3

- ¹⁾ See chapter 3 for additional I/O function modules and modules for fieldbus networking
²⁾ See chapter 3 for additional communication modules
³⁾ Limiting value class A up to 50 m or limiting value class B up to 10 m motor cable length depending on the chopper frequency
⁴⁾ Delivery will be effected upon request (in preparation)

Product information

8200 vector quick selection guide

500 V, 3-phase, normal operation, with integrated EMC filters ³⁾						
	Motor power [kW]	0.55	0.75	1.5	2.2	Technical data
Essential	Frequency inverter (base controller)	E82EV551K4C	E82EV751K4C	E82EV152K4C	E82EV222K4C	Chapter 2
	Control via digital/analog I/O (standard I/O PT function module) ¹⁾	E82ZAFSC010	E82ZAFSC010	E82ZAFSC010	E82ZAFSC010	Chapter 3
	Brake resistor	ERBM470R100W ⁴⁾	ERBM470R100W ⁴⁾	ERBM370R150W ⁴⁾	ERBM240R200W ⁴⁾	Chapter 4
Optional	Control and diagnostics (Keypad XT operating module) ²⁾	EMZ9371BC				Chapter 3
	Mains choke	EZN3A1500H003		E82ZL22234B		Chapter 4

500 V, 3-phase, normal operation, with integrated EMC filters ³⁾							
	Motor power [kW]	3	4	5.5	7.5	11	Technical data
Essential	Frequency inverter (base controller)	E82EV302K4C	E82EV402K4C	E82EV552K4C	E82EV752K4C	E82EV112K4C	Chapter 2
	Control via digital/analog I/O (standard I/O PT function module) ¹⁾	E82ZAFSC010	E82ZAFSC010	E82ZAFSC010	E82ZAFSC010	E82ZAFSC010	Chapter 3
	Mains choke	-	-	-	-	ELN3-150H024	Chapter 4
Optional	Control and diagnostics (Keypad XT operating module) ²⁾	EMZ9371BC					Chapter 3
	Mains choke	EZN3A0500H007	EZN3A0300H013		ELN3-0120H017	-	Chapter 4

¹⁾ See chapter 3 for additional I/O function modules and modules for fieldbus networking

²⁾ See chapter 3 for additional communication modules

³⁾ Limiting value class A up to 20 m motor cable length or limiting value class B, depending on controller type and chopper frequency

⁴⁾ For mains voltages from 484 V (-0 %) ... 550 V (+0 %): Operation is only permitted with brake resistor. (As an alternative, a frequency inverter without integrated EMC filter can be used – see pages 1-12)



500 V, 3-phase, normal operation, with integrated mains filters ³⁾						
	Motor power [kW]	15	22	30	45	Technical data
Essential	Frequency inverters with mounted mains filter (base controller)	E82EV153K4B302	E82EV223K4B302	E82EV303K4B302	E82EV453K4B302	Chapter 2
	Control via digital/analog I/O (standard I/O PT function module) ¹⁾	E82ZAFSC010	E82ZAFSC010	E82ZAFSC010	E82ZAFSC010	Chapter 3
Optional	Control and diagnostics (Keypad XT operating module) ²⁾	EMZ9371BC				Chapter 3

500 V, 3-phase, normal operation, with integrated mains filters ³⁾					
	Motor power [kW]	55	75	90	Technical data
Essential	Frequency inverters with mounted mains filter (base controller)	EE82EV553K4B302	E82EV753K4B302	E82EV903K4B302	Chapter 2
	Control via digital/analog I/O (standard I/O PT function module) ¹⁾	E82ZAFSC010	E82ZAFSC010	E82ZAFSC010	Chapter 3
Optional	Control and diagnostics (Keypad XT operating module) ²⁾	EMZ9371BC			Chapter 3

¹⁾ See chapter 3 for additional I/O function modules and modules for fieldbus networking

²⁾ See chapter 3 for additional communication modules

³⁾ Limiting value class A up to 50 m or limiting value class B up to 10 m motor cable length depending on the chopper frequency

Product information

8200 vector quick selection guide

230 V, single-phase, increased rated power, without integrated EMC filters						
	Motor power [kW]	0.37	0.75	1.1	2.2	Technical data
Essential	Frequency inverter (base controller)	E82EV251K2C200	E82EV551K2C200	E82EV751K2C200	E82EV152K2C200	Chapter 2
	Control via digital/analog I/O (Standard I/O PT function module) ¹⁾	E82ZAFSC010	E82ZAFSC010	E82ZAFSC010	E82ZAFSC010	Chapter 3
	Mains choke	-	-	ELN1-0500H009	-	Chapter 4
Optional	Control and diagnostics (Keypad XT operating module) ²⁾	EMZ9371BC				Chapter 3
	Mains choke	ELN1-0900H005	ELN1-0500H009	-	ELN1-0250H018	Chapter 4
	RFI filter	Motor cable up to 20 m, Limiting value classes A and B	E82ZZ37112B200	E82ZZ75112B200	E82ZZ22212B200	Chapter 4

¹⁾ See chapter 3 for additional I/O function modules and modules for fieldbus networking

²⁾ See chapter 3 for additional communication modules



230 V, 3-phase, increased rated power, without integrated EMC filters								
	Motor power [kW]	0.75	1.1	2.2	4	7.5	Technical data	
Essential	Frequency inverter (base controller)	E82EV551 K2C200	E82EV751 K2C200	E82EV152 K2C200	E82EV302 K2C200	E82EV552 K2C200	Chapter 2	
	Control via digital/analog I/O (Standard I/O PT function module) ¹⁾	E82ZAFSC010	E82ZAFSC010	E82ZAFSC010	E82ZAFSC010	E82ZAFSC010	Chapter 3	
	Mains choke	-	E82ZL75132B	-	-	ELN3-0088H035	Chapter 4	
Optional	Control and diagnostics (Keypad XT operating module) ²⁾	EMZ9371BC						Chapter 3
	Mains choke	E82ZL75132B	-	E82ZL22232B	ELN3-0120H017	-	Chapter 4	
	RFI filter	Motor cable up to 20 m, Limiting value classes A and B	E82ZZ75132B200		E82ZZ22232B200	E82ZZ40232B200	E82ZZ75232B200	Chapter 4

¹⁾ See chapter 3 for additional I/O function modules and modules for fieldbus networking

²⁾ See chapter 3 for additional communication modules

Product information

8200 vector quick selection guide

400 V, 3-phase, increased rated power, without integrated EMC filters							
	Motor power [kW]	0.75	1.1	3	4	5.5	Technical data
Essential	Frequency inverter (base controller)	E82EV551 K4C200	E82EV751 K4C200	E82EV222 K4C200	E82EV302 K4C200	E82EV402 K4C200	Chapter 2
	Control via digital/analog I/O (Standard I/O PT function module) ¹⁾	E82ZAFSC010	E82ZAFSC010	E82ZAFSC010	E82ZAFSC010	E82ZAFSC010	Chapter 3
	Mains choke	-	EZN3A1500H003	E82ZL22234B	-	EZN3A0300H013	Chapter 4
Optional	Control and diagnostics (Keypad XT operating module) ²⁾	EMZ9371BC					Chapter 3
	Mains choke	EZN3A1500H003	-	-	EZN3A0300H013	-	Chapter 4
	RFI filter	Motor cable up to 20 m, Limiting value classes A and B	E82ZZ75134B200	E82ZZ22234B200	E82ZZ55234B200		Chapter 4

¹⁾ See chapter 3 for additional I/O function modules and modules for fieldbus networking

²⁾ See chapter 3 for additional communication modules



400 V, 3-phase, increased rated power, without integrated EMC filters							
	Motor power [kW]	22	30	37	55	Technical data	
Essential	Frequency inverter (base controller)	E82EV153 K4B201	E82EV223 K4B201	E82EV303 K4B201	E82EV453 K4B201	Chapter 2	
	Control via digital/analog I/O (Standard I/O PT function module) ²⁾	E82ZAFSC010	E82ZAFSC010	E82ZAFSC010	E82ZAFSC010	Chapter 3	
	Mains choke	ELN3-0075H045	ELN3-0055H055	ELN3-0055H055	ELN3-0027H105	Chapter 4	
Optional	Control and diagnostics (Keypad XT operating module) ³⁾	EMZ9371BC				Chapter 3	
	Mains filter ¹⁾	Motor cable up to 50 m, limiting value class A (limiting value class B: 10 m); mains filter (base)	E82ZN22334B230	E82ZN30334B230	-	-	Chapter 4
		Motor cable up to 50 m, limiting value class B Mains filter (integrated)	EZN3B0080H042	EZN3B0060H054	EZN3B0055H060	EZN3B0030H110	Chapter 4

400 V, 3-phase, increased rated power, without integrated EMC filters						
	Motor power [kW]	75	90	110		Technical data
Essential	Frequency inverter (base controller)	E82EV553K4B201	E82EV753K4B201	E82EV903K4B201		Chapter 2
	Control via digital/analog I/O (Standard I/O PT function module) ²⁾	E82ZAFSC010	E82ZAFSC010	E82ZAFSC010		Chapter 3
	Mains choke	ELN3-0022H130	ELN3-0017H170	ELN3-0014H200		Chapter 4
Optional	Control and diagnostics (Keypad XT operating module) ³⁾	EMZ9371BC				Chapter 3
	Mains filter ¹⁾	Motor cable up to 50 m, limiting value class A (limiting value class B: 10 m); mains filter (base)	-	E82ZN90334B230	-	Chapter 4
		Motor cable up to 50 m, limiting value class B Mains filter (integrated)	-	EZN3B0022H150	EZN3B0017H200	Chapter 4

¹⁾ A mains choke is not required if a mains filter is being used
(mains filter: = RFI filter with integrated mains choke)

²⁾ See chapter 3 for additional I/O function modules and modules for fieldbus networking

³⁾ See chapter 3 for additional communication modules

Product information

8200 vector quick selection guide

230 V, single-phase, increased rated power, with integrated EMC filters ³⁾

	Motor power [kW]	0.37	0.75	1.1	2.2	Technical data
Essential	Frequency inverter (base controller)	E82EV251K2C	E82EV551K2C	E82EV751K2C	E82EV152K2C	Chapter 2
	Control via digital/analog I/O (standard I/O PT function module) ¹⁾	E82ZAFSC010	E82ZAFSC010	E82ZAFSC010	E82ZAFSC010	Chapter 3
	Mains choke	-	-	ELN1-0500H009	-	Chapter 4
Optional	Control and diagnostics (Keypad XT operating module) ²⁾	EMZ9371BC				Chapter 3
	Mains choke	ELN1-0900H005	ELN1-0500H009	-	ELN1-0250H018	Chapter 4

230 V, 3-phase, increased rated power, with integrated EMC filters ³⁾

	Motor power [kW]	0.75	1.1	2.2	4	7.5	Technical data
Essential	Frequency inverter (base controller)	E82EV551K2C	E82EV751K2C	E82EV152K2C	E82EV302K2C	E82EV552K2C	Chapter 2
	Control via digital/analog I/O (standard I/O PT function module) ¹⁾	E82ZAFSC010	E82ZAFSC010	E82ZAFSC010	E82ZAFSC010	E82ZAFSC010	Chapter 3
	Mains choke	-	E82ZL75132B	-	-	ELN3-0088H035	Chapter 4
Optional	Control and diagnostics (Keypad XT operating module) ²⁾	EMZ9371BC					Chapter 3
	Mains choke	E82ZL75132B	-	E82ZL22232B	ELN3-0120H017	-	Chapter 4

¹⁾ See chapter 3 for additional I/O function modules and modules for fieldbus networking

²⁾ See chapter 3 for additional communication modules

³⁾ Limiting value class A up to 20 m motor cable length or limiting value class B, depending on controller type and chopper frequency



400 V, 3-phase, increased rated power, with integrated EMC filters ³⁾							
	Motor power [kW]	0.75	1.1	3	4	5.5	Technical data
Essential	Frequency inverter (base controller)	E82EV551K4C	E82EV751K4C	E82EV222K4C	E82EV302K4C	E82EV402K4C	Chapter 2
	Control via digital/analog I/O (standard I/O PT function module) ¹⁾	E82ZAFSC010	E82ZAFSC010	E82ZAFSC010	E82ZAFSC010	E82ZAFSC010	Chapter 3
	Mains choke	-	EZN3A1500H003	E82ZL22234B	-	EZN3A0300H013	Chapter 4
Optional	Control and diagnostics (Keypad XT operating module) ²⁾	EMZ9371BC					Chapter 3
	Mains choke	EZN3A1500H003	-	-	EZN3A0300H013	-	Chapter 4

400 V, 3-phase, increased rated power, with integrated mains filters ⁴⁾					
	Motor power [kW]	22	30	90	Technical data
Essential	Frequency inverter (base controller)	E82EV153K4B303 ⁵⁾	E82EV223K4B303 ⁵⁾	E82EV753K4B303 ⁵⁾	Chapter 2
	Control via digital/analog I/O (Standard I/O PT function module) ¹⁾	E82ZAFSC010	E82ZAFSC010	E82ZAFSC010	Chapter 3
Optional	Control and diagnostics (Keypad XT operating module) ²⁾	EMZ9371BC			Chapter 3

¹⁾ See chapter 3 for additional I/O function modules and modules for fieldbus networking

²⁾ See chapter 3 for additional communication modules

³⁾ Limiting value class A up to 20 m motor cable length or limiting value class B, depending on controller type and chopper frequency

⁴⁾ Limiting value class A up to 50 m or limiting value class B up to 10 m motor cable length depending on the chopper frequency

⁵⁾ Delivery will be effected upon request (in preparation)



Base controllers | 8200 vector

Overview 2-3

Technical data 2-4

**Operation at rated power
(normal operation)** 2-8

Ratings at 230 V mains voltage 2-8

Ratings at 400 V mains voltage 2-12

Ratings at 500 V mains voltage 2-18

Operation at increased rated power 2-24

Ratings at 230 V mains voltage 2-24

Ratings at 400 V mains voltage 2-26

Mounting and assembly 2-30

General information 2-30

Mounting with standard fixtures
(scope of supply) 2-31

Mounting with a swivel bracket (accessories) 2-37

Mounting on DIN rail 2-38

Special designs 2-39

“Cold plate” technology 2-39

Push-through technology 2-44

Special versions 2-50

Version for “safe stop” safety technology 2-50

Version for isolated supply systems (IT systems) 2-51

Select the base controllers for your application on the following pages. The base controller is only supplied with one blanking plate. Two interfaces (three drives > 15 kW) enable the inverter to be fitted with control terminal modules or various bus modules as required.

Information about the modules (function and communication modules) can be found in the Automation chapter, page 3-1.

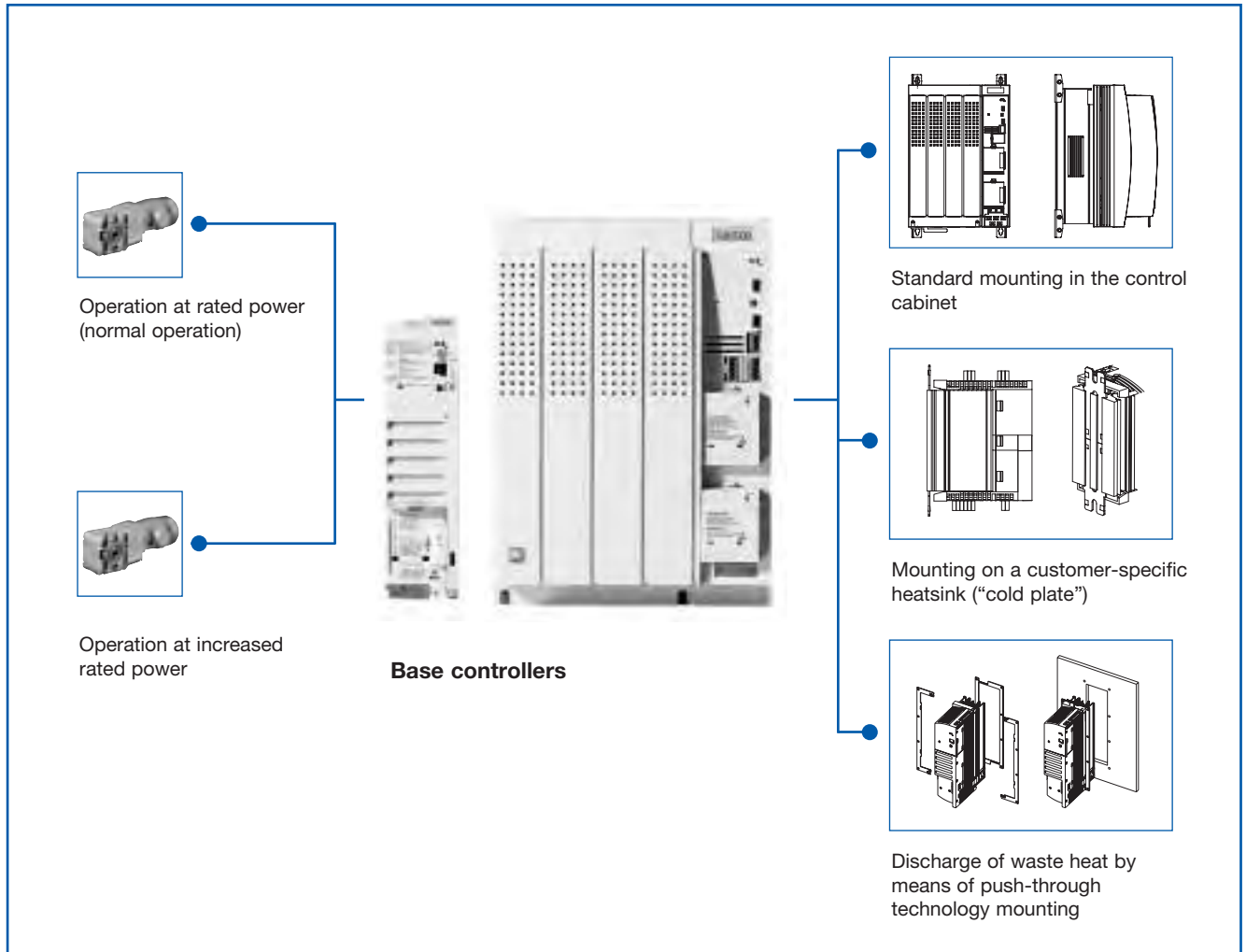

In normal operation, the inverter is set for the rated power of the motor. In this mode, the 8200 vector is suitable for a multiplicity of applications.

Under certain conditions, the 8200 vector can be operated at increased power, i.e. the inverter runs with a higher power motor. Typical applications include those involving pumps and fans with quadratic V/f characteristic.

Special designs enable the heat generated in the control cabinet to be reduced. In the “cold plate” special design (not available for all frame sizes), the base controller is supplied without a heatsink and can be mounted on a customer-specific heatsink (e.g. an oil or water cooler). In the “push-through technology” special design, the base controller is mounted in the control cabinet in such a way that the heatsink is located on the exterior of the cabinet.

The “IT system” special version permits installation in three-phase isolated supply systems. The electric strength of the base controllers is ensured even in the event of a single-phase short circuit on the supply system. In the “safe stop” special version, the base controller can be integrated into a safety system where it can replace additional safety components.

More detailed information can be found in the relevant sections.

Information about mains chokes, brake resistors and much more can be found in the “Accessories” chapter.

Base controllers

Technical data

Standards and application conditions

Conformity	CE	Low voltage directive (73/23/EEC)
Approvals	UL 508C	Underwriter Laboratories (File No. E132659) Power conversion equipment
Max. permissible motor cable length	At rated mains voltage and operating frequency of 8 kHz without additional output filters	
	Shielded	50 m
	Unshielded	100 m
Vibration resistance	Accelerational stability up to 0.7g (Germanischer Lloyd, general conditions)	
Climatic conditions	Class 3K3 to EN 50178 (without condensation, average relative humidity 85%)	
Pollution degree	VDE 0110 Part 2 pollution degree 2	
Packaging (DIN 4180)	Dust packaging	
Permissible temperature ranges		
	Transport	-25°C...+70°C
	Storage	-25°C...+60°C
	Operation	-10°C...+55°C
		-10°C...+50°C (8200 vector 15...90 kW only)
		At temperatures of +40°C, the rated output current should be derated by 2.5%/°C.
Permissible installation height	0..4000 m above sea level	The rated output current should be derated by 5%/1000 m above 1000 m above sea level.
Mounting position	Vertical	
Mounting clearances		
	Above/below	≥100 mm
	To the side	Mounted at intervals of 3 mm
DC bus operation	Possible, except E82EV251K2C and E82EV371K2C	

General electrical data

EMC	Compliance with requirements to EN 61800-3/A11		
Noise emissions	Compliance with threshold classes A and B to EN 55011		
	0.25...11 kW	E82xVxxxKxC0xx without additional filters E82xVxxxKxC2xx with external filters	
	15...90 kW	E82EVxxxK4B3xx without additional filters E82xVxxxK4B2xx with external filters	
Noise immunity	Requirements to EN 61800-3 incl. A11 noise immunity		
	Requirements	Standard Intensity of tests	
	ESD	EN 61000-4-2	3, i.e. 8 kV with air discharge, 6 kV with contact discharge
	Conducted high frequency	EN 61000-4-6	150 kHz ...80 MHz, 10 V/m 80% AM (1kHz)
	HF field (housing)	EN 61000-4-3	80 MHz ...1000 MHz, 10 V/m 80% AM (1kHz)
	Burst	EN 61000-4-4	3/4, i.e. 2 kV/5 kHz
	Surge (voltage surge on power cable)	EN 61000-4-5	3, i.e. 1.2/50 µs, 1 kV phase-phase, mains cable) 2 kV phase-PE
Insulation strength	Overvoltage category III to VDE 0110		
Leakage current to PE (to EN 50178)	> 3.5 mA, i.e. fixed installation required, PE must be reinforced		
Degree of protection	IP 20		
Protective measures against	Short circuit, short to earth (protected against short to earth during operation, limited protection against short to earth on power-up), overvoltage, motor instability, motor stalling, motor overtemperature (input for PTC or thermal contact, I ² t monitoring)		
Total insulation of control circuits	Mains isolation: Double/reinforced insulation to EN 50178		
Permissible mains systems	Operation on TT systems, TN systems or systems with earthed neutral without additional measures		
	Operation on IT systems only possible with a variant		
Operation on public mains supplies	Limits for harmonic currents to EN 61000-3-2		
	Total power on mains	Adherence to requirements ¹⁾	
	<0.5 kW	With mains choke	
	0.5 kW...1 kW	With active filter (currently in development)	
	>1 kW	Without additional measures	

¹⁾ The additional measures listed enable the drive controller alone to meet the requirements of EN 61000-3-2. Responsibility for adherence to requirements on the part of the machine/system lies with the machine/system manufacturer.

Base controllers

Technical data

Inputs and outputs

Analog inputs Analog outputs	With standard I/O	1 input, bipolar as an option 1 output
	With application I/O	2 inputs, bipolar as an option 2 outputs
Digital inputs Digital outputs	With standard I/O	4 inputs, 1 optional single-track frequency input 0...10 kHz; two-track 0...1 kHz 1 input for controller inhibit, 1 output
	With application I/O	6 inputs, 1 optional single/double-track frequency input 0...100 kHz; 1 input for controller inhibit, 2 outputs, 1 frequency output 50 Hz...10 kHz
Scan times	Digital inputs	1 ms
	Digital outputs	4 ms
	Analog inputs	2 ms
	Analog outputs	4 ms (filter time: $\tau = 10$ ms)
Relay output	0.25...11 kW	1 relay output 250 V AC/3 A, 24 V DC/2 A ...240 V/0.16 A (changeover contact)
	15...90 kW	2 relay outputs 250 V AC/3 A, 24 V DC/2 A ...240 V/0.22 A (changeover contact)
Generator mode	0.25...11 kW	Integrated brake transistor
	15...90 kW	With brake chopper 8253 or 9352

Open and closed-loop control

Open-loop and closed-loop control methods	V/f characteristic control (linear/quadratic), vector control torque provision	
Chopper frequency	0.25 ...11 kW	2 kHz,4 kHz,8 kHz,16 kHz
	15...90 kW	1 kHz, 2 kHz, 4 kHz, 8 kHz, 16 kHz, either optimised for noise or power loss
Torque characteristics	Maximum torque 0.25 ...11 kW	1.8 x M _r for 60 s If motor rated power = drive controller Rated power
	Maximum torque 15 ...90 kW	1.8 x M _r for 60 s 2.1 x M _r for 3 s after controller enable
	Setting range	1 :10 in speed range 3... 50 Hz, accuracy < 8%
	Torque/speed characteristic	
Sensorless speed control	Minimum Output frequency	1.0 Hz (0 ...M _r)
	Setting range	1 :50 Related to 50 Hz and M _r
	Accuracy	±0.5%
	Cyclic running	± 0.1 Hz in speed range 3... 50 Hz
Output frequency	Range	- 650 Hz... + 650 Hz
	absolute resolution	0.02 Hz
	normalised resolution	Parameter data: 0.01%, process data: 0.006% (= 2 ⁻¹⁴)
Digital setpoint preselection	Accuracy	± 0.005 Hz (= ± 100 ppm)
Analog setpoint preselection	Linearity	±0.5% related to momentary value
	Temp. sensitivity	+0.3% (0...+60°C) related to momentary value
	Offset	±0%
	A/D converter	10-bit resolution A/D converter
	Error 1 digit	≅ 0.1% related to upper range value

Base controllers

Operation at rated power (normal operation)

Ratings at 230 V mains voltage

Typical motor power	P_r [kW]	0.25	0.37	
Three-phase asynchronous motor (4-pole)	P_r [hp]	0.34	0.5	
8200 vector - type	EMC filter integrated	E82EV251K2C0xx	E82EV371K2C0xx	
	without EMC filter	E82EV251K2C2xx	E82EV371K2C2xx	
Mains voltage	U_{mains} [V]	1/N/PE 180 V AC-0%...264 V +0%; 45 Hz -0%...65 Hz +0%		
Alternative DC supply	U_{DC} [V]	not possible		
Data for operation at 1/N/PE 230 V AC				
Rated mains current	Without mains choke	I_{mains} [A]	3.4	5.0
	With mains choke	I_{mains} [A]	3.0	4.2
Output power U, V, W (at 8 kHz)	S_N [kVA]	0.68	1.0	
Output power $+U_G, -U_G$	P_{DC} [kW]	DC bus connection not possible		
Rated output current at a chopper frequency of	2 kHz	I_r [A] ⁵⁾	1.7	2.4
	4 kHz			
	8 kHz	I_r [A]	1.7	2.4
	16 kHz ⁴⁾	I_r [A]	1.1	1.6
Max. permissible output current for 60 s at a chopper frequency of ³⁾	2 kHz	I_{max} [A]	2.5	3.6
	4 kHz			
	8 kHz	I_{max} [A]	2.5	3.6
	16 kHz ⁴⁾	I_{max} [A]	1.7	2.3
Output voltage	Without mains choke	U_M [V]	3~ 0... U_{mains} [V] 650 Hz	
	With mains choke	U_M [V]	3~ 0... approx. 94% U_{mains} / 0...650 Hz	
Power loss (operation at I_r at 8 kHz)	P_{loss} [W]	30	40	
Mains choke required	Type	-	-	
Dimensions	HxWxD [mm]	120 x 60 x 140		
Weight	m [kg]	0.8	0.8	

Bold text = Data for operation at a chopper frequency of 8 kHz (Lenze setting)

³⁾ Currents for periodic load change cycle: 1 min overcurrent duration at I_{max} and 2 min base load duration at 75% I_r

⁴⁾ Operating frequency will be reduced to 4 kHz if ϑ_{max} reaches - 5°C

⁵⁾ Possible for some types under other operating conditions: Operation at increased rated output current with identical load change cycle.



Base controllers

Operation at rated power (normal operation)

Ratings at 230 V mains voltage

Typical motor power	P_r [kW]	0.55	0.75	1.5	2.2					
Three-phase asynchronous motor (4-pole)	P_r [hp]	0.75	1.0	2.0	3.0					
8200 vector - type	EMC filter integrated	E82EV551 K2C0xx	E82EV751 K2C0xx	E82EV152 K2C0xx	E82EV222 K2C0xx					
	without EMC filter	E82EV551 K2C2xx	E82EV751 K2C2xx	E82EV152 K2C2xx	E82EV222 K2C2xx					
Mains voltage	U_{mains} [V]	1/N/PE 180 V AC-0%...264 V+ 0%; 45 Hz - 0%...65 Hz + 0% 3/PE 100 V AC 0%...264 V + 0% ; 45 Hz - 0% ...65 Hz +0%								
Alternative DC supply	U_{DC} [V]	140 V DC 0%... 370 V +0%								
Data for operation at 1/N/PE (3/PE) 230 V AC or 325 V DC		1/N/PE	3/PE	1/N/PE	3/PE	1/N/PE	3/PE	1/N/PE ¹⁾	3/PE	
Rated mains current	Without mains choke	I_{mains} [A]	6.0	3.9	9.0	5.2	15.0	9.1	-	12.4
	With mains choke	I_{mains} [A]	5.6	2.7	7.5	3.6	12.5	6.3	18.0	9.0
Output power U, V, W (at 8 kHz)	S_N [kVA]	1.2		1.6		2.8		3.8		
Output power + U_G , - U_G ²⁾	P_{DC} [kW]	-	0.3	-	0.1	-	1.1	-	0.4	
Rated output current at a chopper frequency of	2 kHz	I_r [A] ⁵⁾	3.0		4.0		7.0		9.5	
	4 kHz		3.0		4.0		7.0		9.5	
	8 kHz	I_r [A]	2.0		2.6		4.6		6.2	
	16 kHz ⁴⁾	I_r [A]	2.9		3.9		6.9		9.3	
Max. permissible output current for 60 s at a chopper frequency of ³⁾	2 kHz	I_{max} [A]	4.5		6.0		10.5		14.2	
	4 kHz		4.5		6.0		10.5		14.2	
	8 kHz	I_{max} [A]	2.9		3.9		6.9		9.3	
	16 kHz ⁴⁾	I_{max} [A]	2.9		3.9		6.9		9.3	
Output voltage	Without mains choke	U_M [V]	3~ 0 ...U mains/0 ...650 Hz							
	With mains choke	U_M [V]	3~ 0... approx. 94% U_{mains} /0 ...650 Hz							
Power loss (operation at I_r at 8 kHz)	P_{loss} [W]	50		60		100		130		
Mains choke required	Type	-		-		-		ELN1-0250 H018	-	
Dimensions	HxWxD [mm]	180 x 60 x 140			240 x 60 x 140					
Weight	m [kg]	1.2			1.6					

Bold text = Data for operation at a chopper frequency of 8 kHz (Lenze setting)

¹⁾ Operation only permitted with a mains choke

²⁾ Power in addition to that which can be drawn from the DC bus in power-adaptive operation

³⁾ Currents for periodic load change cycle: 1 min overcurrent duration at I_{max} and 2 min base load duration at 75% I_r

⁴⁾ Chopper frequency will be reduced to 4 kHz if ϑ_{max} reaches - 5°C

⁵⁾ Possible for some types under other operating conditions: Operation at increased rated output current with identical load change cycle.



Base controllers

Operation at rated power (normal operation)

Ratings at 230 V mains voltage

Typical motor power	P_r [kW]	3.0	4.0	5.5	7.5	
Three-phase asynchronous motor (4-pole)	P_r [hp]	4.1	5.4	7.5	10.2	
8200 vector - type	EMC filter integrated	E82EV302 K2C0xx	E82EV402 K2C0xx	E82EV552 K2C0xx	E82EV752 K2C0xx ¹⁾	
	without EMC filter	E82EV302 K2C2xx	E82EV402 K2C2xx	E82EV552 K2C2xx	E82EV752 K2C2xx ¹⁾	
Mains voltage	U_{mains} [V]	3/PE 100 V AC -0%...264 V+0%; 45 Hz -0%...65 Hz+0%				
Alternative DC supply	U_{DC} [V]	140 V DC 0%... 370 V +0%				
Data for operation at 3/PE 230 V AC or 325 V DC						
Rated mains current	Without mains choke	I_{mains} [A]	15.6	21.3	29.3	-
	With mains choke	I_{mains} [A]	12.0	16.0	21.0	28.0
Output power U, V, W (at 8 kHz)	S_r [kVA]	4.8	6.6	9.0	11.4	
Output power + U_G , - U_G ²⁾	P_{DC} [kW]	0.9	0.8	1.1	0	
Rated output current at a chopper frequency of	2 kHz	I_r [A] ⁵⁾	12.0	19.8	22.5	28.6
	4 kHz					
	8 kHz	I_r [A]	12.0	16.5	22.5	28.6
	16 kHz ⁴⁾	I_r [A]	7.8	10.7	14.6	18.6
Max. permissible output current for 60 s at a chopper frequency of of ³⁾	2 kHz	I_{max} [A]	18.0	24.8	33.8	42.9
	4 kHz					
	8 kHz	I_{max} [A]	18.0	24.8	33.8	42.9
	16 kHz ⁴⁾	I_{max} [A]	11.7	16.1	21.9	27.9
Output voltage	Without mains choke	U_M [V]	3~ 0... U_{mains} [V] 650 Hz			
	With mains choke	U_M [V]	3~ 0...approx. 94% U_{mains} / 0...650 Hz			
Power loss (operation at I_r , 8 kHz)	P_{loss} [W]	150	190	250	320	
Mains choke required	Type	-	-	-	ELN3-0088H035	
Dimensions	HxWxD [mm]	240 x 100 x 140		240 x 125 x 140		
Weight	m [kg]	2.9		3.6		

Bold text = Data for operation at a chopper frequency of 8 kHz (Lenze setting)

¹⁾ Operation only permitted with a mains choke or mains filter

²⁾ Power in addition to that which can be drawn from the DC bus in power-adaptive operation

³⁾ Currents for periodic load change cycle: 1 min overcurrent duration at I_{max} and 2 min base load duration at 75% I_{rx}

⁴⁾ Chopper frequency will be reduced to 4 kHz if ϑ_{max} reaches -5°C

⁵⁾ Possible for some types under other operating conditions: Operation at increased rated output current with identical load change cycle.



Base controllers

Operation at rated power (normal operation)

Ratings at 400 V mains voltage

Typical motor power	P_r [kW]	0.55	0.75	1.5	2.2	
Three-phase asynchronous motor (4-pole)	P_r [hp]	0.75	1.0	2.0	3.0	
8200 vector - type	EMC filter integrated	E82EV551 K4C0xx ⁶⁾	E82EV751 K4C0xx ⁶⁾	E82EV152 K4C0xx ⁶⁾	E82EV222 K4C0xx ⁶⁾	
	without EMC filter	E82EV551 K4C2xx	E82EV751 K4C2xx	E82EV152 K4C2xx	E82EV222 K4C2xx	
Mains voltage	U_{mains} [V]	3/PE 320 V AC - 0%...550 V + 0%; 45 Hz - 0%...65 Hz + 0%				
Alternative DC supply	U_{DC} [V]	450 V DC 0%...775 V + 0%				
Data for operation at 3/PE 400 V AC or 565 V DC						
Rated mains current	Without mains choke	I_{mains} [A]	2.5	3.3	5.5	7.3
	With mains choke	I_{mains} [A]	2.0	2.3	3.9	5.1
Output power U, V, W (at 8 kHz)	S_r [kVA]	1.3	1.7	2.7	3.9	
Output power + U_G , - U_G ²⁾	P_{DC} [kW]	0.3	0.1	1.1	0.4	
Rated output current at a chopper frequency of	2 kHz	I_r [A] ⁵⁾	1.8	2.4	4.7	5.6
	4 kHz					
	8 kHz	I_r [A]	1.8	2.4	3.9	5.6
	16 kHz ⁴⁾	I_r [A]	1.2	1.6	2.5	3.6
Max. permissible output current for 60 s at a chopper frequency of of ³⁾	2 kHz	I_{max} [A]	2.7	3.6	5.9	8.4
	4 kHz					
	8 kHz	I_{max} [A]	2.7	3.6	5.9	8.4
	16 kHz ⁴⁾	I_{max} [A]	1.8	2.4	3.8	5.5
Output voltage	Without mains choke	U_M [V]	3~ 0... U_{mains} [V] 650 Hz			
	With mains choke	U_M [V]	3~ 0...approx. 94% U_{mains} / 0...650 Hz			
Power loss (operation at I_r at 8 kHz)	P_{loss} [W]	50	60	100	130	
Mains choke required	Type	-	-	-	E82ZZL22234B	
Dimensions	HxWxD [mm]	180 x 60 x 140		240 x 60 x 140		
Weight	m [kg]	1.2		1.6		

Bold text = Data for operation at a chopper frequency of 8 kHz (Lenze setting)

²⁾ Power in addition to that which can be drawn from the DC bus in power-adaptive operation

³⁾ Currents for periodic load change cycle: 1 min overcurrent duration at I_{max} and 2 min base load duration at 75% I_r

⁴⁾ Chopper frequency will be reduced to 4 kHz if ϑ_{max} reaches -5°C

⁵⁾ Possible for some types under other operating conditions: Operation at increased rated output current with identical load change cycle.

⁶⁾ For mains voltages from 484 V (-0%) ... 550 V (+0%): Operation is only permitted with brake resistor.



Base controllers

Operation at rated power (normal operation)

Ratings at 400 V mains voltage

Typical motor power	P_r [kW]	3.0	4.0	5.5	7.5	11	
Three-phase asynchronous motor (4-pole)	P_r [hp]	4.1	5.4	7.5	10.2	15	
8200 vector - type	EMC filter integrated	E82EV302 K4C0xx	E82EV402 K4C0xx	E82EV552 K4C0xx	E82EV752 K4C0xx	E82EV113 K4C0xx ¹⁾	
	without EMC filter	E82EV302 K4C2xx	E82EV402 K4C2xx	E82EV552 K4C2xx	E82EV752 K4C2xx	E82EV113 K4C2xx ¹⁾	
Mains voltage	U_{mains} [V]	3/PE 320 V AC 0%... 550 V +0%; 45 Hz 0%... 65 Hz +0%					
Alternative DC supply	U_{DC} [V]	450 V DC 0%... 775 V +0%					
Data for operation at 3/PE 400 V AC or 565 V DC							
Rated mains current	Without mains choke	I_{mains} [A]	9.0	12.3	16.8	21.5	-
	With mains choke	I_{mains} [A]	7.0	8.8	12.0	15.0	21.0
Output power U, V, W (at 8 kHz)	S_r [kVA]	5.1	6.6	9.0	11.4	16.3	
Output power +U _G , -U _G ²⁾	P_{DC} [kW]	1.7	0.8	1.1	1.5	0	
Rated output current at a chopper frequency of	2 kHz	I_r [A] ⁵⁾	7.3	9.5	13.0	16.5	23.5
	4 kHz		7.3	9.5	13.0	16.5	23.5
	8 kHz	I_r [A]	7.3	9.5	13.0	16.5	23.5
	16 kHz ⁴⁾	I_r [A]	4.7	6.1	8.4	10.7	13.0
Max. permissible output current for 60 s at a chopper frequency of ³⁾	2 kHz	I_{max} [A]	11.0	14.2	19.5	24.8	35.3
	4 kHz		11.0	14.2	19.5	24.8	35.3
	8 kHz	I_{max} [A]	11.0	14.2	19.5	24.8	35.3
	16 kHz ⁴⁾	I_{max} [A]	7.0	9.1	12.6	16.0	19.5
Output voltage	Without mains choke	U_M [V]	3~ 0... U_{mains} [V] 650 Hz				
	With mains choke	U_M [V]	3~ 0...approx. 94% U_{mains} / 0...650 Hz				
Power loss (operation at I_r at 8 kHz)	P_{loss} [W]	145	180	230	300	410	
Mains choke required	Type	-	-	-	-	ELN3-150H024	
Dimensions	HxWxD [mm]	240 x 100 x 140			240 x 125 x 140		
Weight	m [kg]	2.9			3.6		

Bold text = Data for operation at a chopper frequency of 8 kHz (Lenze setting)

¹⁾ Operation only permitted with a mains choke or mains filter

²⁾ Power in addition to that which can be drawn from the DC bus in power-adaptive operation

³⁾ Currents for periodic load change cycle: 1 min overcurrent duration at I_{max} and 2 min base load duration at 75% I_r

⁴⁾ Chopper frequency will be reduced to 4 kHz if ϑ_{max} reaches -5°C

⁵⁾ Possible for some types under other operating conditions: Operation at increased rated output current with identical load change cycle.



Base controllers

Operation at rated power (normal operation)

Ratings at 400 V mains voltage

Typical motor power	P_r [kW]	15	22	30	
Three-phase asynchronous motor (4-pole)	P_r [hp]	20	30	40	
8200 vector - type	Mains filter integrated	E82EV153K4B3xx ⁶⁾	E82EV223K4B3xx ⁶⁾	E82EV303K4B3xx ⁶⁾	
	without EMC filter	E82EV153K4B2xx	E82EV223K4B2xx ¹⁾	E82EV303K4B2xx ¹⁾	
Mains voltage	U_{mains} [V]	3/PE 320 V AC - 0%...550 V +0%; 45 Hz - 0%...65 Hz +0%			
Alternative DC supply	U_{DC} [V]	450 V DC 0%...775 V +0%			
Data for operation at 3/PE 400 V AC or 565 V DC					
Rated mains current	Without mains choke/mains filter	I_{mains} [A]	43.5	-	-
	With mains choke/mains filter	I_{mains} [A]	29.0	42.0	55.0
Output power U, V, W (at 8 kHz)	S_r [kVA]	22.2	32.6	41.6	
Output power $+U_G, -U_G$ ²⁾	P_{DC} [kW]	10.2	4.0	0	
Rated output current at a chopper frequency of	1 kHz	I_r [A] ⁵⁾	32	47	59
	2 kHz				
	4 kHz				
	8 kHz	I_r [A]	32	47	59
	16 kHz ⁴⁾	I_r [A]	24	35	44
Max. permissible output current for 60 s at a chopper frequency of ³⁾	1 kHz	I_{max} [A]	48	70.5	89
	2 kHz				
	4 kHz				
	8 kHz	I_{max} [A]	48	70.5	89
	16 kHz ⁴⁾	I_{max} [A]	36	53	66
Output voltage	Without mains choke/mains filter	U_M [V]	3~ 0... U_{mains} [V] 650 Hz		
	With mains choke/mains filter	U_M [V]	3~ 0...approx. 94% U_{mains} / 0 ...650 Hz		
Power loss (operation at I_r at 8 kHz)	P_{loss} [W]	430	640	810	
Mains choke required	Type	-	ELN3-0075H045	ELN3-0055H055	
Dimensions	With mains filter	HxWxD [mm]	250 x 350 x 340		
	Without mains filter	HxWxD [mm]	250 x 350 x 250		
Weight	With mains filter	m [kg]		34	
	Without mains filter			15	

Bold text = Data for operation at a chopper frequency of 8 kHz (Lenze setting)

¹⁾ Operation only permitted with a mains choke or mains filter

²⁾ Power in addition to that which can be drawn from the DC bus in power-adaptive operation

³⁾ Currents for periodic load change cycle: 1 min overcurrent duration at I_{max} and 2 min base load duration at 75% I_r

⁴⁾ Chopper frequency will be reduced to 4 kHz if ϑ_{max} reaches -5°C

⁵⁾ Possible for some types under other operating conditions: Operation at increased rated output current with identical load change cycle.

⁶⁾ Delivery will be effected upon request (in preparation)



Base controllers

Operation at rated power (normal operation)

Ratings at 400 V mains voltage

Typical motor power	P_r [kW]	45	55	75	90	
Three-phase asynchronous motor (4-pole)	P_r [hp]	60	75	100	120	
8200 vector - type	Mains filter integrated	E82EV453 K4B3xx ⁶⁾	E82EV553 K4B3xx ⁶⁾	E82EV753 K4B3xx ⁶⁾	E82EV903 K4B3xx ⁶⁾	
	without EMC filter	E82EV453 K4B2xx ¹⁾	E82EV553 K4B2xx ¹⁾	E82EV753 K4B2xx ¹⁾	E82EV903 K4B2xx ¹⁾	
Mains voltage	U_{mains} [V]	3/PE 320 V AC 0%... 550 V +0%; 45 Hz 0%... 65 Hz +0%				
Alternative DC supply	U_{DC} [V]	450 V DC 0%... 775 V +0%				
Data for operation at 3/PE 400 V AC or 565 V DC						
Rated mains current	Without mains choke/mains filter	I_{mains} [A]	-	-	-	-
	With mains choke/mains filter	I_{mains} [A]	80.0	100	135	165
Output power U, V, W (at 8 kHz)	S_r [kVA]	61.7	76.2	103.9	124.7	
Output power + U_G , - U_G ²⁾	P_{DC} [kW]	5.1	0	28.1	40.8	
Rated output current at a chopper frequency of	1 kHz	I_r [A] ⁵⁾	89	110	150	180
	2 kHz					
	4 kHz					
	8 kHz	I_r [A]	89	110	150	171
	16 kHz ⁴⁾	I_r [A]	54	77	105	108
Max. permissible output current for 60 s at a chopper frequency of ³⁾	1 kHz	I_{max} [A]	134	165	225	270
	2 kHz					
	4 kHz					
	8 kHz	I_{max} [A]	134	165	225	221
	16 kHz ⁴⁾	I_{max} [A]	81	100	136	140
Output voltage	Without mains choke/mains filter	U_M [V]	3~ 0... U_{mains} [V] 650 Hz			
	With mains choke/mains filter	U_M [V]	3~ 0...approx. 94% U_{mains} / 0 ...650 Hz			
Power loss (operation at I_r at 8 kHz)	P_{loss} [W]	1100	1470	1960	2400	
Mains choke required	Type	ELN3-0038H085	ELN3-0027H105	ELN3-0022H130	ELN3-0017H170	
Dimensions	With mains filter	HxWxD [mm]	340 x 510 x 375	340 x 591 x 375	450 x 680 x 375	
	Without mains filter	HxWxD [mm]	340 x 510 x 285	340 x 591 x 285	450 x 680 x 285	
Weight	With mains filter	m [kg]	60	66	112	
	Without mains filter		34	37	59	

Bold text = Data for operation at a chopper frequency of 8 kHz (Lenze setting)

¹⁾ Operation only permitted with a mains choke or mains filter

²⁾ Power in addition to that which can be drawn from the DC bus in power-adaptive operation

³⁾ Currents for periodic load change cycle: 1 min overcurrent duration at I_{max} and 2 min base load duration at 75% I_r

⁴⁾ Chopper frequency will be reduced to 4 kHz if ϑ_{max} reaches - 5°C

⁵⁾ Possible for some types under other operating conditions: Operation at increased rated output current with identical load change cycle.

⁶⁾ Delivery will be effected upon request (in preparation)

Base controllers

Operation at rated power (normal operation)



Base controllers

Operation at rated power (normal operation)

Ratings at 500 V mains voltage

Typical motor power	P_r [kW]	0.55	0.75	1.5	2.2	
Three-phase asynchronous motor (4-pole)	P_r [hp]	0.75	1.0	2.0	3.0	
8200 vector - type	EMC filter integrated	E82EV551 K4C0xx ¹⁾	E82EV751 K4C0xx ¹⁾	E82EV152 K4C0xx ¹⁾	E82EV222 K4C0xx ¹⁾	
	without EMC filter	E82EV551 K4C2xx	E82EV751 K4C2xx	E82EV152 K4C2xx	E82EV222 K4C2xx	
Mains voltage	U_{mains} [V]	3/PE 320 V AC 0%...550 V +0%; 45 Hz 0%...65 Hz +0%				
Alternative DC supply	U_{DC} [V]	450 V DC 0%...775 V +0%				
Data for operation at 3/PE 500 V AC or 710 V DC						
Rated mains current	Without mains choke	I_{mains} [A]	2.0	2.6	4.4	5.8
	With mains choke	I_{mains} [A]	1.4	1.8	3.1	4.1
Output power U, V, W (at 8 kHz)	S_r [kVA]	1.3	1.7	2.7	3.9	
Output power + U_G , - U_G ²⁾	P_{DC} [kW]	0.3	0.1	1.1	0.4	
Rated output current at a chopper frequency of	2 kHz	I_r [A]	1.4	1.9	3.1	4.5
	4 kHz					
	8 kHz	I_r [A]	1.4	1.9	3.1	4.5
	16 kHz ⁴⁾	I_r [A]	0.9 ⁵⁾	1.2 ⁵⁾	2.0	2.9
Max. permissible output current for 60 s at a chopper frequency of ³⁾	2 kHz	I_{max} [A]	2.7	3.6	5.9	8.4
	4 kHz					
	8 kHz	I_{max} [A]	2.7	3.6	5.9	8.4
	16 kHz ⁴⁾	I_{max} [A]	1.35 ⁵⁾	1.85 ⁵⁾	3.0	4.4
Output voltage	Without mains choke	U_M [V]	3~ 0... U_{mains} [V] 650 Hz			
	With mains choke	U_M [V]	3~ 0...approx. 94% U_{mains} / 0 ...650 Hz			
Power loss (operation at I_r at 8 kHz)	P_{loss} [W]	50	60	100	130	
Brake resistor required ¹⁾	Type	ERBM470R100W		ERBM370 R150W	ERBM240 R200W	
Dimensions	HxWxD [mm]	180 x 60 x 140		240 x 60 x 140		
Weight	m [kg]	1.2		1.6		

Bold text = Data for operation at a chopper frequency of 8 kHz (Lenze setting)

1) For mains voltages 484 V (-0%)... 550 V (+0%): Operation is only permitted with brake resistor

2) Power in addition to that which can be drawn from the DC bus in power-adaptive operation

3) Currents for periodic load change cycle: 1 min overcurrent duration at I_{max} and 2 min base load duration at 75% I_r

4) Chopper frequency will be reduced to 4 kHz if ϑ_{max} reaches - 5°C

5) Max. motor cable length 10 m!



Base controllers

Operation at rated power (normal operation)

Ratings at 500 V mains voltage

Typical motor power	P_r [kW]	3.0	4.0	5.5	7.5	11					
Three-phase asynchronous motor (4-pole)	P_r [hp]	4.1	5.4	7.5	10.2	15					
8200 vector - type	EMC filter integrated	E82EV302 K4C0xx	E82EV402 K4C0xx	E82EV552 K4C0xx	E82EV752 K4C0xx	E82EV113 K4C0xx¹⁾					
	without EMC filter	E82EV302 K4C2xx	E82EV402 K4C2xx	E82EV552 K4C2xx	E82EV752 K4C2xx	E82EV113 K4C2xx¹⁾					
Mains voltage	U_{mains} [V]	3/PE 320 V AC 0%...550 V +0%; 45 Hz - 0%...65 Hz +0%									
Alternative DC supply	U_{DC} [V]	450 V DC 0%...775 V +0%									
Data for operation at 3/PE 500 V AC or 710 V DC											
Rated mains current											
Without mains choke	I_{mains} [A]	7.2	9.8	13.4	17.2	-					
With mains choke	I_{mains} [A]	5.6	7.0	9.6	12.0	16.8					
Output power U, V, W (at 8 kHz)	S_r [kVA]	5.1	6.6	9.0	11.4	16.3					
Output power + U_G , - U_G ²⁾	P_{DC} [kW]	1.7	0.8	1.1	1.5	0					
Rated output current at a chopper frequency of	2 kHz	I_r [A]	5.8	7.6	10.4	13.2					
	4 kHz										
	8 kHz						5.8	7.6	10.4	13.2	18.8
	16 kHz ⁴⁾						3.8	4.9	6.8	8.6	12.2
Max. permissible output current for 60 s at a chopper frequency of ³⁾	2 kHz	I_{max} [A]	11.0	14.2	19.5	24.8					
	4 kHz										
	8 kHz						11.0	14.2	19.5	24.8	35.3
	16 kHz ⁴⁾						5.7	7.9	10.0	12.9	18.3
Output voltage	Without mains chok/ With mains choke	U_M [V]	3~ 0... U_{mains} [V] 650 Hz								
		U_M [V]	3~ 0...approx. 94% $U_{mains}/0$...650 Hz								
Power loss (operation at I_r at 8 kHz)	P_{loss} [W]	145	180	230	300	410					
Mains choke required	Type	-	-	-	-	ELN3-150 H024					
Dimensions	HxWxD [mm]	240 x 100 x 140			240 x 125 x 140						
Weight	m [kg]	2.9			3.6						

Bold text = Data for operation at a chopper frequency of 8 kHz (Lenze setting)

- 1) Operation only permitted with a mains choke
- 2) Power in addition to that which can be drawn from the DC bus in power-adaptive operation
- 3) Currents for periodic load change cycle: 1 min overcurrent duration at I_{max} and 2 min base load duration at 75% I_r
- 4) Chopper frequency will be reduced to 4 kHz if ϑ_{max} reaches - 5°C



Base controllers

Operation at rated power (normal operation)

Ratings at 500 V mains voltage

Typical motor power	P_r [kW]	18.5	30	37
Three-phase asynchronous motor (4-pole)	P_r [hp]	25	40	49.5
8200 vector - type	EMC filter integrated	E82EV153K4B3xx ⁵⁾	E82EV223K4B3xx ⁵⁾	E82EV303K4B3xx ⁵⁾
	without EMC filter	E82EV153K4B2xx	E82EV223K4B2xx ¹⁾	E82EV303K4B2xx ¹⁾
Mains voltage	U_{mains} [V]	3/PE 320 V AC 0%... 550 V +0%; 45 Hz 0%...65 Hz +0%		
Alternative DC supply	U_{DC} [V]	450 V DC 0%...775 V +0%		
Data for operation at 3/PE 500 V AC or 710 V DC				
Rated mains current				
Without mains choke/mains filter	I_{mains} [A]	43.5	-	-
With mains choke/mains filter	I_{mains} [A]	29.0	42.0	55.0
Output power U, V, W (at 8 kHz)	S_r [kVA]	26.6	39.1	49.9
Output power + U_G , - U_G ²⁾	P_{DC} [kW]	11.8	4.6	0
Rated output current at a chopper frequency of	1 kHz	I_r [A]	32	47
	2 kHz			
	4 kHz	I_r [A]	32	47
	8 kHz			
	16 kHz ⁴⁾			
Max. permissible output current for 60 s at a chopper frequency of ³⁾	1 kHz	I_{max} [A]	48	70.5
	2 kHz			
	4 kHz	I_{max} [A]	48	70.5
	8 kHz			
	16 kHz ⁴⁾			
Output voltage	Without mains choke/mains filter	U_M [V]	3~ 0... U_{mains} [V] 650 Hz	
	With mains choke/mains filter	U_M [V]	3~ 0...approx. 94% U_{mains} / 0 ...650 Hz	
Power loss (operation at I_r at 8 kHz)	P_{loss} [W]	430	640	810
Mains choke required	Type	-	ELN3-0075H045	ELN3-0055H055
Dimensions	With mains filter	HxWxD [mm]	250 x 350 x 340	
	Without mains filter	HxWxD [mm]	250 x 350 x 250	
Weight	With mains filter	m [kg]	34	
	Without mains filter		15	

Bold text = Data for operation at a chopper frequency of 8 kHz (Lenze setting)

¹⁾ Operation only permitted with a mains choke or mains filter

²⁾ Power in addition to that which can be drawn from the DC bus in power-adaptive operation

³⁾ Currents for periodic load change cycle: 1 min overcurrent duration at I_{max} and 2 min base load duration at 75% I_r

⁴⁾ Chopper frequency will be reduced to 4 kHz if ϑ_{max} reaches - 5°C

⁵⁾ Delivery will be effected upon request (in preparation)



Base controllers

Operation at rated power (normal operation)

Ratings at 500 V mains voltage

Typical motor power	P_r [kW]	55	75	90	110	
Three-phase asynchronous motor (4-pole)	P_r [hp]	74	100	120	148	
8200 vector - type	EMC filter integrated	E82EV453 K4B3xx ⁵⁾	E82EV553 K4B3xx ⁵⁾	E82EV753 K4B3xx ⁵⁾	E82EV903 K4B3xx ⁵⁾	
	without EMC filter	E82EV453 K4B2xx ¹⁾	E82EV553 K4B2xx ¹⁾	E82EV753 K4B2xx ¹⁾	E82EV903 K4B2xx ¹⁾	
Mains voltage	U_{mains} [V]	3/PE 320 V AC - 0%...550 V +0%; 45 Hz - 0%...65 Hz +0%				
Alternative DC supply	U_{DC} [V]	450 V DC 0%... 775 V +0%				
Data for operation at 3/PE 500 V AC or 710 V DC						
Rated mains current	Without mains choke/mains filter	I_{mains} [A]	-	-	-	-
	With mains choke/mains filter	I_{mains} [A]	80.0	100	135	165
Output power U, V, W (at 8 kHz)	S_r [kVA]	73.9	91.4	124	149	
Output power + U_G , - U_G ²⁾	P_{DC} [kW]	5.9	0	32.4	47.1	
Rated output current at a chopper frequency of	1 kHz	I_r [A] ⁵⁾	84	105	142	171
	2 kHz					
	4 kHz					
	8 kHz	I_r [A]	84	105	142	162
	16 kHz ⁴⁾	I_r [A]	58	72	98	99
Max. permissible output current for 60 s at a chopper frequency of ³⁾	1 kHz	I_{max} [A]	126	157	213	256
	2 kHz					
	4 kHz					
	8 kHz	I_{max} [A]	126	157	213	211
	16 kHz ⁴⁾	I_{max} [A]	75	94	128	130
Output voltage	Without mains choke/mains filter	U_M [V]	3~ 0... U_{mains} [V] 650 Hz			
	With mains choke/mains filter	U_M [V]	3~ 0...approx. 94% U_{mains} / 0 ...650 Hz			
Power loss (operation at I_r at 8 kHz)	P_{loss} [W]	1100	1470	1960	2400	
Mains choke required	Type	ELN3-0038H085	ELN3-0027H105	ELN3-0022H130	ELN3-0017H170	
Dimensions	With mains filter	HxWxD [mm]	340 x 510 x 375	340 x 591 x 375	450 x 680 x 375	
	Without mains filter	HxWxD [mm]	340 x 510 x 285	340 x 591 x 285	450 x 680 x 285	
Weight	With mains filter	m [kg]	60	66	112	
	Without mains filter		34	37	59	

Bold text = Data for operation at a chopper frequency of 8 kHz (Lenze setting)

¹⁾ Operation only permitted with a mains choke or mains filter

²⁾ Power in addition to that which can be drawn from the DC bus in power-adaptive operation

³⁾ Currents for periodic load change cycle: 1 min overcurrent duration at I_{max} and 2 min base load duration at 75% I_r

⁴⁾ Chopper frequency will be reduced to 4 kHz if ϑ_{max} reaches - 5°C

⁵⁾ Delivery will be effected upon request (in preparation)

Base controllers

Operation at rated power (normal operation)

2



Base controllers

Operation at increased rated power

Ratings at 230 V mains voltage

Typical motor power	P_r [kW]	0.37	0.75	1.1	2.2			
Three-phase asynchronous motor (4-pole)	P_r [hp]	0.5	1.0	1.5	3.0			
8200 vector - type	EMC filter integrated	E82EV251 K2C0xx	E82EV551 K2C0xx ¹⁾	E82EV751 K2C0xx ¹⁾	E82EV152 K2C0xx			
	without EMC filter	E82EV251 K2C2xx	E82EV551 K2C2xx ¹⁾	E82EV751 K2C2xx ¹⁾	E82EV152 K2C2xx			
Mains voltage	U_{mains} [V]	1/N/PE 180 V AC - 0%...264 V + 0%; 45 Hz - 0%... 65 Hz + 0% 3/PE 100 V AC - 0%... 264 V + 0%; 45 Hz - 0%... 65 Hz + 0%						
Alternative DC supply	U_{DC} [V]	not possible	140 V DC - 0%... 370 V + 0%					
Data for operation at 1/N/PE (3PE) 230 V AC or 325 V DC		1/N/PE	1/N/PE	3/PE	1/N/PE	3/PE	1/N/PE	3/PE
Rated mains current								
Without mains choke	I_{mains} [A]	4.1	-	-	-	-	18.0	10.4
With mains choke	I_{mains} [A]	3.6	6.7	3.3	9.0	4.4	15.0	7.6
Output power U, V, W (at 2/4 kHz)	S_r [kVA]	0.8	1.4	1.9	3.3			
Output power + U_G , - U_G ²⁾	P_{DC} [kW]	DC bus connection not possible	0.1	0	0.4			
Rated output current at a chopper frequency of	I_r [A]	2 kHz	2.0	3.6	4.8	8.4		
		4 kHz						
Max. permissible output current for 60 s at a chopper frequency of ³⁾	I_{max} [A]	2 kHz	2.5	4.5	6.0	10.5		
		4 kHz						
Output voltage								
Without mains choke	U_M [V]	3~ 0... U_{mains} [V] 650 Hz						
With mains choke	U_M [V]	3~ 0...approx. 94% U_{mains} / 0...650 Hz						
Power loss (operation at I_r , 2/4 kHz)	P_{loss} [W]	30	50	60	100			
Mains choke required	Type	-	ELN1-0500H005	ELN1-0500 H009	E82ZL751 32B	-		
Dimensions	HxWxD [mm]	120 x 60 x 140	180 x 60 x 140		240 x 60 x 140			
Weight	m [kg]	0.8	1.2		1.6			

¹⁾ Operation only permitted with a mains choke

²⁾ Power in addition to that which can be drawn from the DC bus in power-adaptive operation

³⁾ Currents for periodic load change cycle: 1 min overcurrent duration at I_{max} and 2 min base load duration at 75% I_r



Ratings at 230 V mains voltage

Typical motor power	P_r [kW]	4.0	7.5
Three-phase asynchronous motor (4-pole)	P_r [hp]	5.4	10.2
8200 vector - type	EMC filter integrated	E82EV302K2C0xx	E82EV552K2C0xx ¹⁾
	without EMC filter	E82EV302K2C2xx	E82EV552K2C2xx ¹⁾
Mains voltage	U_{mains} [V]	3/PE 100 V AC 0%... 264 V +0%; 45 Hz 0%...65 Hz +0%	
Alternative DC supply	U_{DC} [V]	140 V DC 0%... 370 V +0%	
Data for operation at 3/PE 230 V AC or 325 V DC			
Rated mains current	Without mains choke	I_{mains} [A]	18.7
	With mains choke	I_{mains} [A]	14.4
Output power U, V, W (at 2/4 kHz)	S_r [kVA]	5.7	10.8
Output power $+U_G, -U_G$ ²⁾	P_{DC} [kW]	0	
Rated output current at a chopper frequency of	2 kHz	I_r [A]	14.4
	4 kHz		
Max. permissible output current for 60 s at a chopper frequency of ³⁾	2 kHz	I_{max} [A]	18.0
	4 kHz		
Output voltage	Without mains choke	U_M [V]	3~ 0... U_{mains} [V] 650 Hz
	With mains choke	U_M [V]	3~ 0...approx. 94% U_{mains} / 0...650 Hz
Power loss (operation at I_r , 2/4 kHz)	P_{loss} [W]	150	250
Mains choke required	Type	-	ELN3-088H035
Dimensions	HxWxD [mm]	240 x 100 x 140	240 x 125 x 140
Weight	m [kg]	2.9	3.6

¹⁾ Operation only permitted with mains choke

²⁾ Power in addition to that which can be drawn from the DC bus in power-adaptive operation

³⁾ Currents for periodic load change cycle: 1 min overcurrent duration at I_{max} and 2 min base load duration at 75% I_r



Base controllers

Operation at increased rated power

Ratings at 400 V mains voltage

Maximum motor power	P_r [kW]	0.75	1.1	3.0
Three-phase asynchronous motor (4-pole)	P_r [hp]	1.0	1.5	4.0
8200 vector - type	EMC filter integrated	E82EV551K4C0xx	E82EV751K4C0xx ¹⁾	E82EV222K4C0xx ¹⁾
	without EMC filter	E82EV551K4C2xx	E82EV751K4C2xx ¹⁾	E82EV222K4C2xx ¹⁾
Mains voltage	U_{mains} [V]	3/PE 320 V AC 0%... 440 V +0%; 45 Hz 0%... 65 Hz +0%		
Alternative DC supply	U_{DC} [V]	450 V DC 0%... 625 V +0%		
Data for operation at 3/PE 400 V AC or 565 V DC				
Rated mains current				
Without mains choke	I_{mains} [A]	2.9	-	-
With mains choke	I_{mains} [A]	2.4	2.8	6.1
Output power U, V, W (at 2/4 kHz)	S_N [kVA]	1.5	2.0	4.6
Output power + U_G , - U_G ²⁾	P_{DC} [kW]	0.1	0	0
Rated output current at a chopper frequency of	I_r [A]	2 kHz	2.2	2.9
		4 kHz		
Max. permissible output current for 60 s at a chopper frequency of ³⁾	I_{max} [A]	2 kHz	2.7	3.6
		4 kHz		
Output voltage				
Without mains choke	U_M [V]	3~ 0... U_{mains} [V] 650 Hz		
With mains choke	U_M [V]	3~ 0...approx. 94% U_{mains} / 0...650 Hz		
Power loss (operation at I_r , 2/4 kHz)	P_{loss} [W]	50	60	130
Mains choke required	Type	-	EZN3A1500H003	E82ZL22234B
Dimensions	HxWxD [mm]	1180 x 60 x 140		240 x 60 x 140
Weight	m [kg]	1.2		1.6

¹⁾ Operation only permitted with a mains choke

²⁾ Power in addition to that which can be drawn from the DC bus in power-adaptive operation

³⁾ Currents for periodic load change cycle: 1 min overcurrent duration at I_{max} and 2 min base load duration at 75% I_r



Ratings at 400 V mains voltage

Maximum motor power		P_r [kW]	4.0	5.5	11
Three-phase asynchronous motor (4-pole)		P_r [hp]	5.4	7.5	15
8200 vector - type	EMC filter integrated		E82EV302K4C0xx	E82EV402K4C0xx ¹⁾	E82EV752K4C0xx ¹⁾
	without EMC filter		E82EV302K4C2xx	E82EV402K4C2xx ¹⁾	E82EV752K4C2xx ¹⁾
Mains voltage		U_{mains} [V]	3/PE 320 V AC - 0%...440 V +0%; 45 Hz - 0%...65 Hz +0%		
Alternative DC supply		U_{DC} [V]	450 V DC 0%...625 V +0%		
Data for operation at 3/PE 400 V AC or 565 V DC					
Rated mains current					
Without mains choke		I_{mains} [A]	10.8	-	-
With mains choke		I_{mains} [A]	8.4	10.6	18.0
Output power U, V, W (at 2/4 kHz)		S_N [kVA]	6.0	7.9	13.7
Output power + U_G , - U_G ²⁾		P_{DC} [kW]	0	0	
Rated output current at a chopper frequency of	2 kHz	I_r [A]	8.7	11.4	19.8
	4 kHz				
Max. permissible output current for 60 s at a chopper frequency of ³⁾	2 kHz	I_{max} [A]	11.0	14.2	24.8
	4 kHz				
Output voltage					
Without mains choke		U_M [V]	3~ 0... U_{mains} [V] 650 Hz		
With mains choke		U_M [V]	3~ 0...approx. 94% U_{mains} / 0...650 Hz		
Power loss (operation at I_r , 2/4 kHz)		P_{loss} [W]	145	180	300
Mains choke required		Type	-	EZN3A0300H013	ELN3-0150H024
Dimensions		HxWxD [mm]	240 x 100 140		240 x 125 x 140
Weight		m [kg]	2.9		3.6

¹⁾ Operation only permitted with a mains choke

²⁾ Power in addition to that which can be drawn from the DC bus in power-adaptive operation

³⁾ Currents for periodic load change cycle: 1 min overcurrent duration at I_{max} and 2 min base load duration at 75% I_r



Base controllers

Operation at increased rated power

Ratings at 400 V mains voltage

Maximum motor power	P_r [kW]	22	30	37
Three-phase asynchronous motor (4-pole)	P_r [hp]	30	40	50
8200 vector - type	with mains filter	E82EV153K4B3xx ⁵⁾	E82EV223K4B3xx ⁵⁾	-
	without mains filter	E82EV153K4B2xx ¹⁾	E82EV223K4B2xx ¹⁾	E82EV303K4B2xx ¹⁾⁴⁾
Mains voltage	U_{mains} [V]	3/PE 320 V AC 0%...440 V +0%; 45 Hz 0%...65 Hz +0%		
Alternative DC supply	U_{DC} [V]	450 V DC 0%...625 V +0%		
Data for operation at 3/PE 400 V AC or 565 V DC				
Rated mains current	Without mains choke/mains filter	I_{mains} [A]	-	-
	With mains choke/mains filter	I_{mains} [A]	39.0	50.0
Output power U, V, W (at 2/4 kHz)	S_N [kVA]	29.8	39.5	46.4
Output power + U_G , - U_G ²⁾	P_{DC} [kW]	10.2	4.0	0
Rated output current at a chopper frequency of	1 kHz	I_r [A]	43	56
	2 kHz			
	4 kHz			
Max. permissible output current for 60 s at a chopper frequency of ³⁾	1 kHz	I_{max} [A]	48	70.5
	2 kHz			
	4 kHz			
Output voltage	Without mains choke/mains filter	U_M [V]	3~ 0... U_{mains} [V] 650 Hz	
	With mains choke/mains filter	U_M [V]	3~ 0...approx. 94% U_{mains} / 0...650 Hz	
Power loss (operation at I_r , 2/4 kHz)	P_{loss} [W]	430	640	810
Mains choke required	Type	ELN3-0075H045	ELN3-0055H055	ELN3-0055H055
Dimensions	With mains filter	HxWxD [mm]	250 x 350 x 340	
	Without mains filter	HxWxD [mm]	250 x 350 x 250	
Weight	With mains filter	m [kg]	34	
	Without mains filter		15	

- 1) Operation only permitted with a mains choke or mains filter
 2) Power in addition to that which can be drawn from the DC bus in power-adaptive operation
 3) Currents for periodic load change cycle: 1 min overcurrent duration at I_{max} and 2 min base load duration at 75% I_r
 4) Max. permissible ambient temperature during operation +35°C
 5) Delivery will be effected upon request (in preparation)



Ratings at 400 V mains voltage

Maximum motor power	P_r [kW]	55	75	90	110	
Three-phase asynchronous motor (4-pole)	P_r [hp]	75	100	120	148	
8200 vector - type	with mains filter	-	E82EV553 K4B3xx ^{4) 6)}	-	-	
	without mains filter	E82EV453 K4B2xx ¹⁾	E82EV553 K4B2xx ^{1) 4)}	E82EV753 K4B2xx ¹⁾	E82EV903 K4B2xx ^{1) 4)}	
Mains voltage	U_{mains} [V]	3/PE 320 V AC - 0%...440 V +0%; 45 Hz 0%...65 Hz +0%				
Alternative DC supply	U_{DC} [V]	450 V DC 0%... 625 V +0%				
Data for operation at 3/PE 400 V AC or 565 V DC						
Rated mains current	Without mains choke/mains filter	I_{mains} [A]	-	-	-	-
	With mains choke/mains filter	I_{mains} [A]	97.0	119	144	185
Output power U, V, W (at 2/4 kHz)	S_N [kVA]	74.8	91.5	110	142	
Output power $+U_G$, $-U_G$ ²⁾	P_{DC} [kW]	5.1	0	28.1	40.8	
Rated output current at a chopper frequency of	1 kHz	I_r [A] ⁵⁾	100	135	159	205
	2 kHz					
	4 kHz					
Max. permissible output current for 60 s at a chopper frequency of ³⁾	1 kHz	I_{max} [A]	134	165	225	270
	2 kHz					
	4 kHz					
Output voltage	Without mains choke/mains filter	U_M [V]	3~ 0... U_{mains} [V] 650 Hz			
	With mains choke/mains filter	U_M [V]	3~ 0...approx. 94% U_{mains} / 0...650 Hz			
Power loss (operation at I_r , 2/4 kHz)	P_{loss} [W]	1100	1470	1960	2400	
Mains choke required	Type	ELN3-0027 H105	ELN3-0022 H130	ELN3-0017 H170	ELN3-0014 H200	
Dimensions With mains filter	HxWxD [mm]	340 x 510 x 375	340 x 591 x 375	450 x 680 x 375		
	Without mains filter	HxWxD [mm]	340 x 510 x 285	340 x 591 x 285	450 x 680 x 285	
Weight	With mains filter	m [kg]	60	66	112	
	Without mains filter		34	37	59	

1) Operation only permitted with a mains choke or mains filter

2) Power in addition to that which can be drawn from the DC bus in power-adaptive operation

3) Currents for periodic load change cycle: 1 min overcurrent duration at I_{max} and 2 min base load duration at 75% I_r

4) Max. permissible ambient temperature during operation +35°C

5) Only operate with automatic chopper frequency reduction (C144 = 1). Make sure that the specified currents are not exceeded.

6) Delivery will be effected upon request (in preparation)



General information

- 8200 vector frequency inverters must only be used as built-in units
- If the exhaust air contains pollutants (dust, lint, grease, aggressive gases) then appropriate counter-measures must be in place (e.g. installation of filters, regular cleaning etc.).
- Ensure there is enough mounting space. (see page 2-4 bzw. 2-31)
Several devices can be mounted side by side. Ensure unhindered inlet of cooling air and discharge of exhaust air. Observe mounting clearances of 100 mm above and below.
- In the event of continuous oscillations or vibrations, check the use of vibration dampers.
- Information about installation according to EMC can be found in the 8200 vector System Manual (see page 6-3).

The frequency inverters can be fitted as follows into a control cabinet:

- With the **standard fixtures** included in the scope of (included in the scope of supply)
- With special **fixtures** (power-dependent accessories)

Standard mounting - 8200 vector 0.25 ... 2.2 kW

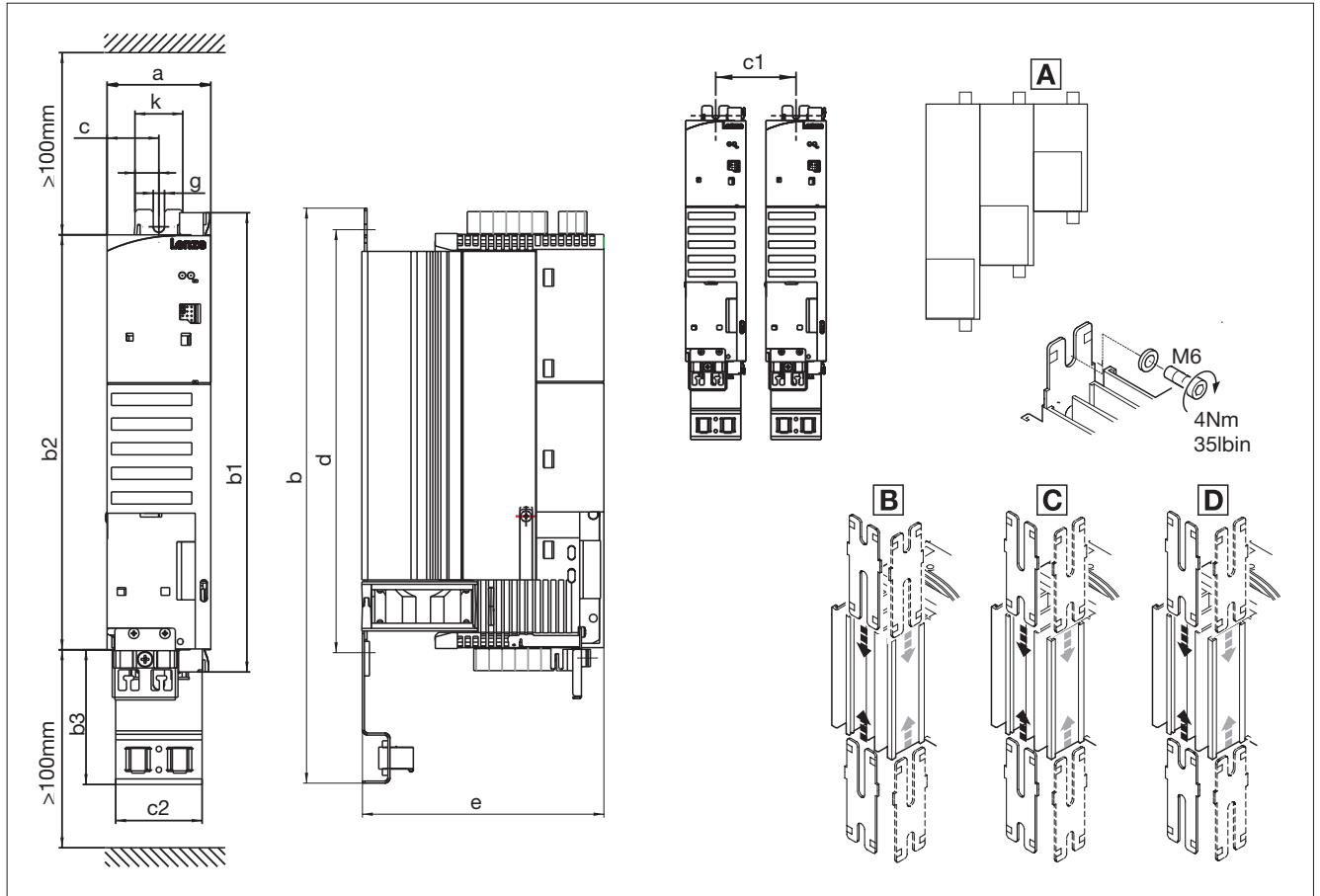

8200 vector Type	Dimensions [mm]															
	a	b			b1	b2	b3	c	c1	c2	d			e	g	k
		B	C	D							B	C	D			
E82EV251K2C E82EV371K2C	60	213	243	263	148	129	78	30	63	50	130...140	120...170	110...200	140	6.5	28
E82EV551KxC E82EV751KxC		273	303	323	208	180					190...200	180...230	170...260			
E82EV152KxC ¹⁾ E82EV222KxC ¹⁾		333 359 ²⁾	363	-	268	240					250...260 280...295 ²⁾	240...290	-	140 162 ²⁾	6.5	28

A Components of different sizes should be mounted adjacent to one another at 3 mm intervals, with the largest furthest to the left and the smallest on the far right.

- 1) Side-by-side mounting is only possible with swivel bracket E82ZJ001 (accessories)
 2) With E82ZJ001

Base controllers

Dimensions and mounting

Standard mounting - 8200 vector 0.25 ... 2.2 kW with substructure RFI filters

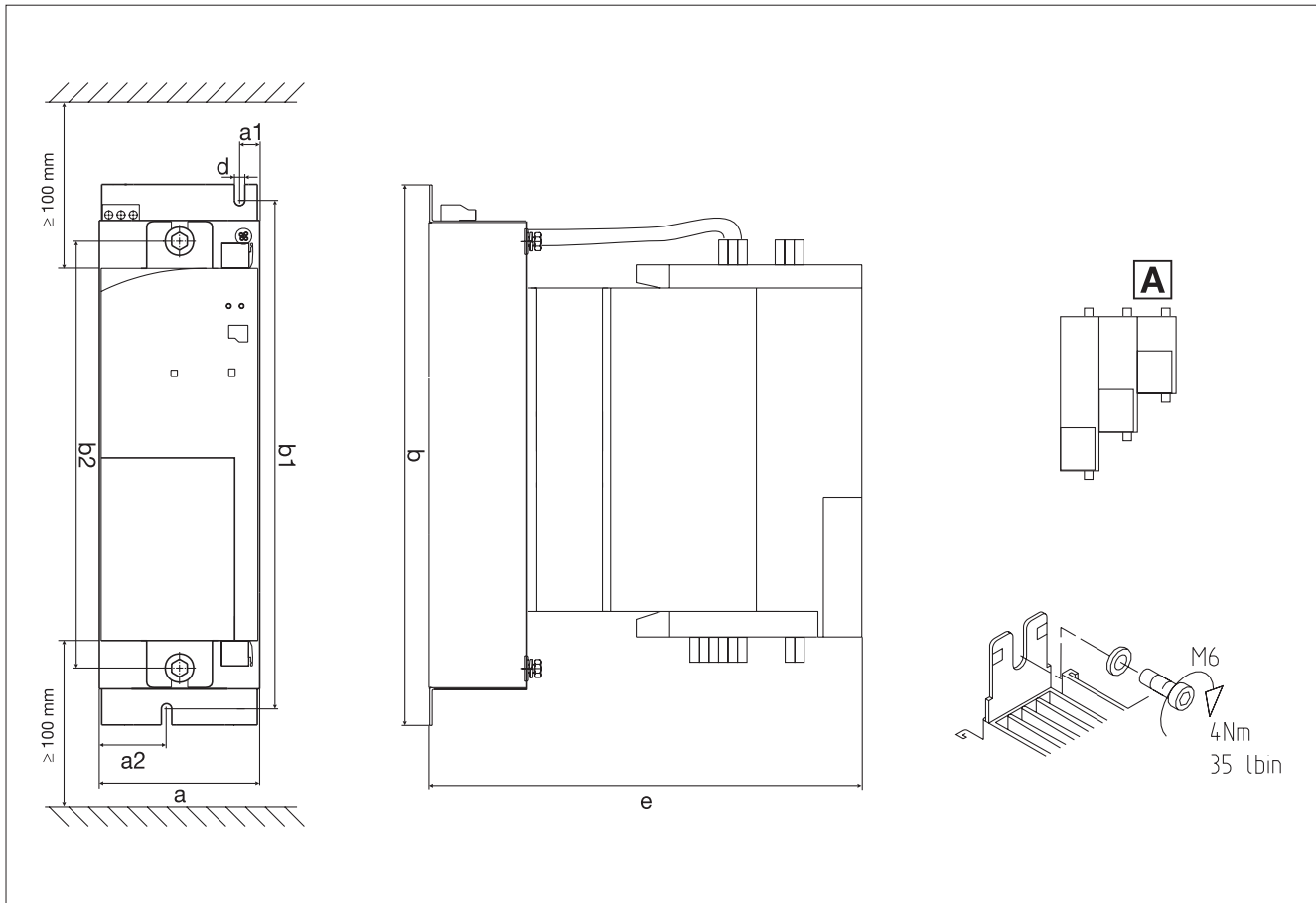

Schematic sketch: Representation without shield connection of motor and control cable.

8200 vector	Dimensions [mm]							
Type	a	a1	a2	b	b1	b2	d	e
E82EV251K2C200 E82EV371K2C200	60	10	25	217	197	135	6.5	170
E82EV551KxC200 E82EV751KxC200				277	247	195		180
E82EV152KxC200 E82EV222KxC200				337	317	255		180

A Components of different sizes should be mounted directly adjacent to one another at 3 mm intervals, with the largest furthest to the left and the smallest on the far right.

Note:
See chapter 4 for details of the substructure filter.

Standard mounting - 8200 vector 3.0 ... 11.0 kW

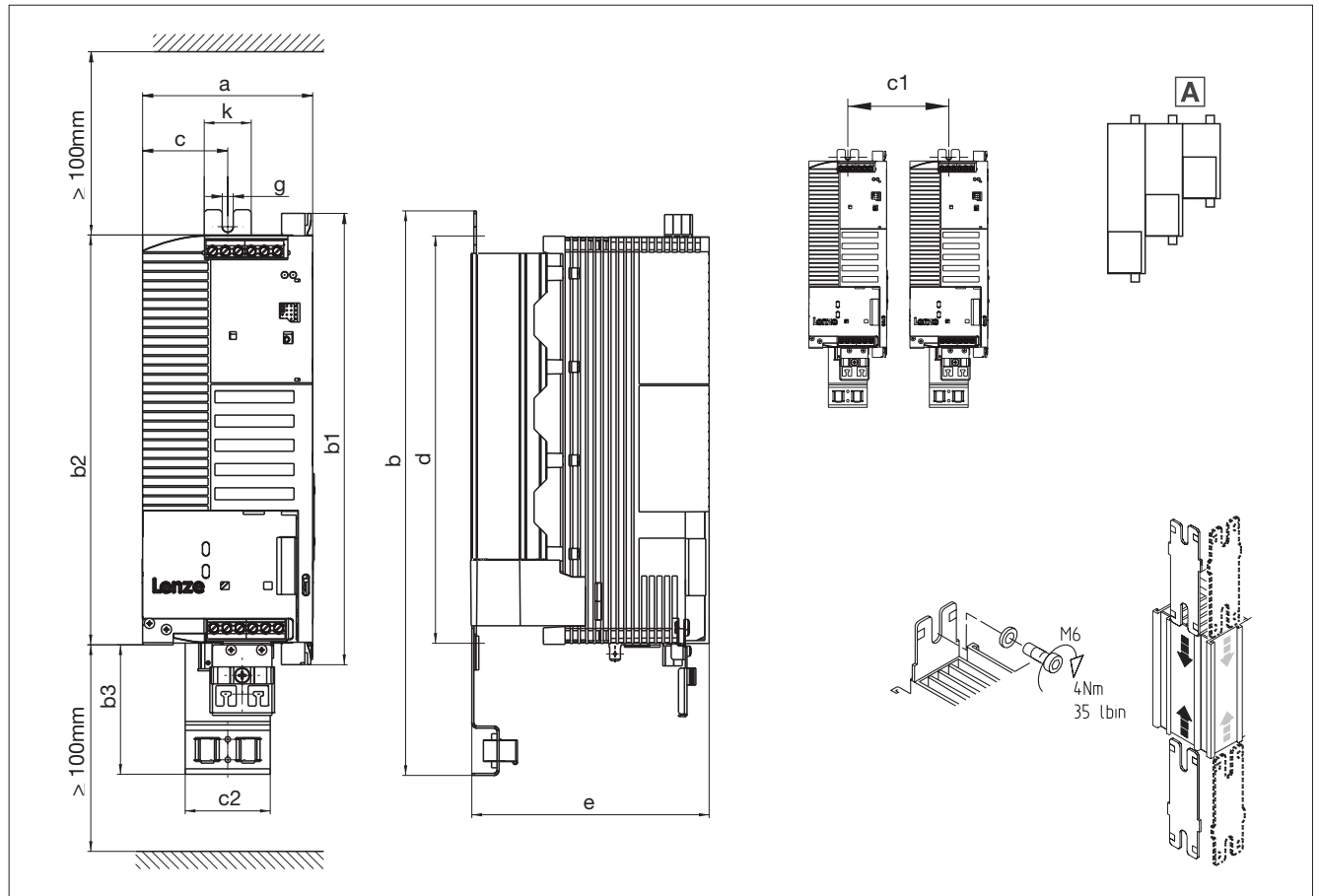

8200 vector	Dimensions [mm]											
Type	a	b	b1	b2	b3	c	c1	c2	d	e	g	k
E82EV302K2C E82EV402K2C	100	333	268	240	78	50	103	50	255	140	6.5	28
E82EV552K2C ¹⁾ E82EV752K2C ¹⁾	125	333 359 ²⁾					62.5					
E82EV302K4C E82EV402K4C E82EV552K4C	100	333				50	103 103 103		255	140		
E82EV752K4C ¹⁾ E82EV113K4C ¹⁾	125	333 359 ²⁾				62.5	128 128		255 280...295 ²⁾	140 162 ²⁾		

A Different sizes should only be mounted side by side with the largest furthest to the left and the smallest on the far right. A clearance of 3 mm must always be observed.

- 1) Side-by-side mounting is only possible with swivel bracket E82ZJ006 (accessories)
- 2) With E82ZJ006

Base controllers

Dimensions and mounting

Standard mounting - 8200 vector 3.0 ... 11.0 kW with substructure RFI filters

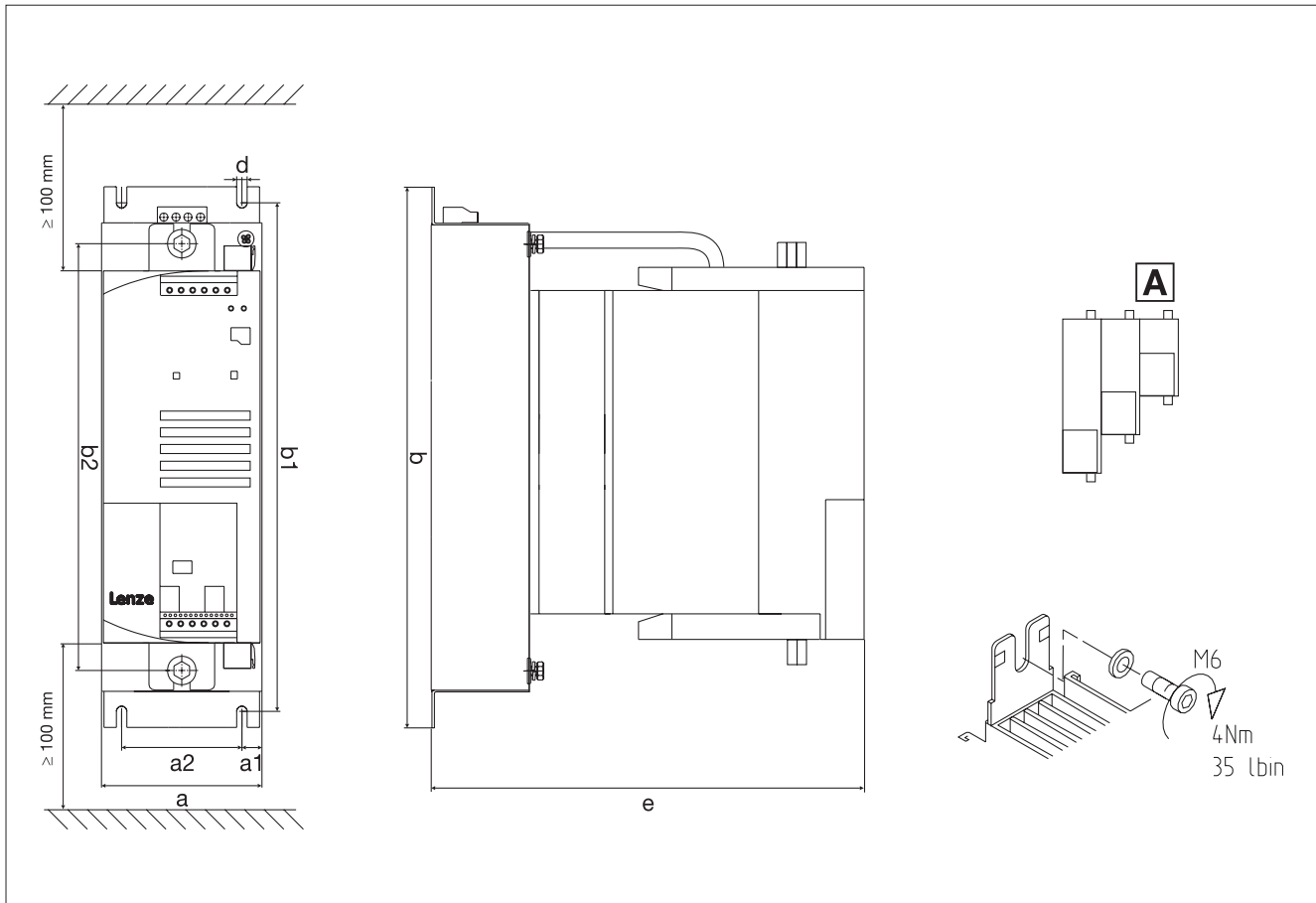

Schematic sketch: Representation without shield connection of motor and control cable.

8200 vector	Dimensions [mm]							
Type	a	a1	a2	b	b1	b2	d	e
E82EV302K2C200 E82EV402K2C200	100	12.5	75	337	317	255	6.5	200
E82EV552K2C200 E82EV752K2C200	125	25						
E82EV302K4C200 E82EV402K4C200 E82EV552K4C200	100	12.5						
E82EV752K4C200 E82EV113K4C200	125	25						

A Different sizes should only be mounted side by side with the largest furthest to the left and the smallest on the far right. A clearance of 3 mm must always be observed.

Note:
See chapter 4 for details of the base filter as an accessory.

Standard mounting - 8200 vector 15.0 ... 90.0 kW

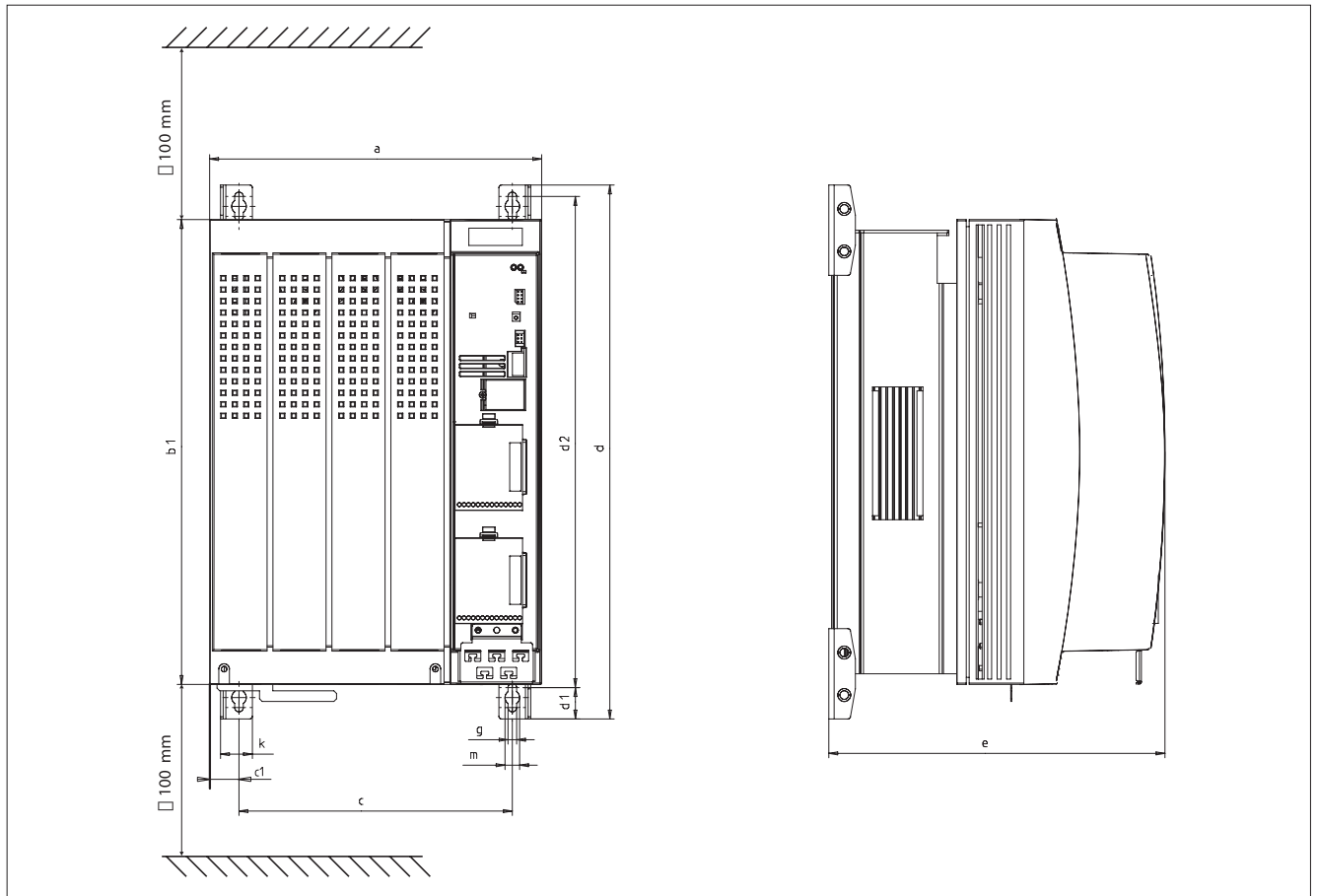

	Dimensions [mm]										
	a	b1	c	c1	d	d1	d2	e	g	k	m
E82EV153K4B201 E82EV223K4B201 E82EV303K4B201	250	350	205	22	402	24	370	250	6.5	24	11
E82EV453K4B201 ¹⁾	340	510	284	28	580	38	532	285	11	28	18
E82EV553K4B201 ¹⁾	340	591	284	28	672	38	624	285	11	28	18
E82EV753K4B201 ¹⁾ E82EV903K4B201 ¹⁾	450	680	395	30.5	750	38	702	285	11	28	18

¹⁾ Ensure clearance of 50 mm around the drive controller in order e.g. to be able to remove eye-bolts.

Base controllers

Dimensions and mounting

Standard mounting - 8200 vector 15.0 ... 90 kW with substructure RFI filters

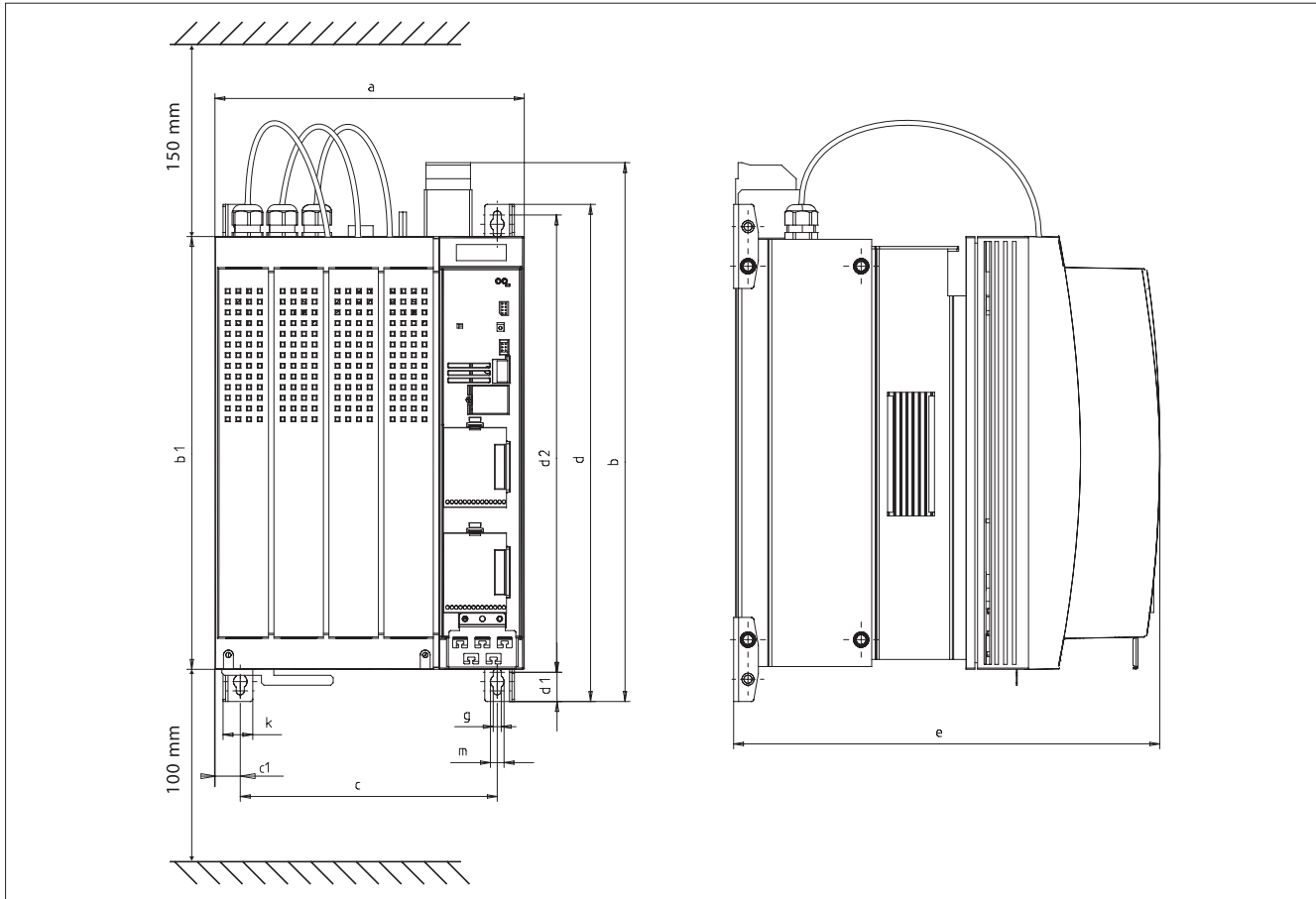

	Dimensions [mm]											
	a	b	b1	c	c1	d	d1	d2	e	g	k	m
E82EV153K4B3xx ¹⁾ E82EV223K4B3xx ¹⁾ E82EV303K4B3xx ¹⁾	250	456	350	205	22	402	24	370	340	6.5	24	11
E82EV453K4B3xx ¹⁾	340	619	510	284	28	580	38	532	375	11	28	18
E82EV553K4B3xx ¹⁾	340	729	591	284	28	672	38	624	375	11	28	18
E82EV753K4B3xx ¹⁾ E82EV903K4B3xx ¹⁾	450	802	680	395	30.5	750	38	702	375	11	28	18

¹⁾ Ensure clearance of 50 mm around the drive controller in order e.g. to be able to remove eye-bolts.

Note:

- The integrated mains filters listed in the accessories section are of different designs and have different dimensions and features to the mains filters listed here (see chapter 4).

Swivel bracket

On housings with a shallow installation depth the frequency inverter can be mounted with a swivel bracket. The frequency inverter can be swivelled out sideways, e.g.

through 90°, for installation, adjustment and diagnostic purposes (mechanism locks at 45°, 90°, 135°, 180°).

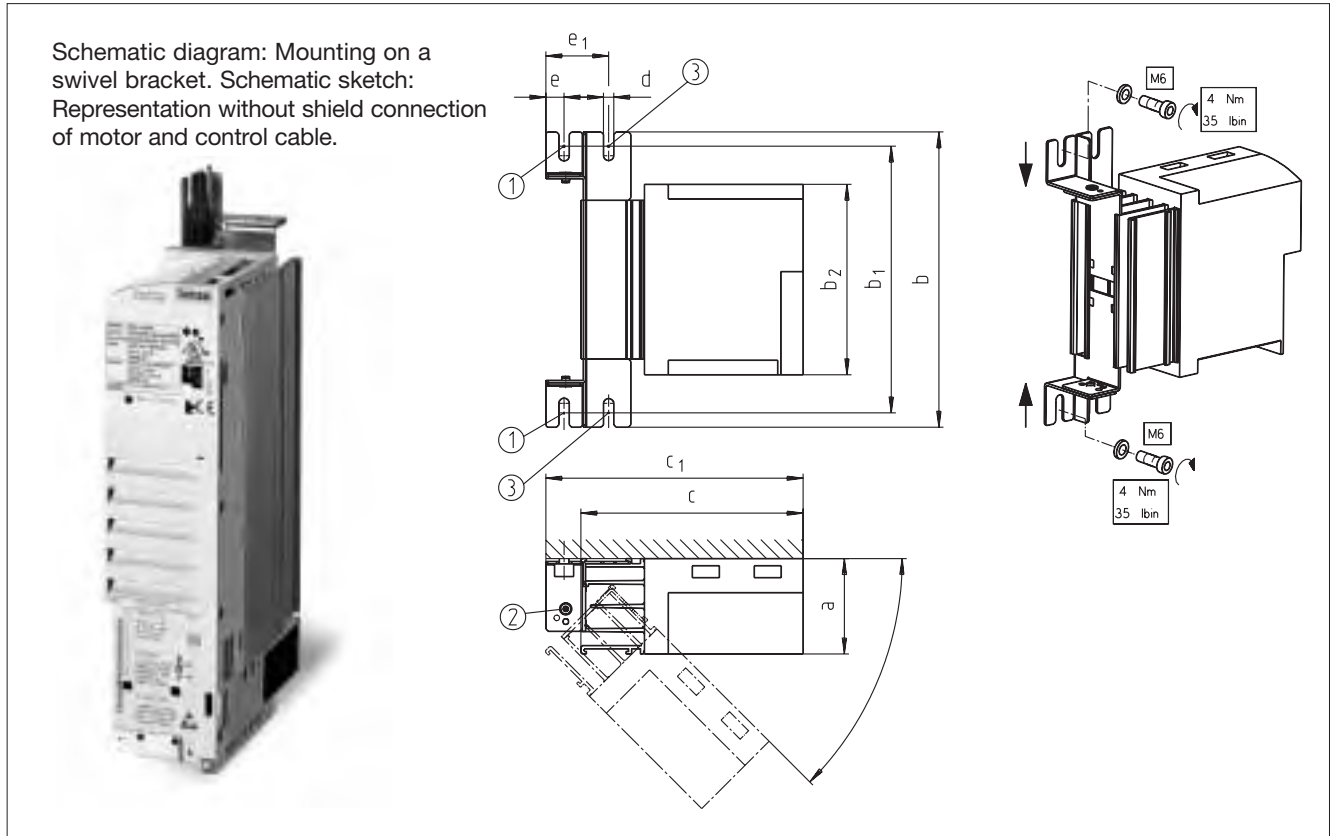

① Bolt here ② Pivot point ③ Bolt here to keep the frequency inverter fixed in the 0°-position

8200 vector	Dimensions [mm]									Order ref.
Type	a	b	b ₁	b ₂	c	c ₁	d	e	e ₁	
E82EV251K2C E82EV371K2C	60	186	160...175	120	140	162	6.5	11.5	39	E82ZJ001
E82EV551K2C E82EV751K2C		246	220...235	180						
E82EV152K2C E82EV222K2C		306	280...295	240						
E82EV551K4C E82EV751K4C		246	220...235	180						
E82EV152K4C E82EV222K4C		306	280...295	240						
E82EV302K2C E82EV402K2C	100	306	280...295	240	140	162	6.5	11.5	39	E82ZJ005
E82EV552K2C E82EV752K2C	125									E82ZJ006
E82EV302K4C E82EV402K4C E82EV552K4C	100									E82ZJ005
E82EV752K4C E82EV113K4C	125									E82ZJ006

Note:

- The bracket must be used for secure side mounting on the following devices:
230 V: 1.5/2.2/5.5 kW, 400 V: 7.5/11.0 kW.
- For installation according to EMC standard mounting ist preferable to swivel backet mounting.

Base controllers

Dimensions and mounting

DIN rail mounting - 8200 vector 0.25 ... 2.2 kW

DIN rail mounting	Order ref.	E82ZJ002
-------------------	------------	----------

8200 vector frequency inverters can be mounted on DIN rails using a special fixture (35 x 7.5 or 35 x 15) in accordance with EN 50022.

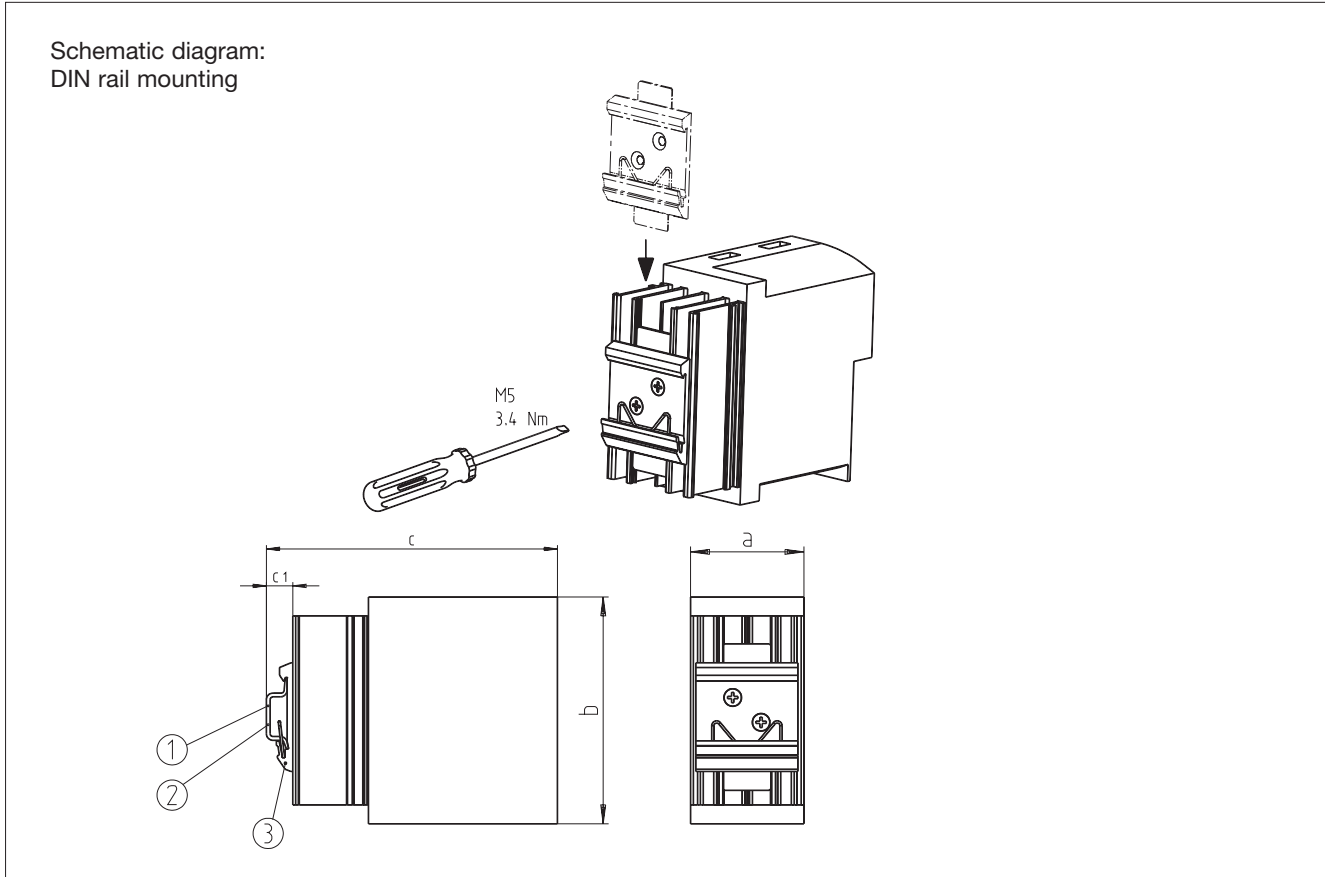

① DIN rail 35 x 15 or ② DIN rail 35 x 7.5 ③ DIN rail mounting

TIP: • The DIN rail fixture can be moved flexibly on the rear panel of the 8200 vector.

• 8200 vector 1.5/2.2 kW inverters (types E82EV152KxB/E82EV222KxB) can also be mounted on 2 DIN rails (2 x E82ZJ002 required)

8200 vector Type	Dimensions [mm]						
	a	b	c		c ₁		
			①	②	①	②	
E82EV251K2C E82EV371K2C	60	120	158	151	18	11	
E82EV551K2C E82EV751K2C		180					
E82EV152K2C E82EV222K2C		240					
E82EV551K4C E82EV751K4C		180					
E82EV152K4C E82EV222K4C		240					

Note:

For installation according to EMC standard mounting is preferable to DIN rail mounting.

8200 vector in “cold plate” technology

8200 vector frequency inverters in “cold plate” technology (types E82CVxxxKxx) dissipate their waste heat (heat loss) via a cooler appropriate for the application (e.g. cumulative cooler). For this purpose the frequency inverters are equipped with a bare metal cooling plate in place of a heatsink. This is connected to a separate heatsink via a thermal link.

The use of “cold plate” technology is recommended if

- There are a lot of pollutants in the surrounding air preventing the use of external fans for cooling (e.g. control cabinet fans)
- The control cabinet selected must have a high IP degree of protection (e.g. IP 65)
- The waste heat is to be dissipated via a medium (e.g. water, oil)
- A cumulative cooler is to be incorporated for all of the frequency inverters
- Installation space is limited

Notes:

- The features, technical data and rating data shown on pages 2-4 apply; see mounting and dimensions on the following pages.
- The 8200 vector frequency inverter in “cold plate” technology is a special design. It is available on request.
- The 8200 vector frequency inverter in “cold plate” technology is supplied with integrated RFI filters up to 11 kW.
- All 8200 vector frequency inverters are approved in accordance with UL508C. However, devices in “cold plate” technology must be mounted by the user to ensure that the approved features are provided. Therefore these frequency inverters bear the UR mark (instead of the UL mark).



Cooler requirements

The power losses of the frequency inverters can be dissipated via coolers operating with various cooling media (air, water, oil etc.).

The following points are important to ensure safe and reliable operation of the frequency inverters:

- Good thermal connection to the cooler
 - The contact area between the cooler and the frequency inverter must be at least as large as the cooling plate of the frequency inverter.

- Level contact surface, deviations up to a maximum of 0.05 mm

- Connect the cooler and the cooling plate using all the screw connections prescribed.

- Do not exceed the maximum temperature of the frequency inverter cooling plate (75°C) .
- Adhere to the thermal resistance R_{th} (transition between cooler and cooling medium) specified in the table. The values apply to the operation of the frequency inverters under the rated conditions.

8200 vector			Thermal resistor
Type ref./Order ref.	Power [kW]	Dissipated power loss P_{loss} [W]	R_{th} [K/W]
E82CV251K2C	0.25	15	≤ 1.5
E82CV371K2C	0.37	20	≤ 1.5
E82CV551K2C	0.55	30	≤ 1.0
E82CV751K2C	0.75	40	≤ 1.0
E82CV152K2C	1.5	70	≤ 0.3
E82CV222K2C	2.2	100	≤ 0.3
E82CV302K2C	3.0	110	≤ 0.23
E82CV402K2C	4.0	150	≤ 0.23
E82CV552K2C	5.5	205	≤ 0.13
E82CV752K2C	7.5	270	≤ 0.13
E82CV551K4C	0.55	30	≤ 1.0
E82CV751K4C	0.75	40	≤ 1.0
E82CV152K4C	1.5	65	≤ 0.3
E82CV222K4C	2.2	100	≤ 0.3
E82CV302K4C	3.0	110	≤ 0.23
E82CV402K4C	4.0	140	≤ 0.23
E82CV552K4C	5.5	190	≤ 0.23
E82CV752K4C	7.5	255	≤ 0.13
E82CV113K4C	11.0	360	≤ 0.13
E82CV153K4B201	15.0	410	≤ 0.085
E82CV223K4B201	22.0	610	≤ 0.057

Technical data

The data for the corresponding E82EVxxx base controllers apply, see page 2-8.

Mounting the 8200 vector in "cold plate" technology 0.25 ... 2.2 kW

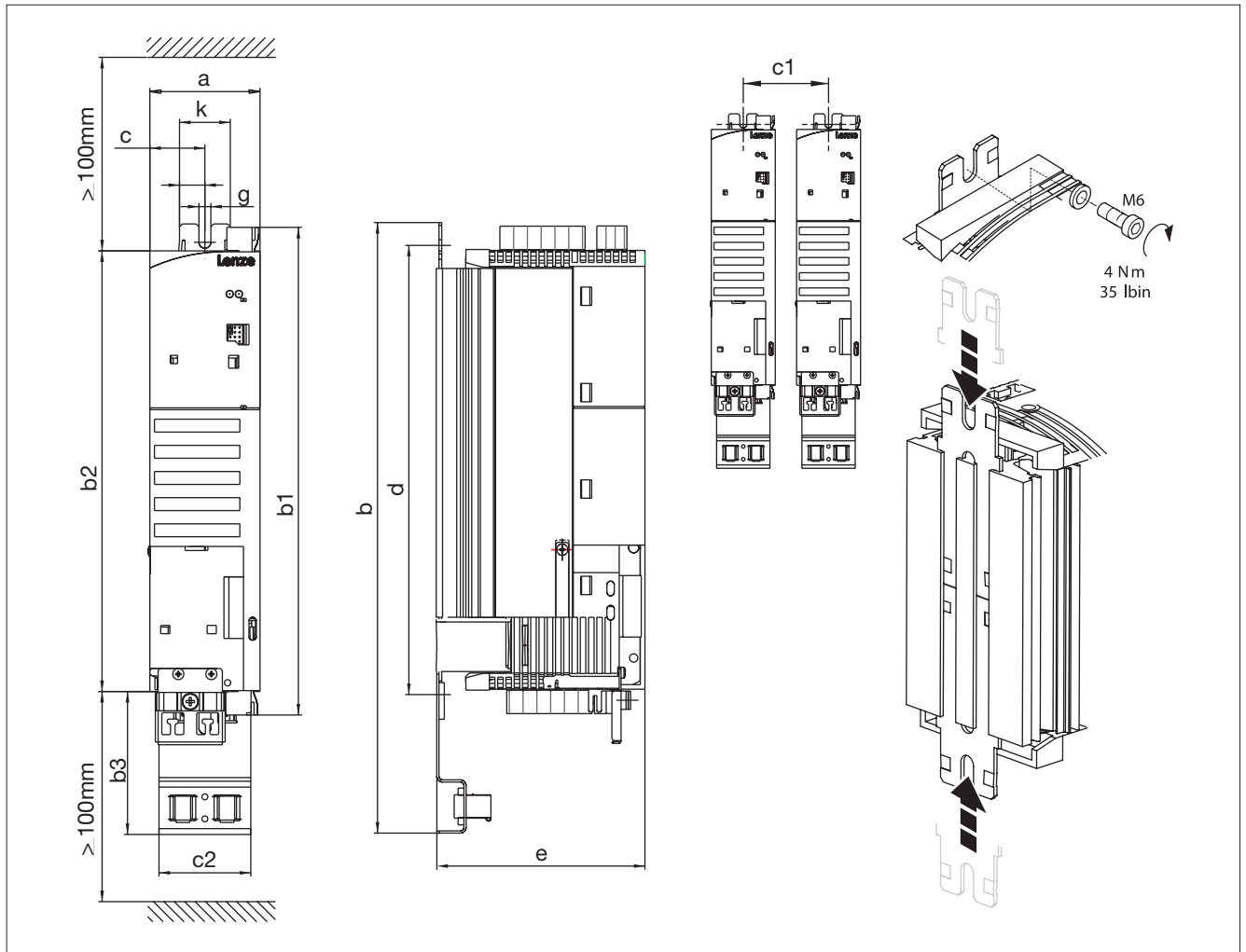

8200 vector	Dimensions [mm]												
Type	a	b	b1	b2	b3	c	c1	c2	d	e	g	k	Weight [kg]
E82CV251K2C E82CV371K2C	60	213	148	129	78	30	63	50	130...140	106	6.5	28	0.6
E82CV551KxC E82CV751KxC		273	208	180					190...200				0.9
E82CV152KxC E82CV222KxC		333	268	240					250...260				1.1

Base controllers

Special designs

Mounting the 8200 vector in "cold plate" technology 3 ... 11 kW

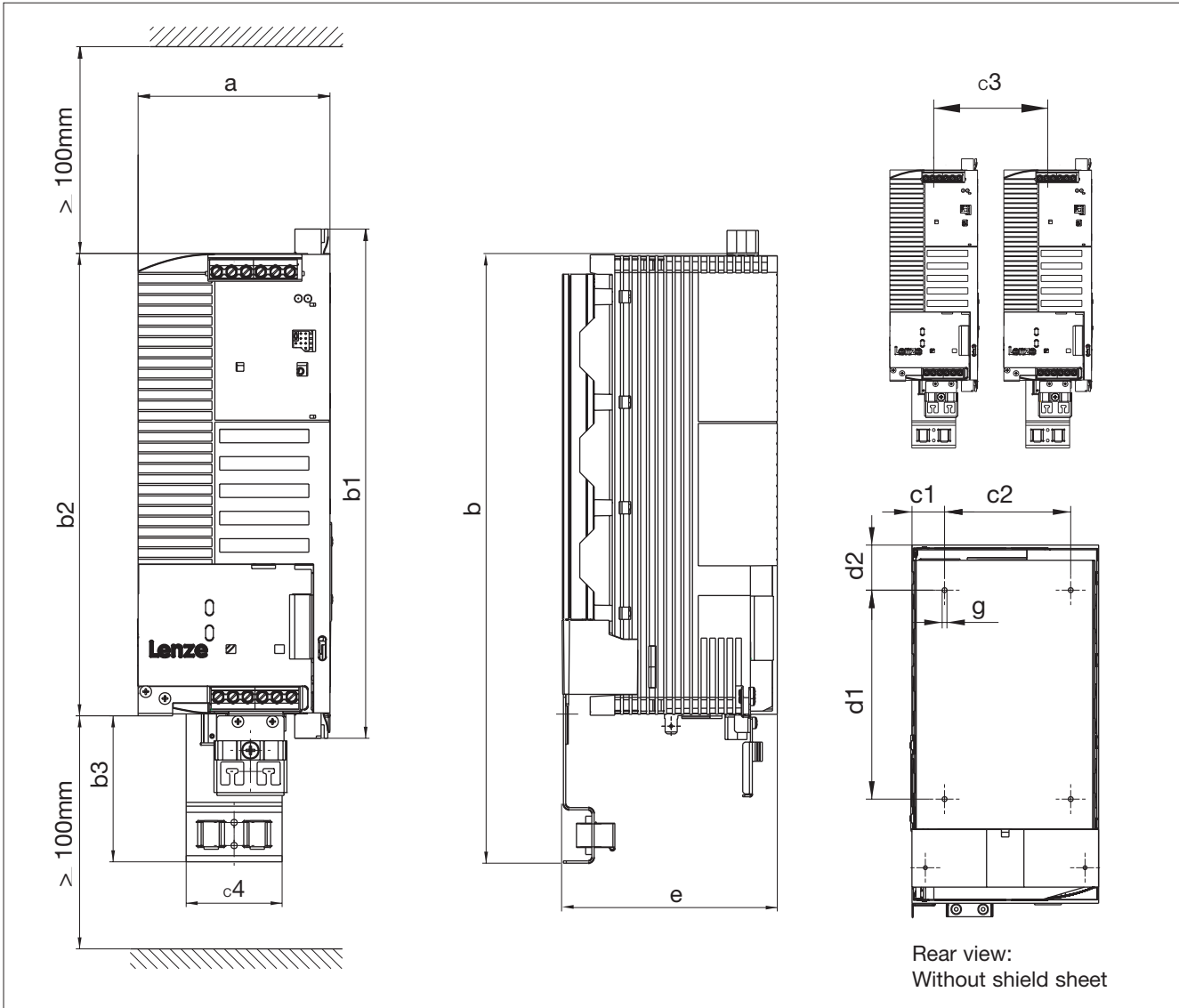

8200 vector	Dimensions [mm]												
Type	a	b	b1	b2	b3	c1	c2	c3	c4	d1	d2	e	g
E82CV302K2C E82CV402K2C	100	318	268	240	78	19	62.5	103	50	140	30	106	M4 10 deep
E82CV552K2C E82CV752K2C	22					84.5	128						
E82CV302K4C E82CV402K4C E82CV552K4C	19					62.5	103						
E82CV752K4C E82CV113K4C	22					84.5	128						

Mounting the 8200 vector in "cold plate" technology 15 ... 22 kW

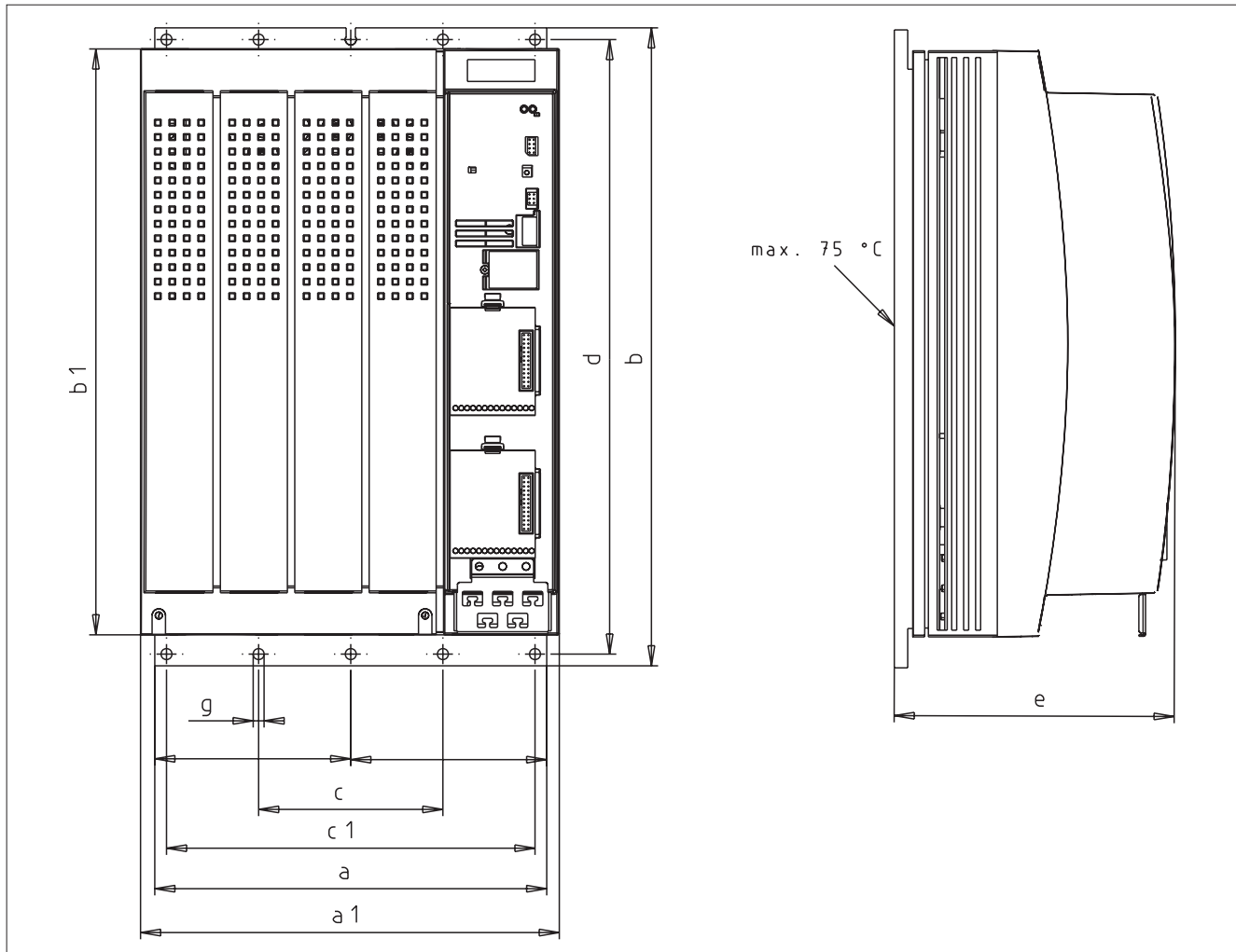

8200 vector	Dimensions [mm]								
Type ref./Order ref.	a	a1	b	b1	c	c1	d	e	g
E82CV153K4B									
E82CV223K4B	234	250	381	350	110	220	367	171	6.5

Push-through technology

The “push-through technology” special design of the 8200 vector frequency inverter enables the waste heat in the control cabinet to be reduced. The frequency inverter is mounted in the control cabinet in such a way that the inverter heatsink is located outside the cabinet. This means that almost all the waste heat from the inverter can be dissipated outside the control cabinet by means of convection or forced cooling.

The “push-through technology” special design is particularly suitable for applications in which self-ventilation via the control cabinet surface is insufficient. The “push-through technology” special design enables air conditioners or fans with lower ratings to be used or, in some cases, to be left out altogether. Depending on the frequency inverter, degrees of protection up to IP65 can be achieved. This means that the inverters can be used in harsh industrial environments. The “push-through technology” special design is available in the power range from 0.25 to 90 kW. More detailed information can be found on the following pages.

Note: The 8200 vector frequency inverter in “push-through technology” is a special design. It is available on request.



Mounting the 8200 vector in "push-through technology" 0.25 ... 0.75 kW

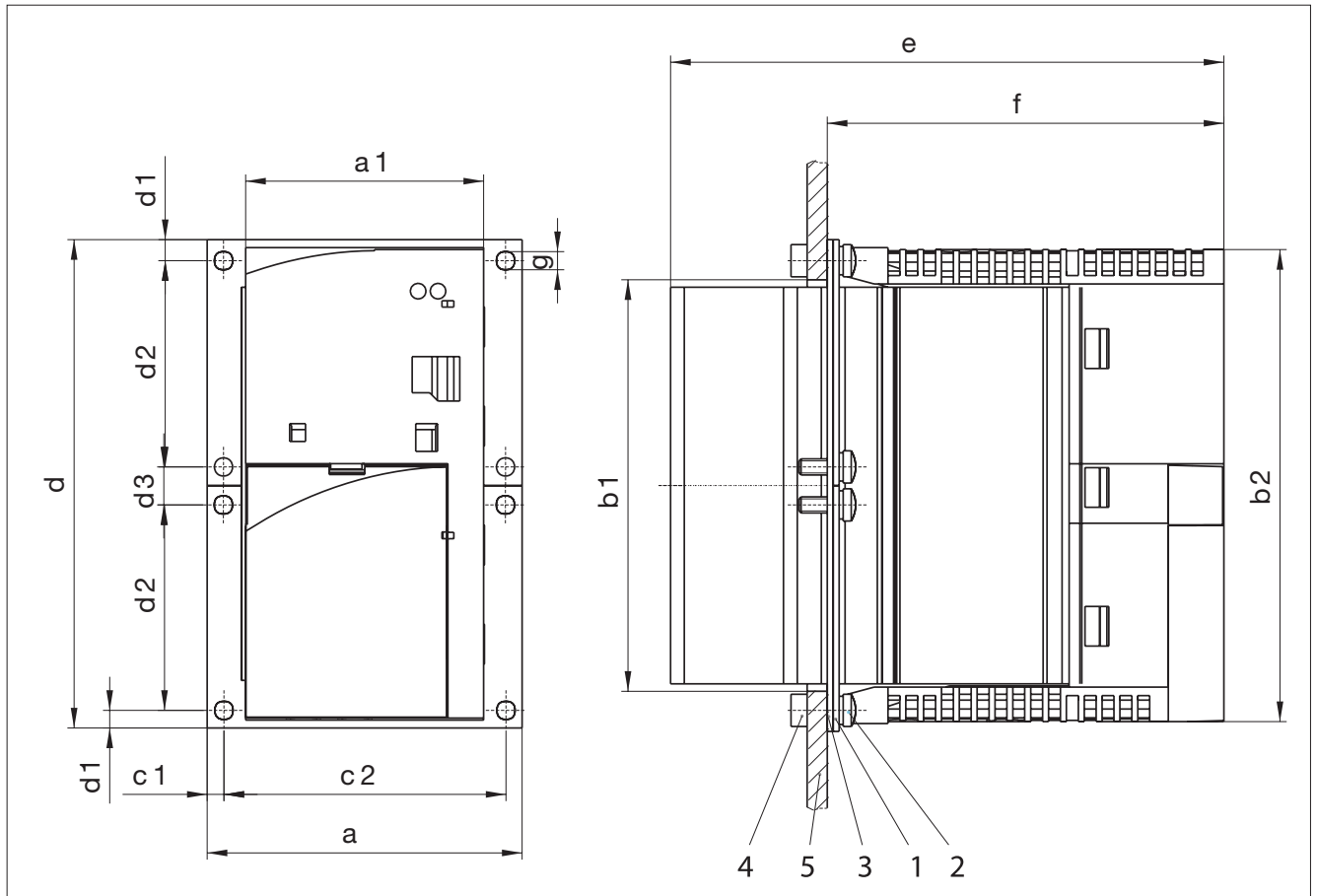

- 1 Base frame
- 2 Screw M4x10
- 3 Seal
- 4 Hex nut M4
- 5 Back panel of control cabinet

Schematic sketch: Representation without shield connection of motor and control cable.

8200 vector	Dimensions [mm]										
Type ref./Order ref.	a	b	b2	c1	c2	d1	d2	d3	e	f	g
E82DV251K2C	79.4	124	120	4.2	71	5	52	10	140	100	4.5
E82DV371K2C		184	180				82				
E82DV551K2C											
E82DV751K2C											
E82DV551K4C											
E82DV751K4C											

Cut-out in the control cabinet

8200 vector	Dimensions [mm]		
Type ref./Order ref.	a1	b1	
E82DV251K2C	61	101	
E82DV371K2C		161	
E82DV551K2C			
E82DV751K2C			
E82DV551K4C			
E82DV751K4C			

Base controllers

Special designs

Mounting the 8200 vector in "push-through technology" 1.5 ... 2.2 kW

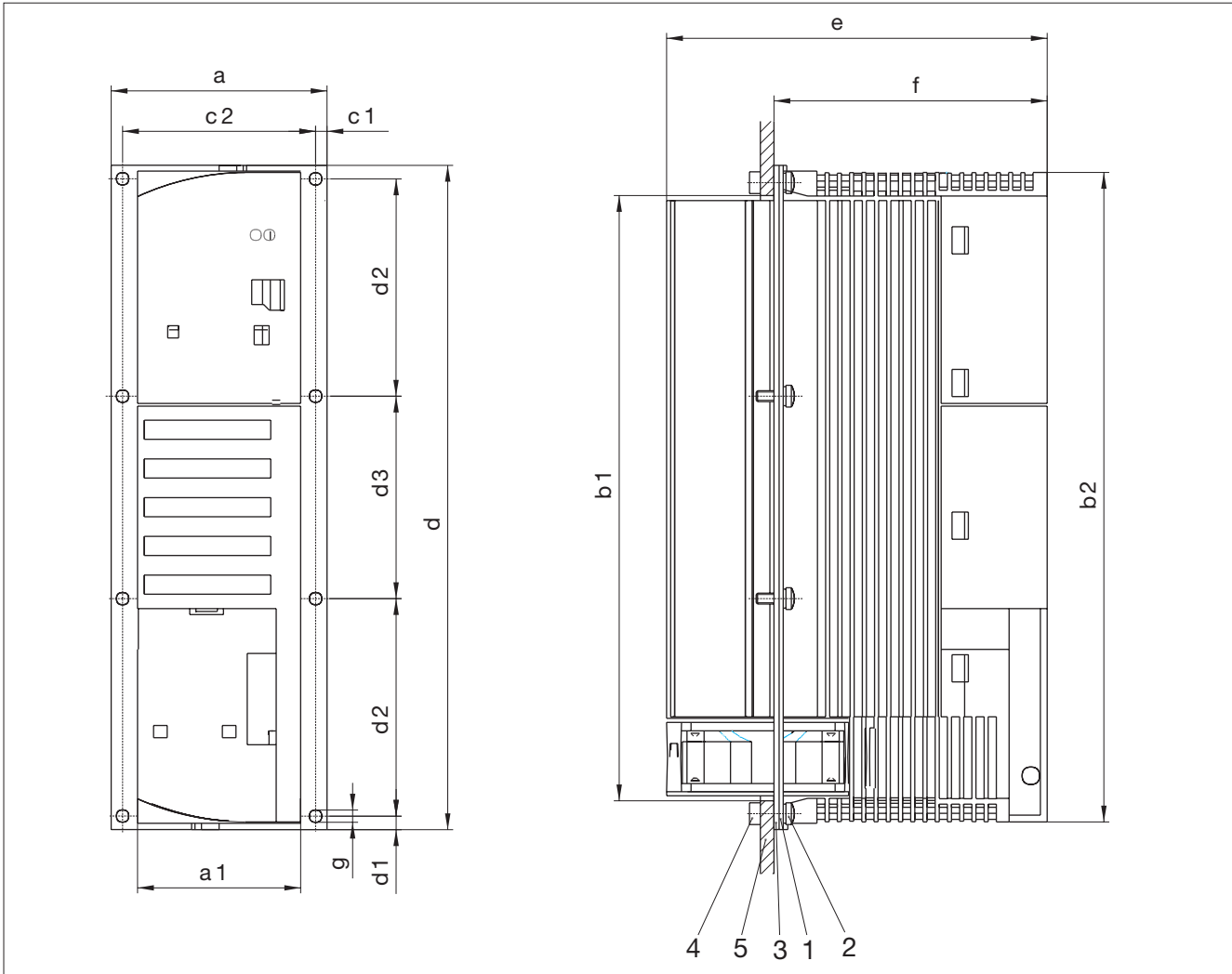

- 1 Base frame
- 2 Screw M4x10
- 3 Seal
- 4 Hex nut M4
- 5 Back panel of control cabinet

Schematic sketch: Representation without shield connection of motor and control cable.

8200 vector	Dimensions [mm]										
Type ref./Order ref.	a	b	b2	c1	c2	d1	d2	d3	e	f	g
E82DV152K2C	79.4	244.5	240	4.2	71	5	80	74.5	140	100	4.5
E82DV222K2C											
E82DV152K4C											
E82DV222K4C											

Cut-out in the control cabinet

8200 vector	Dimensions [mm]	
Type ref./Order ref.	a1	b1
E82DV152K2C	61	221
E82DV222K2C		
E82DV152K4C		
E82DV222K4C		

Mounting the 8200 vector in "push-through technology" 3 ... 11 kW

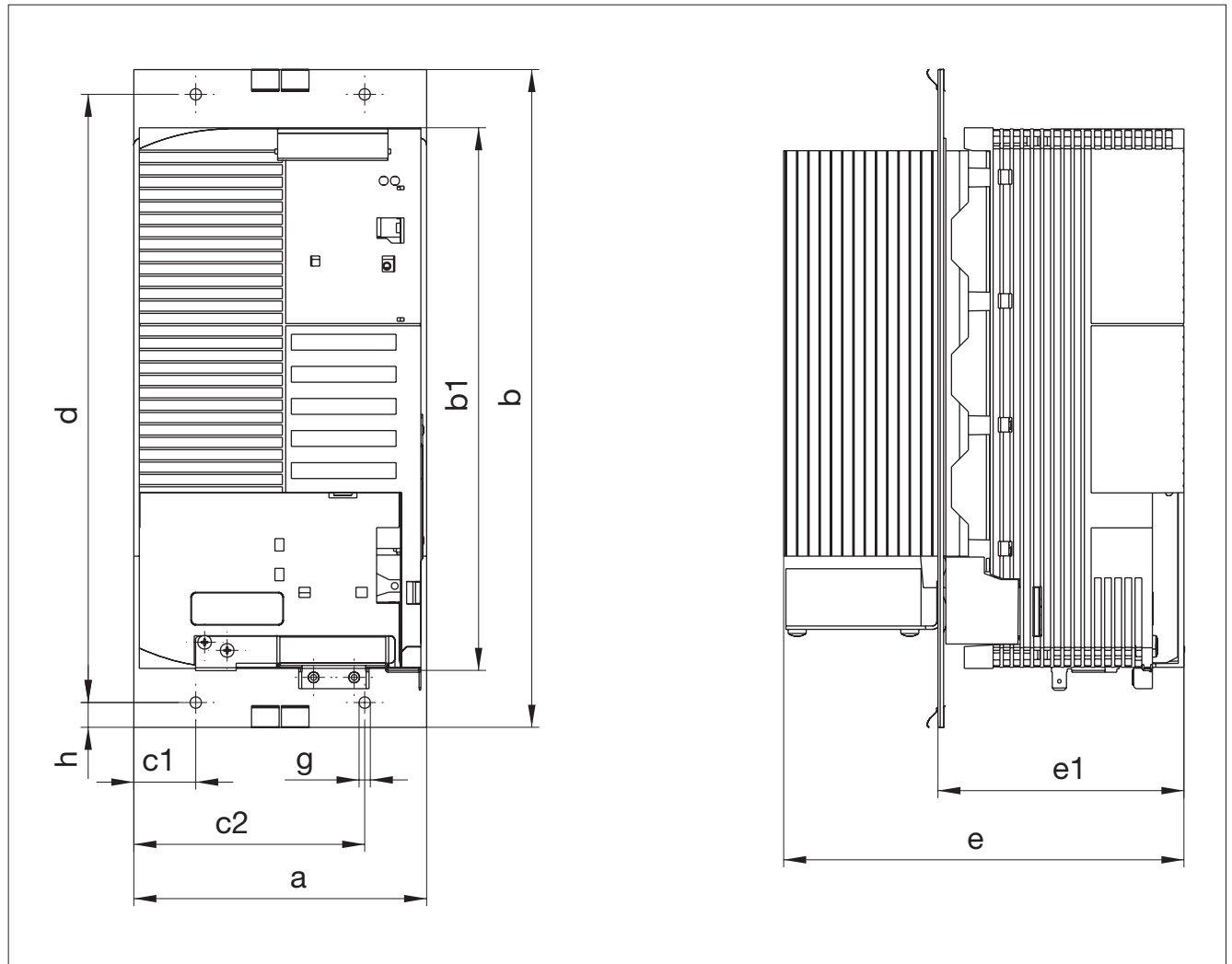

Schematic sketch: Representation without shield connection of motor and control cable.

8200 vector	Dimensions [mm]									
Type ref./Order ref.	a	b	b1	c1	c2	d	e	e1	g	h
E82DV302K2C E82DV402K2C	100	292	240	25	75	270	178	109,5	5	11
E82DV552K2C E82DV752K2C	130	292	240	27,5	102,5	270	178	109,5	5	11
E82DV302K4C E82DV402K4C E82DV552K4C	100	292	240	25	75	270	178	109,5	5	11
E82DV752K4C E82DV113K4C	130	292	240	27,5	102,5	270	178	109,5	5	11

Base controllers

Special designs

Mounting the 8200 vector in "push-through technology" 15 ... 30 kW

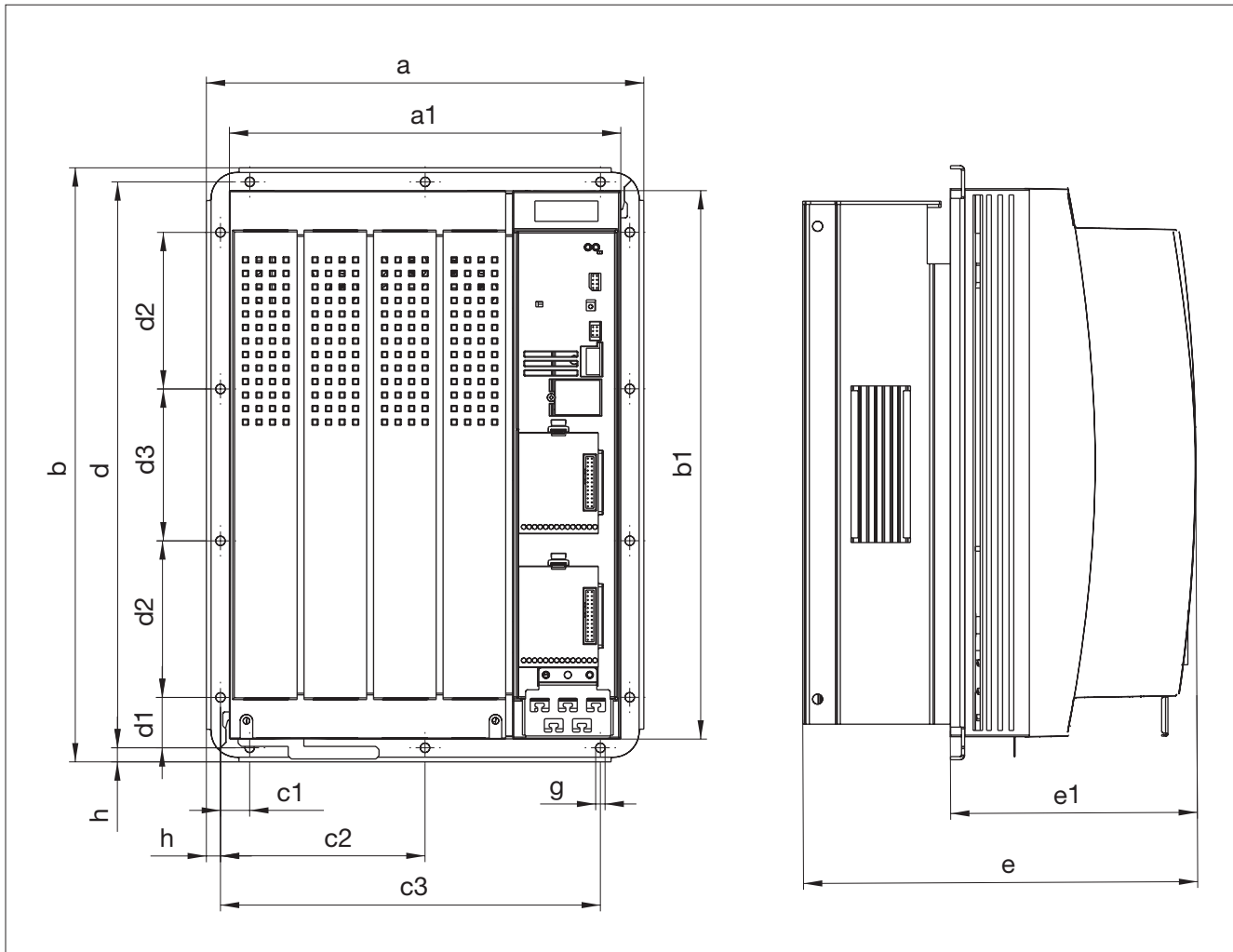

8200 vector	Dimensions [mm]															
	Type ref./Order ref.	a	a1	b	b1	c1	c2	c3	d	d1	d2	d3	e	e1	g	h
E82DV153K4B																
E82DV223K4B	279.5	250	379.5	350	19	131	261.5	361.5	32	100	97	250	159.5	4.2	9	
E82DV303K4B																

Mounting the 8200 vector in "push-through technology" 45 ... 90 kW

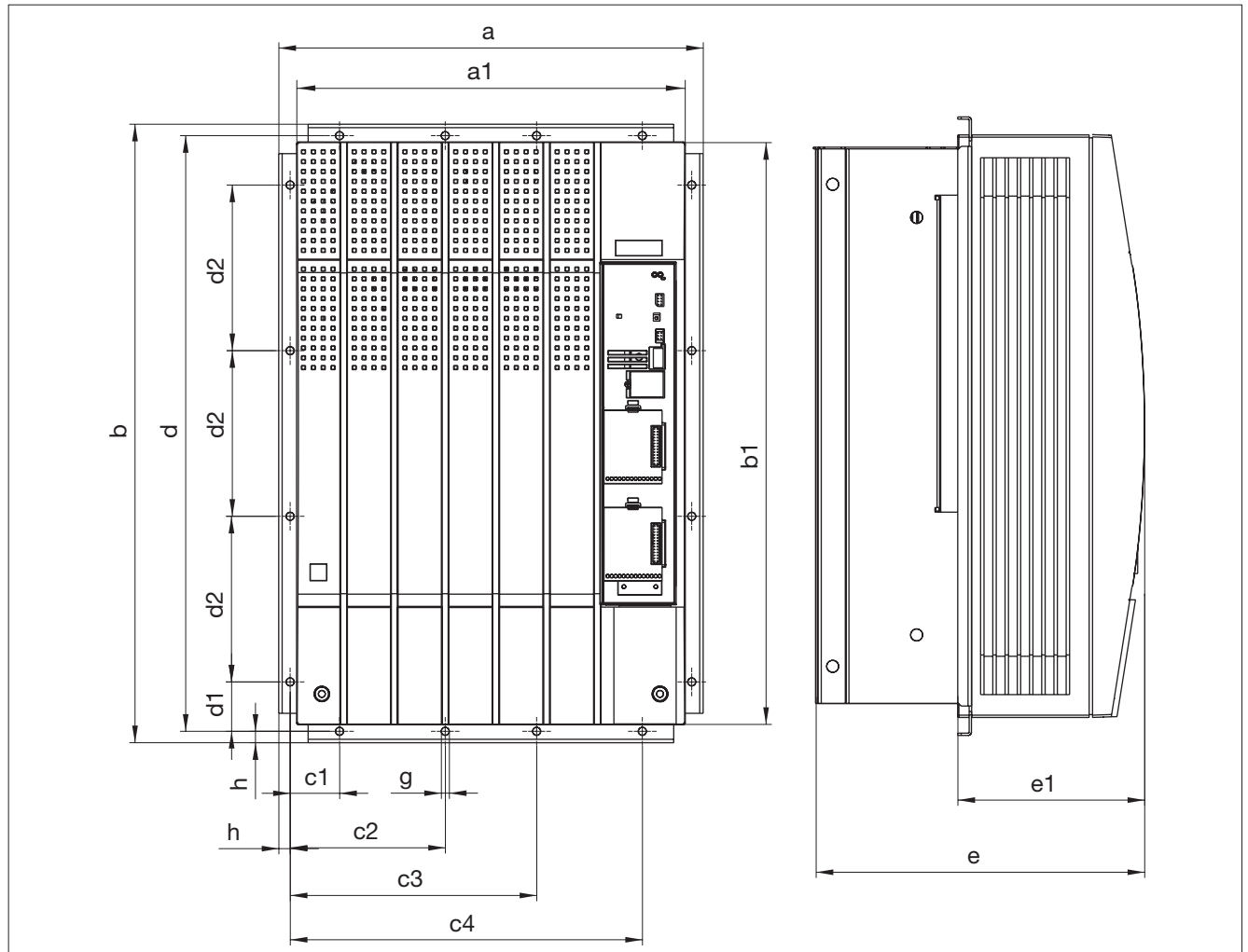

8200 vector	Dimensions [mm]														
Type ref./Order ref.	a	a1	b	b1	c1	c2	c3	c4	d	d1	d2	e	e1	g	h
E82DV453K4B E82DV553K4B	373	340	543	510	45	92.5	172.5	265	525	45	145	285	163.5	7	9
E82DV753K4B E82DV903K4B	488	450	718	680	49	172.5	295.5	419	698	49	200	285	163.5	9	10

Version for “safe stop” safety technology

The “safe stop” special version supports the “safe stop” safety function, providing protection against unexpected start-up in accordance with the requirements of EN 954-1 “Control Category 3” and EN 1037. The safety relay electrically isolates the voltage supply to the optocoupler for the purposes of pulse transmission to the IGBT. It must be activated externally with +24 V DC.

In comparison to the solution using a motor contactor, this variant offers the following advantages:

- An external motor contactor is not required
- Reduces wiring
- Space saving
- Improved EMC: The motor cable shield must not be interrupted

With the “safe stop” function, an “emergency stop” is not possible without additional measures:

- There is no electrical isolation between the motor and the drive controller and no “service switch” or “repair switch”
- Electrical isolation is required for an “emergency stop” e.g. by means of a central mains contactor

Note: The “safe standstill” 8200 vector frequency inverter is a special version. It is available on request.

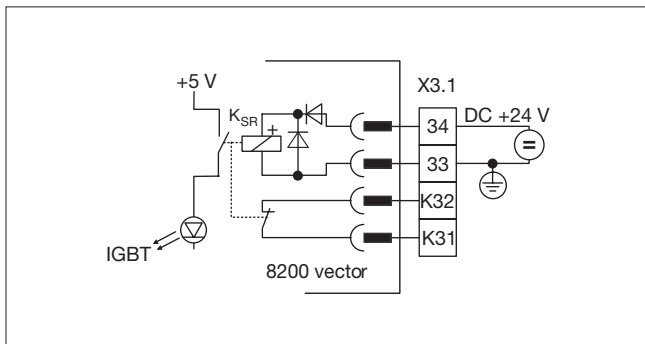

Terminal assignment		Data		
33	Reference potential for the input Emergency stop	Safety relay	Coil voltage at +40°C	+24 V DC (+19.5...36 V)
34	Emergency stop input		Current at 24 V DC	30 mA
			Test voltage contact τ coil	1500 V AC _{rms} for 1 min
			Test voltage contact τ contact	1500 V AC _{rms} for 1 min
			Electr. service life at rated load	~10 ⁷ operating cycles
			Mechanical service life	~10 ⁷ operating cycles
K31	Feedback contact	Feedback contact	Switching voltage	24 V DC
K32			Continuous current	5...700 mA

8200 vector		
Type/Order ref. 1)	Voltage [V]	Power [kW]
E82EV302K4C040	3 ~ 400V	3.0
E82EV402K4C040		4.0
E82EV552K4C040		5.5
E82EV752K4C040		7.5
E82EV113K4C040		11.0
E82EV153K4B241		15.0
E82EV223K4B241		22.0
E82EV303K4B241		30.0
E82EV453K4B241		45.0
E82EV553K4B241		55.0
E82EV753K4B241		75.0
E82EV903K4B241		90.0

¹⁾ The technical data corresponds to that for E82EVxxx inverters (see page 2-8).

Version for isolated supply systems (IT systems)

The “IT system” special version enables the 8200 vector frequency inverter to be connected to isolated supply systems. The frequency inverters are designed with electrical isolation. This prevents the activation of isolation monitoring, even if more than one frequency inverter has been installed.

The electric strength of the frequency inverters is thus increased, so that even in the event of an isolation fault or earth fault in the supply system, they will not be damaged. The operational safety of the system is not affected.

Note: The IT system version of the 8200 vector is a special version. It is available on request.

8200 vector		
Type/Order ref. ¹⁾	Voltage [V]	Power [kW]
E82EV153K4B101	3 ~ 400V	15.0
E82EV223K4B101		22.0
E82EV303K4B101		30.0
E82EV453K4B101		45.0
E82EV553K4B101		55.0
E82EV753K4B101		75.0
E82EV903K4B101		90.0

¹⁾ The technical data corresponds to that for E82EVxxx inverters (see page 2-8).

The 9300 vector range of frequency inverters also offers frequency inverters for operation on IT systems in the power range from 0.25 ... 90 kW.



Automation | 8200 vector

Overview	3-2
Diagnostics and parameterisation	3-6
Keypad XT – Operating module	3-6
Parameterisation software Global Drive Control (GDC)	3-8
I/O function modules	3-10
Standard I/O PT (terminal module)	3-10
Application I/O PT (terminal module with additional functions)	3-12
Fieldbus function modules	3-14
CAN PT (system bus)	3-14
CAN-I/O PT	3-16
PROFIBUS-DP PT	3-18
INTERBUS PT	3-20
LECOM-B PT (RS485)	3-22
AS-Interface PT	3-24
Communication modules	3-26
CAN/CANopen	3-26
DeviceNet	3-27
PROFIBUS	3-28
INTERBUS	3-29
INTERBUS Loop	3-30
LON	3-31
LECOM-AB (RS 232/485)	3-32
LECOM-LI (optical fibres)	3-33
Automation components	3-34
Drive PLC	3-34
Extension board (I/O extension)	3-41
I/O terminals (bus-compatible)	3-42
Process visualisation (HMI)	3-43

Function and communication modules

Lenze can provide a wide range of components for integration into the automation of the machine or system. The function modules and communication modules enable the inverter to be adapted according to the specific requirements of the application in terms of the number of digital and analog inputs and outputs and in terms of interfacing with the fieldbus. The inverter has two interfaces, one of which can be fitted with a communication module and the other with a function module. The possible combinations of function and communication modules are listed in the table below. An additional interface for another function module is available in the power range from 15.0...90 kW. In this way, for example, the frequency inverter can be operated in parallel during simultaneous bus and I/O operation. This makes start-up and diagnostics easier, particularly in complex applications (fieldbus operation and I/O mixed operation).

Communication module, e.g.

- Keypad
- LECOM-AB (RS232/485)
- LECOM-LI (optical fibres)
- PROFIBUS-DP
- LON
- CAN
- CANopen
- DeviceNet
- INTERBUS
- INTERBUS Loop

Function module, e.g.

- Standard I/O PT
- Application I/O PT
- LECOM-B PT (RS485)
- PROFIBUS-DP PT
- CAN PT (system bus)
- CAN I/O PT (system bus)
- INTERBUS PT
- AS-Interface PT



8200 vector 0,25...11 kW



8200 vector 15...90 kW

Communication module, e.g.

Slot 1:

- Keypad
- LECOM-AB (RS232/485)
- LECOM-LI (optical fibres)
- PROFIBUS-DP
- LON
- CAN
- CANopen
- DeviceNet
- INTERBUS
- INTERBUS Loop

Function module, e.g.

Slot 2:

- LECOM-B PT (RS485)
- PROFIBUS-DP PT
- CAN PT (system bus)
- CAN I/O PT (system bus)
- INTERBUS PT
- Application I/O PT

Function module, e.g.

Slot 3:

- Standard I/O PT ¹⁾
- AS-Interface PT ¹⁾

Combination options for function modules and communication modules

	Communi- cation modules	Keypad Keypad XT	LECOM -AB, -LI	LECOM-A	INTERBUS, INTERBUS Loop	PROFIBUS- DP	CAN	CanOpen / DeviceNet	LON
Function modules	Best.-Nr.	E82ZBC EMZ9371BC	2102 V001, V002 V003	2102 V0x4	2111 2112 2113	2133	2171 2172	2175	2141
Standard I/O	E82ZAFSCxxx	✓	✓	✓	✓	✓	✓	✓	✓
Application I/O	E82ZAFACxxx	✓	○	✓	○	○	○	○	○
INTERBUS	E82ZAFICxxx	✓	✓	✓	☒	☒	☒	☒	☒
PROFIBUS- DP	E82ZAFPCxxx	✓	✓	✓	☒	☒	☒	☒	☒
LECOM-B (RS485)	E82ZAFLCxxx	✓	✓	✓	☒	☒	☒	☒	☒
System bus (CAN)	E82ZAFCC0xx	✓	✓	✓	✓	✓	✓	✓	✓
System bus I/O	E82ZAFCC2xx	✓	✓	✓	✓	✓	✓	✓	✓
ASI	E82ZAFFCxxx	✓	✓	✓	☒	☒	☒	☒	☒

- ✓ Combination possible
- Combination possible; AIF module must have an external supply
- ☒ Combination not possible

All communication modules can be combined with the 9300 vector range of drives and with the DrivePLC. Function modules (with screw terminal) can be used in conjunction with the 8200 motec and starttec.

The keypad XT and Global Drive Control easy (GDC easy) PC software, which simplify and speed up the operation of the inverter by means of a simple menu structure and assisted dialogue boxes, are available for parameterisation and diagnostics.

Automation components

Bus-compatible displays (HMI) which can be integrated into the control cabinet are available in various sizes for the visualisation of inverter parameters and process data. The Drive PLC is a freely programmable PLC (EN 61131-3) which can be used in conjunction with the frequency inverter to implement distributed control tasks. Extension boards can be used to expand the Drive PLC

input and output terminals. The range is completed by bus-compatible, freely programmable I/O terminals, which are used for interfacing sensors and actuators with the bus.

The 8200 vector in networked systems

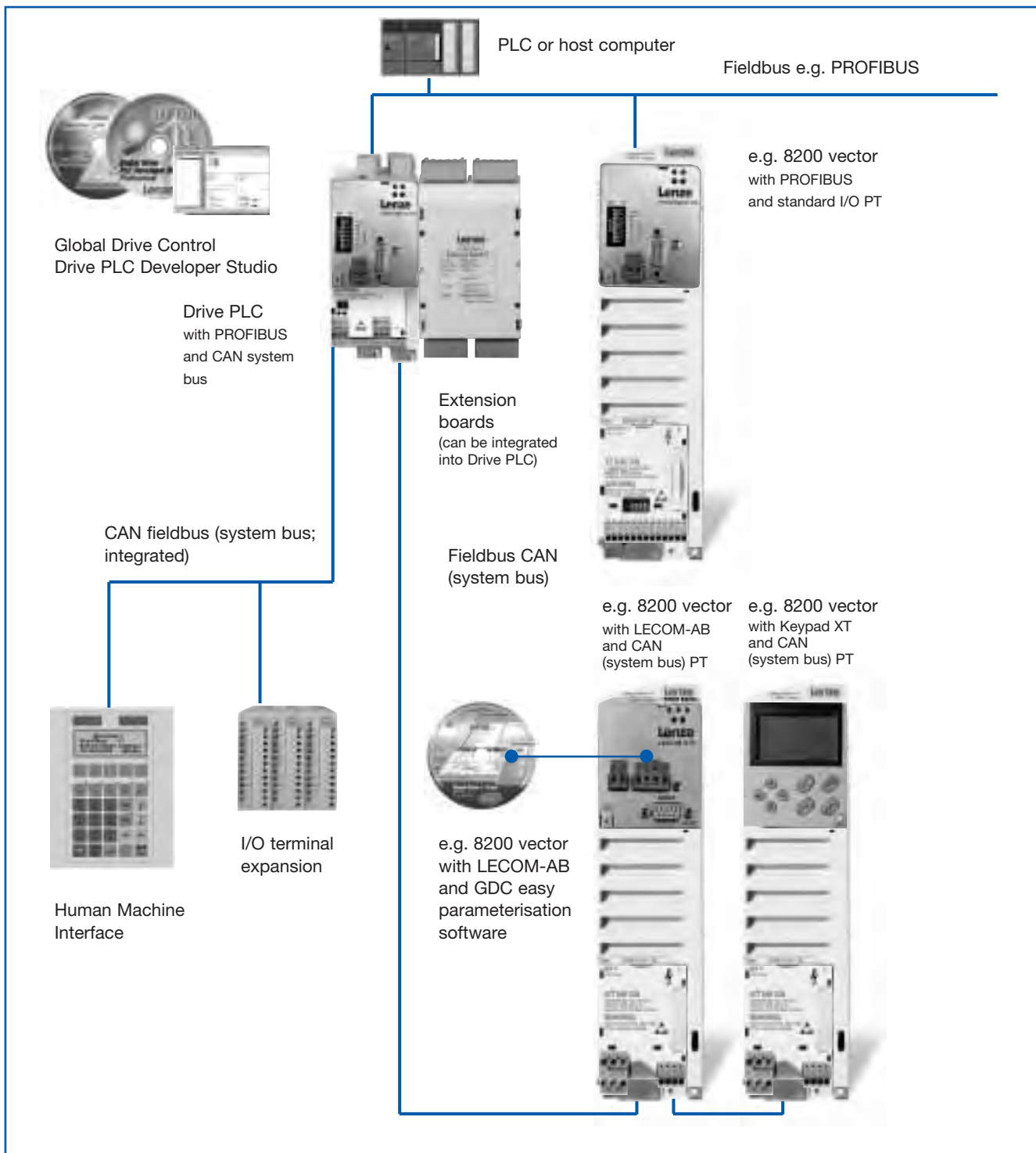

The following combinations are possible in order to be able to implement the various requirements:

Fieldbus combination

– During open-loop and closed-loop control via digital and analog I/O

– Whilst the drive controller is being parameterised/ diagnosed

– With a single drive controller whilst Another is being parameterised by the same host controller => remote parameterisation

1.

Networking via fieldbus and open-loop/closed-loop control with digital and analog inputs and outputs

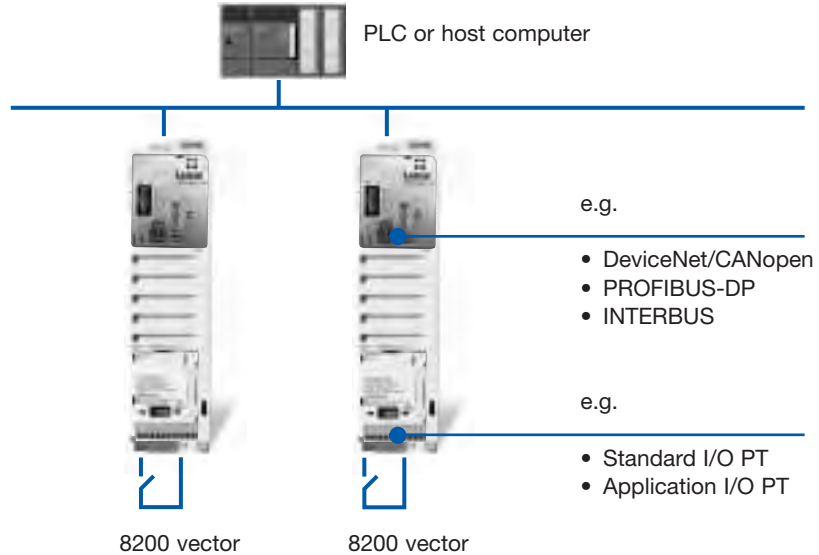

2.

Parameterisation and diagnostics during fieldbus operation

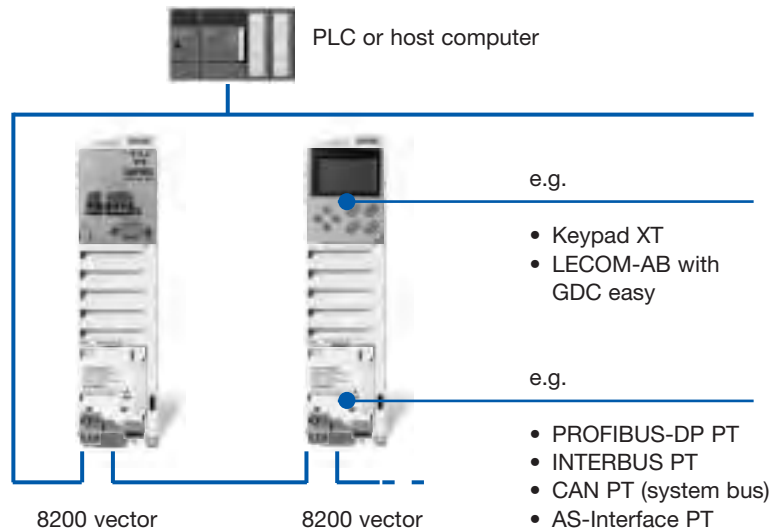

3.

Remote parameterisation via fieldbus

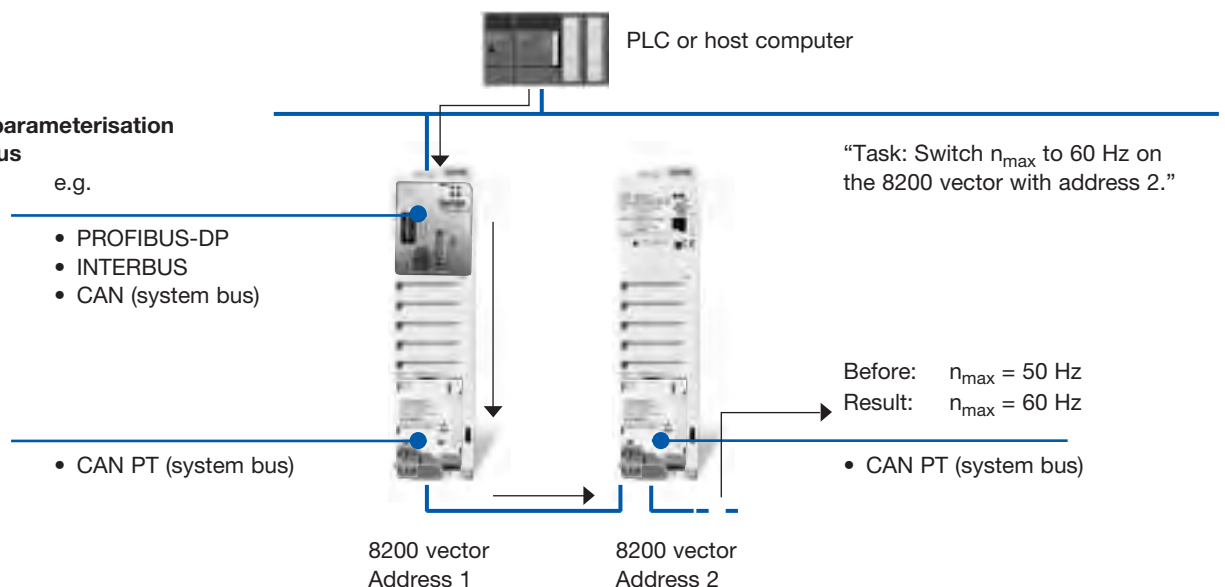

Keypad XT – Operating module

Keypad XT	Order ref.	EMZ9371BC
Keypad	Order ref.	E82ZBC

The keypad XT is available for visualising operating parameters and parameter settings for the inverter. 8 keys and a text display provide quick and easy access to the inverter parameters via the transparent menu structure. The keypad XT is also used for the purposes of status display and error diagnostics. In addition, its built-in memory can be used to transfer parameters to other inverters. The keypad XT can also be used on devices

from the 9300 vector, 9300 servo and Drive PLC ranges, as well as on 8200 motec motor inverters (via hand terminals). The keypad is suitable for installation in the control cabinet. The differences between the keypad XT and keypad are listed in the “Features” overview.

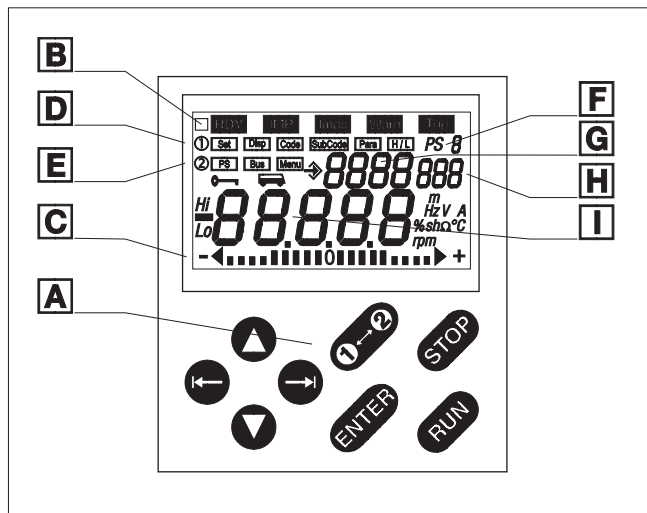
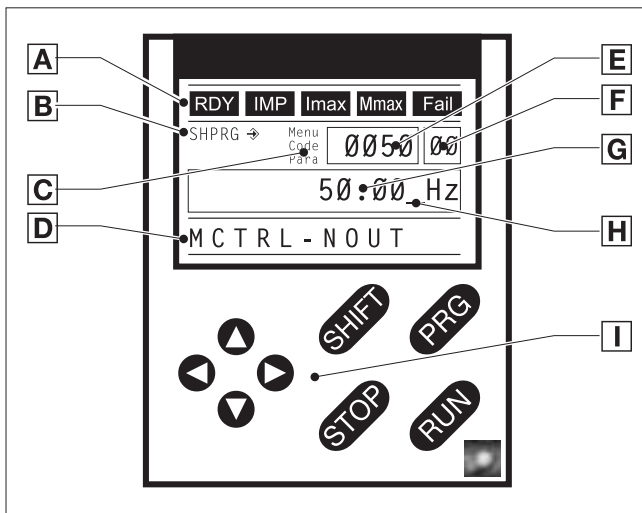

Keypad XT

- A Status displays
- B Transfer parameters
- C Active level
- D Help text
- E Menu or code number
- F Menu or subcode number
- G Parameters
- H Cursor
- I Function keys

Keypad

- A Function keys
- B Status displays
- C Bar graph display
- D Function bar 1
- E Function bar 2
- F Parameters for change
- G Code number
- H Subcode number
- I Parameter value with unit

Dimensions of control cabinet assembly kit (Keypad only)

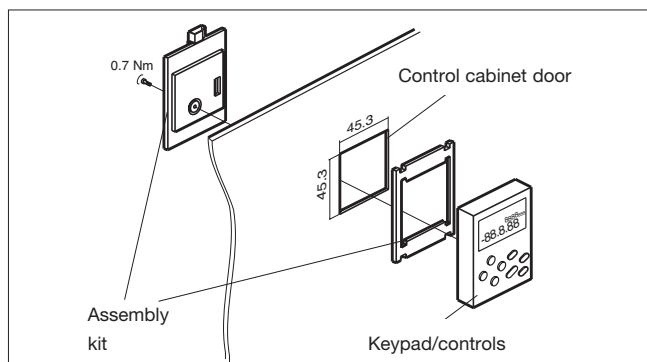

Product features

	Keypad XT	Keypad
Plain text display	Yes	No
Menu structure	Yes	No
Predefined basic configurations	Yes	No
Text display	Yes	Yes
Control keys	8	8
Non-volatile storage for parameter transfer	Yes	Yes
Password protection	Yes	Yes
Control cabinet installation	No	Yes
Configurable menu (user menu)	Yes	Yes
Application-specific menus	Yes	No
“Quick start-up” menu	Yes	No
Can be used with	8200 vector, 8200 motec, Drive PLC, 9300 vector, 9300 servo	8200 vector, 8200 motec, starttec
Hand terminal	Yes	Yes
Degree of protection	IP 20	IP 55



To facilitate handling, a connecting cable can be used to plug the keypad into a hand-held device so that it can be used as a hand terminal.

Hand terminal
(handheld keypad and connecting cable)

Selection	Order ref.
Hand terminal (complete with keypad XT, IP 20)	E82ZBBXC
Hand terminal (complete with keypad, IP 55)	E82ZBB
Control cabinet installation kit ²⁾	E82ZBHT
2.5 m connecting cable ¹⁾	E82ZWL025
5 m connecting cable ¹⁾	E82ZWL050
10 m connecting cable ¹⁾	E82ZWL100

¹⁾ The connecting cable is required to connect the hand terminal or control cabinet installation kit with the 8200 vector.

²⁾ The additional control cabinet installation kit is required if the keypad (only E82ZBC version) is to be installed in the door of the control cabinet. (keypad in IP 55 protection)

Global Drive Control – GDC easy parameterisation software

GDC easy	Order ref.	ESP-GDC2-E
GDC	Order ref.	ESP-GDC2

The Global Drive Control easy software tool is an easy to understand and convenient tool for the operation, parameter setting and diagnostics of 8200/8200 vector range frequency inverters.

Essential features include:

- Dialogue-assisted operation
- Monitor window for displaying operating parameters and diagnostics
- Extensive help functions
- Loading and saving parameter files from and to the inverter
- Saving and printing out parameter settings as code lists

Global Drive Control can for example be downloaded from the Internet at Lenze website.

It offers the following advantages:

- Easy as possible, intuitive operation
- Even suitable for beginners
(no program knowledge required)

Global Drive Control – GDC easy parameterisation software



Global Drive Control incorporates all of the functions described here. You can also use the Global Drive Control **easy** software if you simply wish to set the parameters of the frequency inverter:

Product feature	GDC easy	GDC
Quick start-up:		
8200	✓	✓
8200 vector/motec	✓	✓
9300 vector		✓
9300 servo		✓
Technology functions ¹⁾		✓
Code lists	✓	✓
Monitor windows	✓	✓
Function block editor		✓
Oscilloscope functions ²⁾		✓
Order number:	ESP-GDC2-E	ESP-GDC2

¹⁾ For 9300 servo product series
²⁾ For 9300 product series

Systems requirements of GDC (easy)

Hardware:

- IBM-AT or compatible PC
- CPU
 - Pentium 90 or higher
- RAM
 - 64 MB
- At least 120 MB of free hard disk space
- Super VGA graphic card
- CD-ROM drive
- A free serial interface for RS232 or a free parallel interface for the system bus adapter (CAN)

Software:
 Windows 95/98/Me/NT 4.0/2000/XP

Standard I/O PT

Standard I/O PT	Order ref.	E82ZAFSC010
Standard I/O	Order ref.	E82ZAFSC

The function module provides the inverter with digital input and outputs for standard applications.

A plug-in spring-clamp terminal (PT version) provides easy and quick wiring of cable cross-sections up to 1.5 mm² without wire end ferrule. Due to the plugged-on spring-clamp terminal strip, the function module juts out approx. 13 mm of the front panel of the frequency inverter. The module is also available in a basic version without plug-in terminal.

Available input and output terminals

Analog IN	Analog OUT	Digital IN	Digital OUT
1	1	4 ¹⁾	1

¹⁾ Can include 1 frequency input (0...10 kHz, single-track or two-track via E1 and E2, 8200 vector 82xVxxxKxBxxxXXxx2x or later)



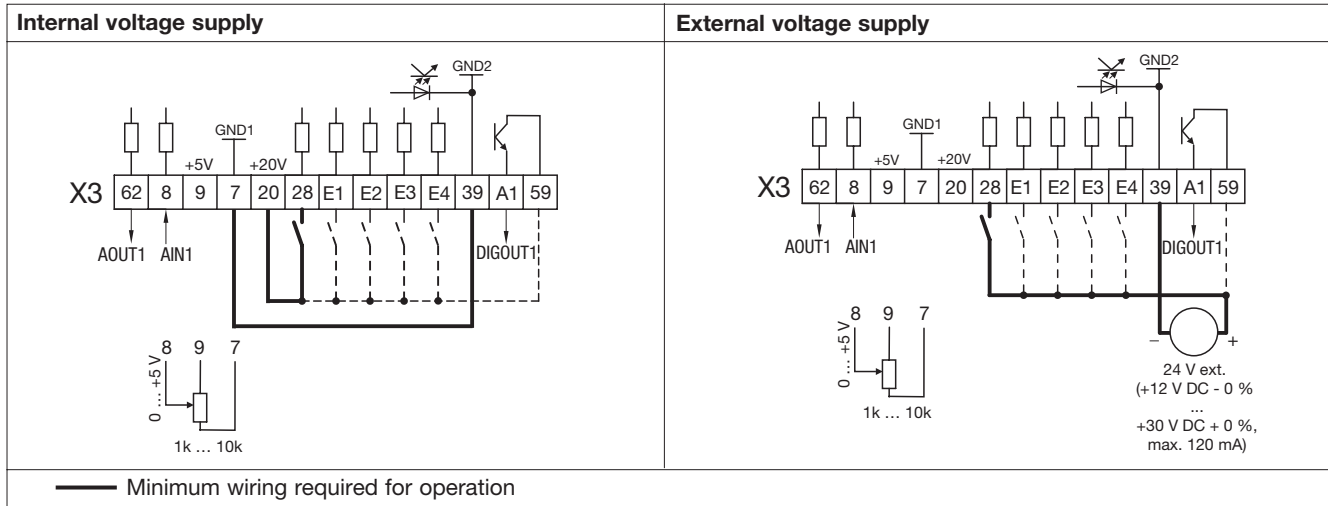

Terminal assignment



Standard I/O PT

X3	Signal type	Function (bold = Lenze setting)	Level	Technical data		
8	Analog input	Actual or setpoint value input	0 ... +5 V 0 ... +10 V -10 V... +10 V 0 ... +20 mA +4 ... +20 mA +4 ... +20 mA (monitored for open circuit)	Resolution: 10-bit Linearity error: ±0.5% Temp. sensitivity: 0.3% (0 ... +60°C) Input resistance – Voltage signal: > 50 kΩ – Current signal: 250 Ω		
62	Analog output	Output frequency	0... +10 V	Resolution: 10-bit Linearity error: ±0.5% Temp. sensitivity: 0.3% (0 ... +60°C) Load capacity: max. 2 mA		
28		Controller inhibit	1 = START	Input resistance: 3.3 kΩ 1 = HIGH (+12...+30 V) 0 = LOW (0...+3 V) (PLC level, HTL)		
E1 1)	Digital inputs	Activation of fixed frequencies (JOG)			E1	E2
E2 1)		JOG1 = 20 Hz	JOG1		1	0
		JOG2 = 30 Hz	JOG2		0	1
		JOG3 = 40 Hz	JOG3		1	1
E3		DC brake (DCB)	1 = DCB active			
E4	Reversal of direction of rotation Clock./counter-clock. rotation (CW/CCW)		E4			
			CW	0		
			CCW	1		
A1	Digital output	Ready for operation	0/+20 V with internal DC 0/+24 V with external DC		Load capacity: 10 mA 50 mA	
9	–	Internal, stabilised DC supply for setpoint value potentiometer	+5.2 V (reference: X3/7)		Load capacity: max. 10 mA	
20	–	Internal DC supply for actuation of the digital inputs and outputs	+20 V ±10% (reference: X3/7)		Max. load capacity: ∑ I = 40 mA	
59	–	DC supply for A1	+20 V (internal, bridge to X3/20) +24 V (external)			
7	–	GND1, reference potential for analog signals	–		Isolated to GND2	
39	–	GND2, reference potential for digital signals	–		Isolated to GND1	

¹⁾ Optional 0...10 kHz single-track (via E1) or 0...1 kHz two-track frequency input (via E1 and E2) 8200 vector E82xVxxxKxxxxXXxx2x or later

Electrical connection	Push-on terminal strip with spring-clamp connection		
Connection options		Rigid: 1.5 mm ² (AWG 16)	
		Flexible:	
		1.5 mm ² (AWG 16)	without ferrules
		1.5 mm ² (AWG 16)	with ferrules without plastic sleeve
	0.5 mm ² (AWG 20)	with ferrules with plastic sleeve	

Application I/O PT

Application I/O PT	Order ref.	E82ZAFAC010
Application I/O	Order ref.	E82ZAFAC

The function module provides the inverter with digital input and outputs for complex applications. A plug-in spring-clamp terminal (PT version) enables cable cross-sections of up to 1.5 mm² to be connected quickly and easily without the need for ferrules. Due to the plugged-on spring-clamp terminal strip, the function module juts out approx. 13 mm of the front panel of the frequency inverter. The module is also available in a basic version without plug-in terminal.

Available input and output terminals

Analog IN	Analog OUT	Digital IN	Digital OUT	Frequenz OUT
2	2	6 ¹⁾	2	1

¹⁾ Can include 1 frequency input (0...102.4 kHz, single-track or two-track)

Terminal assignment

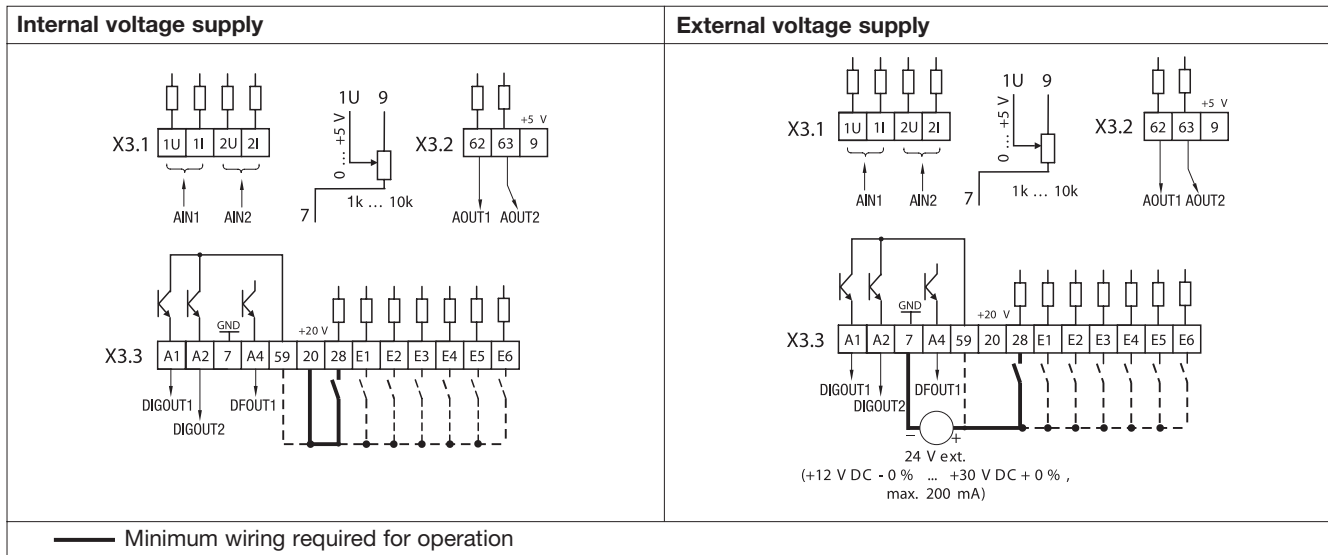





3



Application I/O PT

X3	Signal type	Function (bold = Lenze setting)	Level	Technical data		
1U/ 2U	Analog inputs	Actual or setpoint value inputs (master reference voltage)	0 ... +5 V 0 ... +10 V -10 V... +10 V	Resolution: 10-bit Linearity error: ±0.5%		
1I/2I		Actual or setpoint value inputs (master reference current)	0 ... +20 mA +4 ... +20 mA +4 ... +20 mA (monitored for open circuit)	Input resistance – Voltage signal: > 50 kΩ – Current signal: 250 Ω		
62	Analog outputs	Output frequency	0... +10 V 0 ... +20 mA +4 ... +20 mA	Resolution: 10-bit Linearity error: ±0.5% Temp. sensitivity: 0.6% (0 ... +60°C)		
63		Motor current		Load capacity: (0...+10 V): max. 2 mA RL (0/4...20 mA) ≤ 500 Ω		
28		Controller inhibit	1 = START			
E1 1)	Digital inputs	Activation of fixed frequencies (JOG) JOG1 = 20 Hz JOG2 = 30 Hz JOG3 = 40 Hz		E1	E2	Input resistance: 3.2 kΩ 1 = HIGH (+12...+30 V) 0 = LOW (0...+3 V) (PLC level, HTL)
E2 1)			JOG1	1	0	
			JOG2	0	1	
			JOG3	1	1	
E3		DC brake (DCB)	1 = DCB active			
E4		Reversal of direction of rotation Clock./counter-clock. rotation (CW/CCW)		E4		
			CW	0		
		CCW	1			
E5		Not pre-configured	–			
E6		Not pre-configured	–			
A1	Digital outputs	Ready for operation				
A2		Not pre-configured	0/+20 V with internal DC 0/+24 V with external DC			
A4	Frequency output	DC bus voltage	HIGH: +18 V... +24 V (HTL) LOW: 0 V		0.05 kHz...10 kHz Load capacity: max. 8 mA	
9	–	Internal, stabilised DC supply for setpoint value potentiometer	+5.2 V		Load capacity: max. 5 mA	
20	–	Internal DC supply for actuation of the digital inputs and outputs	+20 V ±10%		Load capacity: max. 60 mA	
59	–	DC supply for X3/A1 and X3/A2	+20 V (internal, bridge to X3/20) +24 V (external)			
7	–	GND, reference potential	–			

1) Optional 0...102.4 kHz frequency input, single-track or two-track

Electrical connection	Push-on terminal strip with spring-clamp connection	
Connection options		Rigid: 1.5 mm ² (AWG 16)
		Flexible:
		1.5 mm ² (AWG 16) without ferrules
		1.5 mm ² (AWG 16) with ferrules without plastic sleeve
		0.5 mm ² (AWG 20) with ferrules with plastic sleeve

Tip:

Lenze three-phase AC motors and Lenze geared motors can be supplied with the Lenze pulse encoder ITD21 (512/2048 increments, HTL output signals). This enables two-track rotational speed feedback (tracks A and B) to be set up for the application I/O function module.

CAN PT (system bus)

CAN PT (system bus)	Order ref.	E82ZAFCC010
CAN (system bus)	Order ref.	E82ZAFCC

The CAN (system bus) function module can be used to interface the 8200 vector with the CAN (Controller Area Network) serial communication system. Plug-in spring-clamp terminals enable cable cross-sections of up to 1.5 mm² to be connected quickly and easily without the need for ferrules. Due to the plugged-on spring-clamp terminal strip, the function module juts out approx. 15 mm of the front panel of the frequency inverter. For the purposes of simple diagnostics, dual screw terminals can be used to interrupt communication with the frequency inverter without affecting the bus operation of other devices. The module is also available in a basic version without plug-in terminal.

The function module enables the 8200 vector to perform additional functions, including:

- Parameter preselection/remote parameter setting
- Data transfer between inverters
- Connection to external control systems (e.g. drive PLC) and host systems
- Optional connection to
 - distributed terminal extensions (see also page 3-42)
 - keypads

Terminal assignment

X3.1/	Name	Function
7	GND1	Reference potential 1
LO	CAN-LOW	System bus LOW (data cable)
HI	CAN-HIGH	System bus HIGH (data cable)
X3.2/		
7	GND1	Reference potential 1
39	GND2	Reference potential 2 for controller inhibit (CINH) at X3.2/28
28	CINH	Controller inhibit <ul style="list-style-type: none"> • Start = HIGH (+12 V...+30 V) • Stop = LOW (0 V ... +3 V)
20		DC voltage source for internal supply for controller inhibit (CINH) +20 V (reference: GND1)

Supply: Controller inhibit terminal (X3/28) via internal voltage supply

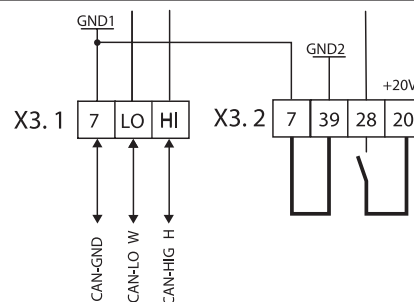

Supply: Controller inhibit terminal (X3/28) via external voltage supply

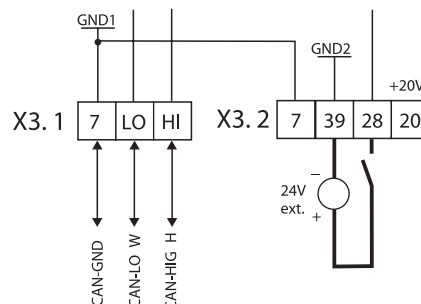





— Minimum wiring required for operation



CAN PT (system bus)

General data and application conditions

Communication medium	DIN ISO 11898				
Communication profile	Similar to CANopen (CiA DS301)				
Network topology	Line (terminated at both ends with 120 Ω)				
System bus device	Master or slave				
Max. number of devices	63				
Baud rate [kBit/s]	20	50	125	250	500
Max. bus length [m] ³⁾	3910	1510	590	250	80
Number of logical process data channels	2				
Number of logical parameter data channels	2				
Electrical connection	Push-on terminal strips with spring-clamp connection and dual screw connection				
Connection options		Rigid: 1.5 mm ² (AWG 16)			
	Flexible:				
		1.5 mm ² (AWG 16) without ferrules			
		1.5 mm ² (AWG 16) with ferrules without plastic sleeve			
	0.5 mm ² (AWG 20) with ferrules with plastic sleeve ¹⁾				
	1.5 mm ² (AWG 16) with ferrules with plastic sleeve ²⁾				
DC supply to the function module	Internal				
Insulation voltage to reference earth/PE	50 V AC				
Ambient temperature	Operation: -20 ... +60°C Transport: -25 ... +70°C Storage: -25 ... +60°C				
Climatic conditions	Class 3K3 to EN 50178 (without condensation, average relative humidity 85%)				

¹⁾ Spring-clamp connection

²⁾ Dual screw connection

³⁾ You should be aware of the additional effect of the number of devices and the cable cross-section used on the maximum bus cable lengths.

Note:

Two bus terminating resistors (120 Ω) are included in the scope of supply.

Wiring notes

We recommend the following signal cable:

System bus cable specification	Total length up to 300 m	Total length up to 1000 m
Cable type	LIYCY 2 x 2 x 0.5 mm ² (shielded twisted pairs)	CYPIMF 2 x 2 x 0.5 mm ² (shielded twisted pairs)
Cable resistance	≤ 40 Ω/km	≤ 40 Ω/km
Capacitance per unit length	≤ 130 nF/km	≤ 60 nF/km
Connection	Pair 1 (white/brown): CAN-LOW and CAN-HIGH Pair 2 (green/yellow): CAN-GND	

CAN I/O PT (system bus)

CAN I/O PT (system bus)	Order ref.	E82ZAFCC210
CAN I/O	Order ref.	E82ZAFCC200

The CAN (system bus) function module can be used to interface the 8200 vector with the CAN (Controller Area Network) serial communication system. Plug-in spring-clamp terminals enable cable cross-sections of up to 1.5 mm² to be connected quickly and easily without the need for ferrules. Due to the plugged-on spring-clamp terminal strip, the function module juts out approx. 15 mm of the front panel of the frequency inverter. The module has two freely programmable digital inputs. They can be used to activate the controller inhibit and two additional freely selectable signals via a digital signal. The node address and the baud rate can also be preselected easily using DIP switches. For the purposes of simple diagnostics, dual screw terminals can be used to interrupt communication

with the frequency inverter without affecting the bus operation of other devices. The module is also available in a basic version without plug-in terminal.

The function module enables the 8200 vector to perform additional functions, including:

- Parameter preselection/remote parameter setting
- Data transfer between inverters
- Connection to external control systems (e.g. drive PLC) and host systems
- Optional connection to – distributed terminal extensions (see also page 3-42) – keypads

X3.1/	Name	Function	Level
7	GND1	Reference potential 1	
LO	CAN-LOW	System bus LOW (data cable)	
HI	CAN-HIGH	System bus HIGH (data cable)	
X3.2/			
E1	Digital inputs	User-defined	0= LOW (0 ... +3 V)
E2			1= HIGH (+12 ... +30 V) (reference: GND1)
X3.3/			
7	GND1	Reference potential 1	
39	GND2	Reference potential 2 for controller inhibit (CINH) at X3.3/28	
28	CINH	Controller inhibit	<ul style="list-style-type: none"> • Start = HIGH (+12 V...+30 V) • Stop = LOW (0 V ... +3 V)
20		DC voltage source for internal supply for controller inhibit (CINH)	+20 V (reference: GND1)

Supply via internal voltage source (X3.3/20):

- X3.3/28, controller inhibit (CINH)
- X3.2/E1 and X3.2/E2, digital inputs

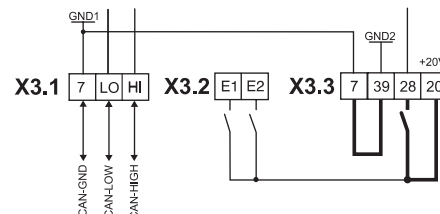

Supply via external voltage supply

- X3.3/28, controller inhibit (CINH)
- X3.2/E1 and X3.2/E2, digital inputs

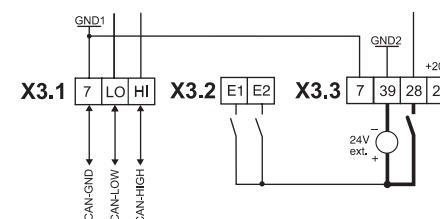







— Minimum wiring required for operation



CAN I/O PT (system bus)

General data and application conditions

Communication medium	DIN ISO 11898				
Communication profile	Similar to CANopen (CiA DS301)				
Network topology	Line (terminated at both ends with 120 Ω)				
System bus device	Master or slave				
Max. number of devices	63				
Baud rate [kBit/s]	20	50	125	250	500
Max. bus length [m] ³⁾	3910	1510	590	250	80
Number of logical process data channels	2				
Number of logical parameter data channels	2				
Electrical connection	Push-on terminal strips with spring-clamp connection and dual screw connection				
Connection options		Rigid: 1.5 mm ² (AWG 16)			
		Flexible:			
		1.5 mm ² (AWG 16) without ferrules			
		1.5 mm ² (AWG 16) with ferrules without plastic sleeve			
		0.5 mm ² (AWG 20) with ferrules with plastic sleeve ¹⁾			
		1.5 mm ² (AWG 16) with ferrules with plastic sleeve ²⁾			
DC supply to the function module	Internal				
Insulation voltage to reference earth/PE	50 V AC				
Ambient temperature	Operation: -20 ... +60°C Transport: -25 ... +70°C Storage: -25 ... +60°C				
Climatic conditions	Class 3K3 to EN 50178 (without condensation, average relative humidity 85%)				

¹⁾ Spring-clamp connection

²⁾ Dual screw connection

³⁾ You should be aware of the additional effect of the number of devices and the cable cross-section used on the maximum bus cable lengths.

Note:

Two bus terminating resistors (120 Ω) are included in the scope of supply.

Wiring notes

We recommend the following signal cable:

System bus cable specification	Total length up to 300 m	Total length up to 1000 m
Cable type	LIYCY 2 x 2 x 0.5 mm ² (shielded twisted pairs)	CYPIMF 2 x 2 x 0.5 mm ² (shielded twisted pairs)
Cable resistance	≤ 40 Ω/km	≤ 40 Ω/km
Capacitance per unit length	≤ 130 nF/km	≤ 60 nF/km
Connection	Pair 1 (white/brown): CAN-LOW and CAN-HIGH Pair 2 (green/yellow): CAN-GND	

PROFIBUS-DP PT

PROFIBUS-DP PT	Order ref.	E82ZAFPC010
PROFIBUS-DP	Order ref.	E82ZAFPC

The PROFIBUS-DP function module is a slave connection module with the PROFIBUS-DP communication profile. It is used for networking between the host and the frequency inverter. Plug-in spring-clamp terminals enable cable cross-sections of up to 1.5 mm² to be connected quickly and easily without the need for ferrules. Due to the plugged-on spring-clamp terminal strip, the

function module juts approx. 15 mm of the front panel of the frequency inverter. For the purposes of simple diagnostics, dual screw terminals can be used to interrupt communication with the frequency inverter without affecting the bus operation of other devices. The module is also available in a basic version without plug-in terminal.



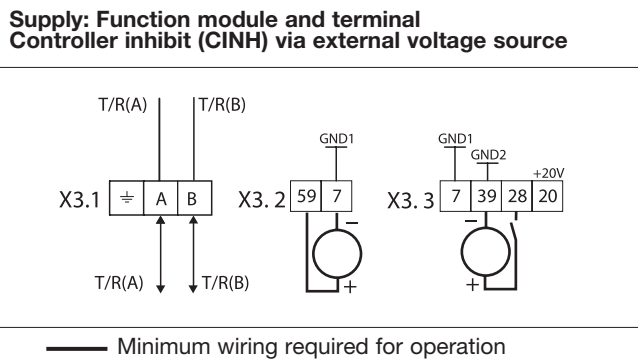
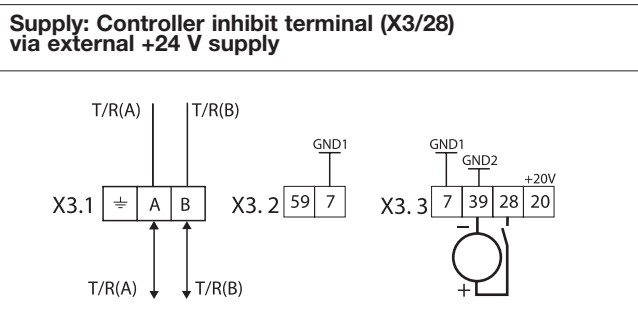
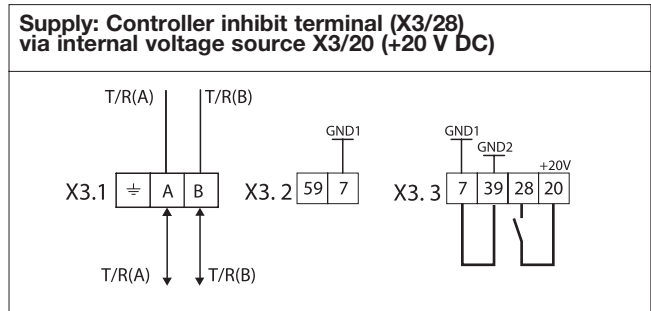

Terminal assignment

X3.1/	Name	Function
y	PES	Additional HF screen termination
A	T/R(A)	RS485 data cable A
B	T/R(B)	RS485 data cable B
X3.2/		
7	GND1	Reference potential for X3.3/20
59		External DC supply for function module U(ext.) = +24 V DC ±10% (reference: GND1)
X3.3/		
7	GND1	Reference potential for X3.3/20
39	GND2	Reference potential for controller inhibit (CINH) at X3.3/28
28	CINH	Controller inhibit <ul style="list-style-type: none"> • Start = HIGH (+12 V ... +30 V) • Stop = LOW (0 ... +3 V)
20		DC voltage source for internal supply for controller inhibit (CINH) +20 V (reference: GND1)
DIP switch	DIP switch = ON	Integrated bus terminating resistor active
	DIP switch = OFF	Integrated bus terminating resistor inactive



PROFIBUS-DP PT

General data and application conditions

Communication medium	RS485
Communication profile	PROFIBUS-DP (DIN 19245 Part 1 and Part 3)
Drive profile	DRIVECOM profile "Drive Technology 20" or Lenze device control
Baud rate [kBit/s]	9.6... 12000 (automatic detection)
PROFIBUS-DP device	Slave
Network topology	Without repeater: line With repeaters: line or tree
Process data words (PCD) (16 bits)	1 word ... 10 words
DP user data length	Parameter channel (4 words) + process data words
Number of devices	Standard: 32 (= 1 bus segment) including host system With repeaters: 128 including host system and repeaters
Max. cable length per bus segment	1000 m (depending on baud rate and cable type used)
Communication time	<ul style="list-style-type: none"> • Sum of scan time and processing time in the fieldbus devices. The times are independent of one another. • Processing time in the controller: <ul style="list-style-type: none"> - Parameter data and process data are independent of each other - Parameter data: approx. 30 ms +20 ms tolerance - Process data: approx. 3 ms +2 ms tolerance
Electrical connection	Push-on terminal strips with spring-clamp connection and dual screw connection
Connection options	 Rigid: 1.5 mm ² (AWG 16) Flexible:  1.5 mm ² (AWG 16) without ferrules  1.5 mm ² (AWG 16) with ferrules without plastic sleeve  0.5 mm ² (AWG 20) with ferrules with plastic sleeve ¹⁾  1.5 mm ² (AWG 16) with ferrules with plastic sleeve ²⁾
DC supply for function module	<ul style="list-style-type: none"> • Internal • External, only required for <ul style="list-style-type: none"> - bus devices which are to be disconnected from the mains, but communication with the master is to be maintained - bus devices with activated bus terminating resistor, which are to be disconnected from the mains, but the bus system is to remain active - supply via separate mains supply - +24 V DC ± 10%, max. 80 mA per function module
Insulation voltage to reference earth/PE	50 V AC
Ambient temperature	Operation: -20 ... +60°C Transport: -25 ... +70°C Storage: -25 ... +60°C
Climatic conditions	Class 3K3 to EN 50178 (without condensation, average relative humidity 85%)

¹⁾ Spring-clamp connection

²⁾ Dual screw connection

Note:

- Two LEDs are located on the function module to indicate the communication status.
- A configuration diskette for PROFIBUS-DP containing the description files for the devices (EDS files) is included in the scope of supply.

Important:

The internal or external DC supply to the controller inhibit terminal (X3/28) is provided **independently** of the internal or external DC supply to the function module.

Tip:

The external DC supply to the function module is provided via terminals X3/59 and X3/7. The connection diagrams above indicate the internal DC supply to the function module as an alternative option.

INTERBUS PT

INTERBUS PT	Order ref.	E82ZAFIC010
INTERBUS	Order ref.	E82ZAFIC

The INTERBUS function module is used to interface the frequency inverter directly with the remote bus. The DRIVE-COM profile 20 is supported for this connection. DIP switches are used to set the process data volume, PCP communication and the last physical bus device. Plug-in spring-clamp terminals enable cable cross-sections of up to

1.5 mm² to be connected quickly and easily without the need for ferrules.

Due to the plugged-on spring-clamp terminal strip, the function module juts approx. 15 mm of the front panel of the frequency inverter. The module is also available in a basic version without plug-in terminal.

Terminal assignment

X3.1/	Name	Function
59		External DC supply for function module (+ 24 V DC ± 10%, looping through of external supply for function module possible)
7	GND1	Reference potential for X3.3/20
X3.2/		
7	GND1	Reference potential for X3.3/20
39	GND2	Reference potential for controller inhibit (CINH) at X3.3/28
X3.3/		
A	/DO1	RS485 data cable (incoming)
B	DO1	
C	/DI1	
D	/DI1	

X3.3/	Name	Function
E	GND3	Reference potential for incoming data cable
F	/DO2	RS485 data cable (outgoing)
G	DO2	
H	/DI2	
J	DI2	
K	GND1	Reference potential for outgoing data cable
y	PES	Additional HF shield termination
28	CINH	Controller inhibit <ul style="list-style-type: none"> • Start = HIGH (+12 V ... +30 V) • Stop = LOW (0 ... +3 V)
20		DC voltage source for internal +20 V (reference: GND1)

Supply: Controller inhibit terminal (X3/28) via internal voltage supply X3/20

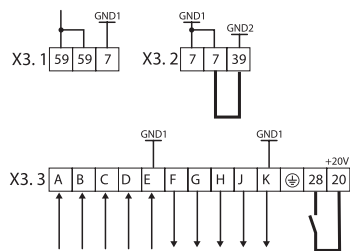

Supply: Function module and terminal "controller inhibit" (X3/28) via external voltage

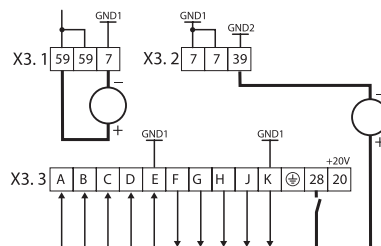

Supply for terminal controller inhibit (CINH) via external voltage source

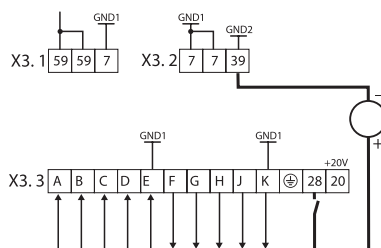





— Minimum wiring required for operation



INTERBUS PT

General data and application conditions

Communication medium	RS485
Drive profile	DRIVECOM profile "Drive Technology 20" or Lenze device control
Baud rate [kBit/s]	500
INTERBUS device	Slave
Network topology	Ring (go and return lines in the same bus cable)
Process data words (PCD) (16 bits)	1 Word ... 6 words
Parameter data words (PCP) (16 bits)	0/1 word
INTERBUS code (ID code)	Decimal: 227 or 3 (without PCP); hex: E3 or 3 (without PCP)
Max. PDU length	64 bytes
Supported PCP services	Initiate, Abort, Status, Identify, Get-OV-Long, Read, Write
Number of devices	Depends on the host system (I/O range), max. 63
Max. distance between 2 devices	400 m
Communication time	<ul style="list-style-type: none"> • Sum of scan time and processing time in the fieldbus devices. The times are independent of one another. • Processing time in the controller: <ul style="list-style-type: none"> – Parameter data and process data are independent of each other – Parameter data (PCP): approx. 30 ms +20 ms tolerance – Process data: approx. 3 ms +2 ms tolerance
Electrical connection	Push-on terminal strip with spring-clamp connection
Connection options	 Rigid: 1.5 mm ² (AWG 16) Flexible:  1.5 mm ² (AWG 16) without ferrules  1.5 mm ² (AWG 16) with ferrules without plastic sleeve  0.5 mm ² (AWG 20) with ferrules with plastic sleeve
DC supply for function module	<ul style="list-style-type: none"> • Internal • External, <ul style="list-style-type: none"> – only required if the communication ring must not be interrupted by a bus device being switched off or failing – supply via separate mains supply – +24 V DC ± 10%, max. 90 mA per function module – X3/59 can be loaded with a maximum of 3A when the supply voltage is looped through to other bus devices
Insulation voltage to reference earth/PE	50 V AC
Ambient temperature	Operation: –20 ... +60°C Transport: –25 ... +70°C Storage: –25 ... +60°C
Climatic conditions	Class 3K3 to EN 50178 (without condensation, average relative humidity 85%)

Note:

Two LEDs are located on the function module to indicate the communication status.

Important:

The internal or external DC supply to the controller inhibit terminal (X3/28) is provided **independently** of the internal or external DC supply to the function module.

Tip:

The external DC supply to the function module is provided via terminals X3/59 and X3/7 (see connection diagrams above).

LECOM-B PT (RS485)

LECOM-B PT (RS485)	Order ref.	E82ZAFLC010
LECOM-B (RS485)	Order ref.	E82ZAFLC

Communication via the function module LECOM-B (RS485) uses the Lenze protocol LECOM. This protocol is open to the user. Components which support this protocol area available for various systems (e.g. Simatic S5). Plug-in spring-clamp terminals enable cable cross-sections of up to 1.5 mm² to be connected quickly and easily without the need for ferrules. Due to the plugged-on spring-clamp terminal strip, the function module juts out approx. 15 mm

of the front panel of the frequency inverter. For the purposes of simple diagnostics, dual screw terminals can be used to interrupt communication with the frequency inverter without affecting the bus operation of other devices. The module is also available in a basic version without plug-in terminal.

Terminal assignment

X3.1/	Name	Function
y	PES	Additional HF screen termination
A	T/R(A)	RS485 data cable A
B	T/R(B)	RS485 data cable B
X3.2/		
7	GND1	Reference potential for X3.3/20
59		External DC supply for function module U(ext.) = +24 V DC ±10% (reference: GND1)
X3.3/		
7	GND1	Reference potential for X3.3/20
39	GND2	Reference potential for controller inhibit (CINH) at X3.3/28
28	CINH	Controller inhibit <ul style="list-style-type: none"> • Start = HIGH (+12 V ... +30 V) • Stop = LOW (0 ... +3 V)
20		DC voltage source for internal supply for controller inhibit (CINH) +20 V (reference: GND1)

Supply: Controller inhibit terminal (X3/28) via internal voltage source X3/20 (+20 V DC)

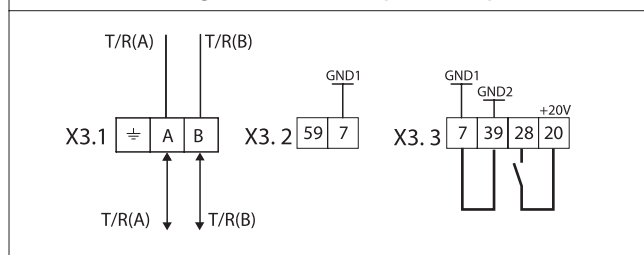

Supply: Controller inhibit terminal (X3/28) via external +24 V supply

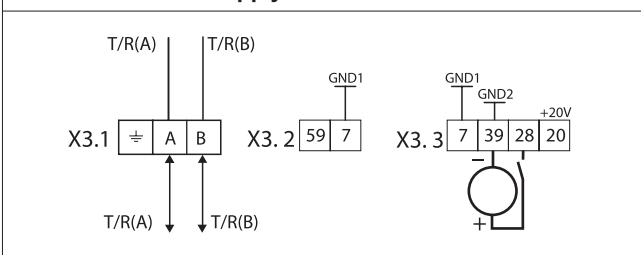



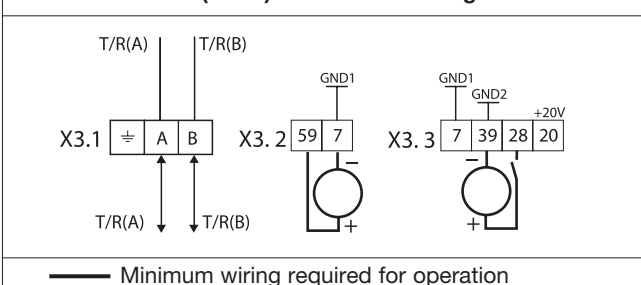

Supply: Function module and terminal Controller inhibit (CINH) via external voltage source



LECOM-B PT RS485)

General data and application conditions

Communication medium	RS485 (LECOM-B)
Communication protocol	LECOM A/B V2.0
Transfer character format	7E1: 7-bit ASCII, 1 stop bit, 1 start bit, 1 parity bit (even)
Baud rate [bit/s]	1200, 2400, 4800, 9600, 19200, 38400, 57600
LECOM-B device	Slave
Network topology	Without repeater: line With repeaters: line or tree
Process data words (PCD) (16 bits)	2 words
Max. number of devices	32 (= 1 bus segment) including host system With repeaters: 90 slaves
Max. cable length per bus segment	1000 m (depending on baud rate and cable type used)
Electrical connection	Screw terminals
Connection options	 Rigid: 1.5 mm ² (AWG 16) Flexible:  1.5 mm ² (AWG 16) without ferrules  1.5 mm ² (AWG 16) with ferrules without plastic sleeve  0.5 mm ² (AWG 20) with ferrules with plastic sleeve ¹⁾  1.5 mm ² (AWG 16) with ferrules with plastic sleeve ²⁾
DC supply for function module	<ul style="list-style-type: none"> • Internal • External, only required for <ul style="list-style-type: none"> – bus devices which are to be disconnected from the mains, but communication with the master is to be maintained – bus devices with activated bus terminating resistor, which are to be disconnected from the mains, but the bus system is to remain active – supply via separate mains supply – +24 V DC ± 10%, max. 70 mA per function module
Insulation voltage to reference earth/PE	50 V AC
Ambient temperature	Operation: –20 ... +60°C Transport: –25 ... +70°C Storage: –25 ... +60°C
Climatic conditions	Class 3K3 to EN 50178 (without condensation, average relative humidity 85%)

¹⁾ Spring-clamp connection
²⁾ Dual screw connection

Note:

Two LEDs are located on the function module to indicate the communication status.

Important:

The internal or external DC supply to the controller inhibit terminal (X3/28) is provided **independently** of the internal or external DC supply to the function module.

Tip:

The external DC supply to the function module is provided via terminals X3/59 and X3/7. The connection diagrams above indicate the internal DC supply to the function module as an alternative option.

AS-Interface PT

AS-Interface PT	Order ref.	E82ZAFFC010
AS-Interface	Order ref.	E82ZAFFC

The function module enables the 8200 vector to be controlled with digital control signals via the "AS-Interface" bus system. Plug-in spring-clamp terminals enable cable cross-sections of up to 1.5 mm² to be connected quickly and easily without the need for ferrules. Due to the plugged-on spring-clamp terminal strip, the function module juts out approx. 15 mm of the front panel of the frequency inverter. For the purposes of simple diagnostics, dual screw terminals can be used to interrupt communication with the frequency inverter without affecting the bus operation of other devices. The module is also available in a basic version without plug-in terminal. The "AS-Interface" (AS-i) bus system has established itself for use at the lowest field level, particularly for digital signal transfer.

It is designed for applications that do not necessarily require powerful fieldbus systems, but do nonetheless need to exploit the advantages of serial communication.

The advantages of this system are:

- Easy to use and to set up
- Less wiring required
- Easy to integrate into existing systems
- Cost reductions

3 Terminal assignment

X3.1/	Wire colour (IEC757)	Explanation
+	BN	Please refer to the information included in the description of the AS-i system about the electrical connection of peripheral devices
-	BU	

X3.2/		Explanation
7	GND1	Reference potential 1
20		+ 20 V internal for controller inhibit, reference: X3/7
28		Controller inhibit <ul style="list-style-type: none"> • Start = HIGH (+12 V...+ 30 V) • Stop = LOW (0...+3 V)
39	GND2	Reference potential for X3/28



Supply: Controller inhibit terminal (X3/28) via internal voltage supply

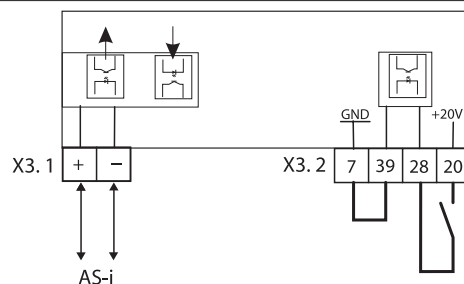



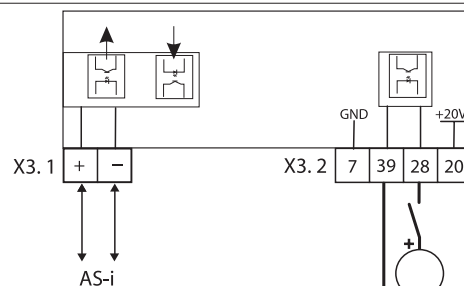

Supply: Controller inhibit terminal (X3/28) via external +24 V supply



— Minimum wiring required for operation

AS-Interface PT

General data and application conditions

Protocol/communication medium	AS-i
Network topology	Tree
Bus device	Slave
Max. number of nodes	31
Baud rate [kBit/s]	167
Scan time [ms]	5 ms (with 31 nodes)
Max. bus length [m]	100
Electrical connection (X3 terminal strip)	Screw terminals
Connection options (X3 terminal strip)	 Rigid: 1.5 mm ² (AWG 16)
	Flexible: <ul style="list-style-type: none">  1.5 mm² (AWG 16) without ferrules  1.5 mm² (AWG 16) with ferrules without plastic sleeve  0.5 mm² (AWG 20) with ferrules with plastic sleeve ¹⁾  1.5 mm² (AWG 16) with ferrules with plastic sleeve ²⁾
DC supply to the function module	via the bus
Isolation voltage to reference earth/PE	50 V AC
Ambient temperature	Operation: -20 ... +60°C Transport: -25 ... +70°C Storage: -25 ... +60°C
Climatic conditions	Class 3K3 to EN 50178 (without condensation, average relative humidity 85%)

¹⁾ Spring-clamp connection

²⁾ Dual screw connection

Note:

Two LEDs are located on the function module to indicate the communication status.

The following are available:

- 4 data bits to the 8200 vector (actuation)
The bits can be freely assigned in the 8200 vector.

Example:

- Bit 1 is assigned the function "Fixed setpoint value 1"
- Bit 2 is assigned the function "Fixed setpoint value 2"
- Bit 3 is assigned the function "DC brake"
- Bit 4 is assigned the function "Reversal of direction of rotation"

- 1 data bit from the 8200 vector (feedback)
This bit can be freely assigned in the 8200 vector, e.g. with a trip error message.
- 1 AS-i monitoring bit from the AS-i module

CAN/CANopen

CAN	Order ref.	EMF2171IB
CAN (addressing via DIP switches)	Order ref.	EMF2172IB
CANopen	Order ref.	EMF2175IB

The communication modules enable the inverter to support the CAN (2171/2172)/CANopen profile (2175). Modules 2171/2172 support parts of the CANopen communication profile and module 2175 supports the entire profile. Unlike module 2172, module 2171 has an additional DIP switch for presetting the network address and baud rate.

- The module EMF 2175IB can be switched over to DeviceNet via a DIP switch (see next page).
- Two LEDs are located on the communication modules to indicate the communication status.
- A configuration diskette for CANopen containing the description file for the devices (EDS file) is included in the scope of supply.

General data and application conditions

Communication medium	DIN ISO 11898						
Communication profile	CANopen						
DeviceNet device	Slave						
Network topology	Line (terminated at both ends with 120 Ω)						
Max. number of devices	63						
Baud rate [kBit/s]	10	20	50	125	250	500	1000
2171/2172: Max. bus length (m)¹⁾	–	–	1550	630	290	120	25
2175: Max. bus length (m)¹⁾	7450	3950	1550	630	290	120	25
Electrical connection	Screw-type terminals						
DC supply	<ul style="list-style-type: none"> • Internal • External <ul style="list-style-type: none"> – only required if a bus device is switched off or fails but communication with it is to be maintained – supply via separate mains supply – +24 V DC ± 10%, max. 100 mA per module 						
Insulation voltage to reference earth/PE	50 V AC						
Ambient temperature	Operation: 0 ... +55°C Transport: –25 ... +70°C Storage: –25 ... +60°C						
Climatic conditions	Class 3K3 to EN 50178 (without condensation, average relative humidity 85%)						

¹⁾ You should be aware of the additional effect of the number of devices and the cable cross-section used on the maximum bus cable lengths.



DeviceNet

DeviceNet	Order ref.	EMF2175IB
------------------	-------------------	------------------

The communication module enables the inverter to support the DeviceNet profile.

- The module can be switched over to CANopen via a DIP switch.
- The address and the baud rate can be adjusted via the DIP switch.
- Two LEDs are located on the communication module to indicate the communication status.
- A configuration diskette for DeviceNet containing description files for the devices (EDS files) is included in the scope of supply. The files can be downloaded from the Internet at Lenze website.

General data and application conditions

Communication medium	DIN ISO 11898		
Communication profile	DeviceNet		
DeviceNet device	Slave		
Network topology	Line (terminated at both ends with 120 Ω)		
Max. number of devices	63		
Baud rate [kBit/s]	125	250	500
Max. bus length (thin cable) [m]	100	100	100
Max. bus length (thick cable) [m]	500	250	100
Electrical connection	Screw-type terminals		
DC supply	<ul style="list-style-type: none"> • Internal • External <ul style="list-style-type: none"> – only required if a bus device is switched off or fails but communication with it is to be maintained – supply via separate mains supply – +24 V DC ± 10%, max. 100 mA per module 		
Insulation voltage to reference earth/PE	50 V AC		
Ambient temperature	Operation: 0 ... +55°C Transport: -25 ... +70°C Storage: -25 ... +60°C		
Climatic conditions	Class 3K3 to EN 50178 (without condensation, average relative humidity 85%)		



PROFIBUS

PROFIBUS	Order ref.	EMF2133IB
-----------------	-------------------	------------------

The communication module enables the inverter to support the PROFIBUS-DP profile.

- Two LEDs are located on the communication module to indicate the communication status.
- A configuration diskette for PROFIBUS-DP containing the description file for the devices (EDS file) is included in the scope of supply.
- The address can be adjusted via the DIP switch.
- Can be switched to the functionality of the 2131IB predecessor communication module via a DIP switch.

General data and application conditions

Communication medium	RS485
Communication profile	PROFIBUS-DP (DIN 19245 Part 1 and Part 3)
Selectable drive profile	<ul style="list-style-type: none"> • DRIVECOM profile "Drive technology 20" • PROFIDRIVE • Lenze device control
Baud rate [kBit/s]	9.6...12000 (automatic detection)
PROFIBUS-DP device	Slave
Network topology	Without repeater: line With repeaters: line or tree
Process data words (PCD) (16 bits)	1...12 words (2133IB with 8200 vector: max. 3 words; only with Servo PLC/Drive PLC: max. 12 words)
DP user data length	Parameter channel (4 words) + process data words
Max. number of devices	Standard: 32 (= 1 bus segment) including host system With repeaters: 128 including host system and repeaters
Max. cable length per bus segment	1200 m (depending on baud rate and cable type used)
Electrical connection	Screw-type terminal and SUB-D socket (9-pin)
DC supply	<ul style="list-style-type: none"> • Internal • External <ul style="list-style-type: none"> - only required for bus devices which are to be disconnected from the mains, but communication with the master is to be maintained - supply via separate mains supply - +24 V DC \pm 10%, max. 120 mA per module
Insulation voltage to reference earth/PE	50 V AC
Ambient temperature	Operation: 0 ... +55°C Transport: -25 ... +70°C Storage: -25 ... +60°C
Climatic conditions	Class 3K3 to EN 50178 (without condensation, average relative humidity 85%)



INTERBUS

INTERBUS	Order ref.	EMF2111IB
INTERBUS	Order ref.	EMF2113IB

The communication module enables the inverter to support the DRIVECOM drive profile “Drive technology 21” or Lenze device control (optional). INTERBUS interfacing takes place directly on the remote bus.

- Two LEDs are located on the communication module to indicate the communication status.
- EMF2113IB: The baud rate and process data words/parameter data words can be adjusted via the DIP switch.

Communication medium	RS485
Selectable drive profile	<ul style="list-style-type: none"> • Lenze device control • DRIVECOM profile “Drive technology 21”
Baud rate	500 kBit/s (2113IB: 500 kBit/s or 2 MBit/s)
INTERBUS device	Slave
Network topology	Ring (go and return lines in the same bus cable)
Process data words (PCD) (16 bits)	2... 3 words (2113IB with Drive PLC/Servo PLC: max. 10 words)
Parameter data words (PCP) (16 bits)	1 word (2113IB: max. 4 words)
INTERBUS code (ID code)	Decimal: 227; hex: E3
Max. PDU length	64 bytes
Supported PCP services	Initiate, Abort, Status, Identify, Get-OV-Long, Read, Write
Number of devices	Depends on the host system (I/O range), max. 63
Max. distance between 2 devices	400 m
Electrical connection	Screw-type terminal and SUB-D socket/connector (9-pin)
DC supply	<ul style="list-style-type: none"> • Internal • External <ul style="list-style-type: none"> – required if the communication ring must not be interrupted if a bus device is switched off or fails – supply via separate mains supply – +24 V DC ± 10%, max. 100 mA per module
Insulation voltage to reference earth/PE	50 V AC
Ambient temperature	Operation: 0 ... +55°C Transport: -25 ... +70°C Storage: -25 ... +60°C
Climatic conditions	Class 3K3 to EN 50178 (without condensation, average relative humidity 85%)



INTERBUS Loop

INTERBUS Loop	Order ref.	EMF2112IB
----------------------	-------------------	------------------

The communication module enables the inverter to support the DRIVECOM drive profile "Drive technology 20" or Lenze device control (optional). INTERBUS Loops can be integrated within the INTERBUS network.

Here, the DC supply to the communication modules is provided via the bus line of the INTERBUS Loop. Two LEDs are located on the communication module to indicate the communication status.

General data and application conditions

Selectable drive profile	<ul style="list-style-type: none"> • Lenze device control • DRIVECOM profile "Drive technology 20"
Baud rate [kBit/s]	500
INTERBUS device	Slave
Network topology	Ring
Process data words (PCD) (16 bits)	2 words
Parameter data words (PCP) (16 bits)	Not supported
INTERBUS code (ID code)	Decimal: 179; hex: B3
Max. PDU length	4 bytes
Supported PCP services	None
Max. number of devices	36 Lenze inverters
Max. loop length	200 m
Max. distance between 2 devices	20 m
Electrical connection	Screw-type terminals
DC supply	Via the bus
Insulation voltage to reference earth/PE	50 V AC
Ambient temperature	Operation: 0 ... +55°C Transport: -25 ... +70°C Storage: -25 ... +60°C
Climatic conditions	Class 3K3 to EN 50178 (without condensation, average relative humidity 85%)



LON

LON	Order ref.	EMF2141IB
------------	-------------------	------------------

The communication module enables the inverter to support the LONMARK "Variable Speed Motor Drive" functional (communication) profile.

- Two LEDs are located on the communication module to indicate the communication status.

- A configuration diskette for CANopen containing the description file for the devices and the plug-in for the LonMaker software is included in the scope of supply.

General data and application conditions

Communication medium	FTT - 10 A (Free Topology Transceiver)
Communication profile	LONMARK® Functional profile "Variable Speed Motor Drive"
Network topology	Free topology (line, tree/line, star, ring)
Possible number of nodes	64
Max. cable length	2700 m with bus topology (line) 500 m with mixed topology
Baud rate [kBit/s]	78
Electrical connection	Screw-type terminals
DC supply	<ul style="list-style-type: none"> • Internal • External <ul style="list-style-type: none"> - required if a bus device is switched off or fails but communication with it is to be maintained - supply via separate mains supply - +24 V DC ± 10%, max. 120 mA per module
Insulation voltage to reference earth/PE	50 V AC
Ambient temperature	Operation: 0 ... +55°C Transport: -25 ... +70°C Storage: -25 ... +60°C
Climatic conditions	Class 3K3 to EN 50178 (without condensation, average relative humidity 85%)



LECOM-AB (RS232/485)

LECOM-AB (RS232/485)	Order ref.	EMF2102IB-V001 ¹⁾
LECOM-B (RS485)	Order ref.	EMF2102IB-V002 ¹⁾

The communication modules enable the inverter to support the LECOM-AB V2.0 communication profile. The Lenze LECOM profile is completely open. Components which support this protocol are available for various systems (e.g. Simatic S5) in order to facilitate integration into a control system.

The LECOM-B communication module has an RS485 interface. In addition to the RS485 interface (see LECOM-B for data and operating conditions), the LECOM-AB communication module has an RS232 interface with a 9-pin SUB-D socket. Three LEDs are located on the communication modules to indicate the communication status.

General data and application conditions

Communication medium	RS485 (LECOM-B)	RS232 (LECOM-A)
Communication protocol	LECOM A/B V2.0	
Transfer character format	7E1: 7-bit ASCII, 1 stop bit, 1 start bit, 1 parity bit (even)	
Baud rate [Bit/s]	1200, 2400, 4800, 9600, 19200	
LECOM-B device	Slave	-
Network topology	Without repeater: line With repeaters: line or tree	Point-topoint
Max. number of devices	32 (= 1 bus segment) including host system With repeaters: 90 slaves	1
Max. cable length	1000 m per bus segment (depending on baud rate and cable type used)	15 m
Electrical connection	Screw-type terminals	SUB-D socket (9-pin)
DC supply	<ul style="list-style-type: none"> • Internal • External - required if bus devices are to be disconnected from the mains but communication with the master must be maintained - supply via separate mains supply - +24 V DC \pm 10%, max. 60 mA per module (LECOM-AB: max. 80 mA) 	
Insulation voltage to reference earth/PE	50 V AC	
Ambient temperature	Operation: 0 ... +55°C Transport: -25 ... +70°C Storage: -25 ... +60°C	
Climatic conditions	Class 3K3 to EN 50178 (without condensation, average relative humidity 85%)	

¹⁾ Descendant product EMF2102IBCV001, EMF2102IBCV002 currently being developed



LECOM-LI (optical fibres)

LECOM-LI	Order ref.	EMF2102IB-V003 ¹⁾
RS232/optical fibre converter Normal output power (0...40 m)	Order ref.	EMF2125IB
RS232/optical fibre converter High output power (10...66 m)	Order ref.	EMF2126IB

The communication module enables the inverter to support the LECOM-AB V2.0 communication module and interfaces the inverter with the host computer via an optical fibre converter.

Three LEDs are located on the communication module to indicate the communication status.

General data and application conditions

Communication medium	Optical fibres
Communication protocol	LECOM A/B V2.0
Transfer character format	7E1: 7-bit ASCII, 1 stop bit, 1 start bit, 1 parity bit (even)
Baud rate [Bit/s]	1200, 2400, 4800, 9600, 19200
LECOM-LI device	Slave
Network topology	Ring
Max. number of devices	52
Max. cable length per bus segment	0...40 m (normal output power)/10...66 m (high output power)
Electrical connection	Screw-type terminal and screw-type crimp connections
DC supply	<ul style="list-style-type: none"> • Internal • External <ul style="list-style-type: none"> – required if bus devices are to be disconnected from the mains, but communication with the master must be maintained – supply via separate mains supply – +24 V DC ± 10%, max. 70 mA per module
Insulation voltage to reference earth/PE	50 V AC
Ambient temperature	Operation: 0 ... +55°C Transport: -25 ... +70°C Storage: -25 ... +60°C
Climatic conditions	Class 3K3 to EN 50178 (without condensation, average relative humidity 85%)

¹⁾ Descendant product EMF2102IBC003 currently being developed



Drive PLC – Description

The Drive PLC adds a freely programmable drive PLC to the 8200 vector frequency inverter. This combination will not only control movement in your machine, but can also manage the distributed control functions. The system is programmed using the PLC languages of the international standard IEC 61131-3.

Lenze can offer a full automation system for your application, ranging from the operating and display units (keypads) to the geared motors. As an additional bonus, Lenze can now save you time by providing the software that brings your machines to life from the basic configurations and technology functions, using the IEC 61131-3 languages you are already familiar with.

Why do you need a Drive PLC?

What benefits does the Drive PLC offer over a standard PLC?

- Reduction of parallel wiring and unnecessary terminals through an integrated system bus interface (CAN) to the 8200 vector frequency inverter
- Straightforward engineering through a special software library for simple integration of the 8200 vector into the PLC program
- Straightforward integration of most fieldbuses through plug-on modules
- A cost-effective system with extensive basic functions
- No additional costs for gateway functions to higher-level bus systems such as INTERBUS or PROFIBUS.
The gateway function is automatically implemented in the system bus (CAN) by the operating system of the Drive PLC.

Drive PLC – Description

Would you like to . . .

- Rationalise the electrical part of your machine?
- Have more transparent PLC programs?
- Take the load off your bus system?
- Not have to keep learning new programming languages?
- Be able to implement drive-orientated control functions in the drive?
- Be able to use tried and tested systems for more complex drive solutions?

. . . then you should take a closer look at the Drive PLC.

This is because the Drive PLC can offer:

- Programming in the five IEC 61131-3 programming languages as well as high-performance CFC editor for simple graphic programming
- Continued complex drive technology solutions implemented via pre-configured technology functions
- The option of integrating the technology functions into the PLC program

. . . and this is what you get:

- Distributed control of your machine
- The electrical part of the machine becomes more cost-effective whilst maintaining the same level of performance
- Faster set-up times through the high-performance “Drive PLC Developer Studio” software development environment
- Increased availability due to the reduction in number of individual control components
- Less requirement for programming training: IEC 61131-3 is the international standard

Lenze will provide you with a freely programmable Drive PLC for the 8200 vector frequency inverter:

- Drive PLC as an expansion of the 8200 vector

The Drive PLC is programmed using a PC and the user-friendly Drive PLC Developer Studio software development environment. Please refer to the Lenze “Automation” catalog for further details.

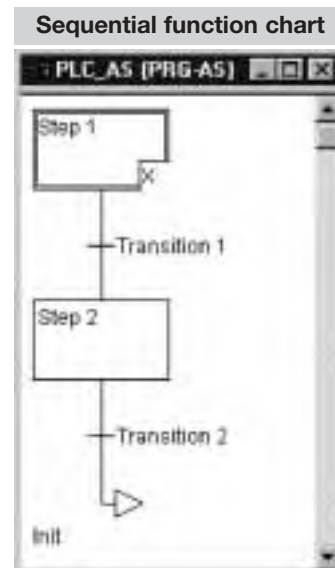
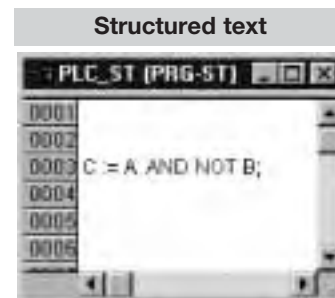
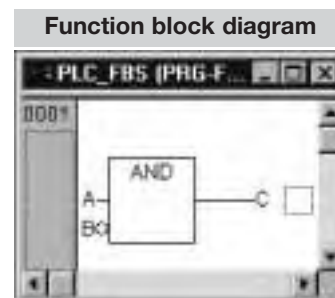
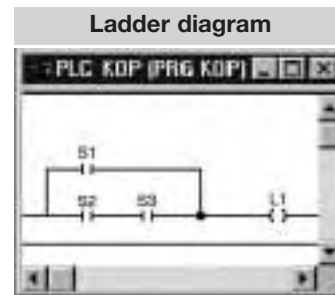
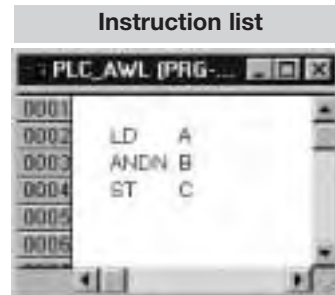

Drive PLC – Technical data

Program memory	191 kB
Data memory	9.5 kB (1.3 kB marker +8.2 kB variables)
EEProm buffered memory	800 bytes
Residual memory	200 bytes
Task types	1 cyclical task 8 tasks (time or event-controlled)
Processing time for a bit operation	1.0 µs
Number of counters/timers	Freely selectable in accordance with IEC 1131
Digital inputs	8 (3 of which have interrupt capability)
Expandable	Via extension board and distributed terminals
Digital outputs	4 (1 A each)
Extendable	Via extension board and distributed terminals
Analog inputs	3 (± 10 V, 11-bit)
Analog outputs	1 (± 10 V or ± 20 mA, 11-bit)
Communication interfaces	Integrated system bus (similar to CANopen) Plug-on communications modules (e.g. INTERBUS, PROFIBUS-DP)
Dimensions (H x W x D) / [mm]	120 x 60 x 140
Operational reserve	In accordance with IEC 1131
Programming software	Drive PLC Developer Studio with IL, LD, SFC, ST programming languages, ST, IL, CFC, debugging and monitoring, visualisation
Voltage supply	+18...30 V DC
Current (at 24 V DC)	200 mA (without output loads)

Name	Order ref.
Drive PLC	EPL-10200

Required components for programming:

Name	Order ref.
Drive PLC Developer Studio BASIC	ESP-DDS1-B
Drive PLC Developer Studio PROFESSIONAL	ESP-DDS1-P
PC system bus converter (voltage supply via keyboard with DIN connection)	EMF2173IB
PC system bus converter (voltage supply via keyboard with PS2 connection)	EMF2173IB-V002
System cable R232 (0.5 m)	EWL0048
System cable R232 (5.0 m)	EWL0020
System cable R232 (10 m)	EWL0021

Note:

The Drive PLC is programmed on the PC via the system bus.

Drive PLC – Mechanical installation

- Designed to be installed in a cabinet.
- If the exhaust air contains pollutants (dust, lint, grease, aggressive gases) then appropriate counter-measures must be in place (e.g. installation of filters, regular cleaning etc.).
- Ensure there is enough mounting space.
 - Several units can be mounted directly adjacent to one another without clearance.
 - Make sure that there is free access for cooling air and that the outlet for used air is not blocked.
 - Ensure a clearance of 100 mm above and below.
- In the event of continuous oscillations or vibrations, check the use of vibration dampers.

The Drive PLC can be fitted as follows into a control cabinet:

- With the enclosed **standard fixtures** (included in the scope of supply)
- With a **swivel bracket** (accessories)
- With **DIN rail fixtures** (accessories)

Tip:
E82ZWEK (with bracket) or E82ZWES (with clamp) fixings can be used (accessories) for quick and easy installation.

Standard fixtures

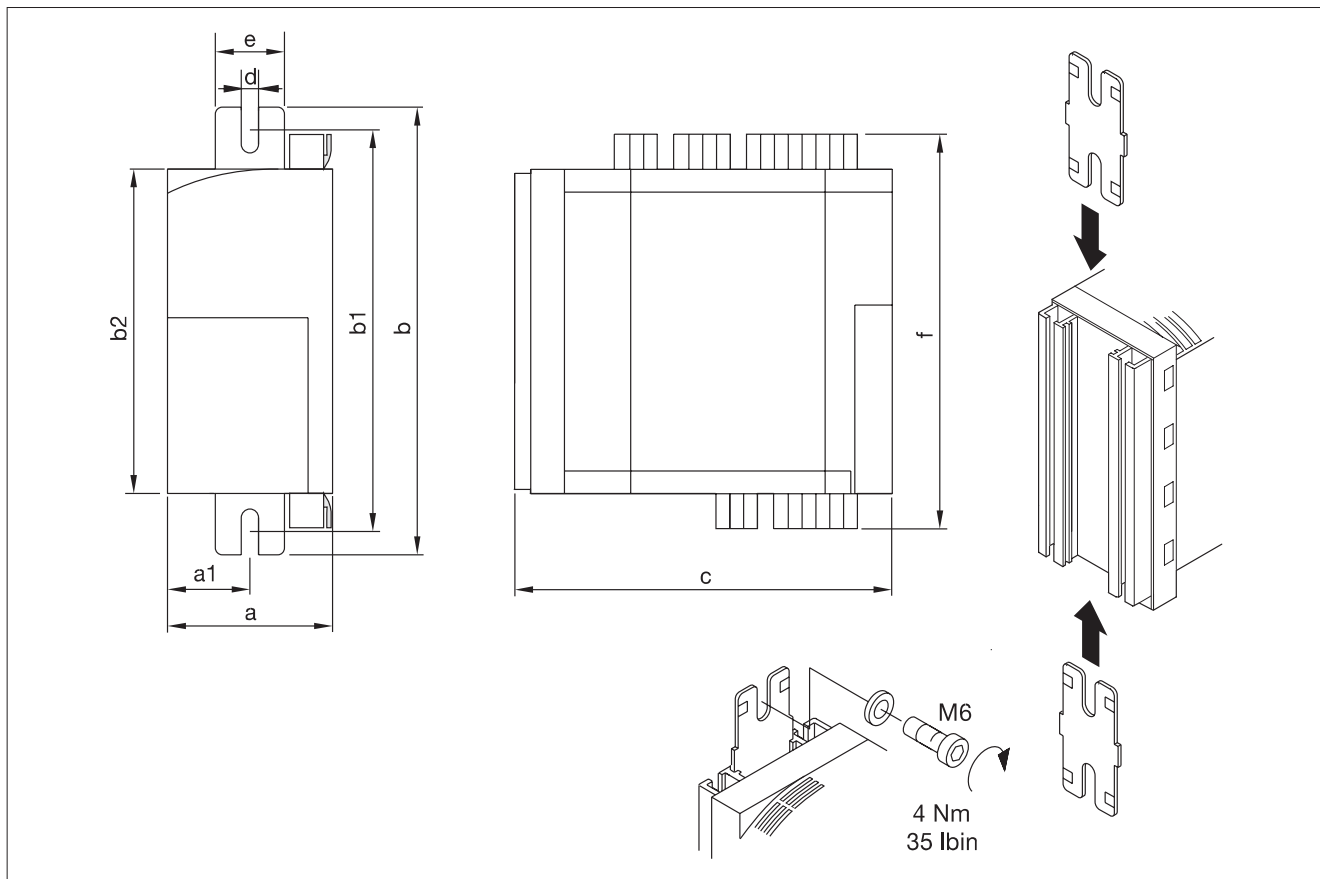

Dimensions [mm]								
a	a1	b	b1	b2	c	d	e	f
60	30	167	147...157	120	140	6,5	27.5	148

Drive PLC – Mechanical Installation

Mounting with a swivel bracket/side mounting

On housings with a shallow installation depth the Drive PLC can be mounted with a swivel bracket. The Drive PLC can be swivelled out sideways, e.g. through 90°, for

installation, adjustment and diagnostic purposes (locking mechanisms at 45°, 90°, 135°, 180°). The swivel bracket can also be used for fixed sideways mounting.

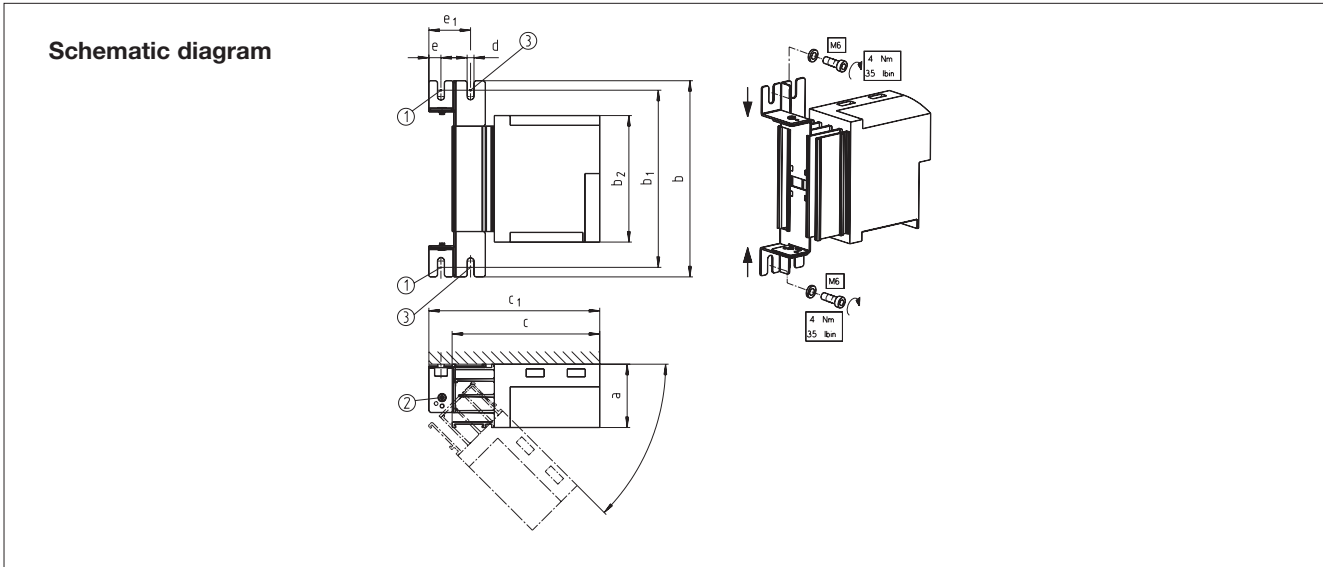

① Bolt here ② Pivot point ③ Bolt here to keep the Drive PLC fixed in the 0° position

Order ref.	a [mm]	b [mm]	b ₁ [mm]	b ₂ [mm]	c [mm]	c ₁ [mm]	d [mm]	e [mm]	e ₁ [mm]
E82ZJ001	60	203	177...192	120	140	162	6.5	11.5	39

DIN rail mounting

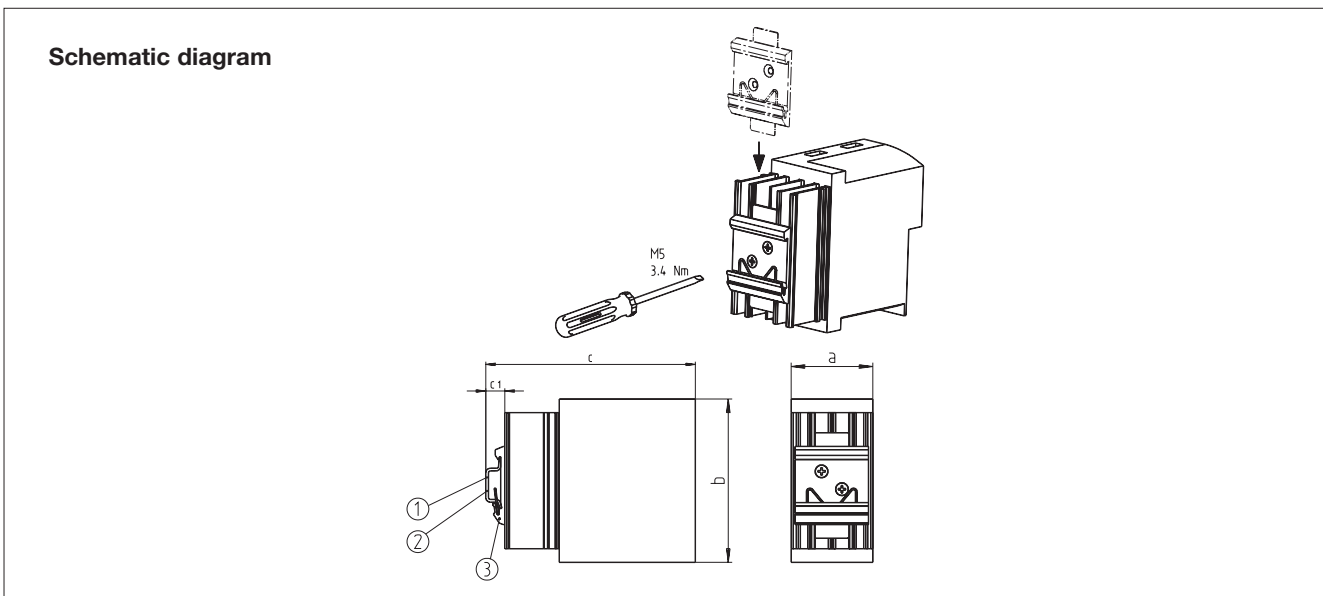

	a [mm]	b [mm]	c [mm]		c ₁ [mm]	
Order ref.			①	②	①	②
E82ZJ002	60	120	158	151	18	11

① DIN rail 35 x 15 or ② DIN rail 35 x 7.5 ③ DIN rail mounting

Tip: The DIN rail fixture can be positioned freely on the rear panel of the Drive PLC.

Drive PLC – Electrical installation

Terminals on the upper side of the device

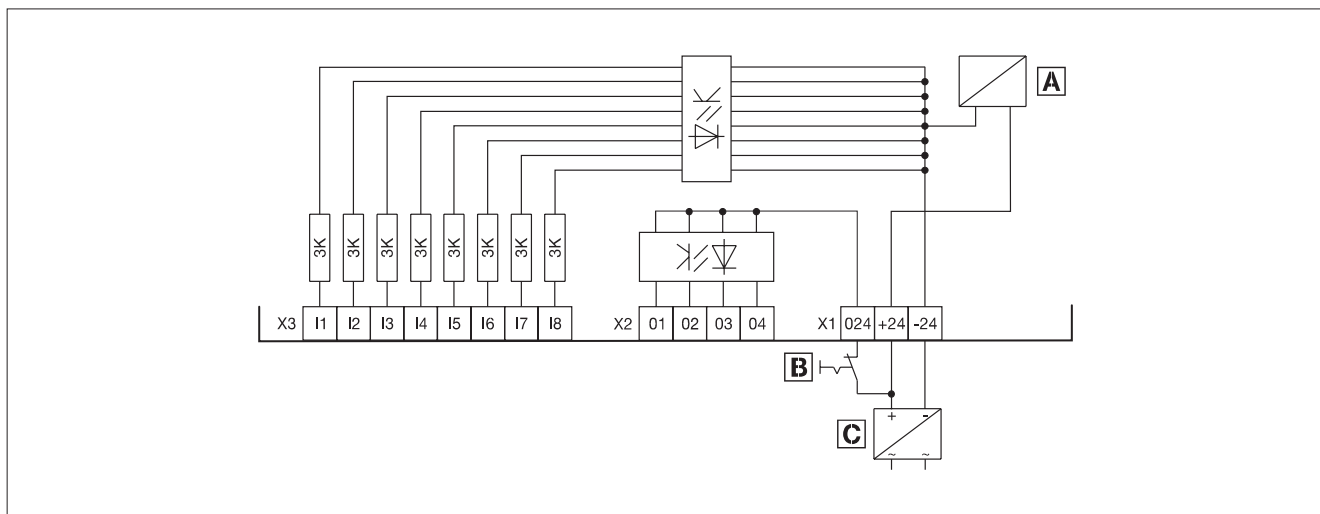

A Control electronics supply

B Emergency stop

C External DC supply

X1	Voltage supply	Level
κ 24	GND voltage supply	Reference potential
+24	Supply voltage	+18 ... +30 V DC
+024	Supply voltage for digital outputs	+18 ... +30 V DC

X2	Digital outputs	Level
01	Output 1	+18 ... +30 V DC
:	:	
04	Output 4	

X3	Digital inputs	Level
I1	Input 1	LOW level 0 ... +4 V DC
:	:	HIGH level +13 ... +30 V DC
I8	Input 8	Input current 8 mA at 24 V DC

Drive PLC - Electrical installation

Terminals on the underside of the device

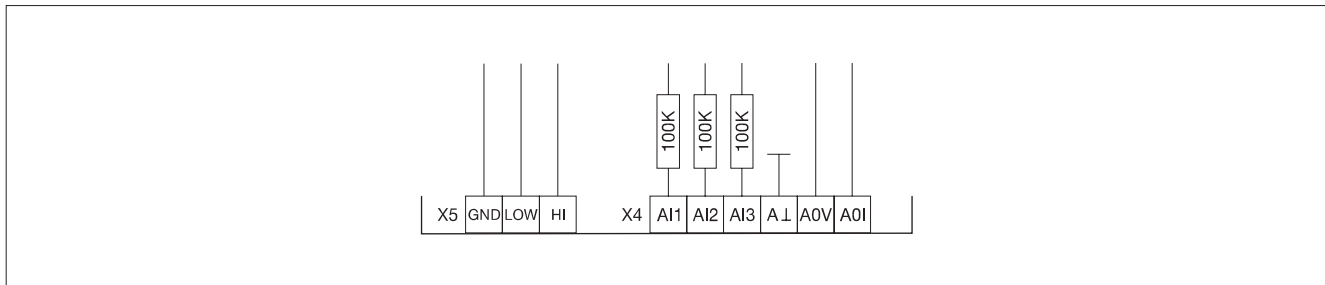

X4	Analog I/O	Level
AI1	Analog input 1	± 10 V (10-bit + sign)
AI2	Analog input 2	
AI3	Analog input 3	
A _k	Analog GND	Reference potential
A0V	Analog output voltage	± 10 V (10-bit + sign)
A0i	Analog output current	± 20 mA (10-bit + sign)

X5	System bus (CAN)	Level
GND		Reference potential
LOW	CAN-LOW	System bus LOW (data cable)
HI	CAN-HIGH	System bus HIGH (data cable)

Extension board

The extension board can be fitted sideways into the Drive PLC. This simple solution allows the type and number of input/output terminals to be expanded quickly and easily.



Extension Board 1	Connections
for the connection of three-wire sensors and outputs for 24 V brake actuation	6 digital inputs, 24 V DC, potential-free Low level: 0...+4 V DC High level: +13...+30 V DC
	4 digital outputs, +18...+30 V DC ¹⁾ potential-free, max. 1A
	2 digital outputs, +18...30 V DC ¹⁾ potential-free, max. 2A 5 terminals each for +24 V DC and GND (for three-wire sensors)
Extension Board 2	Connections
for the most cost-effective connection of digital sensors and actuators	14 digital inputs, 24 V DC, potential-free Low level: 0...+4 V DC High level: +13...+30 V DC
	8 digital outputs, +18...+30 V DC ¹⁾ potential-free, max. 1A
Extension Board 3	Connections
for rapid counting, length measurements and control technology applications	1 encoder input, TTL, HTL, 500 kHz, two-track with inverted signals and zero track
	8 digital inputs, 24 V potential-free Low level: 0...+4 V DC High level: +13...+30 V DC
	4 digital outputs, +18...30 V DC ¹⁾ potential-free max. 1A
	2 analog inputs \pm 10V (10-bit + sign)

¹⁾ = depending on the supply voltage (18...30 V DC)

Name	Order ref.
Extension Board 1	EPZ-10201
Extension Board 2	EPZ-10202
Extension Board 3	EPZ-10203

Terminal extension for system bus (CAN)

Order reference:	EMZ9374IB
-------------------------	------------------

The terminal extension serves to add extra digital input and output terminals to the system bus network. All 8 terminals are freely programmable as inputs or outputs. The reaction time of the terminals is 1-2 ms.

Overview

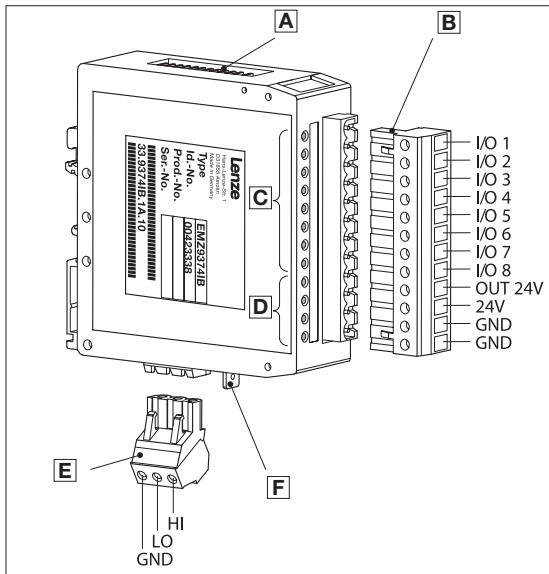

The diagram shows the EMZ9374IB terminal extension module with the following components labeled:

- A**: DIP switch for configuring the terminal extension
- B**: 12-pin terminal strip for connecting inputs/outputs and the supply voltage. Connections include IO 1 through IO 8, OUT 24V, 24V, GND, and 24V GND.
- C**: Yellow status LED for inputs/outputs I/O1...I/O8. LED ON indicates input/output is set; LED OFF indicates it is not set.
- D**: Diagnostic LED
- E**: 3-pin terminal strip for connecting the system bus (CAN). Connections include HI (System bus HIGH), LO (System bus LOW), and GND (Reference potential).
- F**: PE connector for the PE connection

Technical data

Electrical connection	Supply voltage	+18...+30 V DC				
	Current requirement	80 mA at +24 V DC				
Digital outputs	Features	<ul style="list-style-type: none"> No electrical isolation Short-circuit-proof 				
	Current per output	max. 1 A				
	Total current of all outputs	max. 4 A				
	HIGH level	+13...+30 V DC				
	LOW level	0...+5 V DC				
Digital inputs	Features	No electrical isolation				
	Input resistance	3 kΩ...4 kΩ				
	HIGH level	+13...+30 V DC				
	LOW level	0...+5 V DC				
System bus (CAN)	Communication profile	Similar to CANopen (CIA DS301) (compatible with Lenze automation components)				
	Communication medium	DIN ISO 11898				
	Network topology	Line (terminated at both ends with 120 Ω)				
	System bus device	Slave				
	Max. number of devices	63				
	Baud rate [kBit/s]	50	125	250	500	1000
	Max. bus length [m]	1000	500	250	80	25
Mounting	on DIN rail					
Dimensions	H x B x D [mm] 101 x 25 x 98 (incl. terminal strip)					

Process visualisation

Lenze's graduated range of displays can provide you with high-quality powerful products suitable for universal use. They offer high levels of user-friendliness and functionality which is reflected in their design. They provide a variety of functions:

- Display of text, images, bar graphs, bitmap images and animated graphics¹⁾
- Recipe management¹⁾
- Saving of data with access protection with password allocation
- Display of system messages
- Display of alarm messages¹⁾
- Communication via system bus
- Transparent bilingual parameterisation software
- Mathematical functions¹⁾
- Automatic operations¹⁾
- Real-time clock
- Windows fonts

	Order ref.:
H310	EPM-H310
H315	EPM-H315
H410	EPM-H410
H510	EPM-H510
H520	EPM-H520

¹⁾ Not available for all types

Displays



H310



H315



H410

Touchscreens



H520

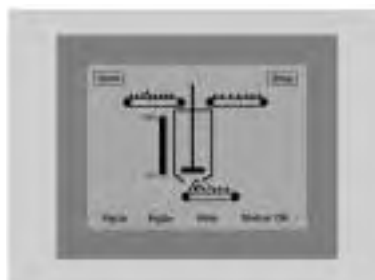

H510

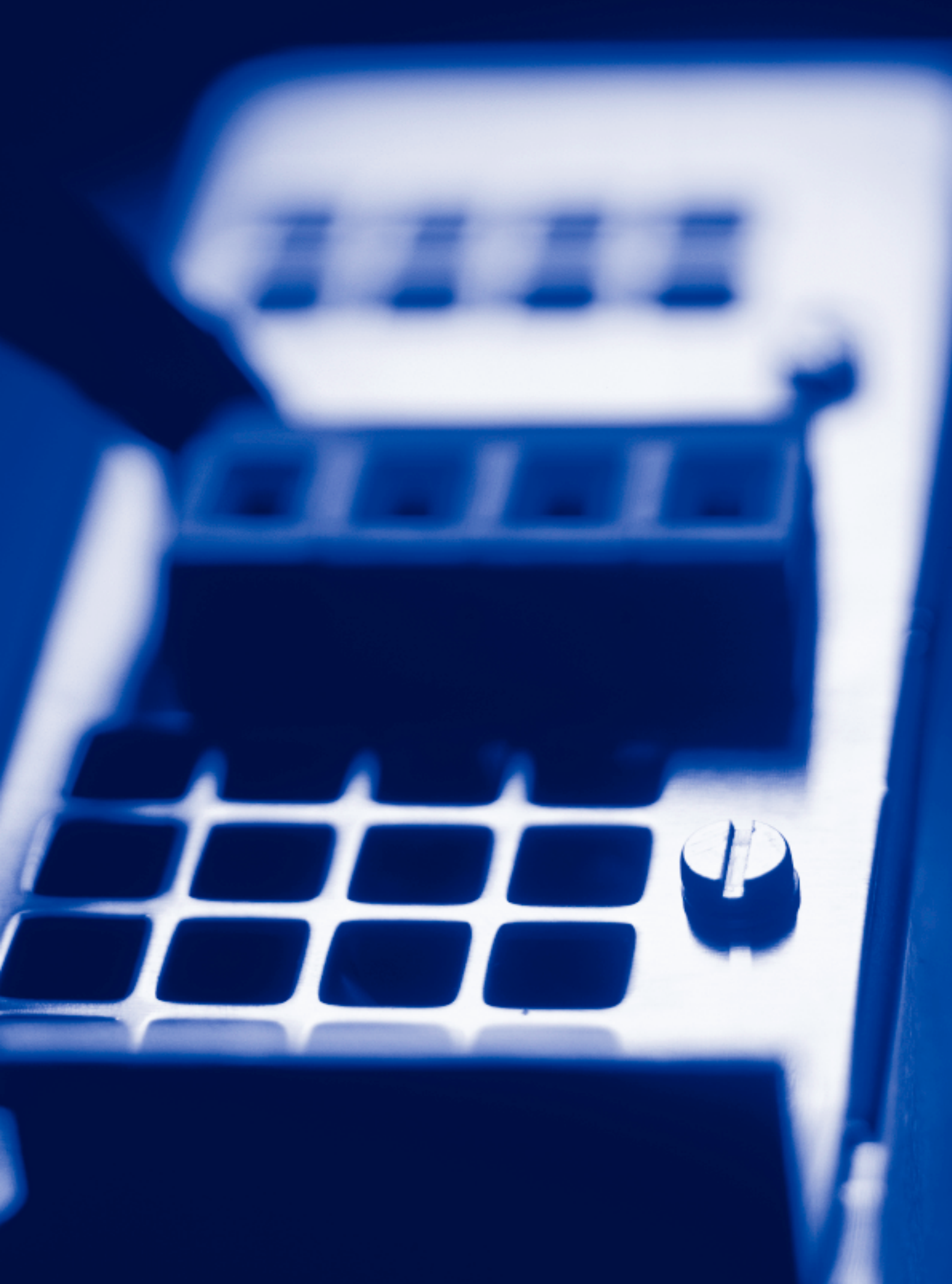

Accessories | 8200 vector

Overview _____	4-3	Braking _____	4-29
Cable protection _____	4-4	General _____	4-29
Fuses for operation with mains choke _____	4-4	Integrated brake transistors (0.25 kW...7.5 kW/230 V) _____	4-30
Fuse holders for operation with mains choke _____	4-5	Integrated brake transistors (0.55 kW...11 kW/400 V) _____	4-31
Circuit-breakers for operation with mains choke _____	4-6	Brake chopper and brake module (15.0 kW...90.0 kW/400 V) _____	4-32
Fuses for operation without mains choke _____	4-7	Brake resistors _____	4-36
Fuse holders for operation without mains choke _____	4-8	Brake rectifiers _____	4-38
Circuit-breakers for operation without mains choke _____	4-9	Group operation _____	4-42
Mains chokes _____	4-10	DC fuses _____	4-42
General _____	4-10	Miscellaneous _____	4-44
Mains chokes (0.25 kW...90 kW) _____	4-10	Setpoint potentiometer _____	4-44
Dimensions _____	4-11	Digital display _____	4-44
Radio interference suppression _____	4-14	EMC kit _____	4-45
General _____	4-14	PTC kit _____	4-45
Footprint RFI filters threshold class A and B (0.25 kW ... 2.2 kW) _____	4-15	Plug connector _____	4-45
Footprint RFI filters threshold class A and B (3 kW ... 11 kW) _____	4-16	“General accessories” overview tables _____	4-47
Footprint RFI filters threshold class A and B (15 kW ... 11 kW) _____	4-17	“Type-specific accessories” overview tables _____	4-49
Integrated RFI filters threshold class A (15 kW ... 90 kW) _____	4-18		
Integrated RFI filters threshold class B (15 kW ... 90 kW) _____	4-19		
Dimensions _____	4-20		
Motor filters _____	4-24		
General _____	4-24		
Motor filters (0.25 kW...2.2 kW/230 V) _____	4-25		
Motor filters (0.55 kW...2.2 kW/400 V) _____	4-26		
Motor filters (3.0 kW...11 kW/400 V) _____	4-27		
Motor filters (15.0 kW...90 kW/400 V) _____	4-28		

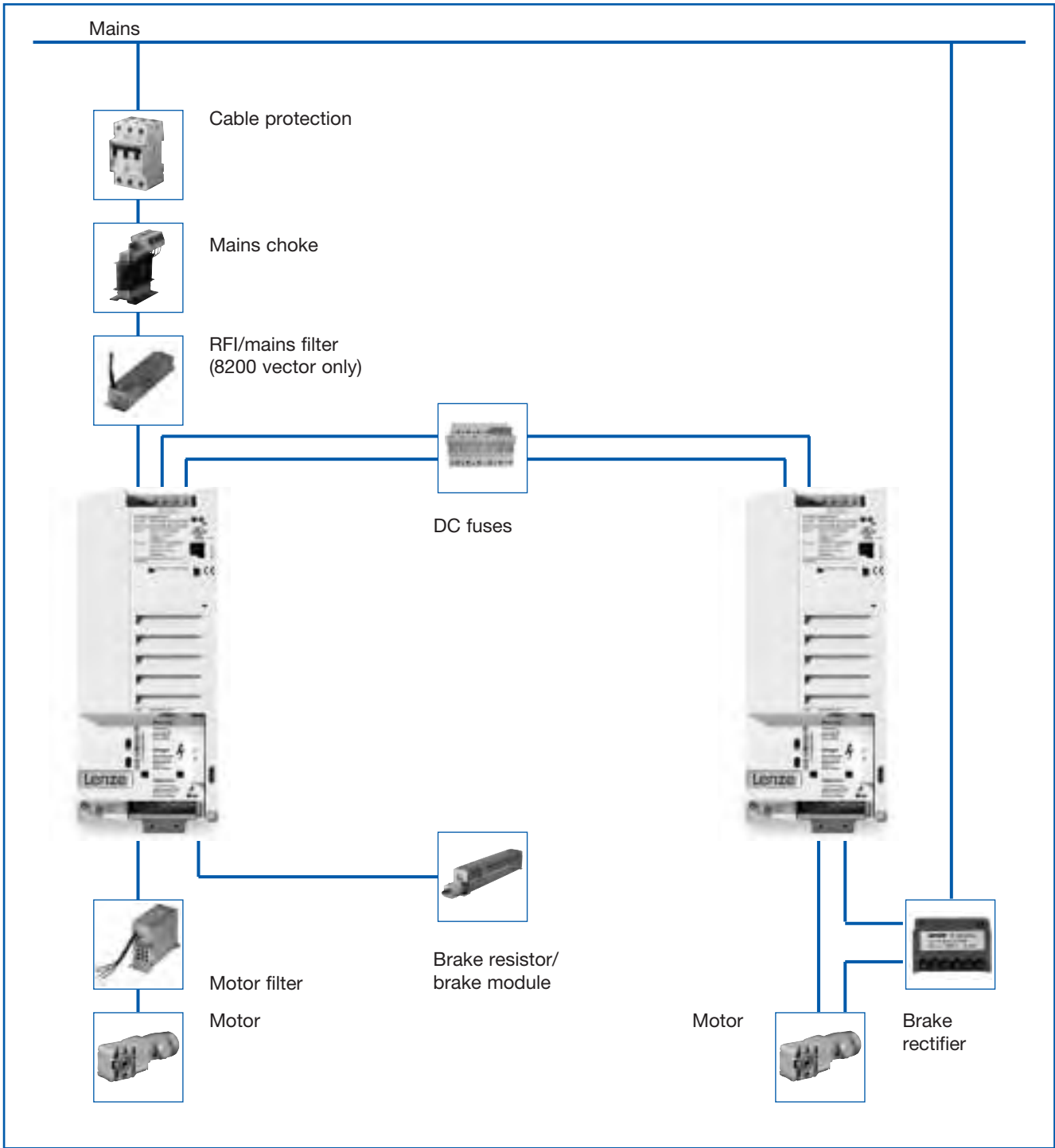

Select the accessories for your application on the following pages. The drive can be integrated into any type of application using the numerous accessories. RFI filters, mains chokes and mains filters are available to ensure adherence to EMC limiting values. Motor filters provide protection for motors whose isolation systems are not suitable for inverter operation. The combination of motor filters and RFI filters enables the inverters to be used in applications with long motor cables. Brake choppers, brake modules and brake resistors for converting braking energy into heat are available for braking large loads and

for dynamic applications. Lenze can provide a system of DC fuses and DC busbar systems to provide cable protection even in DC bus operation. The DC fuses have been designed for use with the 8200 vector.

Fuses for operation with mains choke

Fuses or circuit-breakers can be used to protect cables. Depending on the mains current supply of each frequency

inverter, the following current ratings are required for the protection devices:

8200 vector		Normal operation (150% overload)					Operation with increased power rating (120% overload)				
Type 1)	Voltage [V]	Fuse		Circuit-breaker VDE	Cable cross-section		Fuse		Circuit-breaker VDE	Cable cross-section	
		VDE	UL		mm ²	AWG	VDE	UL		mm ²	AWG
E82EV251K2C	1~ 230	M10 A	10 A	C10 A	1.5	16	M10 A	10 A	C10 A	1.5	16
E82EV371K2C		M10 A	10 A	C10 A	1.5	16	-	-	-	-	-
E82EV551K2C		M10 A	10 A	B10 A	1.5	16	M10 A	10 A	B10 A	1.5	16
E82EV751K2C		M10 A	10 A	B10 A	1.5	16	M16 A	15 A	B16 A	2.5	14
E82EV152K2C		M16 A	15 A	B16 A	2 x 1.5	2 x 16	M20 A	20 A	B20 A	2 x 1.5	2 x 16
E82EV222K2C		M20 A	20 A	B20 A	2 x 1.5	2 x 16	-	-	-	-	-
E82EV551K2C	3~ 230	M6 A	5 A	B6 A	1	18	M6 A	5 A	B6 A	1	18
E82EV751K2C		M6 A	5 A	B6 A	1	18	M10 A	10 A	B10 A	1.5	16
E82EV152K2C		M10 A	10 A	B10 A	1.5	16	M10 A	10 A	B10 A	1.5	16
E82EV222K2C		M10 A	10 A	B10 A	1.5	16	-	-	-	-	-
E82EV302K2C		M16 A	15 A	B16 A	2.5	14	M20 A	20 A	B20 A	4	12
E82EV402K2C		M20 A	20 A	B20 A	4	12	-	-	-	-	-
E82EV552K2C		M25 A	25 A	B25 A	4	10	M32 A	35 A	B32 A	6	8
E82EV752K2C		M35 A	35 A	-	6	8	-	-	-	-	-
E82EV551K4C	3~ 400	M6 A	5 A	B6 A	1	18	M6 A	5 A	B6 A	1	18
E82EV751K4C		M6 A	5 A	B6 A	1	18	M6 A	5 A	B6 A	1	18
E82EV152K4C		M10 A	10 A	B10 A	1.5	16	-	-	-	-	-
E82EV222K4C		M10 A	10 A	B10 A	1.5	16	M10 A	10 A	B10 A	1.5	16
E82EV302K4C		M10 A	10 A	B10 A	1.5	16	M10 A	10 A	B10 A	1.5	16
E82EV402K4C		M16 A	15 A	B16 A	2.5	14	M16 A	15 A	B16 A	2.5	14
E82EV552K4C		M20 A	20 A	B20 A	4	12	-	-	-	-	-
E82EV752K4C		M20 A	20 A	B20 A	4	12	-	-	-	-	-
E82EV113K4C		M32 A	25 A	B32 A	6	10	-	-	-	-	-
E82EV153K4C201	3~ 400	M35 A	35 A	-	10	8	M50 A	50 A	-	16	6
E82EV223K4C201		M50 A	50 A	-	16	6	M63 A	63 A	-	25	4
E82EV303K4C201		M80 A	80 A	-	25	3	M80 A	80 A	-	25	3
E82EV453K4C201		M100 A	100 A	-	50	1	M125 A	125 A	-	50	0
E82EV553K4C201		M125 A	125 A	-	50	0	M160 A	175 A	-	70	2/0
E82EV753K4C201		M160 A	175 A	-	70	2/0	M160 A	175 A	-	70	2/0
E82EV903K4C201		M200 A	200 A	-	95	3/0	M200 A	200 A	-	95	3/0

Please observe national and regional regulations

1) Also valid for E82CVxxxKx and E82DVxxxKx devices

For operation in UL approved installations, use only standard UL approved cables, fuses and fuse holders. UL fuse: Voltage 240 V or 500 V...600 V, tripping characteristic "H" or "K5".



Fuse holders for operation with mains choke

8200 vector		Fuse				Fuse holder	
Type ²⁾	Voltage [V]	Current rating	Size	Order ref.	Required number	Order ref.	Required number
E82EV251K2C	1~ 230	M10A	10 x 38	EFSM-0100AWE	1	EFH10001	1
E82EV371K2C		M10A	10 x 38	EFSM-0100AWE	1	EFH10001	1
E82EV551K2C		M10A	10 x 38	EFSM-0100AWE	1	EFH10001	1
E82EV751K2C		M10A M16A ¹⁾	10 x 38 10 x 38 ¹⁾	EFSM-0100AWE EFSM-0160AWE ¹⁾	1 1 ¹⁾	EFH10001 EFH10001 ¹⁾	1 1 ¹⁾
E82EV152K2C		M16A M20A ¹⁾	10 x 38 10 x 38 ¹⁾	EFSM-0160AWE EFSM-0200AWE ¹⁾	1 1 ¹⁾	EFH10001 EFH10001 ¹⁾	1 1 ¹⁾
E82EV222K2C		M20A	10 x 38	EFSM-0200AWE	1	EFH10001	1
E82EV551K2C	3~ 230	M6A	10 x 38	EFSM-0060AWE	3	EFH10001	3
E82EV751K2C		M6A M10A ¹⁾	10 x 38 10 x 38 ¹⁾	EFSM-0060AWE EFSM-0100AWE ¹⁾	3 3 ¹⁾	EFH10001 EFH10001 ¹⁾	3 3 ¹⁾
E82EV152K2C		M10A	10 x 38	EFSM-0100AWE	3	EFH10001	3
E82EV222K2C		M10A	10 x 38	EFSM-0100AWE	3	EFH10001	3
E82EV302K2C		M16A M20A ¹⁾	10 x 38 10 x 38 ¹⁾	EFSM-0160AWE EFSM-0200AWE ¹⁾	3 3 ¹⁾	EFH10001 EFH10001 ¹⁾	3 3 ¹⁾
E82EV402K2C		M20A	10 x 38	EFSM-0200AWE	3	EFH10001	3
E82EV552K2C		M25A M32A ¹⁾	14 x 51 14 x 51 ¹⁾	EFSM-0250AXH EFSM-0320AWH ¹⁾	3 3 ¹⁾	EFH10002 EFH10002 ¹⁾	3 3 ¹⁾
E82EV752K2C		M32A	14 x 51	EFSM-0320AWH	3	EFH10002	3
E82EV551K4C		3~ 400	M6A	10 x 38	EFSM-0060AWE	3	EFH10001
E82EV751K4C	M6A		10 x 38	EFSM-0060AWE	3	EFH10001	3
E82EV152K4C	M10A		10 x 38	EFSM-0100AWE	3	EFH10001	3
E82EV222K4C	M10A		10 x 38	EFSM-0100AWE	3	EFH10001	3
E82EV302K4C	M10A		10 x 38	EFSM-0100AWE	3	EFH10001	3
E82EV402K4C	M16A		10 x 38	EFSM-0160AWE	3	EFH10001	3
E82EV552K4C	M20A		10 x 38	EFSM-0200AWE	3	EFH10001	3
E82EV752K4C	M20A		10 x 38	EFSM-0200AWE	3	EFH10001	3
E82EV113K4C	M32A		14 x 51	EFSM-0320AWH	3	EFH10002	3

¹⁾ For operation with increased power rating (120% overload)

²⁾ Also valid for E82CVxxxKx and E82DVxxxKx devices

Note:

We recommend using standard fuses (not in the scope of supply) for types E82EV153K4C...E82EV903K4C.

Fuse holder dimensions

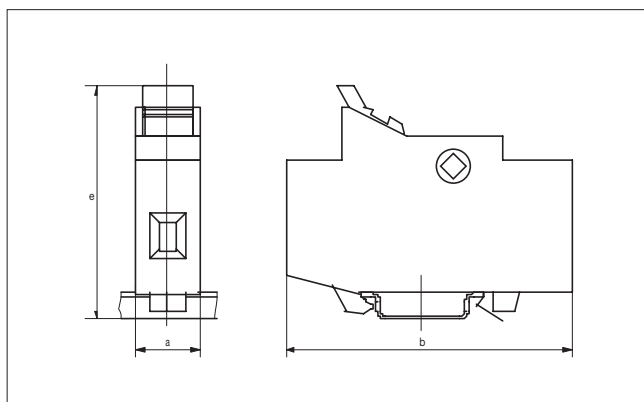

Type	a [mm]	b [mm]	e [mm]	Fuse dimensions
EFH10001	17.5	81	68	10 x 38
EFH10002	26	95	85	14 x 51

Circuit-breakers for operation with mains choke

8200 vector		Circuit-breakers			
Type ²⁾	Voltage [V]	Current rating	Order ref.	Required number	
E82EV251K2C	1~ 230	C10A	EFA1C10A	1	
E82EV371K2C		C10A	EFA1C10A	1	
E82EV551K2C		B10A	EFA1B10A	1	
E82EV751K2C		B10A B16A ¹⁾	EFA1B10A EFA1B16A ¹⁾	1 1 ¹⁾	
E82EV152K2C		B16A B20A ¹⁾	EFA1B16A EFA1B20A ¹⁾	1 1 ¹⁾	
E82EV222K2C		B20A	EFA1B20A	1	
E82EV551K2C	3~ 230	B6A	EFA3B06A	1	
E82EV751K2C		B6A B10A ¹⁾	EFA3B06A EFA3B10A ¹⁾	1 1 ¹⁾	
E82EV152K2C		B10A	EFA3B10A	1	
E82EV222K2C		B10A	EFA3B10A	1	
E82EV302K2C		B16A B20A ¹⁾	EFA3B16A EFA3B20A ¹⁾	1 1 ¹⁾	
E82EV402K2C		B20A	EFA3B20A	1	
E82EV552K2C		B25A B32A ¹⁾	EFA3B25A EFA3B32A ¹⁾	1 1 ¹⁾	
E82EV752K2C		-	-	-	-
E82EV551K4C		3~ 400	B6A	EFA3B06A	1
E82EV751K4C	B6A		EFA3B06A	1	
E82EV152K4C	B10A		EFA3B10A	1	
E82EV222K4C	B10A		EFA3B10A	1	
E82EV302K4C	B10A		EFA3B10A	1	
E82EV402K4C	B16A		EFA3B16A	1	
E82EV552K4C	B20A		EFA3B20A	1	
E82EV752K4C	B20A		EFA3B20A	1	
E82EV113K4C	B32A		EFA3B32A	1	

¹⁾ For operation with increased power rating (120% overload)

²⁾ Also valid for E82CVxxxKx and E82DVxxxKx devices

Miniature circuit-breaker dimensions

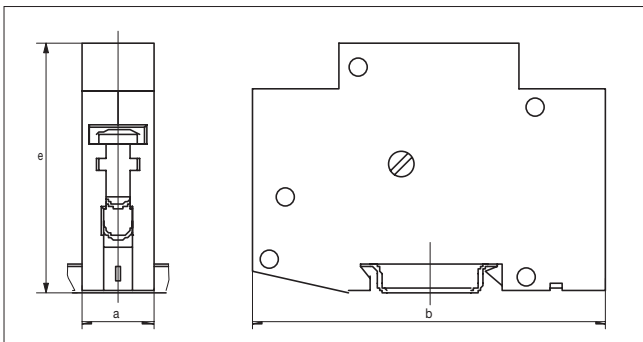

Type	a [mm]	b [mm]	e [mm]
EFA1xxxxA	17.5	90	63
EFA3BxxxA	53	90	63



EFA1xxxxA



EFA3BxxxA



Fuses for operation without mains choke

Fuses or circuit-breakers can be used to protect cables. Depending on the mains current supply of each frequency

inverter, the following current ratings are required for the protection devices:

8200 vector		Normal operation (150% overload)					Operation with increased power rating (120% overload)				
Type ¹⁾	Voltage [V]	Fuse		Circuit-breaker VDE	Cable cross-section		Fuse		Circuit-breaker VDE	Cable cross-section	
		VDE	UL		mm ²	AWG	VDE	UL		mm ²	AWG
E82EV251K2C	1~ 230	M10 A	10 A	C10 A	1.5	16	M10 A	10 A	C10 A	1.5	16
E82EV371K2C		M10 A	10 A	C10 A	1.5	16	-	-	-	-	-
E82EV551K2C		M10 A	10 A	B10 A	1.5	16	M10 A	10 A	B10 A	1.5	16
E82EV751K2C		M16 A	15 A	B16 A	2.5	14	Operation only with mains choke				
E82EV152K2C		M20 A	20 A	B20 A	2 x 1.5	2 x 16	M20 A	20 A	B20 A	2 x 1.5	2 x 16
E82EV222K2C		Operation only with mains choke					-	-	-	-	-
E82EV551K2C	3~ 230	M6 A	5 A	B6 A	1	18	M6 A	5 A	B6 A	1	18
E82EV751K2C		M10 A	10 A	B10 A	1.5	16	Operation only with mains choke				
E82EV152K2C		M16 A	15 A	B16 A	2.5	14	M16 A	15 A	B16 A	2.5	14
E82EV222K2C		M16 A	15 A	B16 A	2.5	14	-	-	-	-	-
E82EV302K2C		M20 A	20 A	B20 A	4	12	M25 A	25 A	B25 A	4	10
E82EV402K2C		M25 A	25 A	B25 A	4	10	-	-	-	-	-
E82EV552K2C		M35 A	35 A	-	6	8	Operation only with mains choke				
E82EV752K2C		Operation only with mains choke					-	-	-	-	-
E82EV551K4C	3~ 400	M6 A	5 A	B6 A	1	18	M6 A	5 A	B6 A	1	18
E82EV751K4C		M6 A	5 A	B6 A	1	18	Operation only with mains choke				
E82EV152K4C		M10 A	10 A	B10 A	1.5	16	-	-	-	-	-
E82EV222K4C		M10 A	10 A	B10 A	1.5	16	Operation only with mains choke				
E82EV302K4C		M16 A	15 A	B16 A	2.5	14	M16 A	B15 A	B 16	2.5	14
E82EV402K4C		M16 A	15 A	B16 A	2.5	14	Operation only with mains choke				
E82EV552K4C		M25 A	20 A	B25 A	4	12	-	-	-	-	-
E82EV752K4C		M32 A	25 A	B32 A	6	10	-	-	-	-	-
E82EV113K4C		Operation only with mains choke					-	-	-	-	-
E82EV153K4C201	3~ 400	M63A	63A	-	25	4	Operation only with a mains choke or mains filter				
E82EV223K4C201		Operation only with a mains choke or mains filter									
E82EV303K4C201		Operation only with a mains choke or mains filter									
E82EV453K4C201		Operation only with a mains choke or mains filter									
E82EV553K4C201		Operation only with a mains choke or mains filter									
E82EV753K4C201		Operation only with a mains choke or mains filter									

Please observe national and regional regulations

¹⁾ Also valid for E82CVxxxKx and E82DVxxxKx devices

For operation in UL approved installations, use only UL approved cables, fuses and fuse holders.
UL fuse: Voltage 240 V or 500 V...600 V, tripping characteristic "H" or "K5".

Fuse holders for operation without mains choke

8200 vector		Fuse				Fuse holder		
Type ²⁾	Voltage [V]	Current rating	Size	Order ref.	Required number	Order ref.	Required number	
E82EV251K2C	1~ 230	M10A	10 x 38	EFSM-0100AWE	1	EFH10001	1	
E82EV371K2C		M10A	10 x 38	EFSM-0100AWE	1	EFH10001	1	
E82EV551K2C		M10A	10 x 38	EFSM-0100AWE	1	EFH10001	1	
E82EV751K2C		M16A	10 x 38	EFSM-0160AWE	1	EFH10001	1	
E82EV152K2C		M20A	10 x 38	EFSM-0200AWE	1	EFH10001	1	
E82EV222K2C		Operation only with a mains choke						
E82EV551K2C	3~ 230	M6A	10 x 38	EFSM-0060AWE	3	EFH10001	3	
E82EV751K2C		M10A	10 x 38	EFSM-0100AWE	3	EFH10001	3	
E82EV152K2C		M16A	10 x 38	EFSM-0160AWE	3	EFH10001	3	
E82EV222K2C		M16A	10 x 38	EFSM-0160AWE	3	EFH10001	3	
E82EV302K2C		M20A M25A ¹⁾	10 x 38 14 x 51 ¹⁾	EFSM-0200AWE EFSM-0250AXH ¹⁾	3 3 ¹⁾	EFH10001 EFH10002 ¹⁾	3 3 ¹⁾	
E82EV402K2C		M25A	14 x 51	EFSM-0250AXH	3	EFH10002	3	
E82EV552K2C		M32A	14 x 51	EFSM-0320AWH	3	EFH10002	3	
E82EV752K2C		Operation only with a mains choke						
E82EV551K4C		3~ 400	M6A	10 x 38	EFSM-0060AWE	3	EFH10001	3
E82EV751K4C	M6A		10 x 38	EFSM-0060AWE	3	EFH10001	3	
E82EV152K4C	M10A		10 x 38	EFSM-0100AWE	3	EFH10001	3	
E82EV222K4C	M10A		10 x 38	EFSM-0100AWE	3	EFH10001	3	
E82EV302K4C	M16A		10 x 38	EFSM-0160AWE	3	EFH10001	3	
E82EV402K4C	M16A		10 x 38	EFSM-0160AWE	3	EFH10001	3	
E82EV552K4C	M25A		14 x 51	EFSM-0250AXH	3	EFH10002	3	
E82EV752K4C	M32A		14 x 51	EFSM-0320AWH	3	EFH10002	3	
E82EV113K4C	Operation only with a mains choke							

¹⁾ For operation with increased power rating (120% overload)

²⁾ Also valid for E82CVxxxKx and E82DVxxxKx devices

Note:

We recommend using standard fuses (not in the scope of supply) for types E82EV153K4C...E82EV903K4C.

Fuse holder dimensions

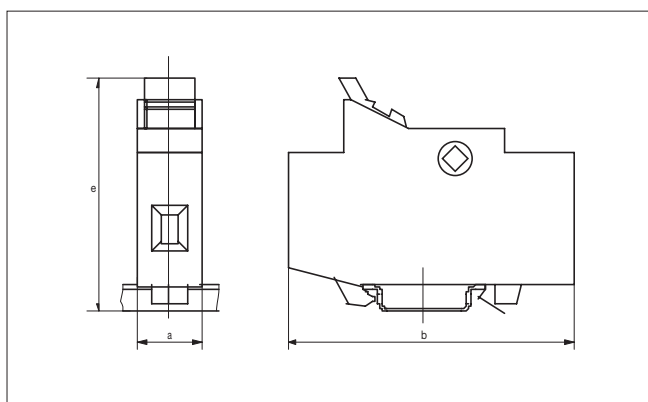

Type	a [mm]	b [mm]	e [mm]	Fuse dimensions
EFH10001	17.5	81	68	10 x 38
EFH10002	26	81	68	14 x 51



Circuit-breakers for operation without mains choke

8200 vector		Circuit-breakers		
Type 2)	Voltage [V]	Current rating	Order ref.	Required number
E82EV251K2C	1~ 230	C10A	EFA1C10A	1
E82EV371K2C		C10A	EFA1C10A	1
E82EV551K2C		B10A	EFA1B10A	1
E82EV751K2C		B16A	EFA1B16A	1
E82EV152K2C		B20A	EFA1B20A	1
E82EV222K2C		Operation only with mains choke		
E82EV551K2C	3~ 230	B6A	EFA3B06A	1
E82EV751K2C		B10A	EFA3B10A	1
E82EV152K2C		B16A	EFA3B16A	1
E82EV222K2C		B16A	EFA3B16A	1
E82EV302K2C		B20A B25A 1)	EFA3B20A EFA3B25A 1)	1 1 1)
E82EV402K2C		B25A	EFA3B25A	1
E82EV552K2C		-	-	-
E82EV752K2C		Operation only with mains choke		
E82EV551K4C	3~ 400	B6A	EFA3B06A	1
E82EV751K4C		B6A	EFA3B06A	1
E82EV152K4C		B10A	EFA3B10A	1
E82EV222K4C		B10A	EFA3B10A	1
E82EV302K4C		B16A	EFA3B16A	1
E82EV402K4C		B16A	EFA3B16A	1
E82EV552K4C		B25A	EFA3B25A	1
E82EV752K4C		B32A	EFA3B32A	1
E82EV113K4C		Operation only with mains choke		

1) For operation with increased power rating (120% overload)

2) Also valid for E82CVxxxKx and E82DVxxxKx devices

Miniature circuit-breaker dimensions

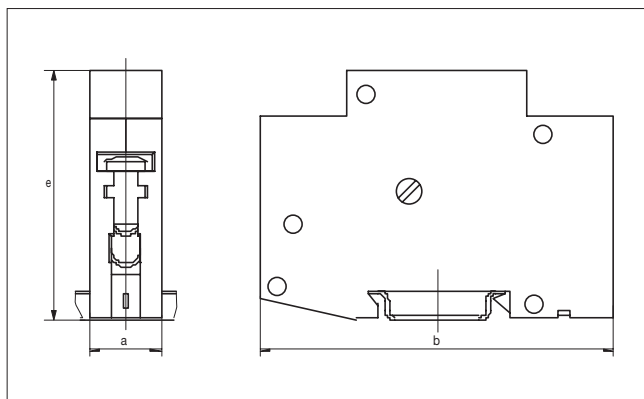

Type	a [mm]	b [mm]	e [mm]
EFA1xxxxA	17.5	80	63
EFA3BxxxA	53	90	63

Accessories

Mains chokes

General

A mains choke is an inductive resistor which can be connected between the mains supply and the frequency inverter.

Function:

- Less effects on the mains – the wave form of the mains supply is a closer approximation of a sine wave.
- Reduced mains current – reduction of the r.m.s. current (i.e. reduction of mains, cable and fuse load).
- Increased service life of the 8200 vector – The service life of electrolytic capacitors in the DC bus can be increased considerably by reducing the AC load.

Note:

- Mains chokes can be used without restrictions in conjunction with RFI filters and/or motor filters.
- A mains filter (combination of inductance and RFI filters in one housing) replaces the function of a mains choke (mains filters available for the 8200 vector, 15.0...90.0 KW).
Please note:
- Some 8200 vector frequency inverter models must always be equipped with a mains choke (see ¹⁾ and ²⁾ in the selection table)
- When using a mains choke, the maximum possible output voltage does not reach the value of the mains voltage – the typical mains voltage drop at the rated value is around 6%.

Mains chokes (0.25 kW...90 kW)

Type	8200 vector		Mains choke				
	Voltage [V]	Mains current [A] with mains choke for operation at		Order ref.	Inductance [mH]	I _r [A]	m [kg]
		150% overload ³⁾	120% overload ⁴⁾				
E82EV251K2C	1~ 230	3.0	3.5	ELN1-0900H005	9	5	2.3
E82EV371K2C		4.2	-				
E82EV551K2C		5.2	6.2	ELN1-0500H009	5	9	1
E82EV751K2C		7.5	9.0 ²⁾				
E82EV152K2C		12.5	15.0	ELN1-0250H018	2.5	18	2.3
E82EV222K2C		18.0 ¹⁾	-				
E82EV551K2C	3~ 230	2.7	3.3	E82ZL75132B	5.8	4.5	0.9
E82EV751K2C		3.6	4.4 ²⁾				
E82EV152K2C		6.3	7.6	E82ZL22232B	2.8	9.5	1.5
E82EV222K2C		9.0	-				
E82EV302K2C		12.0	14.4	ELN3-0120H017	1.2	17	3
E82EV402K2C		16.0	-				
E82EV552K2C	21.0	25.2 ²⁾	ELN3-0120H025 ELN3-0088H035 ⁴⁾	1.2 0.88	25 35	6 10	
E82EV752K2C	28.0 ¹⁾	-	ELN3-0088H035	0.88	35	10	
E82EV551K4C	3~ 400	2.0	2.1	EZN3A1500H003	15	3	1.1
E82EV751K4C		2.3	2.8 ²⁾				
E82EV152K4C		3.9	-	E82ZL22234B	6.8	6.1	2
E82EV222K4C		5.1	6.1 ²⁾				
E82EV302K4C		7.0	8.4	EZN3A0500H007 EZN3A0300H013 ⁴⁾	5 3	7 13	2.5 5.2
E82EV402K4C		8.8	10.6 ²⁾	EZN3A0300H013	3	13	5.2
E82EV552K4C		12.0	-				
E82EV752K4C		15.0	18.0 ²⁾	ELN3-0120H017 ELN3-0150H024 ⁴⁾	1.2 1.5	17 24	3 8.2
E82EV113K4C		21.0 ¹⁾	-	ELN3-0150H024	1.5	24	8.2
E82EV153K4C		29.0	39.0 ²⁾	ELN3-0088H035 ELN3-0075H045 ⁴⁾	0.88 0.75	35 45	10 10
E82EV223K4C		42.0 ¹⁾	50.0 ²⁾	ELN3-0075H045 ELN3-0055H055 ⁴⁾	0.75 0.55	45 55	10 19
E82EV303K4C		55.0 ¹⁾	60.0 ²⁾	ELN3-0055H055	0.55	55	19
E82EV453K4C		80.0 ¹⁾	97.0 ²⁾	ELN3-0038H085 ELN3-0027H105 ⁴⁾	0.38 0.27	85 105	19.5 20
E82EV553K4C		100.0 ¹⁾	119.0 ²⁾	ELN3-0027H105 ELN3-0020H130	0.27 0.27	105 130	20 20
E82EV753K4C		135.0 ¹⁾	144.0 ²⁾	ELN3-0022H130 ELN3-0017H170 ⁴⁾	0.22 0.17	130 170	20 32
E82EV903K4C		165.0 ¹⁾	185.0 ²⁾	ELN3-0017H170 ELN3-0014H200	0.17 0.14	170 200	32 32

¹⁾ Always use a mains choke

²⁾ Always use a mains choke when operating the system with increased power rating

³⁾ Standard operation (150% overload) with a mains rating of 230 V or 400 V

⁴⁾ Operation with increased power rating (120% overload)



Dimensions

Order ref.	Dimensions [mm]								
	a	b	c	d	e	f	k	m	n
ELN1-0900H005	66	67	50	53	80	62	80	4.8	9
ELN1-0500H009	66	67	50	53	80	62	80	4.8	9
ELN1-0250H018	97	-	84	61.3	98	-	90	5.8	9

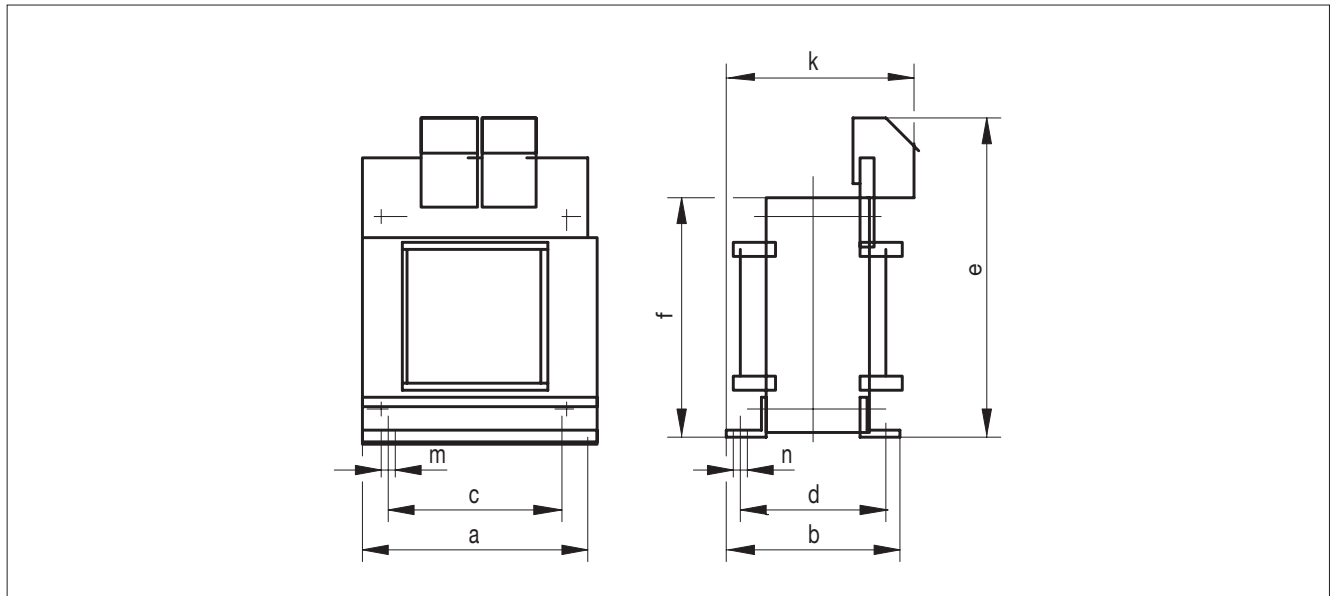

Dimensions

Order ref.	Dimensions [mm]								
	a	b	c	d	e	f	k	m	n
ELN3-0120H017	120	65	109	51	162	110	80	5	10
ELN3-0120H025	150	76	140	61	180	140	95	5	10
ELN3-0088H035	180	91	161	74	225	165	120	6.3	11
ELN3-0075H045	180	91	161	74	225	165	120	6.3	11
ELN3-0055H055	228	88	206	69	263	205	120	6.3	11
ELN3-0038H085	228	111	206	94	263	205	140	6.3	11
ELN3-0027H105	228	111	206	94	273	205	150	6.3	11
ELN3-0022H130	264	102	240	81	265	237	135	6.3	11
ELN3-0017H170	264	128	240	107	257	237	166	8.3	16
ELN3-0014H200	300	114	274	88	290	265	135	8.3	16

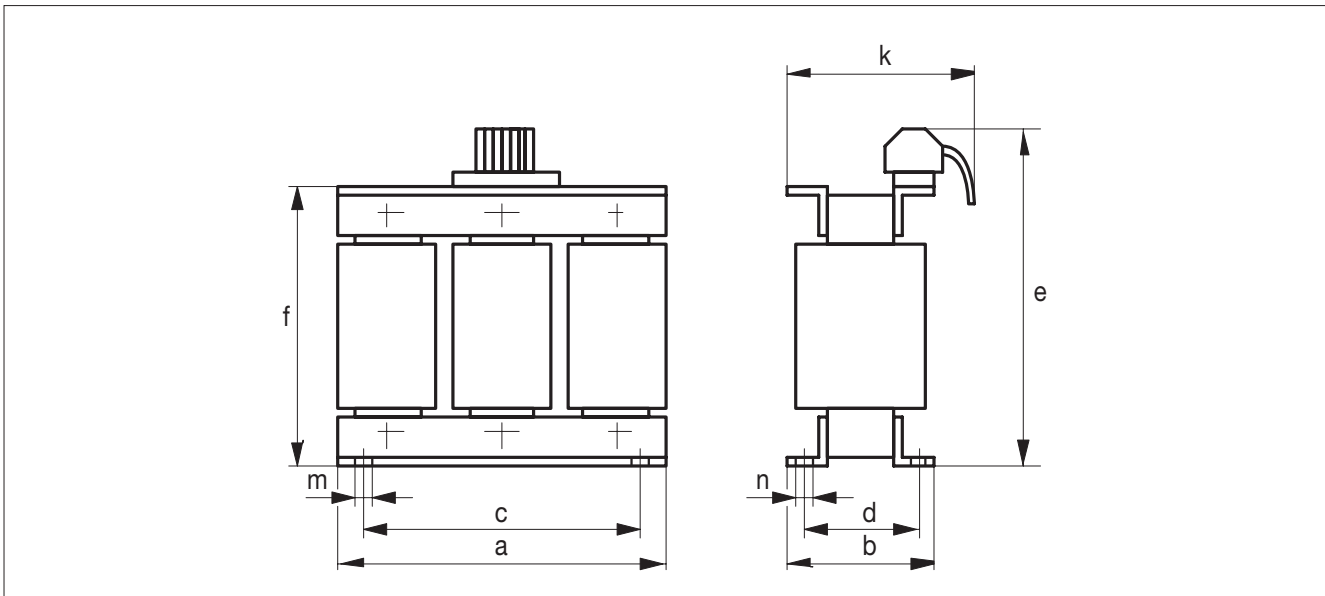

Terminal assignment

L1	L1.1	L2	L2.1	L3	L3.1





Dimensions

Order ref.	Dimensions [mm]								
	a	b	c	d	e	f	k	m	n
E82ZL75132B	95	49	56	36	113	-	-	4.8	9
E82ZL22232B	120	63	84	47	120	-	-	5.8	11
E82ZL22234B	120	61	84	45	126	-	70	5.8	11
EZN3A1500H003	95	48	56	35	115	-	82	5	9
EZN3A0500H007	119	63	90	49	138	-	95	5	9
EZN3A0300H013	150	81	113	64	162	-	106	6	11
ELN3-0150H024	180	86	136	67	192	-	120	7	12

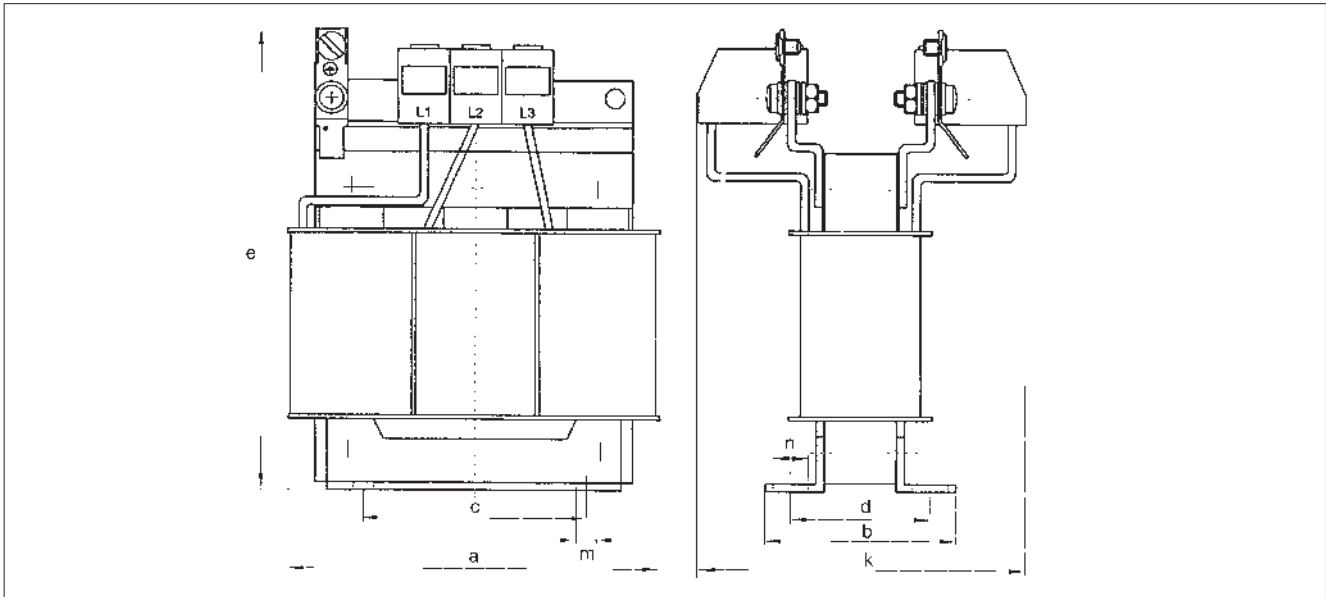

4

Terminal assignment

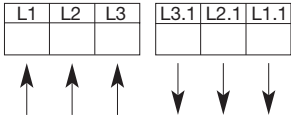

General

Every frequency inverter produces noise emission as a result of internal switching processes, which can impair the function of other equipment.

Limits for this type of interference are specified in European Standard EN 55011 depending on the operating location of the frequency inverter:

Threshold class A

Threshold class A is often required for industrial networks operating separately from mains supplies in domestic areas.

Threshold class B

If the frequency inverter is operated in a domestic environment, this may cause interference to other devices (e. g. radio and television sets). RFI filters in accordance with EN 55011, threshold B, often have to be used to counter this risk. Threshold class B is considerably more stringent than threshold class A. Threshold class B incorporates threshold class A.

Appropriate measures for reducing noise emission must be put in place to ensure that the device conforms to threshold class A or B. The selection of the frequency inverter and (if required) the corresponding filters always depends on the particular application, and is determined by various factors, including the operating frequency of the 8200 vector and the length of the motor cable or the protective circuit (e.g. residual current circuit-breaker).

Power	Type 8200 vector	Type of filter	Max. permissible motor cable length ¹⁾ for conformance with	
			Threshold class A	Threshold class B
0.25 ... 11.0 kW	E82EV251KxC to E82EV113KxC	integrated	20 m	1)
0.25 ... 0.75 kW	E82EV251K2C to E82EV751K2C	Footprint/built-on RFI filter LL ⁵⁾ (accessory)	5 m	
0.25 ... 11.0 kW	E82EV251KxC200 to E82EV113KxC200	Footprint/built-on RFI filter SD ³⁾ (accessory)	20 m	
		Footprint/built-on RFI filter LD (accessory)	50 m	
		Footprint/built-on RFI filter LD (accessory) + Motor filter ⁴⁾ (accessory)	200 m	100 m
15.0 ... 90.0 kW	E82EV153K4B3xx to E82EV903K4B3xx	Footprint/built-on mains filter ²⁾ (accessory)	50 m	10 m
	E82xV153K4B201 to E82xV553K4B201	Built-on mains filter ²⁾ (accessory)	25 m (mains filter A)	50 m (mains filter B)
	E82xV753K4B201 to E82EV903K4B201	Footprint/built-on mains filter ²⁾ (accessory)	25 m (mains filter A)	50 m (mains filter B)

¹⁾ Motor cable depends on the type of 8200 vector used and its operating frequency.

²⁾ Operation with increased rated power depends on the type of controller used

³⁾ SD (Short Distance) RFI filters are designed for operation at 30 mA RCCB (low leakage current) (guide value: Motor cable length = 10 m)

The residual current circuit-breaker may be triggered erroneously due to

- capacitive compensating currents in the cable shield during operation
- simultaneous switching on of several inverters on the network

⁴⁾ Please note the general data and application conditions of the motor filter (see page 4-24)

⁵⁾ For non-fixed systems: Discharge current < 3.5 mA



Footprint RFI filters threshold class A and B (0.25 kW ... 2.2 kW)

The RFI filter reduces mains-bound noise emission into the mains network, thus ensuring that threshold class A or B is satisfied. The filter does not replace the function of the mains choke. In order to reduce the r.m.s. current it is also necessary to install an additional mains choke. The structure of the RFI filters enables them to be mounted below or next to the 8200 vector.

Three different types of filter are available:

- **RFI filters LL (Low Leakage)** with leakage current < 3.5 mA for 5 m motor cable for 230 V/1 ph are used for installation in non-fixed systems
- **SD RFI filter** (Short Distance) with low leakage current, e.g. for use on a 30 mA fault current protection switch
- **LD RFI filter** (Long Distance) for use with long motor cables

Important: Only use the RFI filters in conjunction with the 8200 vector, types E82EVxxxKxC200.

8200 vector			RFI filter A/B, dimensions [mm]									
Type	Voltage [V]	Power [kW]	Order ref.	a	a ₁	a ₂	b	b ₁	b ₂	b ₃	c	Weight [kg]
E82xV251K2C200	1~ 230	0.25	LL: E82ZZ37112B220	60	25	10	217	197	172	135	30	0.5
E82xV371K2C200		0.37	SD: E82ZZ37112B200 LD: E82ZZ37112B210									
E82xV551K2C200		0.55	LL: E82ZZ75112B220									
E82xV751K2C200		0.75	SD: E82ZZ75112B200 LD: E82ZZ75112B210									
E82xV152K2C200		1.5	SD: E82ZZ22212B200									
E82xV222K2C200		2.2	LD: E82ZZ22212B210									
E82xV551K2C200	3~ 230	0.55	SD: E82ZZ75132B200	60	25	10	277	247	232	195	40	0.8
E82xV751K2C200		0.75	LD: E82ZZ75132B210									
E82xV152K2C200		1.5	SD: E82ZZ22232B200									
E82xV222K2C200		2.2	LD: E82ZZ22232B210									
E82xV551K4C200	3~ 400/500	0.55	SD: E82ZZ75134B200	60	25	10	277	247	232	195	40	0.8
E82xV751K4C200		0.75	LD: E82ZZ75134B210									
E82xV152K4C200		1.5	SD: E82ZZ22234B200									
E82xV222K4C200		2.2	LD: E82ZZ22234B210									

Note:

- The maximum permissible motor cable lengths for conformance with threshold class A or B can be found on page 4-14.
- The 8200 vector is installed on the footprint RFI filter using the standard fixtures included in the scope of supply of the frequency inverter.
- The RFI filters comply with the UL/cUL requirements (in preparation).

Schematic diagram (example: 1~ 230 V)

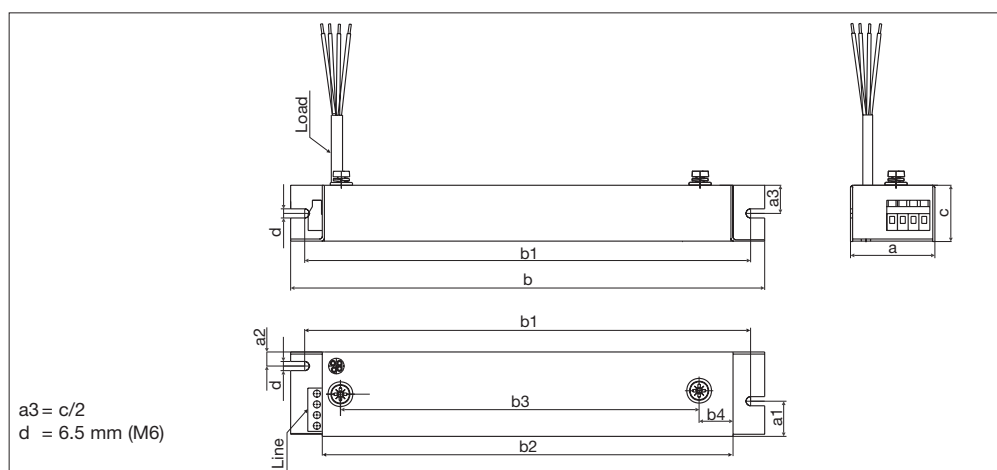

Terminal assignment

Input (mains):

PE	N	L1		1~ 230 V

PE	L1	L2	L3	3~ 230 V or 3~ 400 V

Output (load):

PE, N, L1 (1~ 230 V)
PE, L1, L2, L3 (3~ 230 V or
3~ 400 V)

Footprint RFI filters threshold class A and B (3.0 kW ... 11 kW)

8200 vector			RFI filter A/B, dimensions [mm]									
Type	Voltage [V]	Power [kW]	Order ref.	a	a ₁	a ₂	b	b ₁	b ₂	b ₃	c	Weight [kg]
E82xV302K2C200	3~ 230	3.0	SD: E82ZZ40232B200	100	12.5	75	337	317	292	255	60	1.7
E82xV402K2C200		4.0	LD: E82ZZ40232B210									
E82xV552K2C200		5.5	SD: E82ZZ75232B200	125	25	75	337	317	292	255	60	
E82xV752K2C200		7.5	LD: E82ZZ75232B210									
E82xV302K4C200	3~ 400/500	3.0	SD: E82ZZ55234B200	100	12.5	75	337	317	292	255	60	1.7
E82xV402K4C200		4.0	LD: E82ZZ55234B210									
E82xV552K4C200		5.5										
E82xV752K4C200		7.5	SD: E82ZZ11334B200	125	25	75	337	317	292	255	60	
E82xV113K4C200		11.0	LD: E82ZZ11334B210									

Note:

- The maximum permissible motor cable lengths for conformance with threshold class A or B can be found on page 4-14.
- The 8200 vector is installed on the footprint RFI filter using the standard fixtures included in the scope of supply of the frequency inverter.
- The RFI filter comply with the UL/cUL requirements (in preparation).

Schematic diagram

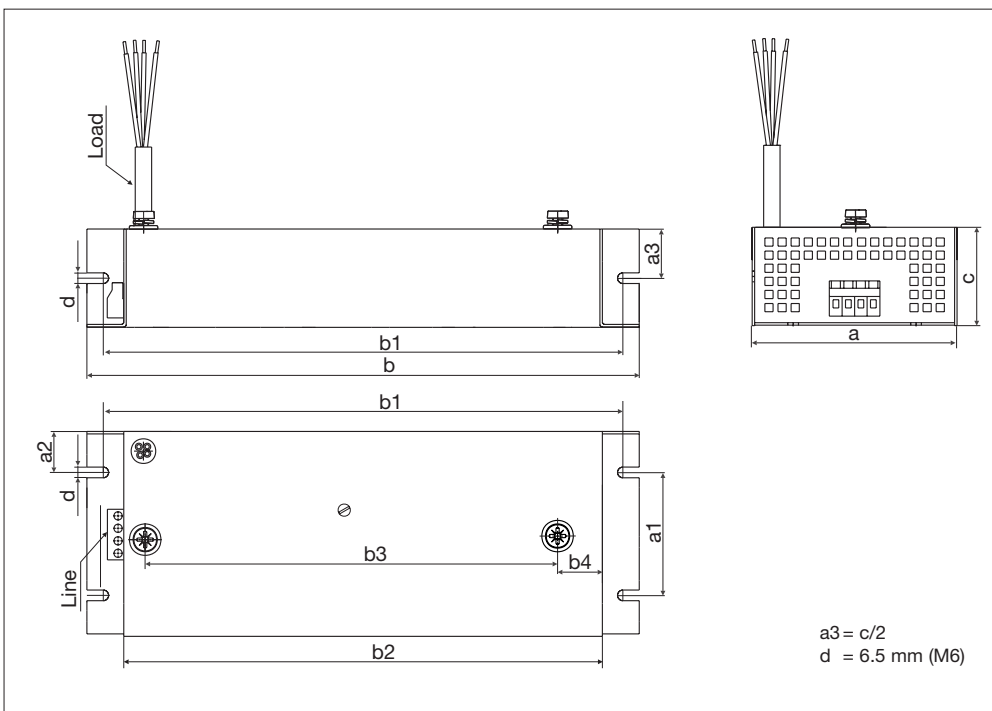

Terminal assignment

Input (mains):

PE	L1	L2	L3

Output (load):

PE, L1, L2, L3



Footprint mains filters threshold class A and B (15 kW ... 90 kW)

Mains filter A

A mains filter is a combination of mains choke and RFI filter in one housing. It reduces line-bound noise emission into the mains network, thus ensuring that threshold class A/B is satisfied. In addition, a mains filter replaces the function of a mains choke. The r.m.s. current is also reduced.

Important:

- Only use the mains filters in conjunction with the 8200 vector, types E82EVxxxKxB201.
- When mounting the 8200 vector according to the “push-through technique” or “cold plate” technology, only integrated mains filters can be used for interference suppression.

Selection for operation at rated power (normal operation)

8200 vector			Mains filter A/B, dimensions [mm]									
Type	Voltage [V]	Power [kW]	Order ref.	a	a1	b	b1	e	e1	e2	m	Weight [kg]
E82EV153K4B201	3~ 400/500 V	15.0	E82ZN22334B230	235.5	231	410	350	110	90	11.5	M5	13
E82EV223K4B201		22.0	E82ZN22334B230			430						
E82EV303K4B201		30.0	E82ZN30334B230			430						
E82EV453K4B201		45.0	E82ZN45334B230	318	313.5	580	500	114	90	14.5	M8	26
E82EV553K4B201		55.0	E82ZN55334B230	428	423.5	685	590					29
E82EV753K4B201		75.0	E82ZN75334B230			760	670					53
E82EV903K4B201		90.0	E82ZN90334B230			765	670					53

Note:

- The maximum permissible motor cable lengths for conformance with threshold class A or B can be found on page 4-14.
- The 8200 vector is installed on the footprint mains filter using the standard fixtures included in the scope of supply of the frequency inverter. (see page 2-36)
- The assignment of footprint mains filters for operation with increased rated power can be found on page 4-56.
- The mains filter comply with the UL/cUL requirements (in preparation).

Schematic diagram

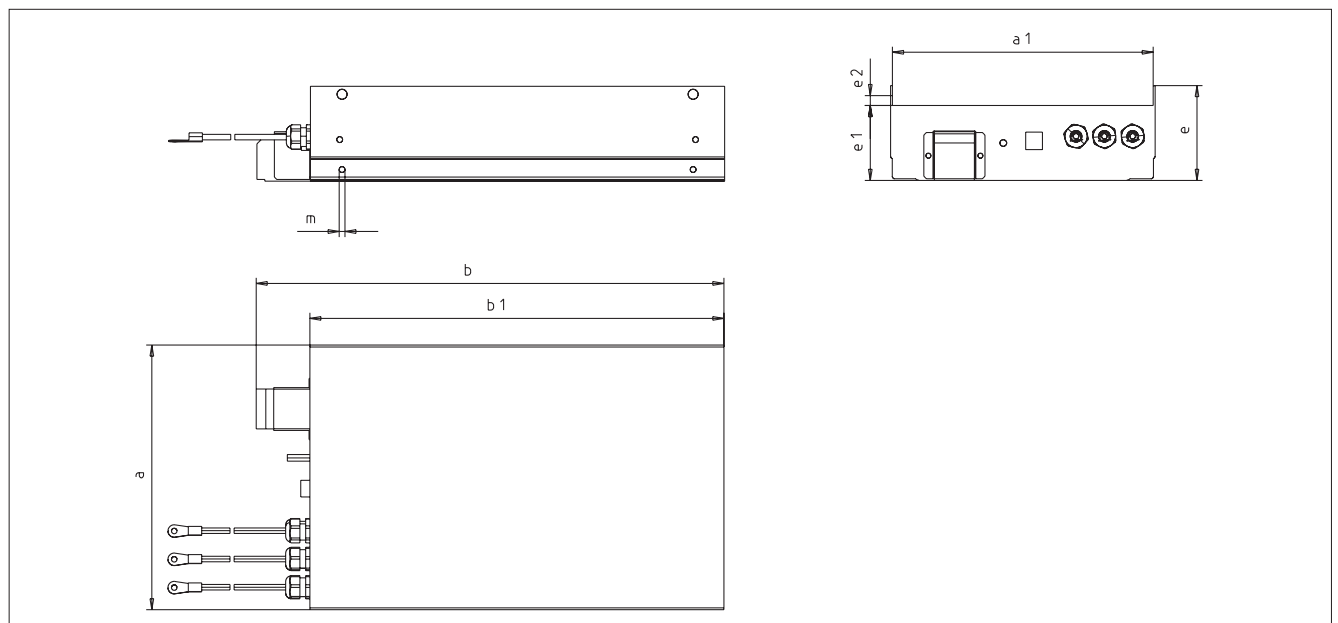

Built-on mains filters threshold class A (15 kW ... 90 kW)

Mains filter A

A mains filter is a combination of mains choke and RFI filter in one housing. It reduces line-bound noise emission into the mains network, thus ensuring that threshold class A is satisfied. In addition, a mains filter replaces the function of a mains choke. The r.m.s. current is also reduced.

Important:

- Only use the mains filters in conjunction with the 8200 vector, types E82EVxxxKxB201.
- When mounting the 8200 vector according to the “push-through technique” or “cold plate” technology only integrated mains filters can be used for interference suppression.

Selection for operation at rated power (normal operation)

8200 vector	Mains filter A				
	Type	Order ref.	I_r [A]	Inductance [mH]	U_{mains} [V]
E82xV153K4B201	EZN3A0110H030	30.0	1.1	400...480	16.0
E82xV223K4B201	EZN3A0080H042	42.0	0.8	400...480	17.0
E82xV303K4B201	EZN3A0055H060	60.0	0.55	400...480	30.0
E82xV453K4B201	EZN3A0037H090	90.0	0.37	400...480	40.0
E82xV553K4B201	EZN3A0030H110	110.0	0.30	400...480	46.0
E82xV753K4B201	EZN3A0022H150	150.0	0.22	400...480	60.0
E82xV903K4B201	EZN3A0017H200	200.0	0.17	400...480	90.0

Selection for operation at increased rated power

8200 vector	Mains filter A				
	Type	Order ref.	I_r [A]	Inductance [mH]	U_{mains} [V]
E82xV153K4B201	EZN3A0080H042	42.0	0.8	400...480	17
E82xV223K4B201	EZN3A0055H060	60.0	0.55	400...480	30
E82xV303K4B201	EZN3A0055H060	60.0	0.55	400...480	30
E82xV453K4B201	EZN3A0030H110	110.0	0.30	400...480	46
E82xV553K4B201	-	-	-	-	-
E82xV753K4B201	EZN3A0022H150	150.0	0.22	400...480	60
E82xV903K4B201	EZN3A0017H200	200.0	0.17	400...480	90



Built-on mains filters threshold class B (15 kW ... 90 kW)

Mains filter B

A mains filter is a combination of mains choke and RFI filter in one housing. It reduces line-bound noise emission into the mains network, thus ensuring that threshold class B is satisfied. In addition, a mains filter replaces the function of a mains choke. The r.m.s. current is also reduced.

Important:

- Only use the mains filters in conjunction with the 8200 vector, types E82EVxxxKxB201.
- When mounting the 8200 vector according to the “push-through technique” or “cold plate” technology, only integrated mains filters can be used for interference suppression.

Selection for operation at rated power (normal operation)

8200 vector	Mains filter B				
Type	Order ref.	I_r [A]	Inductance [mH]	U_{mains} [V]	Weight [kg]
E82xV153K4B201	EZN3B0110H030	30.0	1.10	400...480	20
E82xV223K4B201	EZN3B0080H042	42.0	0.80	400...480	20
E82xV303K4B201	EZN3B0055H060	60.0	0.55	400...480	32
E82xV453K4B201	EZN3B0037H090	90.0	0.37	400...480	42
E82xV553K4B201	EZN3B0030H110	110.0	0.33	400...480	50
E82xV753K4B201	EZN3B0022H150	150.0	0.22	400...480	65
E82xV903K4B201	EZN3B0017H200	200.0	0.17	400...480	95

Selection for operation at increased rated power

8200 vector	Mains filter B				
Type	Order ref.	I_r [A]	Inductance [mH]	U_{mains} [V]	Weight [kg]
E82xV153K4B201	EZN3B0080H042	42.0	0.8	400...480	20
E82xV223K4B201	EZN3B0055H060	60.0	0.55	400...480	32
E82xV303K4B201	EZN3B0055H060	60.0	0.55	400...480	32
E82xV453K4B201	EZN3B0030H110	110.0	0.30	400...480	50
E82xV553K4B201	–	–	–	–	–
E82xV753K4B201	EZN3B0022H150	150.0	0.22	400...480	65
E82xV903K4B201	EZN3B0017H200	200.0	0.17	400...480	95

Dimensions for standard mounting

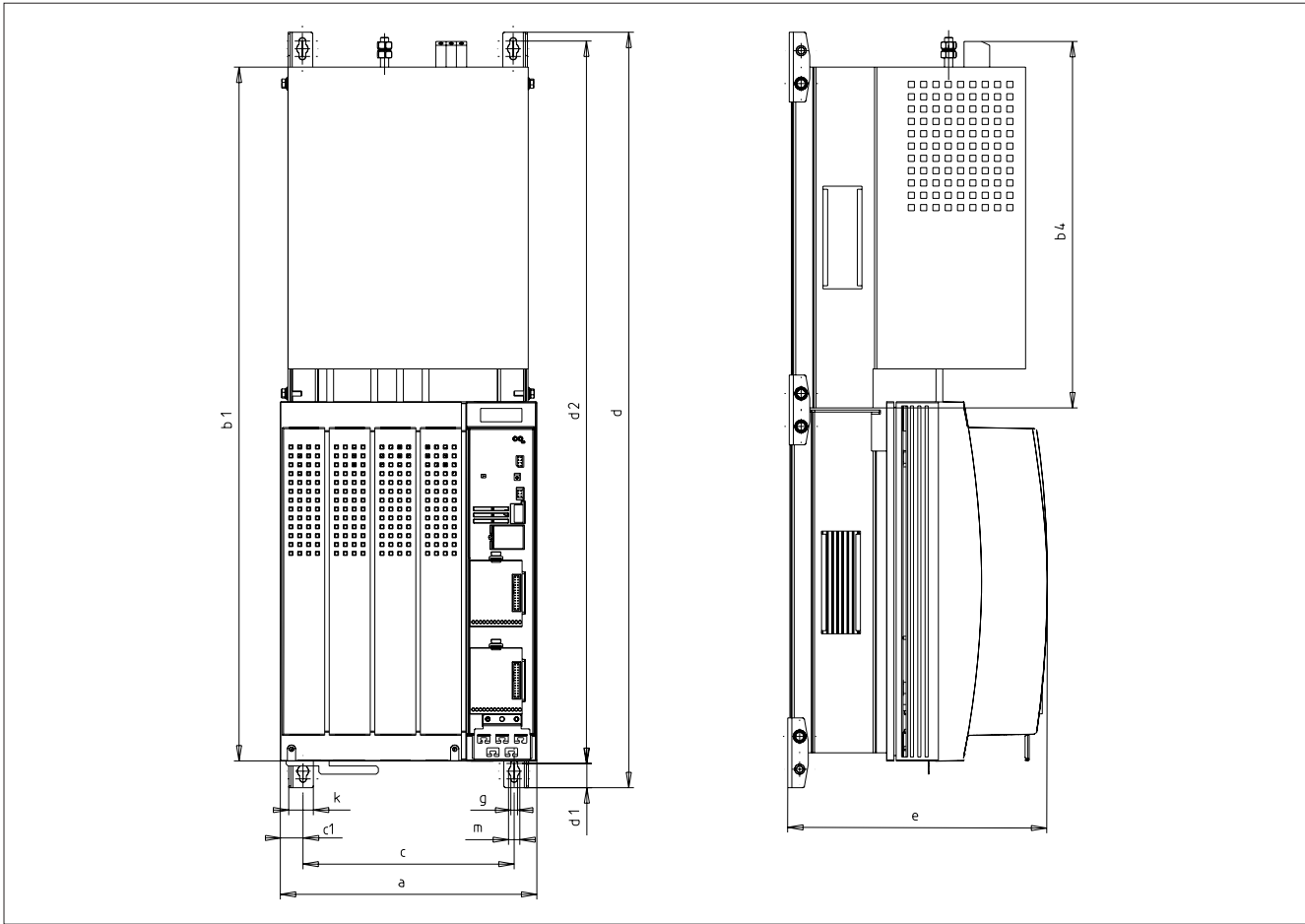

Clearance of 100 mm above/50 mm to the side.

Mains filter A or B	Dimensions [mm]											
Order ref.	a	b1	b4	c	c1	d	d1	d2	e	g	k	m
EZN3x0110H030	250	680	365	205	22	740	24	705	250	6.5	24	11
EZN3x0080H042									285			
EZN3x0055H060									285			
EZN3x0037H090	340	973	508	284	28	1050	38	1000	285	11	28	18
EZN3x0030H110												

Note:
The mains filter has an adapted connecting cable.

Dimensions for mounting next to the frequency inverter

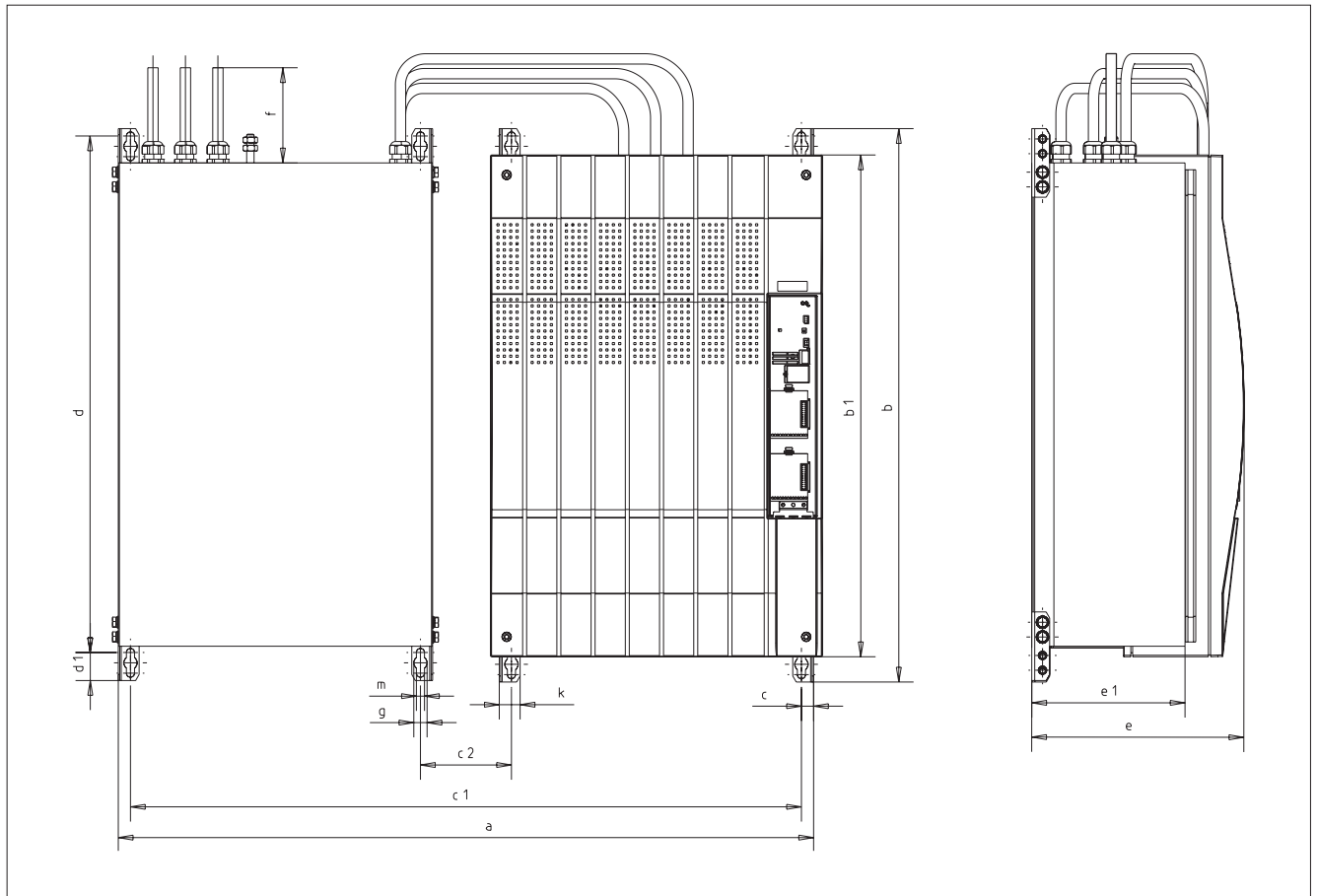

Clearance of 150 mm above and below/100 mm to the side.

Mains filter A or B	Dimensions [mm]													
Order ref.	a	b	b1	c	c1	c2	d	d1	e	e1	f	g	k	m
EZN3x0022H150	1000	750	680	16	970	180	702	38	285	207.5	1000	18	28	11
EZN3x0017H200														

Note:

The mains filter has an adapted connecting cable.

Dimensions for mounting using footprint technology

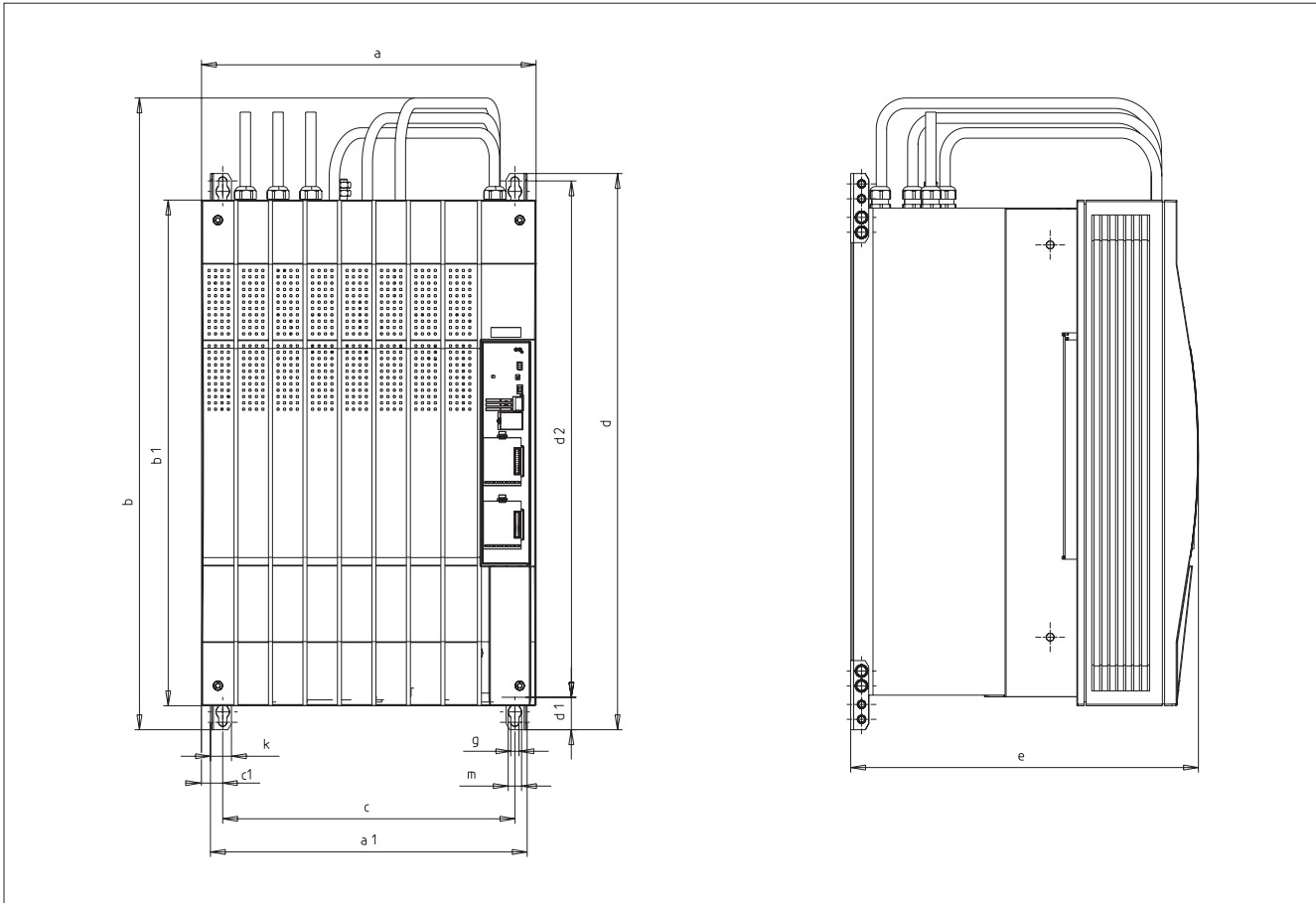

Clearance of 150 mm above and below/100 mm to the side.

Mains filter A or B	Dimensions [mm]													
Order ref.	a	a1	b	b1	c	c1	d	d1	d2	e	f	g	k	m
EZN3x0022H150	450	428	800	680	395	30,5	750	38	702	470	1000	11	28	18
EZN3x0017H200														

Note:
The mains filter has an adapted connecting cable.

General information

Motor filters should be used to reduce the load on the motor windings, as well as to reduce the capacitive leakage currents to PE that may be caused by the use of long motor cables.

A motor filter is required:

- if very long motor cables are used (in addition to conforming with EMC limit values).
- in conjunction with LD RFI filters (0.25...11.0 kW) for the reduction of line-bound noise emission, if very long motor cables are used in order to conform with EMC threshold class A or B (see page 4-14).
- if motors are used with an insulation system not suited for inverter operation. Lenze motors feature insulation with a high thermal reserve.

Motor filters ensure the reliable operation of the 8200 vector with motor cable lengths of up to 200 m.

Please note:

- The voltage drop at the motor filter at the rated current of the motor filter and a frequency inverter of 50 Hz is typically around 2-3% of the max. output voltage of the 8200 vector.
- If present, terminals +UG and -UG must be connected with the same cable cross-section as the motor cable.

Motor filter connection

Schematic diagram for the 8200 vector, 230 V

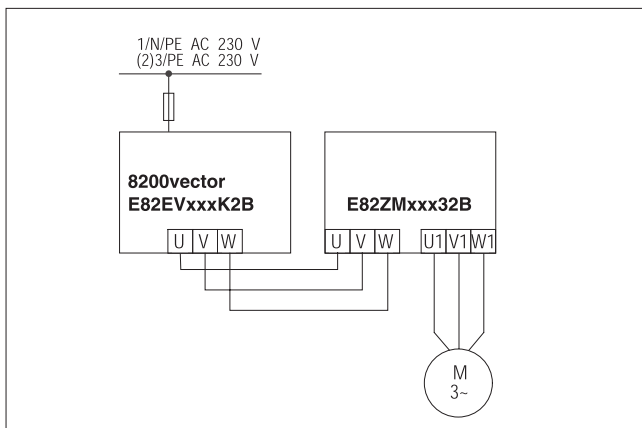

Schematic diagram for the 8200 vector, 400/500V¹⁾

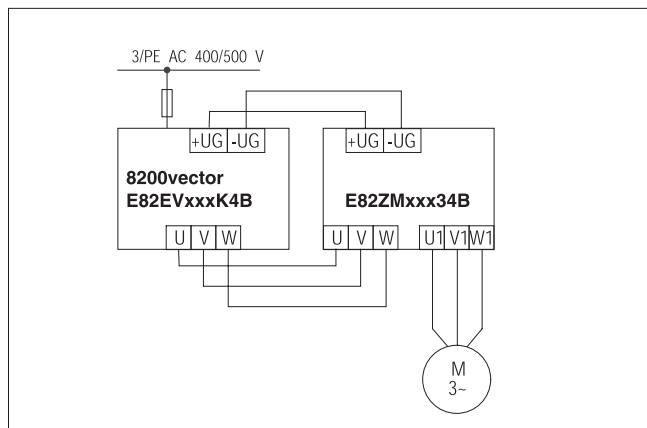

¹⁾ Motor filters with 400/500 V mains voltage: In order to maintain the specified characteristics (e.g. limitation of the overvoltage), the voltage increases on the motor cable are routed via the motor filter to the DC bus of the 8200 vector (+UG, -UG). In this case, it is permissible for the motor filter to be used in DC bus operation.

General data and application conditions for motor filters used with the 8200 vector (0.25 ... 11.0 kW)

Motor filter always required a motor cable length of	<ul style="list-style-type: none"> • 50 m shielded (low-capacitance) • 100 m unshielded ¹⁾
Max. motor cable length	<ul style="list-style-type: none"> • 100 m shielded (low-capacitance) • 200 m unshielded ¹⁾
Protection of the motor coil	$du/dt \leq 500 \text{ V}/\mu\text{s}$
Limitation of motor overvoltage	$< 1 \text{ kV}$
Max. mains voltage	264 V +0% or 550 V +0%
Temperature range	0...40°C
Connection type	Contact-proof screw terminals
Degree of protection	IP 20
Operating conditions for the 8200 vector in conjunction with a motor filter	<ul style="list-style-type: none"> • Maximum output frequency: 480 Hz • Maximum operating frequency: 8 kHz • Operating mode: V/f characteristic control (linear or quadratic)

¹⁾ When using unshielded motor cables, only line-bound noise emission EMC requirements have to be met



Motor filter (0.25 ... 2.2 kW/230 V)

8200 vector			Motor filter, dimensions [mm]								Weight [kg]
Type	Voltage [V]	Power [kW]	Order ref.	a	a ₁	a ₂	b	b ₁	b ₂	c	
E82EV251K2C	1~ 230	0.25	E82ZM22232B	60	25	10	220	200	180	140	3.6
E82EV371K2C		0.37									
E82EV551K2C		0.55									
E82EV751K2C		0.75									
E82EV152K2C		1.5									
E82EV222K2C		2.2									
E82EV551K2C	3~ 230	0.55									
E82EV751K2C		0.75									
E82EV152K2C		1.5									
E82EV222K2C		2.2									

Schematic diagram

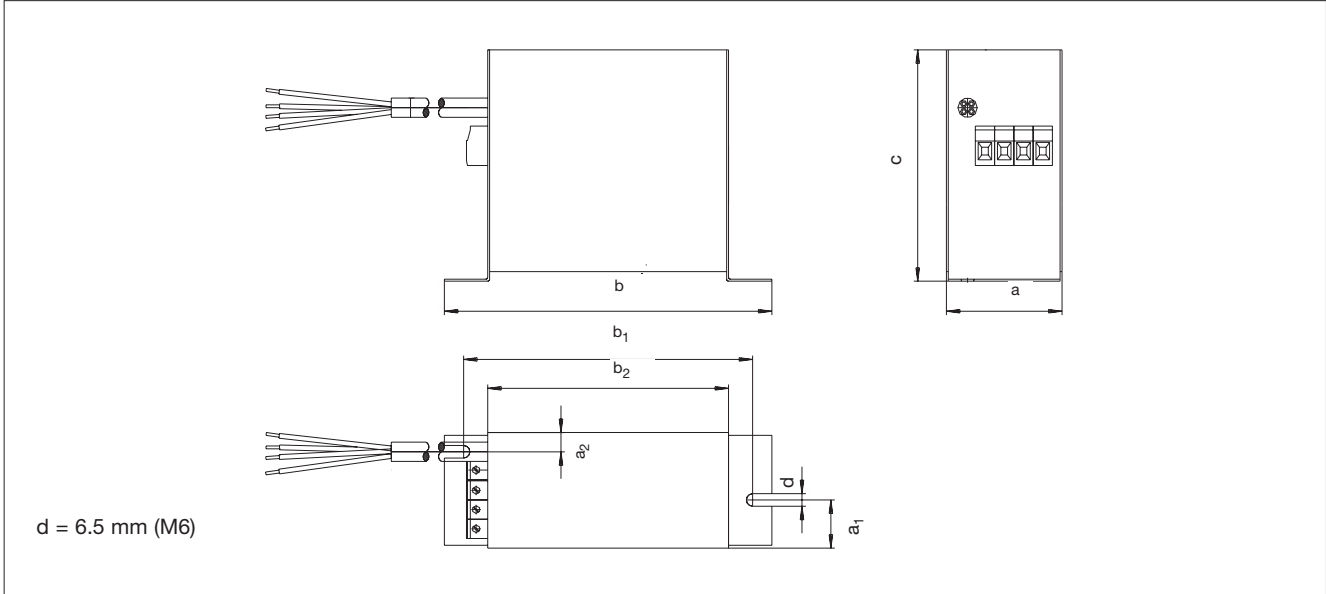

Note:

On shielded motor cables the shielding should be applied to a large area of the mounting plate.

Terminal assignment

Input (pre-assembled cable):

PE, U, V, W

Output:

PE	U1	V1	W1



Accessories

Motor filters

Motor filter (0.55 ... 2.2 kW/400 V)

8200 vector			Motor filter, dimensions [mm]								
Type	Voltage [V]	Power [kW]	Order ref.	a	a ₁	b	b ₁	b ₂	c	c ₁	Weight [kg]
E82EV551K4C	3~ 400	0.55	E82ZM75134B	67	33.5	200	175	160	130	17	2.2
E82EV751K4C		0.75									
E82EV152K4C		1.5	E82ZM22234B020								2.3
E82EV222K4C		2.2									

Schematic diagram

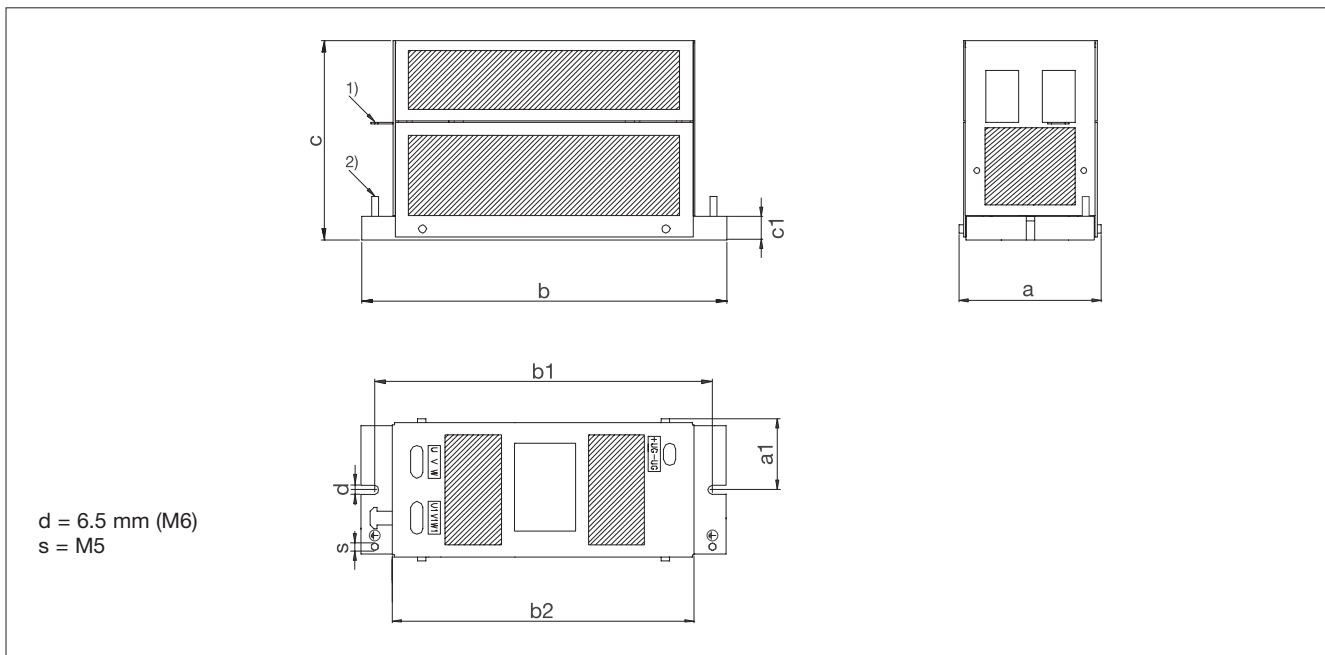

1) Shield for motor cable (tip: use cable ties to support the shielding)

2) Earthing stud (M5) for PE connection

Note:

If the cables between the frequency inverter and the motor filter (U, V, W/+UG, -UG) < 20 cm, they can be routed without shielding.

Motor filter (3.0 ... 11.0 kW/400 V)

8200 vector			Motor filter, dimensions [mm]									
Type	Voltage [V]	Power [kW]	Order ref.	a	a ₁	a ₂	b	b ₁	b ₂	c	c ₁	Weight [kg]
E82EV302K2C	3~ 230	3.0	E82ZM75234B	127	26	75	300	275	257	150	17	5.4
E82EV402K2C		4.0										
E82EV552K2C		5.5	E82ZM11334B									
E82EV752K2C		7.5										
E82EV302K4C	3~ 400	3.0	E82ZM40234B	106	28	50	270	250	223	150	17	3.6
E82EV402K4C		4.0										
E82EV552K4C		5.5	E82ZM75234B									
E82EV752K4C		7.5										
E82EV113K4C		11.0	E82ZM11334B									

Schematic diagram

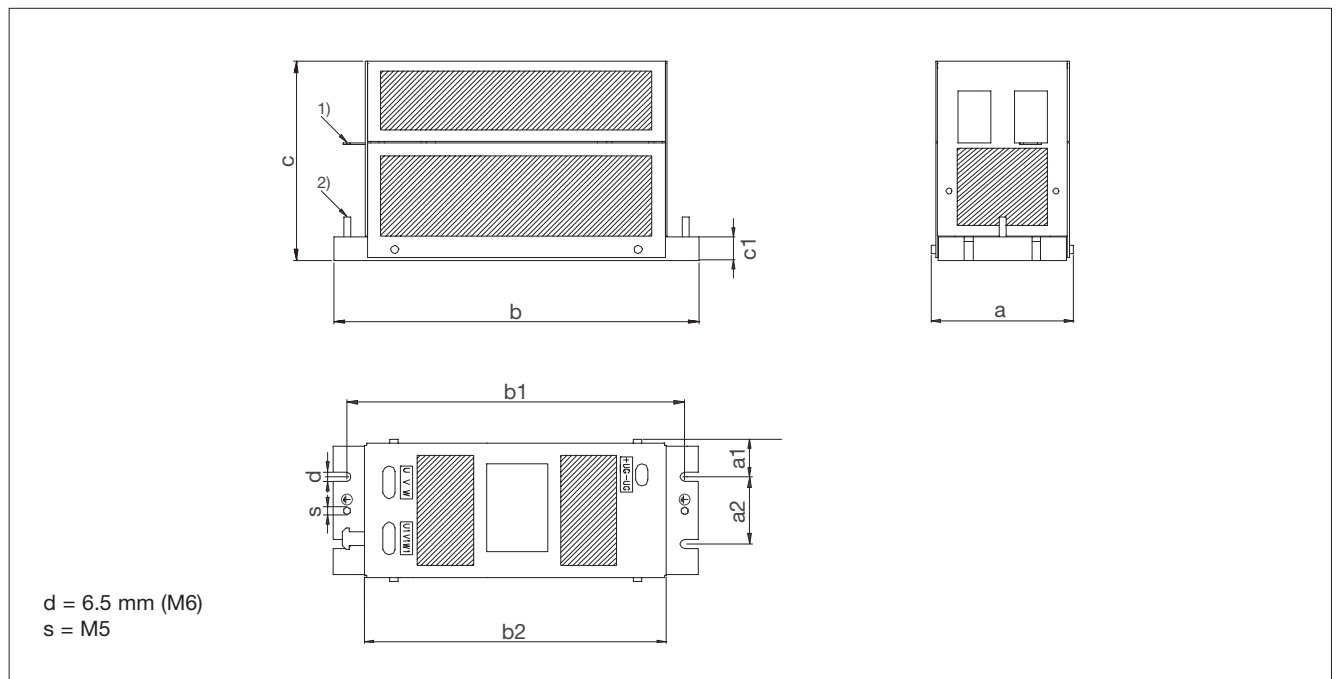

- 1) Shield for motor cable (tip: use cable ties to support the shielding)
- 2) Earthing stud (M5) for PE connection

Note:

If the cables between the frequency inverter and the motor filter (U, V, W/+UG, -UG) < 20 cm, they can be routed without shielding.

Motor filters (15.0 kW ... 22.0 kW/400 V)

A motor filter is always required from a motor cable length of	<ul style="list-style-type: none"> • 50 m shielded • 100 m unshielded
Max. motor cable length	<ul style="list-style-type: none"> • 100 m shielded • 200 m unshielded
Protection of motor winding	$du/dt \leq 500 \text{ V}/\mu\text{s}$
Limitation of motor overvoltage	< 1 kV
Max. mains voltage	500 V +0%
Temperature range	0...40 °C
Connection type	Protected screw terminals
Degree of protection	IP20
Operating conditions for 8200 vector in combination with motor filter	<ul style="list-style-type: none"> • Maximum output frequency: 300 Hz • Maximum chopper frequency: 4 kHz • Operating mode: V/f characteristic control (linear or square)

Note:

The frequency inverter is also loaded with approx. 12% of the motor filter rated current.

Selection and dimensions for operation at rated power (normal operation)

8200 vector		Motor filter, dimensions [mm]						
Type	Voltage [V]	Order ref.	a	a ₁	b	b ₁	c	Weight [kg]
E82EV153K4B201	3~ 400	ELM3-004H055 ¹⁾	235	220	500	400	185	40
E82EV223K4B201								

¹⁾ Current rating: 55 A

Selection and dimensions for operation with increased power rating

8200 vector		Motor filter, dimensions [mm]						
Type	Voltage [V]	Order ref.	a	a ₁	b	b ₁	c	Weight [kg]
E82EV153K4B201	3~ 400	ELM3-004H055 ¹⁾	235	220	500	400	185	40

Schematic diagram

Terminal assignment

Input:

-UG	+UG	W	V	U	PE

Output:

W1	V1	U1	PE

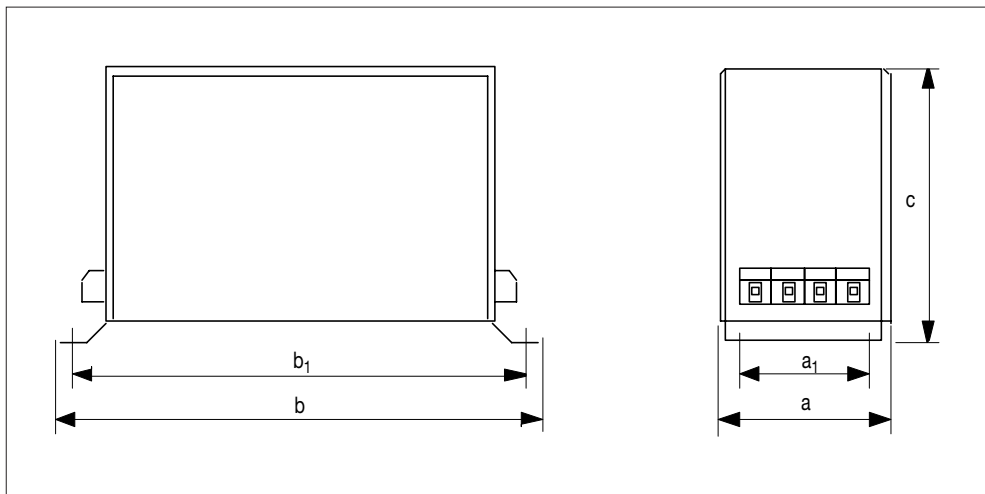



General information

External brake resistors are required to brake high moments of inertia or for extended generator mode operation. The brake resistor converts mechanical braking energy into heat.
The brake transistor (0.25 ... 11.0 kW) integrated in the 8200 vector frequency inverter or the corresponding brake

chopper connects the external brake resistor when the DC bus voltage exceeds a certain switching threshold. This prevents the frequency inverter from setting a pulse inhibit because of an overvoltage, which would cause the drive to coast to standstill. Braking is always controlled when using an external brake resistor.

Selection of brake resistors

The Lenze brake resistors recommended in the tables are appropriate for each frequency inverter (related to approx. 150% generative power). They are suitable for most applications.

For special applications, e.g. centrifuges, materials handling systems etc., the suitable brake resistor must meet the following requirements:

Brake resistor requirement	Application	
	with active load	with passive load
Continuous power [W]	$\geq P_{\max} \cdot \eta_e \cdot \eta_m \cdot \frac{t_1}{t_{\text{cycl}}}$	$\geq \frac{P_{\max} \cdot \eta_e \cdot \eta_m}{2} \cdot \frac{t_1}{t_{\text{cycl}}}$
Thermal capacity [Ws]	$\geq P_{\max} \cdot \eta_e \cdot \eta_m \cdot t_1$	$\geq \frac{P_{\max} \cdot \eta_e \cdot \eta_m}{2} \cdot t_1$
Resistance [Ω]	$R_{\min} \leq R \leq \frac{U_{\text{DC}}^2}{P_{\max} \cdot \eta_e \cdot \eta_m}$	

- Active load Can move by itself without any influence from the drive (e.g. materials handling systems, unwinders)
- Passive load Stops by itself without any influence from the drive (e.g. horizontal traversing drives, centrifuges, fans)
- U_{DC} [V] Threshold for brake transistor or brake chopper
- P_{\max} [W] Maximum braking power defined by the application
- η_e Electrical efficiency (frequency inverter + motor)
Guide values: 0.54 (0.25 kW) ... 0.95 (90 kW)
- η_m Mechanical efficiency (gearbox, machine)
- t_1 [s] Braking time
- t_{scan} [s] Cycle time = time between two subsequent braking cycles (= t_1 + break time)
- R_{\min} Smallest permissible brake resistance (see rating for the integrated brake transistor)

Integrated brake transistors (0.25 kW ... 7.5 kW/230 V)

Brake transistor		8200 vector, 230 V					
		E82EV 251K2C	E82EV 371K2C	E82EV 551K2C	E82EV 751K2C	E82EV 152K2C	E82EV 222K2C
Threshold U_{DC}	[V DC]	380					
Peak braking power	[A DC]	0.85		4.0		8.6	
Max. continuous current	[A DC]	0.85		2.0		5.8	
Smallest permissible brake resistance	[Ω]	470		90		47	
Current derating		<ul style="list-style-type: none"> over 40°C, derate the peak braking power by 2.5%/°C over 1000 m above sea level, derate the peak braking power by 5%/1000 m 					
Switch-on cycle		Max. 60 s peak brake current, then at least 60 s recovery time					
Recommended Lenze brake resistor ¹⁾	Order ref.	ERBM470R020W		ERBM200R100W		ERBM082R150W	ERBM052R200W

Brake transistor		8200 vector, 230 V			
		E82EV302K2C	E82EV402K2C	E82EV552K2C	E82EV752K2C
Threshold U_{DC}	[V DC]	380			
Peak braking power	[A DC]	13.0	13.0	20.0	20.0
Max. continuous current	[A DC]	8.0	10.7	14.7	20.0
Smallest permissible brake resistance	[Ω]	29	29	19	19
Current derating		<ul style="list-style-type: none"> over 40°C, derate the peak braking power by 2.5%/°C over 1000 m above sea level, derate the peak braking power by 5%/1000 m 			
Switch-on cycle		Max. 60 s peak brake current, then at least 60 s recovery time			
Recommended Lenze brake resistor ¹⁾	Order ref.	ERBD047R01K2	ERBD047R01K2	ERBD047R01K2	ERBD047R01K2

¹⁾ The brake resistors are based on a switch-on cycle of 1:10
(max. 15 s braking, then at least 150 s recovery time)



Integrated brake transistors (0.55 kW ... 11.0 kW/400 V)

Brake transistor		8200 vector, 400 V			
		E82EV551K4C	E82EV751K4C	E82EV152K4C	E82EV222K4C
Threshold U_{DC}	[V DC]	790 (adjustable)			
Peak braking power	[A DC]	1.9		3.8	5.6
Max. continuous current	[A DC]	0.96		1.92	2.8
Smallest permissible brake resistance ($U_{DC} = 790$ V)	[Ω]	455		230	155
Current derating		<ul style="list-style-type: none"> • over 40°C, derate the peak braking power by 2.5%/°C • over 1000 m above sea level, derate the peak braking power by 5%/1000 m 			
Switch-on cycle		Max. 60 s peak brake current, then at least 60 s recovery time			
Recommended Lenze brake resistor ¹⁾	Order ref.	ERBM470R100W		ERBM370R150W	ERBM240R200W

Brake transistor		8200 vector, 400 V				
		E82EV302K4C	E82EV402K4C	E82EV552K4C	E82EV752K4C	E82EV113K4C
Threshold U_{DC}	[V DC]	790 (adjustable)				
Peak braking power	[A DC]	7.8	7.8	11.4	16.5	23.5
Max. continuous current	[A DC]	3.9	5.1	7.0	9.6	14.1
Smallest permissible brake resistance ($U_{DC} = 790$ V)	[Ω]	100	100	68	47	33
Current derating		<ul style="list-style-type: none"> • over 40°C, derate the peak braking power by 2.5%/°C • over 1000 m above sea level, derate the peak braking power by 5%/1000 m 				
Switch-on cycle		Max. 60 s peak brake current, then at least 60 s recovery time				
Recommended Lenze brake resistor ¹⁾	Order ref.	ERBD180R300W	ERBD100R600W	ERBD082R600W	ERBD068R800W	ERBD047R01K2

¹⁾ The brake resistors are based on a switch-on cycle of 1:10 (max. 15 s braking, then at least 150 s recovery time)

Brake chopper and brake module (15.0 kW ... 90.0 kW/400 V)

A brake resistor is connected to the 8200 vector frequency inverter, 15.0...90.0 kW via the brake chopper EMB9352-E (available as accessory), which is then coupled to the frequency inverter DC bus voltage (+UG, -UG terminals).

The brake module EMB9351-E (available as an accessory) with integrated brake resistor can be used for low braking power. The brake choppers and brake modules can be connected in parallel in combination.

General data and application conditions (EMB9351-E and EMB9352-E)

Conformity	CE	Low voltage directive (73/23/EEC)
Approvals	UL 508C	Underwriter Laboratories (File No E132659) Power conversion equipment
Vibrational stability	Accelerational stability up to 0.7g (Germanischer Lloyd, general conditions)	
Climatic conditions	Class 3K3 to EN 50178 (without condensation, average relative humidity 85%)	
Pollution degree	VDE 0110 Part 2 pollution degree 2	
Packaging (DIN 4180)	Dust packaging	
Permissible temperature ranges	Transport	-25 °C...+70 °C
	Storage	-25 °C...+70 °C
	Operation	0°C...+55 °C over +40°C derate the rated output current by 2.5%/°C
Permissible installation height	0... 4000 m above sea level over 1000 m above sea level, derate the peak brake current by 5%/1000 m	
Mounting position	Vertical	
Mounting clearances	Above and below	≤ 100 mm

Ratings for the brake chopper (type/order ref. EMB9352-E)

Brake chopper		8200 vector, 400 V						
		E82EV 153K4B201	E82EV 223K4B201	E82EV 303K4B201	E82EV 453K4B201	E82EV 553K4B201	E82EV 753K4B201	E82EV 903K4B201
Threshold U_{DC}	[V DC]	765 (adjustable)						
Peak braking power	[A DC]	42						
Max. continuous current	[A DC]	25						
Smallest permissible brake resistor	[Ω]	18						
Current derating		<ul style="list-style-type: none"> • over 40°C, derate the peak braking power by 2.0%/°C • over 1000 m above sea level, derate the peak braking power by 5%/1000 m 						
Switch-on cycle		Max. 60 s peak brake current, then at least 60 s recovery time						
Recommended Lenze brake resistor	Order ref.	ERBD 033R02K0	ERBD 022R03K0	ERBD 018R03K0	ERBD 022R03K0	ERBD 018R03K0	ERBD 022R03K0	ERBD 018R03K0
Number of brake choppers		1	1	1	2 ¹⁾	2 ¹⁾	3 ¹⁾	3 ¹⁾

¹⁾ Connected in parallel

Ratings for the brake module (type/order ref. EMB9351-E)

Threshold U_{DC}	[V DC]	765 (adjustable)
Peak braking power	[A DC]	16
Peak braking power ($U_{DC} = 765 V$)	[kW]	12
Continuous power	[kW]	0.1
Thermal capacity	[kW s]	50
Switch-on cycle		Max. 4 s peak brake current, then at least 400 s recovery time
Recommended Lenze brake resistor		Integrated (47 Ω)



Fuses and cable cross-sections (EMB9351-E and EMB9352-E)

Type	DC fuse (F4, F5) ¹⁾		Cross-section mm ²	AWG
	VDE	UL		
EMB9351-E EMB9352-E	50 A	40 A K5	6	10

¹⁾ For combinations, where more than two devices (frequency inverters or brake choppers/modules) are coupled to +UG, -UG (parallel connection of brake choppers/modules or bus operation), we recommend providing protection with DC fuses (F4, F5). Please observe national and regional regulations.

Connection

Circuit diagram of a brake chopper

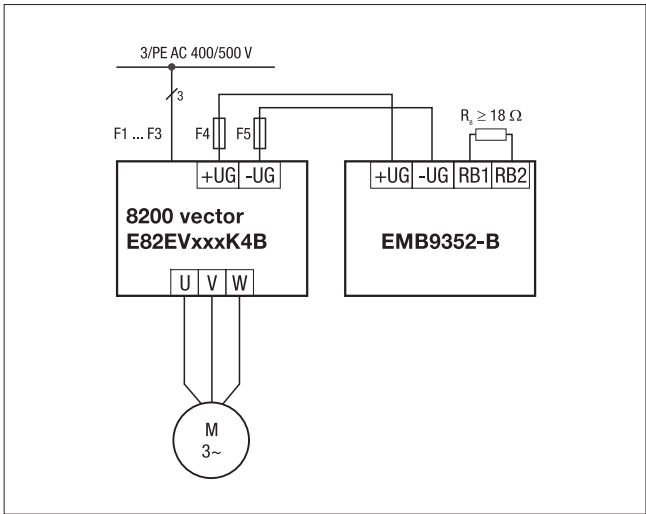

Circuit diagram of a brake module

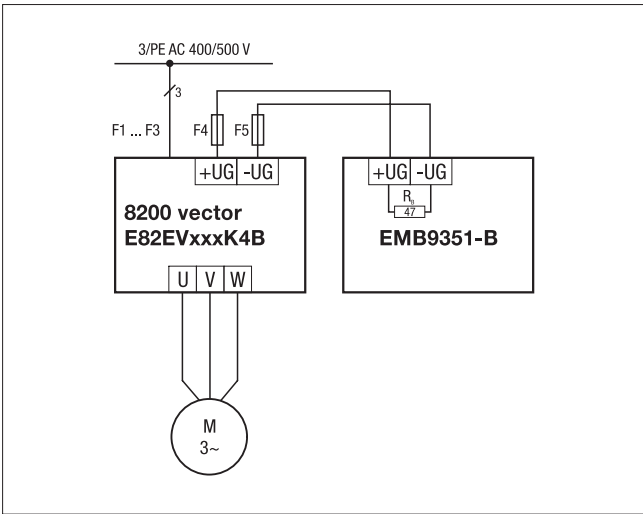

Mounting/dimensions for standard mounting

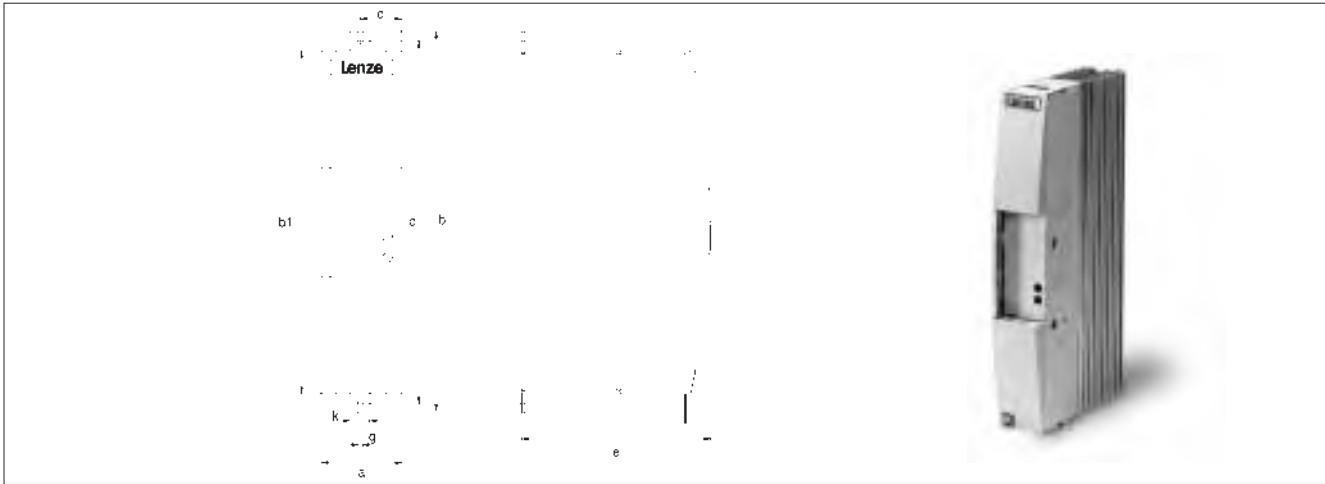

Type	Dimensions [mm]								Weight [kg]
	a	b	b1	c	d	e	g	k	
EMB9351-E	52	384	350	26	365	186	6.5	30	2.6
EMB9352-E									2.2

Mounting/dimensions for "push-through technology"

Mounting/Dimensions for "push-through technology" (thermal separation) The brake chopper/module is mounted according to the "push-through technique" using

a mounting frame and a seal. Both of these can be ordered as an accessory set under the order ref. EJ0040.

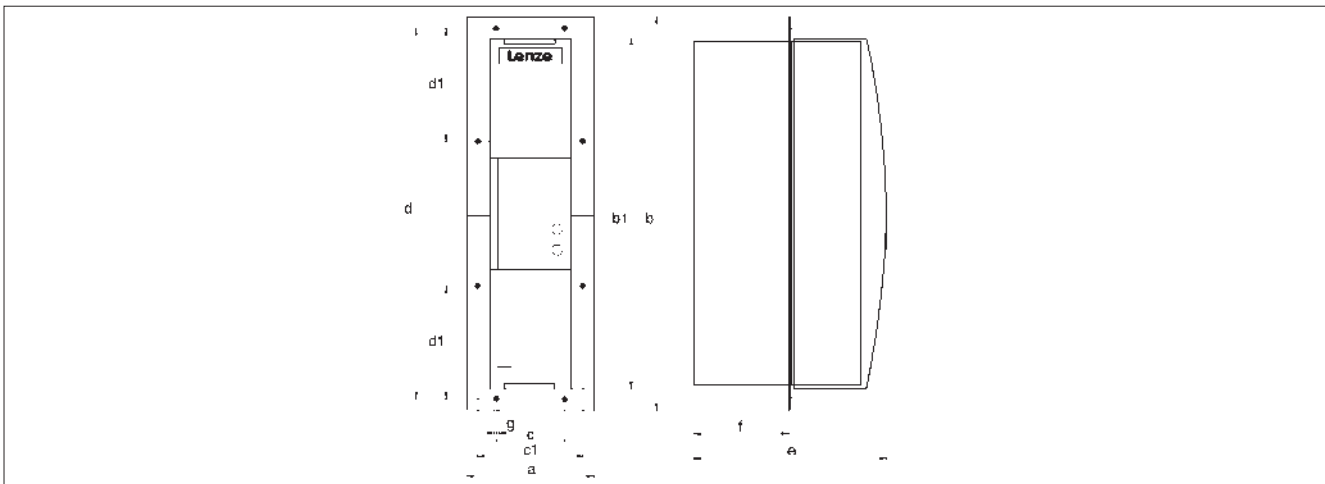

Type	Dimensions [mm]										Weight [kg]
	a	b	b1	c	c1	d	d1	e	f	g	
EMB9351-E	86.5	386	350	34	69.5	367	162.5	186	92	6.5	2.6
EMB9352-E											2.2

Installation section

Type	Dimensions [mm]	
	Height	Width
EMB9351-E	350 ±3	56 ±3
EMB9352-E		



Mounting/dimensions for “cold plate” technology

A brake chopper or brake module in “cold plate” technology.
The order can also be mounted designations are as follows:

- Brake module: EMB9351-C-V003
- Brake chopper: EMB9352-C-V003

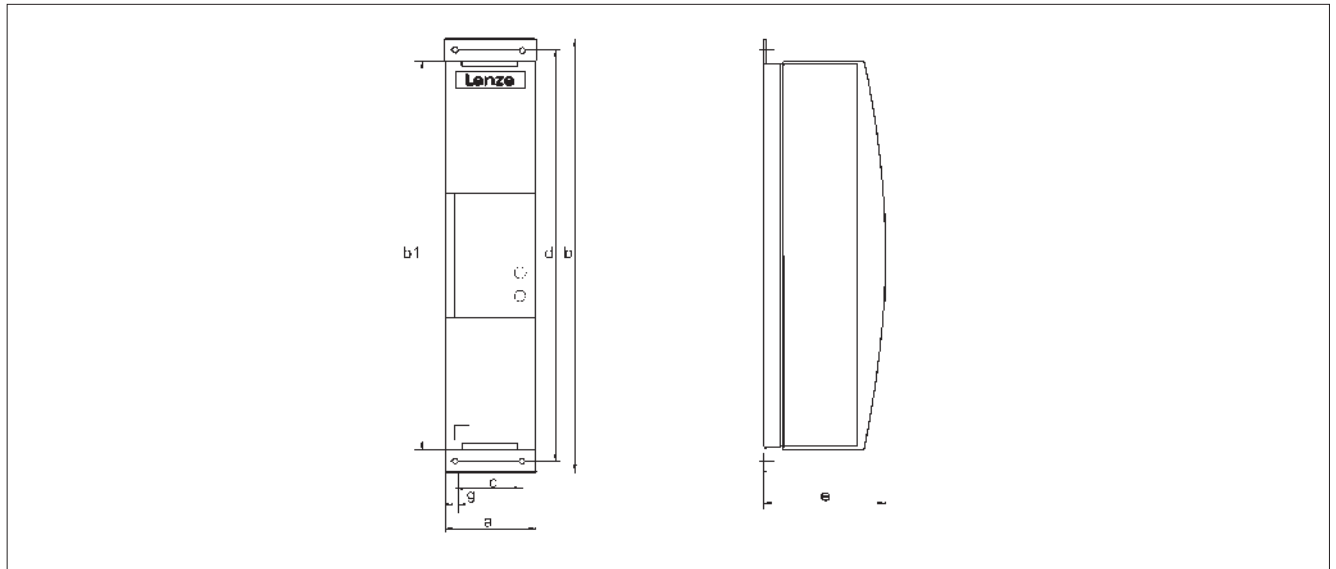

Type	Dimensions [mm]							Weight [kg]
	a	b	b1	c	d	e	g	
EMB9351-C-V003	52	381	350	34	367	104	6.5	2.6
EMB9352-C-V003								2.2

Thermal resistance R_{th} (transition between cooler and cooling medium)

Brake chopper/module		Cooling stretch
Type	Dissipated power loss P_{loss} [W]	R_{th} [K/W]
EMB9351-C-V003	100	≤ 0.3
EMB9352-C-V003	63	≤ 0.3

Additional information about “cold plate” technology can be found on page 2-39.

Brake resistors

Lenze brake resistors (IP 20)							
Order ref.	R	Continuous power ²⁾	Thermal capacity	Switch-on cycle	Cable cross-section		Weight
	[Ω]	[kW]	[kWs]		[mm ²]	AWG	
ERBM470R020W ¹⁾	470	0,02	3,0 ³⁾	1:10 Max. 15 s braking then at least 150 s recovery time	1	18	0,22
ERBM470R050W ¹⁾	470	0,05	7,5		1	18	0,56
ERBM470R100W	470	0,1	15		1	18	0,76
ERBM200R100W ¹⁾	200	0,1	15		1	18	0,6
ERBM370R150W	370	0,15	22,5		1	18	0,93
ERBM100R150W ¹⁾	100	0,15	22,5		1	18	0,93
ERBM082R150W ¹⁾	82	0,15	22,5		1	18	0,93
ERBM240R200W	240	0,2	30		1	18	1,25
ERBM082R200W ¹⁾	82	0,2	30		1	18	1,25
ERBM052R200W ¹⁾	52	0,2	30		1	18	1,25
ERBD180R300W	180	0,3	45		1	18	2,0
ERBD100R600W	100	0,6	90		1	18	3,1
ERBD082R600W	82	0,6	90		1,5	16	3,1
ERBD068R800W	68	0,8	120		1,5	16	4,3
ERBD047R01K2	47	1,2	180		2,5	14	4,9
ERBD033R02K0 ⁴⁾	33	2,0	300		6	10	7,1
ERBD022R03K0 ⁴⁾	22	3,0	450		6	10	10,6
ERBD018R03K0 ⁴⁾	18	3,0	450		6	10	10,6

¹⁾ Only for inverters with mains rated voltage 230 V

²⁾ The continuous power is a reference variable for selecting the brake resistor.
Peak braking power is applied (U_{DC}^2/R).

³⁾ Max. 10 s braking

⁴⁾ In connection with brake module EMB9352-E

Note:

– The brake resistors are fitted with a thermostat (potential-free NC contact) as standard (except ERBM470R020W).

– If required, several brake resistors can be connected in series or in parallel.

(Attention: Do not go below the minimum permissible value!)

Dimensions of module brake resistors ERBM...

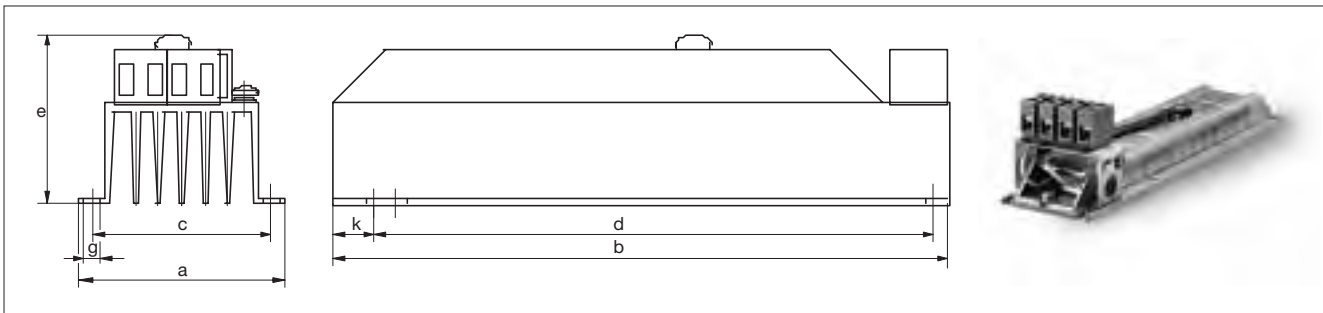

Brake resistor	a [mm]	b [mm]	c [mm]	d [mm]	e [mm]	g [mm]	k [mm]
ERBM470R020W	45	160	–	145	33	6	7.5
ERBM470R050W	60	240	50	225	60	5	7.5
ERBM470R100W	70	240	50	225	60	5	7.5
ERBM200R100W	80	160	70	145	95	5	7.5
ERBM370R150W	80	240	70	225	95	5	7.5
ERBM100R150W	80	240	70	225	95	5	7.5
ERBM082R150W	80	240	70	225	95	5	7.5
ERBM240R200W	80	340	70	325	70	5	7.5
ERBM082R200W	80	340	70	325	70	5	7.5
ERBM052R200W	80	340	70	325	70	5	7.5



Brake resistors

Dimensions – grid enclosed brake resistors ERBD...

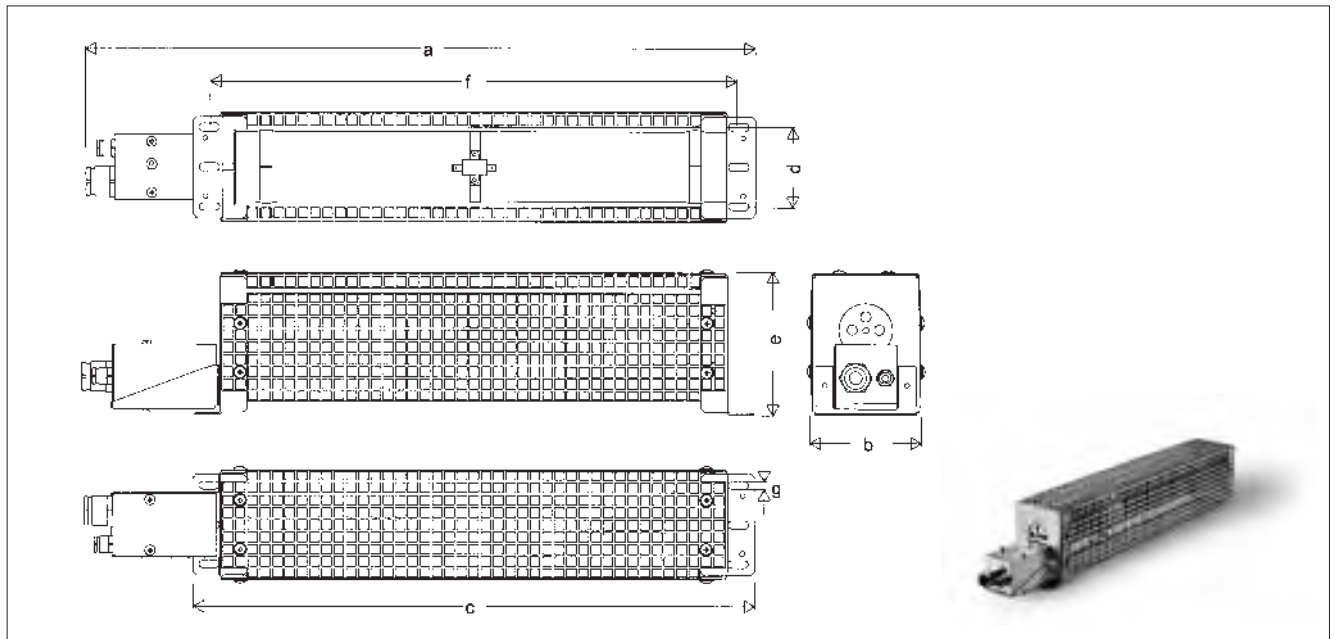

Brake resistor	a [mm]	b [mm]	c [mm]	d [mm]	e [mm]	f [mm]	g [mm]	h [mm]
ERBD180R300W	440	89	354	64	115	326	6.5	13
ERBD100R600W	640	89	554	64	115	526	6.5	13
ERBD082R600W	640	89	554	64	115	526	6.5	13
ERBD068R800W	540	177	454	150	115	426	6.5	13
ERBD047R01K2	640	177	554	150	115	526	6.5	13
ERBD033R02K0	640	265	554	240	115	526	6.5	13
ERBD022R03K0	740	177	654	150	229	626	6.5	13
ERBD018R03K0	740	177	654	150	229	626	6.5	13

Connecting a brake resistor

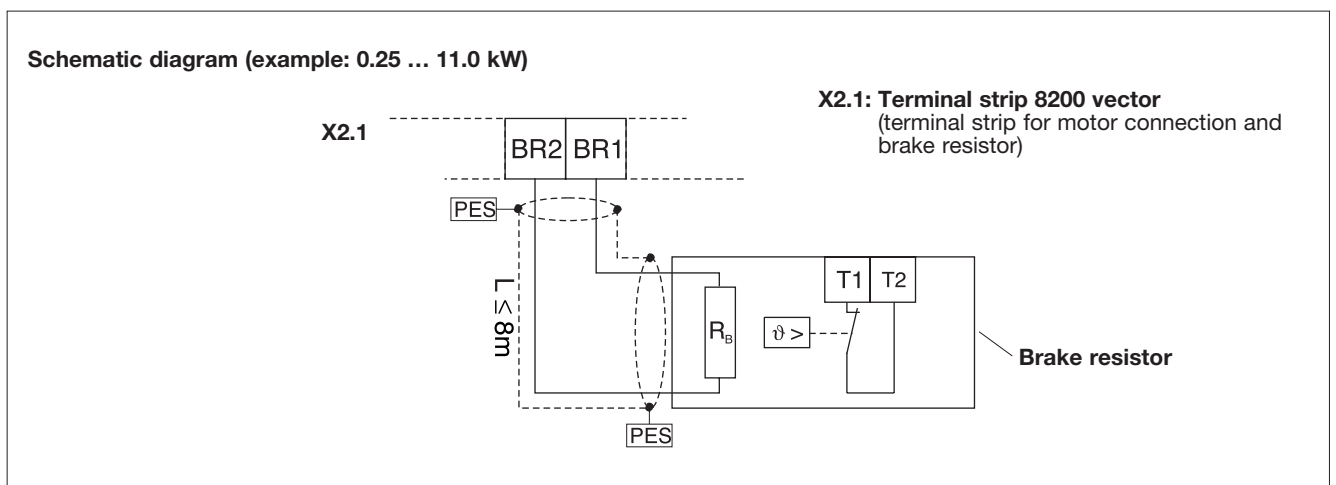

1, 2: Resistor

3, 4: Temperature monitoring (temperature switch/opener) to be integrated for example into the locking of the relevant mains supply protection

Brake rectifiers

Lenze three-phase motors and G-motion geared motors can be fitted with spring applied brakes.

A brake rectifier is required for the DC supply of the electromechanical motor brake (180 V DC, 205 V DC).

The brake rectifier has an integrated spark suppressor for protecting the switch contacts.

The selection of the brake rectifier is made depending on the input voltage U_{AC} and the rated brake coil voltage (U_{coil}):

Braking rectifier	Type ref./order ref.	Max. input voltage U_{AC}	Rated voltage U_{DC} (V)	Max. output voltage	Selection example
Bridge one-way rectifier	E82ZWBR1	270 V +0%	$U_{DC} = 0.9 \times U_{AC}$	0.75 A	$U_{coil} = 205 \text{ V}_{DC} = U_{DC}$ at $U_{AC} = 230 \text{ V}$
6-pin half wave rectifier	E82ZWBR3	460 V +0%	$U_{DC} = 0.45 \times U_{AC}$	0.75 A	$U_{coil} = 180 \text{ V}_{DC} = U_{DC}$ at $U_{AC} = 400 \text{ V}$

Note:

Lenze gearboxes and three-phase brake motors are supplied as standard with a **4-pin** brake rectifier. These brake rectifiers are designed for **AC-controlled** switching of the brake.

E82ZWBR3 = half wave rectifier
Type 14.630.33.016

E82ZWBR1 = bridge rectifier
Type 14.630.32.016





Activation of the brake

The brake is either DC or AC-controlled. The delay times are significantly reduced if the brake is DC-controlled. This makes it possible, for example, to brake the motor with a reproducible stopping distance. DC-controlled switching requires a spark suppressor to protect the switch contacts and the coil. The spark suppressor is integrated into the 6-pin brake rectifiers.

We recommend that the relay output¹⁾ of the 8200 vector frequency inverter is used to switch the brake. Alternatively, the brake can also be controlled via an external control contact (e.g. PLC). The following table lists the available options for Lenze brakes. The information relates to a mains rating of 230/400 V +/-10 %.

Brake coil voltage rating	Type of rectifier	Brake size (braking torque [Nm])		
		06 (4.0)	08 (8.0)	10 (16.0)
		Corresponding motor frame size		
		063/071	080/090	090/100
180 V	Half wave	<ul style="list-style-type: none"> AC-controlled switching via the relay output of the 8200 vector only permitted with additional auxiliary relay DC-controlled switching or direct switching of a DC voltage via the relay output of the 8200 vector only permitted with additional auxiliary relay 		
205 V ⁴⁾	Bridge	<ul style="list-style-type: none"> AC-controlled switching permitted via the relay output of the 8200 vector DC-controlled switching or direct switching of a DC voltage permitted via the relay output of the 8200 vector 		
24 V ²⁾	Not required	<ul style="list-style-type: none"> Direct switching of a DC voltage permitted via the relay output of the 8200 vector rectifier 		

Brake coil voltage rating	Type of rectifier	Brake size (braking torque [Nm])					
		12 (32.0) ³⁾	14 (60)	16 (80)	18 (150)	20 (240)	25 (360)
		Corresponding motor frame size					
		100	112/132	132/160	160/180	180/200	200/225
180 V	Half wave	<ul style="list-style-type: none"> AC-controlled switching via the relay output of the 8200 vector only permitted with additional auxiliary relay DC-controlled switching or direct switching of a DC voltage via the relay output of the 8200 vector only permitted with additional auxiliary relay 					
205 V	Bridge	<ul style="list-style-type: none"> AC-controlled switching via the relay output of the 8200 vector DC-controlled switching or direct switching of a DC voltage via the relay output of the 8200 vector only permitted with an additional auxiliary relay 					
24 V ²⁾	Not required	<ul style="list-style-type: none"> Direct switching of a DC voltage only permitted via the relay output of the 8200 vector with an additional auxiliary relay 					

¹⁾ Technical data for the relay output of the 8200 vector: see page 2-6.

The service life of the relay depends on the type of load and the connected power.

²⁾ DC-controlled switching requires a spark suppressor to protect the switching contact and the coil.

³⁾ At a brake coil voltage rating of 205 V and 24 V, a DC voltage may be switched directly via the relay output of the 8200 vector on inverters with ratings of 15 kW and higher.

⁴⁾ On 8200 vector types E82EV251K2Cxxx and E82EV371K2Cxxx, DC-controlled switching or direct switching of a DC voltage via the relay output is only permitted with an additional relay.

Activation of the brake

The relay must be programmed before the relay output of the 8200 vector frequency inverter can activate the electromechanical motor brake.

Example: Release/application of the brake (205 V) when an adjustable frequency threshold is exceeded/undercut. In this case the braking process can be initiated via a digital signal which leads to a quick stop of the drive.

(Programming: Use relay C0008 = 7, frequency threshold (Qmin) C0017 = 3 Hz; relay terminals K12, K14 at terminal strip X1 of the 8200 vector)

Schematic diagram

DC-controlled switching of the brake

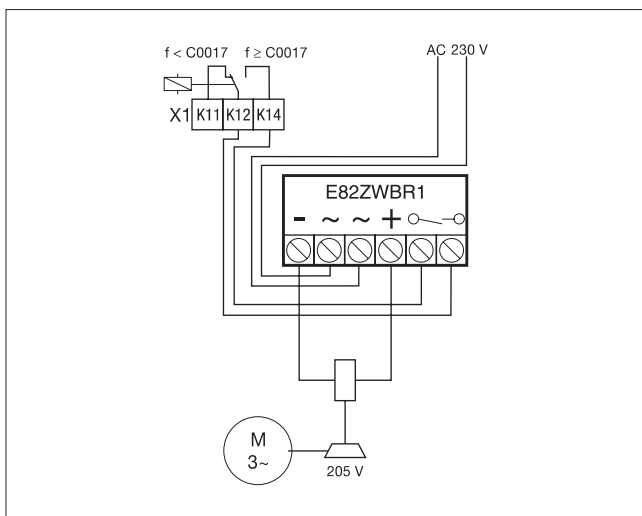

Schematic diagram

AC-controlled switching of the brake

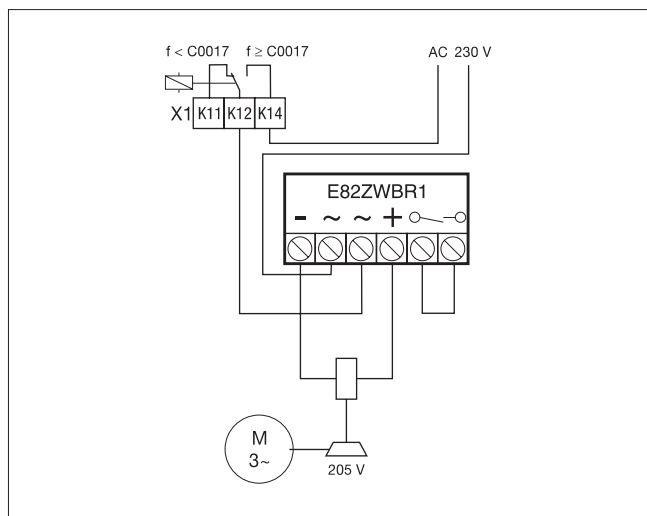

Sequence diagram

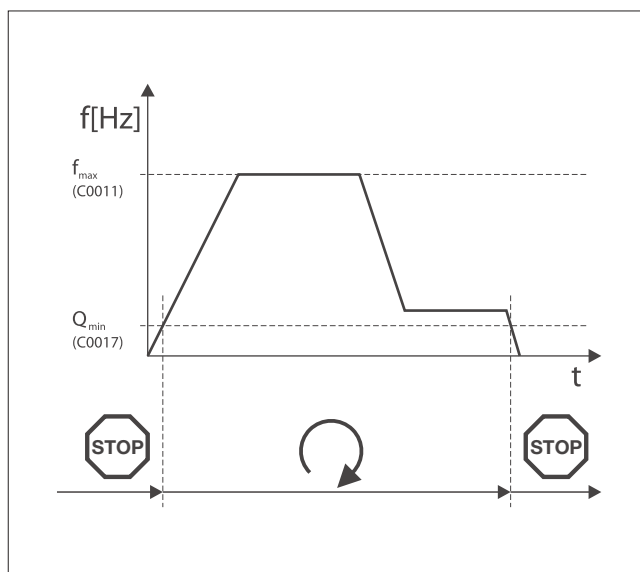

DC fuse

Two ranges of fuses are required to provide DC fuses for the entire power range of the drive controller. Fuse size 14*51 mm covers the rated current range from 6 to 40 A and fuse size 22*58 mm covers the range from 12 to 100 A. Only fuse holders of the same size may be interconnected via DC busbars. DC currents above 100 A can be implemented by connecting 22*58 mm DC fuses in parallel. The 8200 vector range is suitable for operation with 120% overload.

Note: A DC busbar system is available for each fuse range. At average supply levels, the current capacity $I = 200$ A. The busbar system for the 22*58 mm fuse range can be fitted with 14*51 mm range fuse holders. The 2-pin 14*51 mm must be extended for this purpose and the pins may need to be removed. This restricts the contact protection.

Type	Power [kW]	14*51 fuse without signalling device		14*51 fuse with signalling device	
		Fuse rating [A]	Order ref.	Fuse rating [A]	Order ref.
1~ 230 V					
E82xV551K2C	0.55	10	EFSGR0100AYHN	10	EFSGR0100AYHK
E82xV751K2C	0.75	12	EFSGR0120AYHN	12	EFSGR0120AYHK
E82xV152K2C	1.5	25	EFSGR0250AYHN	25	EFSGR0250AYHK
E82xV222K2C	2.2	32	EFSGR0320AYHN	32	EFSGR0320AYHK
3~ 230 V					
E82xV551K2C	0.55	8	EFSGR0080AYHN	8	EFSGR0080AYHK
E82xV751K2C	0.75	10	EFSGR0100AYHN	10	EFSGR0100AYHK
E82xV152K2C	1.5	16	EFSGR0160AYHN	16	EFSGR0160AYHK
E82xV222K2C	2.2	25	EFSGR0250AYHN	25	EFSGR0250AYHK
E82xV302K2C	3	32	EFSGR0320AYHN	32	EFSGR0320AYHK
E82xV402K2C	4	40	EFSGR0400AYHN	40	EFSGR0400AYHK
E82xV552K2C	5.5	40	EFSGR0400AYHN	40	EFSGR0400AYHK
E82xV752K2C	7.5				
3~ 400 V					
E82xV551K4C	0.55	6	EFSGR0060AYHN	6	EFSGR0060AYHK
E82xV751K4C	0.75	6	EFSGR0060AYHN	6	EFSGR0060AYHK
E82xV152K4C	1.5	10	EFSGR0100AYHN	10	EFSGR0100AYHK
E82xV222K4C	2.2	12	EFSGR0120AYHN	12	EFSGR0120AYHK
E82xV302K4C	3	20	EFSGR0200AYHN	20	EFSGR0200AYHK
E82xV402K4C	4	25	EFSGR0250AYHN	25	EFSGR0250AYHK
E82xV552K4C	5.5	32	EFSGR0320AYHN	32	EFSGR0320AYHK
E82xV752K4C	7.5	40	EFSGR0400AYHN	40	EFSGR0400AYHK
E82xV113K4C	11	40	EFSGR0400AYHN	40	EFSGR0400AYHK
Brake modules					
9351		20	EFSGR0200AYHN	20	EFSGR0200AYHK
9352					

Lenze offers a DC busbar system - EWZ 0036 - for DC fuses 14*51 mm with and without alarm contact.



		22*38 fuse without signalling device		22*38 fuse with signalling device	
Type	Power [kW]	Fuse rating [A]	Order ref.	Fuse rating [A]	Order ref.
1~ 230 V					
E82xV551K2C	0.55	12	EFSGR0120AYIN	12	EFSGR0120AYIK
E82xV751K2C	0.75	12	EFSGR0120AYIN	12	EFSGR0120AYIK
E82xV152K2C	1.5	25	EFSGR0250AYIN	25	EFSGR0250AYIK
E82xV222K2C	2.2	32	EFSGR0320AYIN	32	EFSGR0320AYIK
3~ 230 V					
E82xV551K2C	0.55	12	EFSGR0120AYIN	12	EFSGR0120AYIK
E82xV751K2C	0.75	12	EFSGR0120AYIN	12	EFSGR0120AYIK
E82xV152K2C	1.5	16	EFSGR0160AYIN	16	EFSGR0160AYIK
E82xV222K2C	2.2	25	EFSGR0250AYIN	25	EFSGR0250AYIK
E82xV302K2C	3	32	EFSGR0320AYIN	32	EFSGR0320AYIK
E82xV402K2C	4	40	EFSGR0400AYIN	40	EFSGR0400AYIK
E82xV552K2C	5.5	40	EFSGR0400AYIN	40	EFSGR0400AYIK
E82xV752K2C	7.5	63	EFSGR0630AYIN	63	EFSGR0630AYIK
3~ 400 V					
E82xV551K4C	0.55	12	EFSGR0120AYIN	12	EFSGR0120AYIK
E82xV751K4C	0.75	12	EFSGR0120AYIN	12	EFSGR0120AYIK
E82xV152K4C	1.5	12	EFSGR0120AYIN	12	EFSGR0120AYIK
E82xV222K4C	2.2	12	EFSGR0120AYIN	12	EFSGR0120AYIK
E82xV302K4C	3	20	EFSGR0200AYIN	20	EFSGR0200AYIK
E82xV402K4C	4	25	EFSGR0250AYIN	25	EFSGR0250AYIK
E82xV552K4C	5.5	32	EFSGR0320AYIN	32	EFSGR0320AYIK
E82xV752K4C	7.5	40	EFSGR0400AYIN	40	EFSGR0400AYIK
E82xV113K4C	11	40	EFSGR0400AYIN	40	EFSGR0400AYIK
Brake modules					
9351		20	EFSGR0200AYIN	20	EFSGR0200AYIK
9352		50	EFSGR0500AYIN	50	EFSGR0500AYIK

Lenze offers a DC busbar system - EWZ 0036 - for DC fuses 22*38 mm with and without alarm contact.

Fuse holder 14*51 mm	
Name	Order ref.
Fuse holder, 2-pin, without signalling device ¹⁾	EFH20005
Fuse holder, 1-pin, with signalling device ^{2,3)}	EFH10005

Fuse holder 22*58 mm	
Name	Order ref.
Fuse holder, 2-pin, without signalling device ¹⁾	EFH20007
Fuse holder, 1-pin, with signalling device ^{2,3)}	EFH10004

Miscellaneous accessories ²⁾	
Name	Order ref.
DC busbar for 14*51 mm, 1m	EWZ0036
DC busbar for 22*58 mm, 1m	EWZ0037
Fuse-link contacts for DC busbar (unit packs of 10)	EWZ0038
1-pin terminal for internal supply of busbars for 14*51 and 22*58 mm ⁴⁾	EWZ0039

¹⁾ UL approval only for AC operation.

²⁾ The 14*51 and 22*58 mm fuse-links with signalling device, fuse holders with signalling device and accessories do not have UL approval.

³⁾ Two fuse holders are needed for each.

⁴⁾ The terminal provides a simple way of connecting a central power supply to the busbar system and of connecting busbar systems. Two terminals are required in each instance.

Setpoint potentiometer

Speed can be preselected through an external potentiometer (setpoint preselection or field frequency preselection).

For this purpose, the setpoint potentiometer can be connected to terminals 7, 8 and 9 of the standard I/O module. A scale and a rotary knob are also available.

Name	Order ref.	Data	Dimensions
Setpoint potentiometer	ERPD0001k0001W	1 k Ω /1 Watt	6 mm x 35 mm
Rotary knob	ERZ0001		36 mm diameter
Scale	ERZ0002	0...100%	62 mm diameter



Digital display

A voltmeter can be connected to the analog outputs to display the output frequency or the motor speed.

Name	Order ref.	Measuring ranges	Mounting cut-out	Mounting depth
Voltmeter 3 1/2 digits	EPD203	0 - 6 V 0 - 20 V 0 - 200 V	91 mm x 22.5 mm	81.5 mm





EMC shield support

The EMC shield support is available to speed up and facilitate the mounting of shielded control cables. A shield sheet and clips are supplied with the frequency inverter. The angular design means that the control cable can take the shortest route possible from the inverter into

the cable channel without bending the cable excessively. More detailed information about EMC installation can be found in the System Manual (see page 6-3).

Type	Name	Order ref.
E82xV251KxCxxx to E82xV371KxCxxx	EMC shield support	E82ZWEM1
E82xV551KxCxxx to E82xV222KxCxxx	EMC shield support	E82ZWEM2
E82xV302KxCxxx to E82xV112KxCxxx	EMC shield support	E82ZWEM3



PTC kit

The PTC kit must be used if you are using unshielded PTC cables in the motor cabling. In addition to the EMC shield support, the frequency inverter is also supplied with a PTC module.

The PTC module replaces a ferrite core installed in the PTC cable. Pre-assembled terminal connectors enable the PTC module to be installed quickly and easily.

Type	Name	Order ref.
E82xV251KxCxxx to E82xV371KxCxxx	PTC kit	E82ZPE1
E82xV551KxCxxx to E82xV222KxCxxx	PTC kit	E82ZPE2
E82xV302KxCxxx to E82xV112KxCxxx	PTC kit	E82ZPE3



Plug connector for function modules

The plug connector connects the function module to the inverter. The plug connector is supplied with the 8200 vector inverter.

Plug connector	Order ref.	E82ZJ011





“General accessories” overview tables

Accessories	Name	Order ref.	
Function modules	Standard I/O PT	E82ZAFSC010	
	Application I/O PT	E82ZAFAC010	
	CAN PT (system bus)	E82ZAFCC010	
	CAN I/O PT (system bus)	E82ZAFCC210	
	LECOM-B PT (RS485)	E82ZAFLC010	
	INTERBUS PT	E82ZAFIC010	
	PROFIBUS-DP PT	E82ZAFPC010	
	AS-Interface PT	E82ZAFFC010	
Communication modules	LECOM-LI (optical fibres)	EMF2102IB-V003	
	LECOM-AB (RS232/485)	EMF2102IB-V001	
	LON	EMF2141IB	
	CAN	EMF2171IB	
	CAN (with addressing)	EMF2172IB	
	INTERBUS	EMF2111IB	
	INTERBUS Loop	EMF2112IB	
	PROFIBUS-DP	EMF2133IB	
	DeviceNet/CANopen	EMF2175IB	
	Keypad	E82ZBC	
	Keypad XT	EMZ9371BC	
	Miscellaneous	Hand terminal = Handheld keypad (additional connecting cable required)	E82ZBB
Hand terminal = Handheld Keypad XT (additional connecting cable required)		E82ZBBXC	
Control cabinet installation kit ¹⁾ (additional connecting cable required)		E82ZBHT	
Connecting cable		2.5 m	E82ZWL025
		5 m	E82ZWL050
		10 m	E82ZWL100
“Global Drive Control” (GDC) parameter setting software		ESP-GDC2	
“Global Drive Control (GDCeasy)” parameter setting software		ESP-GDC2-E	
PC system cable RS232		0.5 m	EWL0048
		5 m	EWL0020
		10 m	EWL0021
Optical fibre adapter for normal output power		EMF2125IB	
Optical fibre adapter for high output power		EMF2126IB	
Mains supply for optical fibre adapter		EJ0013	
Optical fibre, 1-wire, black PE sleeve (simple protection), sold by the metre		EWZ0007	
Optical fibre, 1-wire, red PUR sleeve (reinforced protection), sold by the metre		EWZ0006	
Setpoint potentiometer		ERP0001K0001W	
Rotary knob for setpoint potentiometer		ERZ0001	
Scale for setpoint potentiometer		ERZ0002	
Digital display		EPD203	
EMC shield support 0.25 ... 0.37 kW		E82ZWEM1	
EMC shield support 0.55 ... 2.2 kW		E82ZWEM2	
EMC shield support 3.0 ... 11.0 kW		E82ZWEM3	
PTC kit 0.25 ... 0.37 kW		E82ZPE1	
PTC kit 0.55 ... 2.2 kW		E82ZPE2	
PTC kit 3.0 ... 11.0 kW		E82ZPE3	
Plug connector		E82ZJ011	

¹⁾ Required for example if the keypad is to be mounted in the control cabinet door (only in connection with keypad E82ZBC)

Accessories

Miscellaneous

Accessories	Name	Order ref.
Braking	Half wave rectifier (14.630.33.016)	E82ZWBR3
	Bridge rectifier (14.630.32.016)	E82ZWBR1
Automation	Drive PLC	EPL-10200
	Extension Board 1	EPZ-10201
	Extension Board 2	EPZ-10202
	Extension Board 3	EPZ-10203
	Drive PLC Developer Studio BASIC	ESP-DDS1-B
	Drive PLC Developer Studio PROFESSIONAL	ESP-DDS1-P
	PC system bus converter (voltage supply via keyboard with DIN connection)	EMF2173IB
	PC system bus converter (voltage supply via keyboard with PS2 connection)	EMF2173IB-V002
	Terminal extension for system bus (CAN)	EMZ9374IB
System manual 8200 vector ¹⁾	German	EDS82EV903
	English	
	French	
Communication manual CAN ¹⁾	German	EDSCAN
	English	
	French	
Communication manual INTERBUS ¹⁾	German	EDSIBUS
	English	
	French	
Communication manual PROFIBUS ¹⁾	German	EDSPBUS
	English	
	French	
Communication manual LECOM ¹⁾	German	EDSLECOM
	English	
	French	

¹⁾ Please specify the required language when ordering documentation.



“Type-specific accessories” overview tables

Operation at rated power (normal operation) 1~230 V

8200 vector						
Voltage [V]	1~230					
Type	E82EV251K2C	E82EV371K2C	E82EV551K2C	E82EV751K2C	E82EV152K2C	E82EV222K2C
Accessories						
Name	Order ref.					
Circuit-breaker	EFA1C10A	EFA1C10A	EFA1B10A	EFA1B16A EFA1B10A ²⁾	EFA1B20A EFA1B16A ²⁾	EFA1B20A
Fuse	EFSM-0100AWE	EFSM-0100AWE	EFSM-0100AWE	EFSM-0160AWE EFSM-0100AWE ²⁾	EFSM-0200AWE EFSM-0160AWE ²⁾	EFSM-0200AWE
Fuse holder	EFH10001					
Mains choke	ELN1-0900H005		ELN1-0500H009		ELN1-0250H018 ³⁾	
LL RFI filter ¹⁾	E82ZZ37112B220		E82ZZ75112B220		-	
SD RFI filter ¹⁾	E82ZZ37112B200		E82ZZ75112B200		E82ZZ22212B200	
LD RFI filter ¹⁾	E82ZZ37112B210		E82ZZ75112B210		E82ZZ22212B210	
Motor filter	E82ZM22232B					
Brake resistor	ERBM470R020W		ERBM200R100W		ERBM082R150W	ERBM052R200W
Swivel bracket	E82ZJ001					
DIN rail mounting	E82ZJ002					
EMC shield support	E82ZWEM1		E82ZWEM2			
PTC kit	E82ZPE1		E82ZPE2			
DC fuse without signalling device	-		EFSGR0100AYHN	EFSGR0120AYHN	EFSGR0250AYHN	EFSGR0320AYHN
DC fuse with signalling device	-		EFSGR0100AYHK	EFSGR0120AYHK	EFSGR0250AYHK	EFSGR0320AYHK
Plug connector	E82ZJ011					

3~230 V

8200 vector				
Voltage [V]	3~230			
Type	E82EV551K2C	E82EV751K2C	E82EV152K2C	E82EV222K2C
Accessories				
Name	Order ref.			
Circuit-breaker	EFA3B06A	EFA3B10A EFA3B06A ²⁾	EFA3B16A EFA3B10A ²⁾	EFA3B16A EFA3B10A ²⁾
Fuse	EFSM-0060AWE	EFSM-0100AWE EFSM-0060AWE ²⁾	EFSM-0160AWE EFSM-0100AWE ²⁾	EFSM-0160AWE EFSM-0100AWE ²⁾
Fuse holder	EFH10001			
Mains choke	E82ZL75132B		E82ZL22232B	
SD RFI filter ¹⁾	E82ZZ75132B200		E82ZZ22232B200	
LD RFI filter ¹⁾	E82ZZ75132B210		E82ZZ22232B210	
Motor filter	E82ZM22232B			
Brake resistor	ERBM200R100W		ERBM082R150W	ERBM052R200W
Swivel bracket	E82ZJ001			
Hutschienenbefestigung	E82ZJ002			
EMC shield support	E82ZWEM2			
PTC kit	E82ZPE2			
DC fuse without signalling device	EFSGR0080AYHN	EFSGR0100AYHN	EFSGR0160AYHN	EFSGR0250AYHN
DC fuse with signalling device	EFSGR0080AYHK	EFSGR0100AYHK	EFSGR0160AYHK	EFSGR0250AYHK
Plug connector	E82ZJ011			

¹⁾ Only in conjunction with the 8200 vector, types E82EVxxxKx200

²⁾ For operation with a mains choke

³⁾ Always use a mains choke

Accessories

Miscellaneous

Operation at rated power (normal operation), 3~230 V

8200 vector				
Voltage [V]	3~230			
Type	E82EV302K2C	E82EV402K2C	E82EV552K2C	E82EV752K2C
Accessories				
Name	Order ref.			
Circuit-breaker	EFA3B20A EFA3B16A ²⁾	EFA3B25A EFA3B20A ²⁾	EFA3B25A ²⁾	-
Fuse	EFSM-0200AWE EFSM-0160AWE ²⁾	EFSM-0250AXH EFSM-0200AWE ²⁾	EFSM-0320AWH EFSM-0250AXH ²⁾	EFSM-0320AWH
Fuse holder	EFH10001	EFH10002 EFH10001 ²⁾	EFH10002	
Mains choke	ELN3-0120H017		ELN3-0120H025	ELN3-0088H035 ³⁾
SD RFI filter ¹⁾	E82ZZ40232B200		E82ZZ75232B200	
LD RFI filter ¹⁾	E82ZZ40232B210		E82ZZ75232B210	
Motor filter	E82ZM75234B		E82ZM11334B	
Brake resistor	ERBD047R01K2			
Swivel bracket	E82ZJ005		E82ZJ006	
EMC shield support	E82ZWEM3			
PTC kit	E82ZPE3			
DC fuse without signalling device	EFSGR0320AYHN	EFSGR0400AYHN		-
DC fuse with signalling device	EFSGR0320AYHK	EFSGR0400AYHK		-
Plug connector	E82ZJ011			

¹⁾ Only in conjunction with the 8200 vector, types E82EVxxxKxC200

²⁾ For operation with a mains choke

³⁾ Always use a mains choke



Operation at rated power (normal operation), 3~400 V

8200 vector				
Voltage [V]	3~400			
Type	E82EV551K4C ⁴⁾	E82EV751K4C ⁴⁾	E82EV152K4C ⁴⁾	E82EV222K4C ⁴⁾
Accessories				
Name	Order ref.			
Circuit-breaker	EFA3B06A	EFA3B06A	EFA3B10A	EFA3B10A
Fuse	EFSM-0060AWE	EFSM-0060AWE	EFSM-0100AWE	EFSM-0100AWE
Fuse holder	EFH10001			
Mains choke	EZN3A1500H003		E82ZL22234B	
SD RFI filter ¹⁾	E82ZZ75134B200		E82ZZ22234B200	
LD RFI filter ¹⁾	E82ZZ75134B210		E82ZZ22234B210	
Motor filter	E82ZM75134B		E82ZM22234B020	
Brake resistor	ERBM470R100W		ERBM370R150W	ERBM240R200W
Swivel bracket	E82ZJ001			
DIN rail mounting	E82ZJ002			
EMC shield support	E82ZWEM2			
PTC kit	E82ZPE2			
DC fuse without signalling device	EFSGR0060AYHN		EFSGR0100AYHN	EFSGR0120AYHN
DC fuse with signalling device	EFSGR0060AYHK		EFSGR0100AYHK	EFSGR0120AYHK
Plug connector	E82ZJ011			

¹⁾ Only in conjunction with the 8200 vector, types E82EVxxxKxC200

²⁾ For operation with a mains choke

³⁾ Always use a mains choke

⁴⁾ In case of the 8200 vector with integrated EMC filter the following applies:
In the mains voltage range from 484 V (-0 %) ... 550 V (+0 %), operation is only permitted with brake resistor

3~400 V

8200 vector					
Voltage [V]	3~400				
Type	E82EV302K4C	E82EV402K4C	E82EV552K4C	E82EV752K4C	E82EV113K4C
Accessories					
Name	Order ref.				
Circuit-breaker	EFA3B16A EFA3B10A ²⁾	EFA3B16A	EFA3B25A EFA3B20A ²⁾	EFA3B32A EFA3B20A ²⁾	EFA3B32A
Fuse	EFSM-0160AWE EFSM-0100AWE ²⁾	EFSM-0160AWE	EFSM-0250AXH EFSM-0200AWE ²⁾	EFSM-0320AWH EFSM-0200AWE ²⁾	EFSM-0320AWH
Fuse holder	EFH10001		EFH10002 EFH10001 ²⁾	EFH10002 EFH10001 ²⁾	EFH10002
Mains choke	EZN3A0500H007	EZN3A0300H013		ELN3-0120H017	ELN3-0150H024 ³⁾
SD RFI filter ¹⁾	E82ZZ55234B200			E82ZZ11334B200	
LD RFI filter ¹⁾	E82ZZ55234B210			E82ZZ11334B210	
Motor filter	E82ZM40234B		E82ZM75234B		E82ZM11334B
Brake resistor	ERBD180R300W	ERBD100R600W	ERBD082R600W	ERBD068R800W	ERBD047R01K2
Swivel bracket	E82ZJ005			E82ZJ006	
EMC shield support	E82ZWEM3				
PTC kit	E82ZPE3				
DC fuse without signalling device	EFSGR0200AYHN	EFSGR0250AYHN	EFSGR0320AYHN	EFSGR0400AYHN	
DC fuse with signalling device	EFSGR0200AYHK	EFSGR0250AYHK	EFSGR0320AYHK	EFSGR0400AYHK	
Plug connector	E82ZJ011				

¹⁾ Only in conjunction with the 8200 vector, types E82EVxxxKxC200

²⁾ For operation with a mains choke

³⁾ Always use a mains choke

Operation at rated power (normal operation), 3~400 V

8200 vector				
Voltage [V]	3~400			
Type	E82EV153K4B201	E82EV223K4B201 ²⁾	E82EV303K4B201 ²⁾	E82EV453K4B201 ²⁾
Accessories				
Name	Order ref.			
Built-on mains filter A ¹⁾	EZN3A0110H030	EZN3A0080H042	EZN3A0055H060	EZN3A0037H090
Built-on mains filter B ¹⁾	EZN3B0110H030	EZN3B0080H042	EZN3B0055H060	EZN3B0037H090
Footprint RFI filters	E82ZZ15334B230	-	-	-
Footprint mains filter	E82ZN22334B230	E82ZN22334B230	E82ZN30334B230	E82ZN45334B230
Mains choke	ELN3-088H035	ELN3-0075H045	ELN3-0055H055	ELN3-0038H085
Motor filter	ELM3-004H055	ELM3-004H055	on request	on request
Sinusoidal filter	on request	on request	on request	on request
Brake module	EMB9351-E	EMB9351-E	EMB9351-E	EMB9351-E
Brake chopper	EMB9352-E	EMB9352-E	EMB9352-E	EMB9352-E
Brake resistor	ERBD033R02K0	ERBD022R03K0	ERBD018R03K0	ERBD022R03K0

¹⁾ Only in conjunction with the 8200 vector, types E82EVxxxKxB201

²⁾ Always use a mains choke or mains filter

3~400 V

8200 vector			
Voltage [V]	3~400		
Type	E82EV553K4B201 ²⁾	E82EV753K4B201 ²⁾	E82EV903K4B201 ²⁾
Accessories			
Name	Order ref.		
Built-on mains filter A ¹⁾	EZN3A0030H110	EZN3A0022H150	EZN3A0017H200
Built-on mains filter B ¹⁾	EZN3B0033H110	EZN3B0022H150	EZN3B0017H200
Footprint mains filter	E82ZN55334B230	E82ZN75334B230	E82ZN90334B230
Mains choke ¹⁾	ELN3-0027H105	ELN3-0022H130	ELN3-0017H170
Motor filter	on request	on request	on request
Sinusoidal filter	on request	on request	on request
Brake module	EMB9351-E	EMB9351-E	EMB9351-E
Brake chopper	EMB9352-E	EMB9352-E	EMB9352-E
Brake resistor	ERBD018R03K0	ERBD022R03K0	ERBD018R03K0

¹⁾ Only in conjunction with the 8200 vector, types E82EVxxxKxB201

²⁾ Always use a mains choke or mains filter



Operation at increased rated power, 1~230 V

8200 vector				
Voltage [V]	1~230			
Type	E82EV251K2C	E82EV551K2C	E82EV751K2C	E82EV152K2C
Accessories				
Name	Order ref.			
Circuit-breaker	EFA1C10A	EFA1B10A	EFA1B16A	EFA1B20A
Fuse	EFSM-0100AWE	EFSM-0100AWE	EFSM-0160AWE	EFSM-0200AWE
Fuse holder	EFH10001			
Mains choke	ELN1-0900H005	ELN1-0500H009	ELN1-0500H009 ³⁾	ELN1-0250H018
SD RFI filter ¹⁾	E82ZZ37112B200	E82ZZ75112B200		E82ZZ22212B200
LD RFI filter ¹⁾	E82ZZ37112B210	E82ZZ75112B210		E82ZZ22212B210
Motor filter	E82ZM22232B			
Brake resistor	ERBM470R020W	ERBM200R100W		ERBM082R150W
Swivel bracket	E82ZJ001			
DIN rail mounting	E82ZJ002			
EMC shield support	E82ZWEM1	E82ZWEM2		
PTC kit	E82ZPE1	E82ZPE2		
DC fuse without signalling device	-	EFSGR0100AYHN	EFSGR0120AYHN	EFSGR0250AYHN
DC fuse with signalling device	-	EFSGR0100AYHK	EFSGR0120AYHK	EFSGR0250AYHK
Plug connector	E82ZJ011			

¹⁾ Only in conjunction with the 8200 vector, types E82EVxxxKxC200 ³⁾ Always use a mains choke when operating the system with increased power rating

²⁾ For operation with a mains choke

3~230 V

8200 vector				
Voltage [V]	3~230			
Type	E82EV551K2C	E82EV751K2C	E82EV152K2C	
Accessories				
Name	Order ref.			
Circuit-breaker	EFA3B06A	EFA3B10A	EFA3B16A EFA3B10A ²⁾	
Fuse	EFSM-0060AWE	EFSM-0100AWE	EFSM-0160AWE EFSM-0100AWE ²⁾	
Fuse holder	EFH10001			
Mains choke	E82ZL75132B	E82ZL75132B ³⁾	E82ZL22232B	
SD RFI filter ¹⁾	E82ZZ75132B200			E82ZZ22232B200
LD RFI filter ¹⁾	E82ZZ75132B210			E82ZZ22232B210
Motor filter	E82ZM22232B			
Brake resistor	ERBM200R100W			ERBM082R150W
Swivel bracket	E82ZJ001			
DIN rail mounting	E82ZJ002			
EMC shield support	E82ZWEM2			
PTC kit	E82ZPE2			
DC fuse without signalling device	EFSGR0080AYHN	EFSGR0100AYHN	EFSGR0160AYHN	
DC fuse with signalling device	EFSGR0080AYHK	EFSGR0100AYHK	EFSGR0160AYHK	
Plug connector	E82ZJ011			

¹⁾ Only in conjunction with the 8200 vector, types E82EVxxxKxC200 ³⁾ Always use a mains choke when operating the system with increased power rating

²⁾ For operation with a mains choke

Operation at increased rated power, 3~230 V

8200 vector		
Voltage [V]	3~230	
Type	E82EV302K2C	E82EV552K2C
Accessories		
Name	Order ref.	
Circuit-breaker	EFA3B25A EFA3B20A ²⁾	EFA3B32A
Fuse	EFSM-0250AXH EFSM-0200AWE ²⁾	EFSM-0320AWH
Fuse holder	EFH10002 EFH10001 ²⁾	EFH10002
Mains choke	ELN3-0120H017	ELN3-0088H035 ³⁾
SD RFI filter ¹⁾	E82ZZ40232B200	E82ZZ75232B200
LD RFI filter ¹⁾	E82ZZ40232B210	E82ZZ75232B210
Motor filter	E82ZM75234B	E82ZM11334B
Brake resistor	ERBD047R01K2	
Swivel bracket	E82ZJ005	E82ZJ006
EMC shield support	E82ZWEM3	
PTC kit	E82ZPE3	
DC fuse without signalling device	EFSGR0320AYHN	EFSGR0400AYHN
DC fuse with signalling device	EFSGR0320AYHK	EFSGR0400AYHK
Plug connector	E82ZJ011	

¹⁾ Only in conjunction with the 8200 vector, types E82EVxxxKxC200

²⁾ For operation with a mains choke

³⁾ Always use a mains choke



Operation at increased rated power, 3~400 V

8200 vector			
Voltage [V]	3~400		
Type	E82EV551K4C	E82EV751K4C	E82EV222K4C
Accessories			
Name	Order ref.		
Circuit-breaker	EFA3B06A	EFA3B06A	EFA3B10A
Fuse	EFSM-0060AWE	EFSM-0060AWE	EFSM-0100AWE
Fuse holder	EFH10001		
Mains choke	EZN3A1500H003	EZN3A1500H003 ³⁾	EZ82ZL22234B ³⁾
SD RFI filter ¹⁾	E82ZZ75134B200		E82ZZ22234B200
LD RFI filter ¹⁾	E82ZZ75134B210		E82ZZ22234B210
Motor filter	E82ZM75134B		E82ZM22234B020
Brake resistor	ERBM470R100W		ERBM240R200W
Swivel bracket	E82ZJ001		
DIN rail mounting	E82ZJ002		
EMC shield support	E82ZWEM2		
PTC kit	E82ZPE2		
DC fuse without signalling device	EFSGR060AYHN		EFSGR0120AYHN
DC fuse with signalling device	EFSGR060AYHK		EFSGR0120AYHK
Plug connector	E82ZJ011		

¹⁾ Only in conjunction with the 8200 vector, types E82EVxxxKxC200

²⁾ For operation with a mains choke

³⁾ Always use a mains choke when operating the system with increased power rating

3~400 V

8200 vector			
Voltage [V]	3~400		
Type	E82EV302K4C	E82EV402K4C	
Accessories			
Name	Order ref.		
Circuit-breaker	EFA3B16A EFA3B10A ²⁾	EFA3B16A	
Fuse	EFSM-0160AWE EFSM-0100AWE ²⁾	EFSM-0160AWE	
Fuse holder	EFH10001		
Mains choke	EZN3A0300H013	EZN3A0300H013 ³⁾	
SD RFI filter ¹⁾	E82ZZ55234B200		
LD RFI filter ¹⁾	E82ZZ55234B210		
Motor filter	E82ZM40234B		
Brake resistor	ERBD180R300W	ERBD100R600W	
Swivel bracket	E82ZJ005		
EMC shield support	E82ZWEM3		
PTC kit	E82ZPE3		
DC fuse without signalling device	EFSGR0200AYHN	EFSGR0250AYHN	
DC fuse with signalling device	EFSGR0200AYHK	EFSGR0250AYHK	
Plug connector	E82ZJ011		

¹⁾ Only in conjunction with the 8200 vector, types E82EVxxxKxC200

²⁾ For operation with a mains choke

³⁾ Always use a mains choke when operating the system with increased power rating

Operation at increased rated power, 3~400 V

8200 vector				
Voltage [V]	3~400			
Type	E82EV153K4B201 ²⁾	E82EV223K4B201 ²⁾	E82EV303K4B201 ²⁾	E82EV453K4B 201 ²⁾
Accessories				
Name	Order ref.			
Built-on mains filter A ¹⁾	EZN3A0080H042	EZN3A0060H054	EZN3A0055H060	EZN3A0030H110
Built-on mains filter B ¹⁾	EZN3B0080H042	EZN3B0060H054	EZN3B0055H060	EZN3B0030H110
Footprint mains filter	E82ZN22334B230	E82ZN30334B230	–	–
Mains choke ¹⁾	ELN3-0075H045	ELN3-0055H055	ELN3-0055H055	ELN3-0027H105
Motor filter	ELM3-004H055	on request	on request	on request
Sinusoidal filter	on request	on request	on request	on request
Brake module	EMB9351-E	EMB9351-E	EMB9351-E	EMB9351-E
Brake chopper	EMB9352-E	EMB9352-E	EMB9352-E	EMB9352-E
Brake resistor	ERBD033R02K0	ERBD022R03K0	ERBD018R03K0	ERBD022R03K0

¹⁾ Only in conjunction with the 8200 vector, types E82EVxxxKxB201

²⁾ Always use a mains choke or mains filter

8200 vector			
Voltage [V]	3~400		
Type	E82EV553K4B201 ²⁾	E82EV753K4B201 ²⁾	E82EV903K4B201 ²⁾
Accessories			
Name	Order ref.		
Built-on mains filter A ¹⁾	–	EZN3A0022H150	EZN3A0017H200
Built-on mains filter B ¹⁾	–	EZN3B0022H150	EZN3B0017H200
Footprint mains filter	–	E82ZN90334B230	–
Mains choke ¹⁾	ELN3-0022H130	ELN3-0017H170	ELN3-0014H200
Motor filter	on request	on request	on request
Sinusoidal filter	on request	on request	on request
Brake module	EMB9351-E	EMB9351-E	EMB9351-E
Brake chopper	EMB9352-E	EMB9352-E (3 x)	EMB9352-E (3 x)
Brake resistor	ERBD018R03K0 (2 x)	ERBD022R03K0	ERBD018R03K0

¹⁾ Only in conjunction with the 8200 vector, types E82EVxxxKxB201

²⁾ Always use a mains choke or mains filter



Application examples | 8200 vector

Setting applications (speed adjustment) _____ 5-2

Preselection of setpoints via a potentiometer ____ 5-2

Preselection of fixed setpoints _____ 5-3

Setpoint preselection via the UP/DOWN function __ 5-4

Preselection of setpoints via the keypad _____ 5-5

Control applications (speed control) _____ 5-6

Rotational speed control _____ 5-6

Pressure control _____ 5-7

Dancer positioning control _____ 5-9

Group of drives _____ 5-10

Sequential switching _____ 5-11

Setpoint summation _____ 5-12

Power regulation _____ 5-13

Application examples

Setting applications (speed adjustment)

Preselection of setpoints via potentiometer

The setpoint for the 8200 vector frequency inverter is selected using a (rotary) potentiometer. The frequency inverter is started and stopped via a digital signal.

Required accessories for the 8200 vector:

- Standard I/O or Standard I/O PT function module
- Setpoint potentiometer (1 k...10 k)
- Keypad

Tip: The setpoint potentiometer, rotary knob and scale are available as accessories (see page 4-44)

Terminal assignment on the Standard I/O function module:

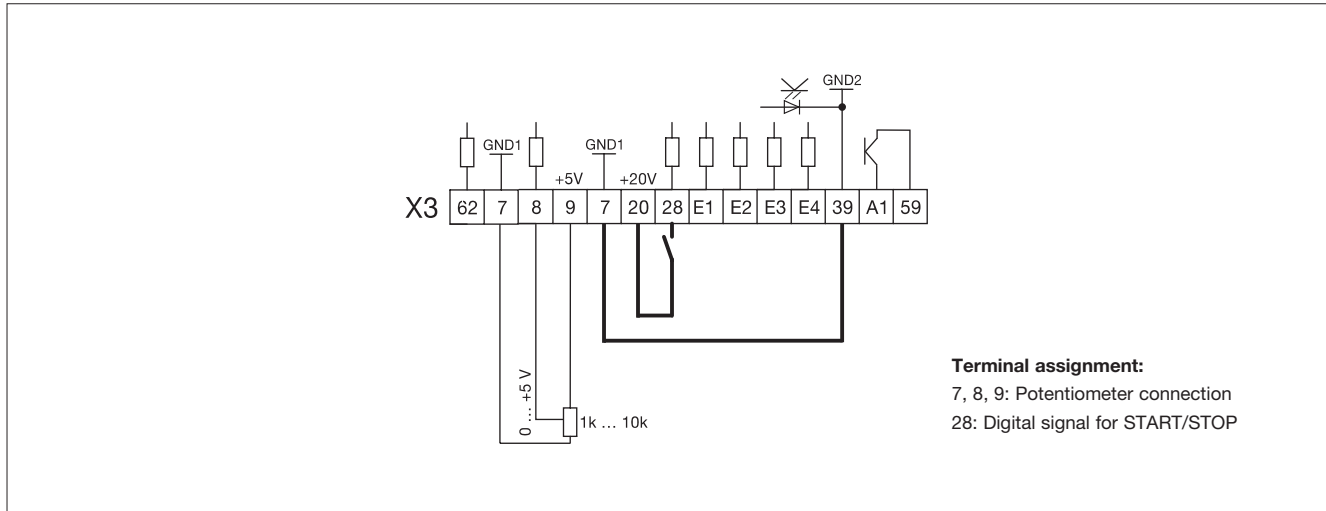

Sequence diagram:

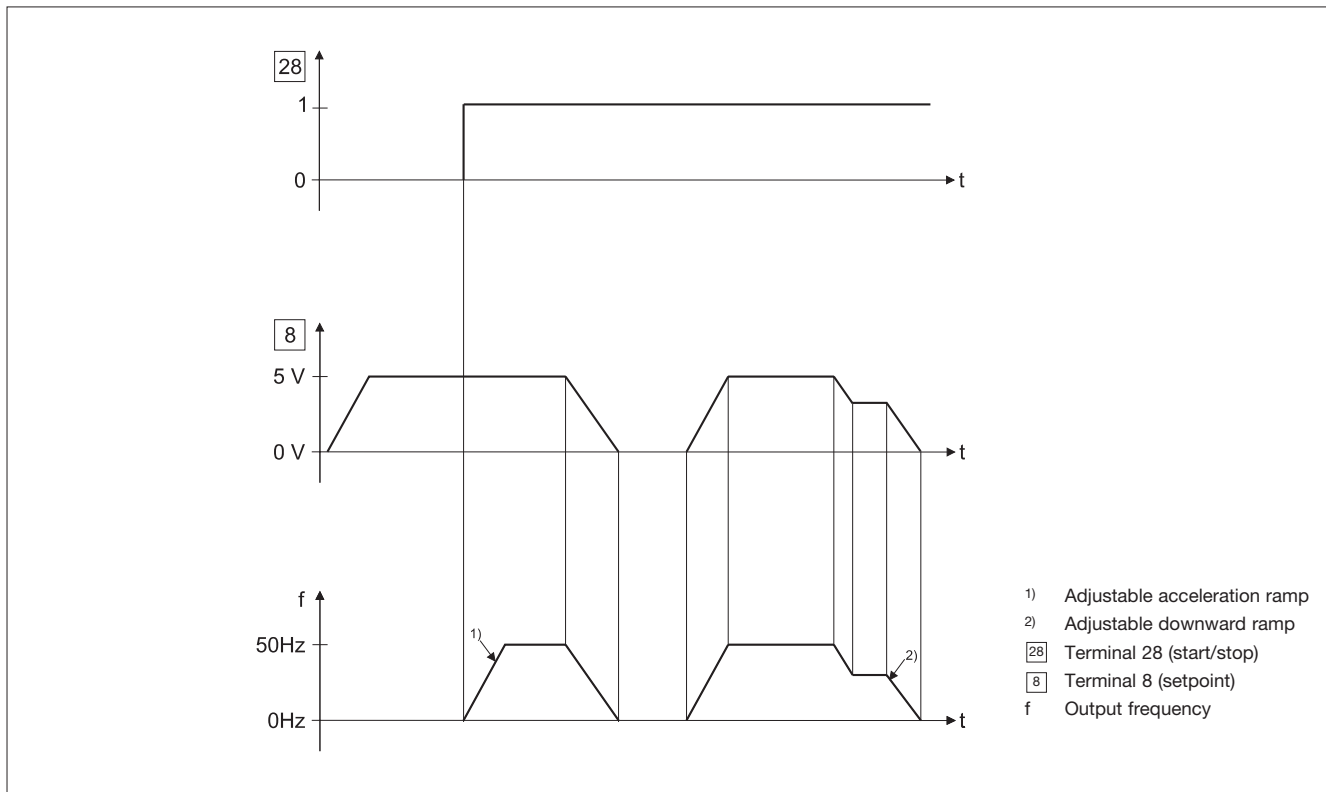

Preselection of fixed setpoints

The setpoint for the 8200 vector frequency inverter is selected via three fixed setpoints (JOG). Here, the three setpoints are entered once in the 8200 vector using the keypad. These setpoints are then activated via two digital signals. The frequency inverter is started and stopped via a further digital signal.

Required accessories for the 8200 vector:

- Standard I/O or Standard I/O PT function module
- Keypad

Terminal assignment on the Standard I/O function module:

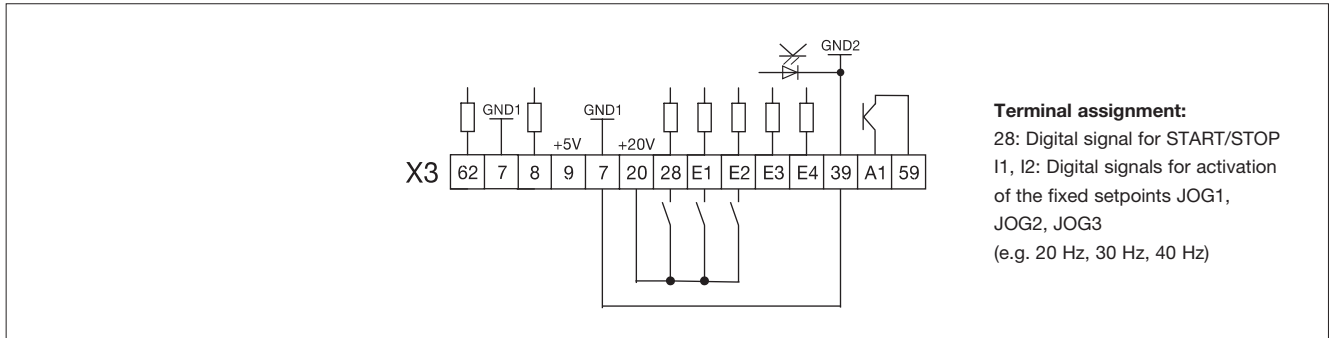

Sequence diagram:

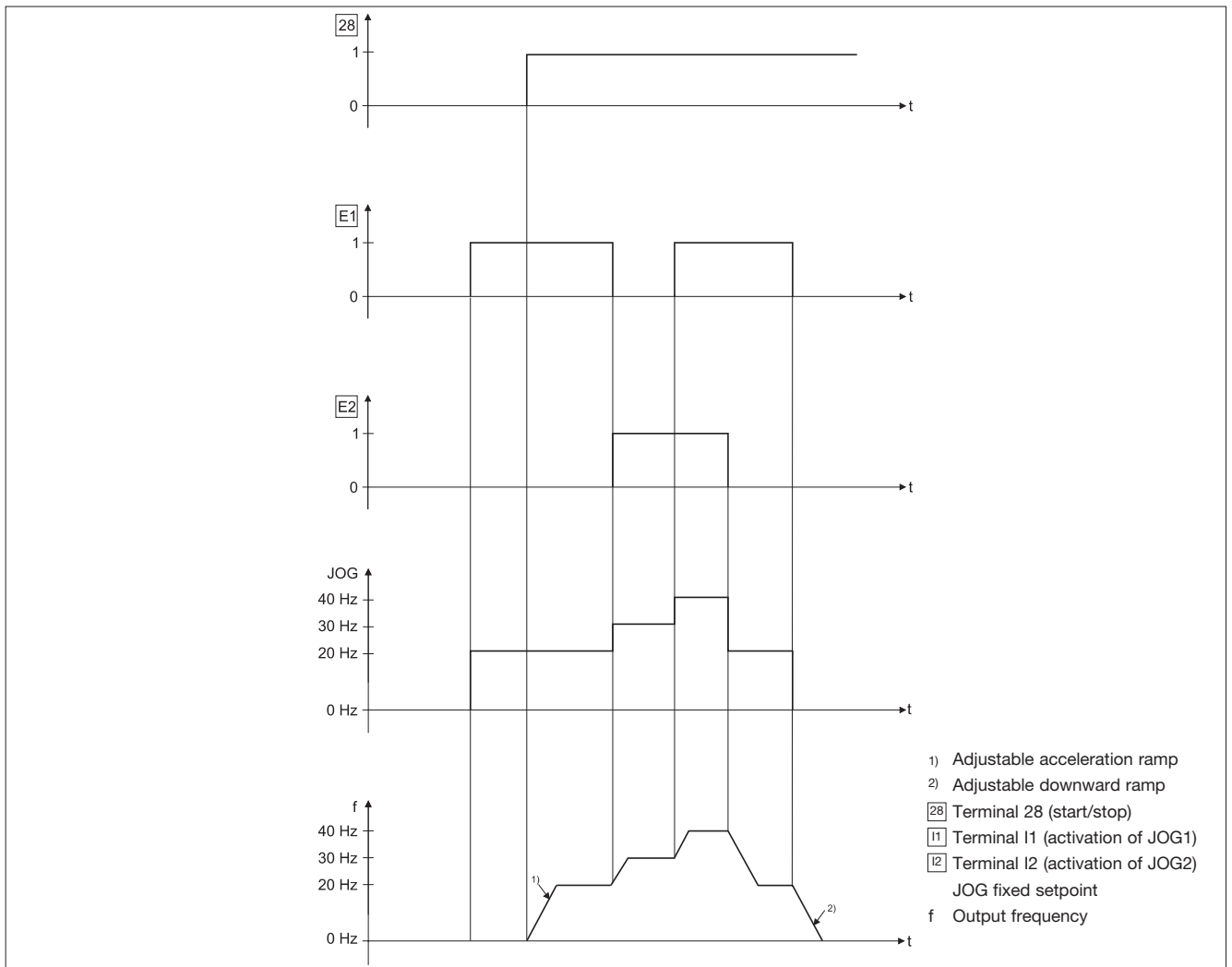

Application examples

Setting applications (speed adjustment)

Setpoint preselection via the UP/DOWN function

The setpoint for the 8200 vector frequency inverter is selected via two digital signals (UP and DOWN) (fail-safe). The signals can be generated for example with a simple pushbutton. The frequency inverter is started and stopped via a further digital signal.

Required accessories for the 8200 vector:

- Standard I/O or Standard I/O PT function module
- Keypad

Terminal assignment on the Standard I/O function module:

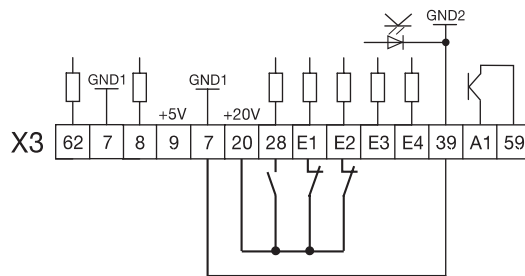

Terminal assignment:

28: Digital signal for START/STOP I1, I2:
Digital signals for setpoint preselection (UP/DOWN) via pushbutton

Sequence diagram:

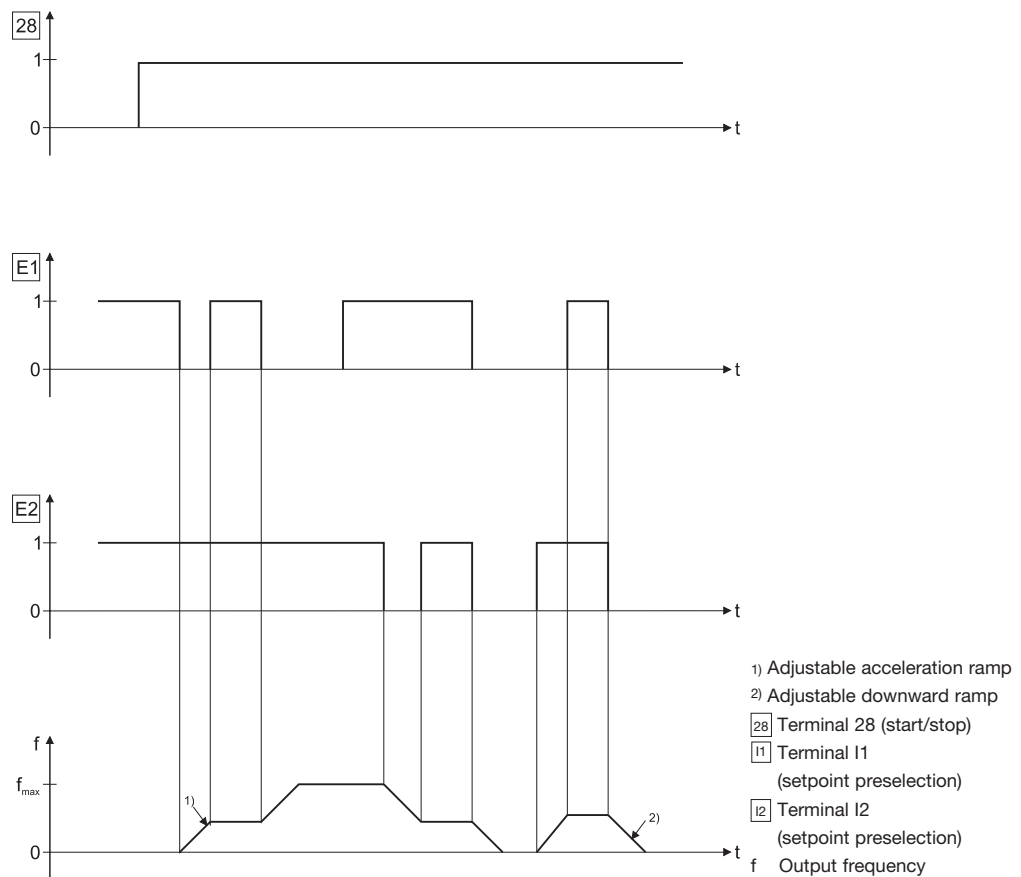

Preselection of setpoints via the keypad

The setpoint for the 8200 vector frequency inverter is selected via the **▲** and **▼** keys on the keypad. A reversal of the direction of rotation is possible here. The frequency inverter is started and stopped via the **RUN** and **STOP** keys.

Required accessories for the 8200 vector:

- Keypad

Selection of the setpoint:

The setpoint is selected using **Set**



← **Set**

▲ 0...+50 Hz ⇒ 

▼ 0...- 50 Hz ⇒ 

function Note:
The setpoint is saved when the mains is connected

Sequence diagram:

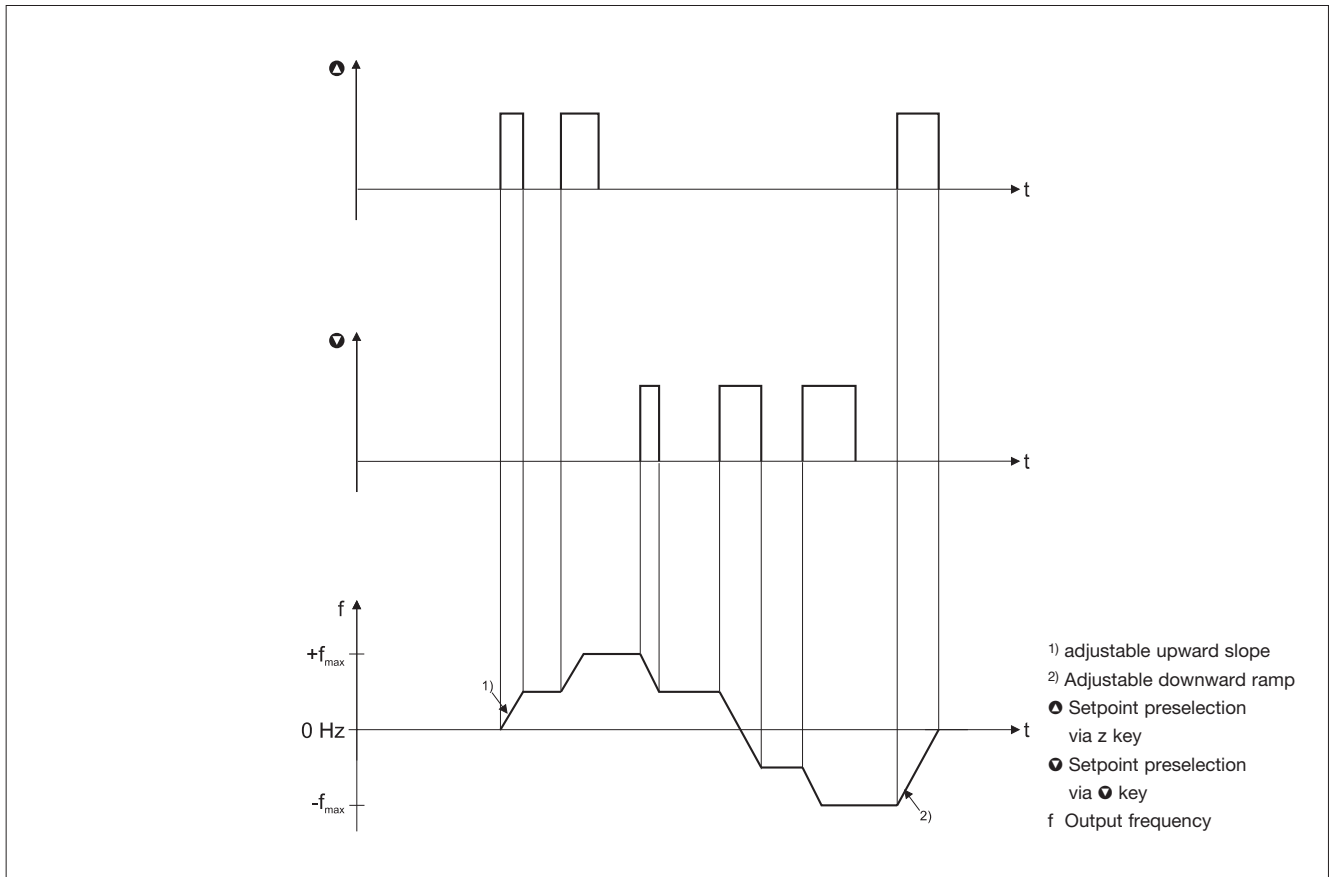

Rotational speed control

Rotational speed control with an inductive single-track 3-wire sensor.

The aim of the rotational speed controller is to count the error of the actual rotational speed from the setpoint speed, which arises as a result of the effects of loads (motive and generative) on the system. The inductive sensor measures the rotational speed by sensing for example a gear wheel, a metallic fan wheel or a cam. This inductive sensing can take place either directly on the motor or inside the machine.

Utilised functions

- Internal process controller for rotational speed control
- Input of rotational speed setpoint, e.g. via a keypad.
- Actual rotational speed value as a sequence of pulses via a digital input (configured as a frequency input).
- DC braking if the setpoint drops below an adjustable threshold.

Rotational speed control with a 3-wire sensor.

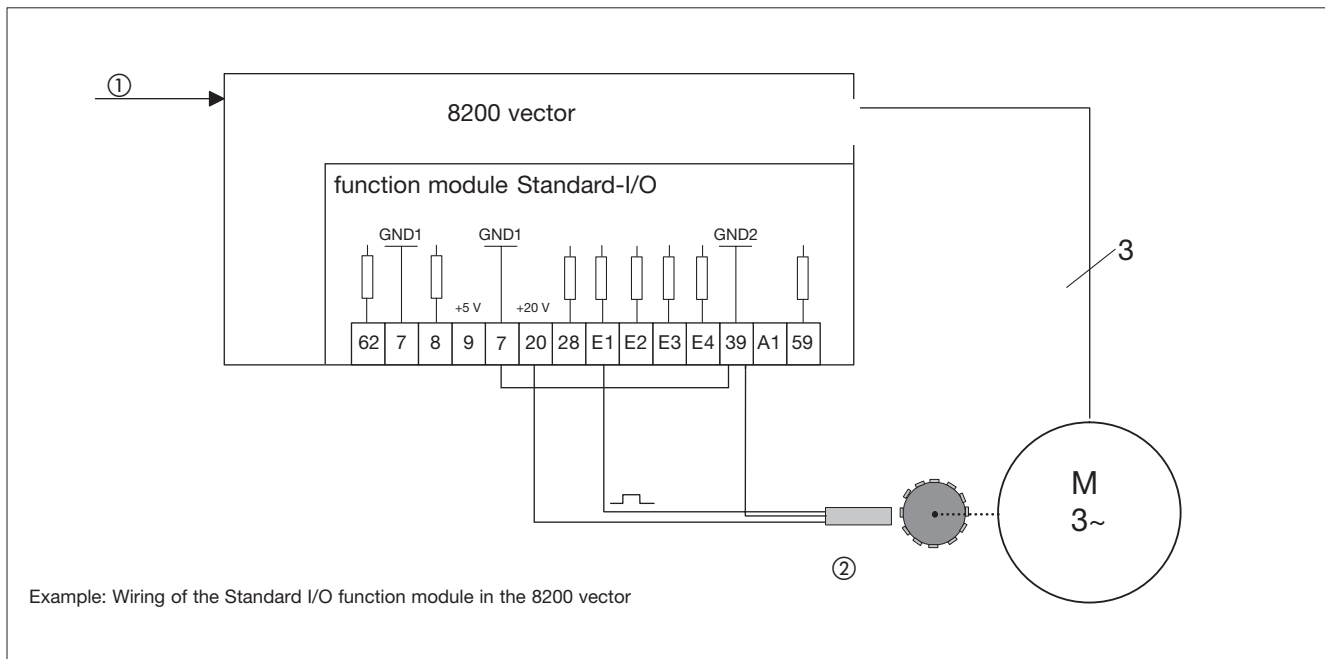

- ① Setpoint input via keypad
- ② 3-wire sensor

Further details about this application example can be found in the System Manual for the 8200 vector.

Tip:

Lenze three-phase AC motors and Lenze geared motors can be supplied with the Lenze pulse encoder ITD21 (512/2048 increments, HTL output signals). This enables **two-track** rotational speed feedback (tracks A and B) to be set up for the Application I/O function module.

Pressure control

A centrifugal pump (square load characteristic) is to maintain constant pressure in a pipe system (e.g. water supply for private households or industrial plants).

Application conditions

- PLC operation (preselection of the pressure setpoint, night-time pressure reduction)
- On-site set-up is possible
- During the night the pressure is reduced, and the pump then operates at an unregulated, low constant speed.
- Under no operating circumstances must the pump be operated at an output frequency of less than 10 Hz (running dry)
- Avoidance of pressure surges in the water network
- Avoidance of mechanical resonance at an output frequency of approx. 30 Hz
- Overheating protection for the motor
- Collective fault messaging to the PLC
- On-site display of readiness for operation and the actual pressure value
- On-site facility for stopping the pump

- Required drive components:
 - Lenze geared motor /three-phase AC motor
 - 8200 vector frequency inverter with Application I/O function module

Utilised functions

- Internal process controller for the pressure control
 - pressure setpoint from the PLC (4 ... 20 mA)
 - actual pressure reading from the sensor (0 ... 10 V)
- Hand/remote switchover for on-site set-up
 - hand: pressure setpoint entered via a pushbutton with motor potentiometer function (UP/DOWN)
 - remote: pressure setpoint from the PLC
- Fixed speed (JOG) for pressure reduction during the night (activated via the PLC)
- Protection against running dry (setpoint-independent minimum speed)
- Smooth and jerk-free starting action with S-ramps
- Masking of mechanical resonances with a cancelling frequency
- PTC motor monitoring
- Trip error message via a digital output
- Readiness for operation signalled via a relay output
- Configurable analog outputs for actual pressure value
- Electronic security lock

Application examples

Control applications (speed control)

Basic circuit for a pressure control system

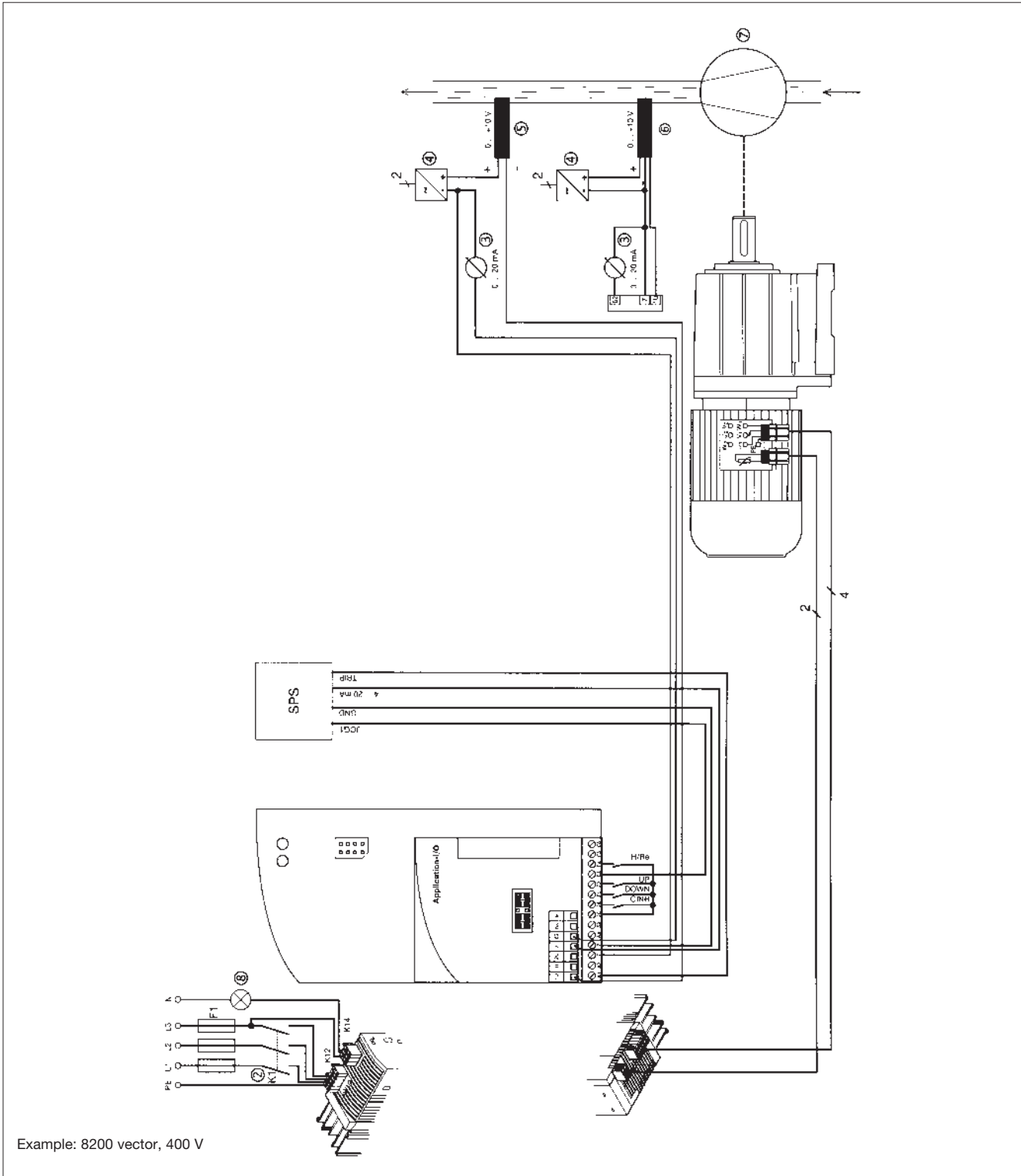

Example: 8200 vector, 400 V

- ② Mains contactor
- ③ Analog display instrument for actual pressure values
- ④ External mains supply
- ⑤ 2-wire pressure sensor
- ⑥ 3-wire pressure sensor
- ⑦ Pump
- ⑧ Lamp on = ready for operation
- ⑤, ⑥: only use one pressure sensor

Further details about this application example can be found in the System Manual for the 8200 vector.

Dancer positioning control

Dancer position control is used in ongoing processes to give constant material tension. In the example described, the continuous material speed v_2 is synchronised with the line speed v_1 .

Required drive components

- Lenze geared motor/three-phase AC motor
- 8200 vector frequency inverter with Application I/O function module

Utilised functions

- Internal process controller as a position controller.
- Preselection of the line speed v_1 via analog inputs at the function module (terminal 1U).
- Actual dancer position value from the dancer potentiometer via an analog input at the function module (terminal 2U).
- Set-up speed via digital input at the function module (fixed speed/JOG via E3).
- Shut-off of the dancer controller via X3/E4 (external), also possible internally via an adjustable frequency threshold.

Basic circuit for a dancer position control system

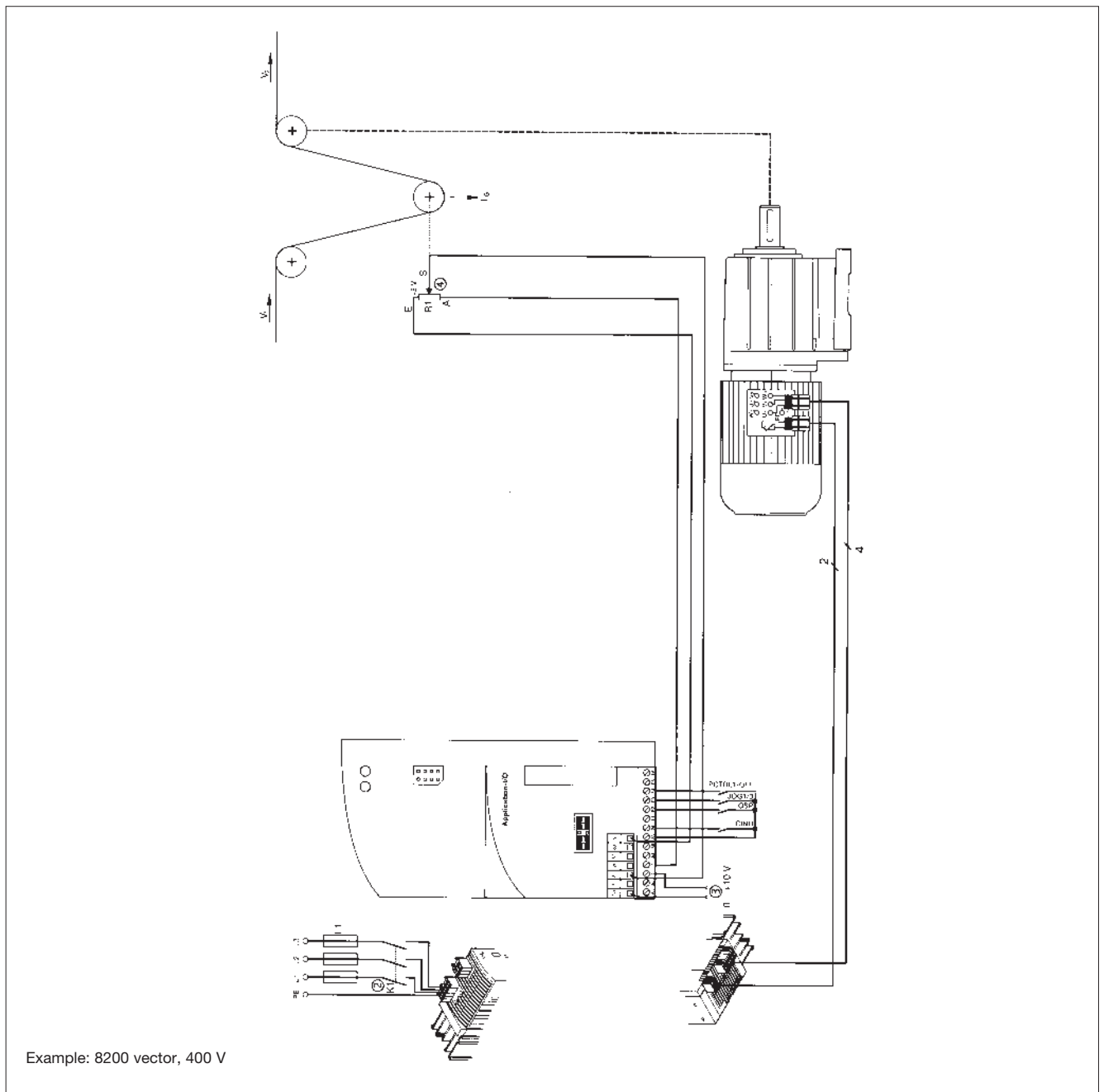

- ② Mains contactor
- ③ Master setpoint $\sim V_1$
- ④ Dancer potentiometer

Further details about this application example can be found in the System Manual for the 8200 vector.

Application examples

Group of drives

In the operating mode “V/f characteristic control” it is possible to connect several motors in parallel to the 8200 vector.

The total sum of the individual motor power ratings must not exceed the current rating of the 8200 vector.

Installation information

- The wiring is connected in parallel, e.g. in a terminal box.
- Every motor must be equipped with a temperature switch (NC contact), which is connected in series to X2/T1 and X2/T2.
- Resulting motor cable length:

$$l_{\text{res}} = \text{Sum of all motor cable lengths} \times \sqrt{\text{number of motor cables}}$$

Basic design of a drive group

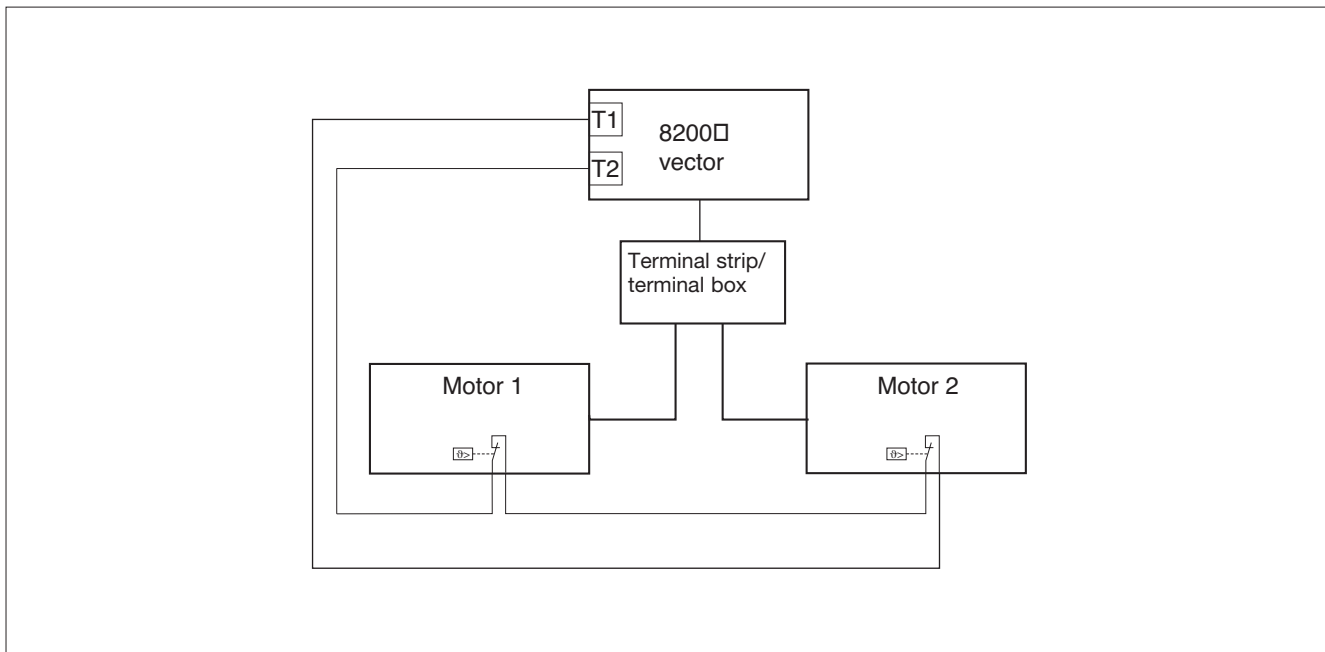

5

Further details about this application example can be found in the System Manual for the 8200 vector.

Two refrigeration compressors supply several cooling consumers, which are switched on and off at irregular intervals.

Conditions

- Compressor 1 is regulated with an 8200 vector.
- Compressor 2 has a fixed connection to the network and is switched on or off by the 8200 vector depending on the cooling requirements.
- The selection of the pressure setpoint of the refrigeration process is fixed in the 8200 vector.

Utilised functions

- Controller release/inhibit function for starting and stopping
- Internal process controller for pressure control
- Fixed frequency
- Programmable relay output K1
- Adjustable switching thresholds
- Parameter set transfer

The principle of sequential switching

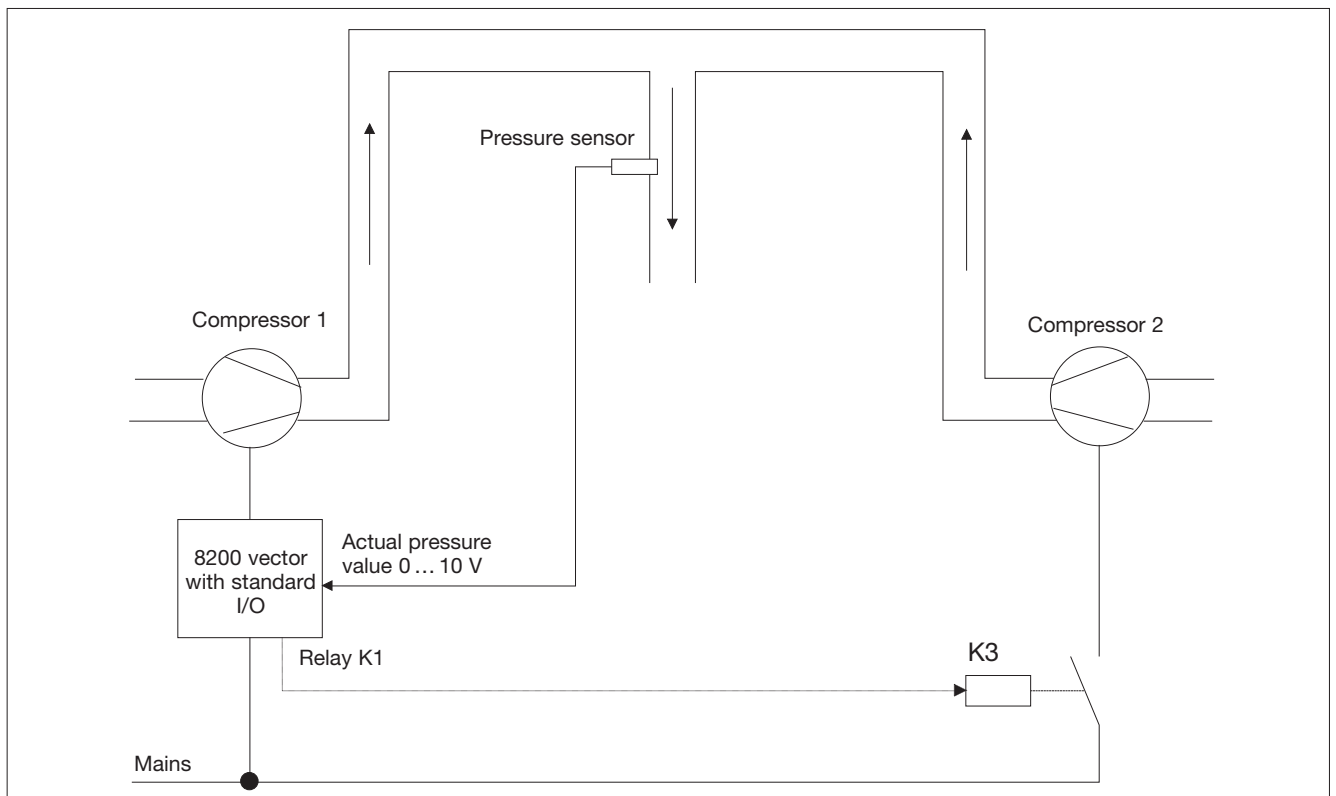

Tip:

When using the Application I/O function module, time delays at relay output K1 may render the otherwise necessary external time delay element unnecessary – the time delay element prevents compressor 2 from switching on during temporary fluctuations in actual value.

Further details about this application example can be found in the System Manual for the 8200 vector.

Application examples

Setpoint summation

Conveyor systems, pumps etc. are often operated at a basic speed which can be increased as required. Here, the speed is implemented by the 8200 vector by preselection of a master setpoint and an additional setpoint. These setpoints may originate from different sources (e.g. PLC and setpoint potentiometer).

The 8200 vector adds the two analog setpoints and then increases the speed of the motor accordingly. The upward and downward ramps for both setpoints are variable and can be adjusted to ensure smooth acceleration. In addition, the master setpoint ramps can be set to an S-shape.

Block diagram for setpoint summation

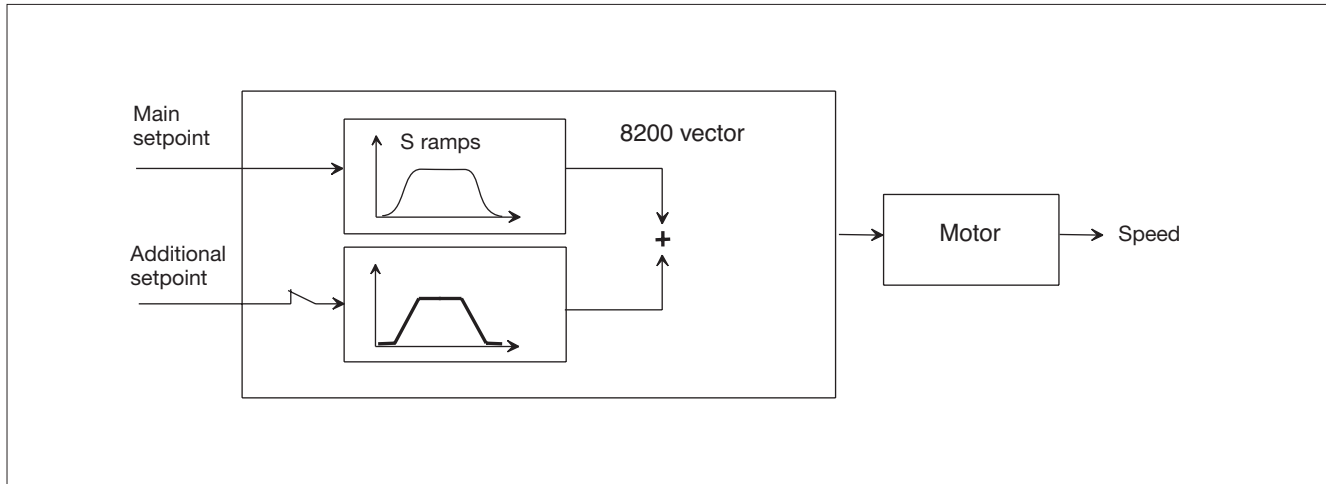

Further details about this application example can be found in the System Manual for the 8200 vector.

Power control (torque limitation) is used for example to ensure a constant flow of mass when media which change their specific gravity are moved – usually air at different temperatures. Here, a torque limit (M) and a rotational speed setpoint (f) are preselected for the 8200 vector.

Automatic adaptation of the rotational speed ensures that the torque limit is adhered to when the specific gravity changes, provided that the value of the rotational speed setpoint is selected high enough to not have a limiting effect.

The principle of power control demonstrated with a fan

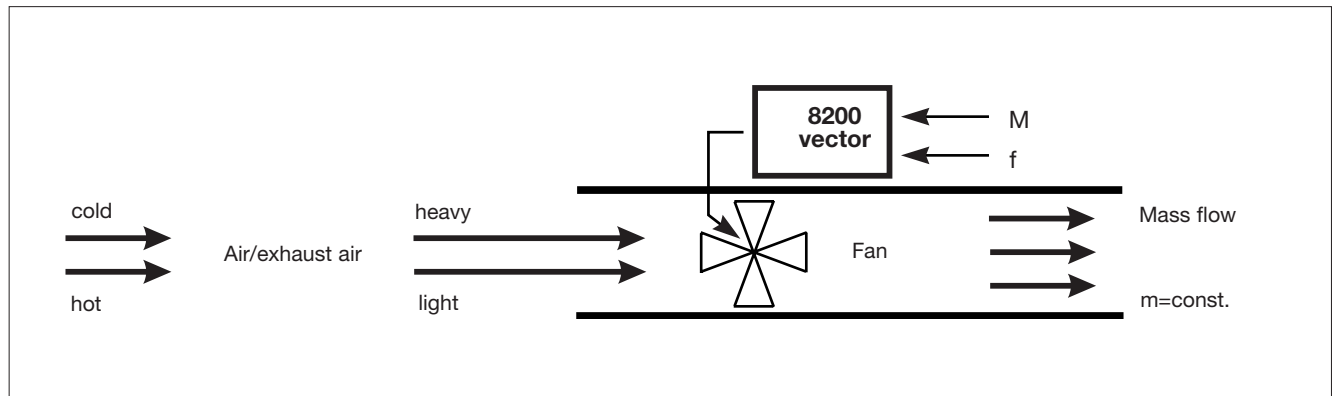

Further details about this application example can be found in the System Manual for the 8200 vector.

Lenze

Services | 8200 vector

Service _____ 6-2

Related documentation _____ 6-3

Technical documentation _____ 6-3

Other product catalogs _____ 6-4

Fax order form _____ 6-7

Service – you can trust

For us, service is more than just supporting the use of our drives. The Lenze system approach begins with your enquiry. Next you get technical information and advice from the Internet and a network of sales outlets staffed by knowledgeable engineers. If you need it, we follow with training, commissioning, maintenance and repair.

With passion

The Lenze team doesn't just offer the necessary manpower and technical know-how – we are passionate and meticulous about what we do. We'll only be happy once you are entirely satisfied with our work. Our team of professionals provides assistance over the telephone or on-site, ensures the express delivery of spare parts and carries out repairs with incredible urgency. We're fast and reliable.

Someone to talk to

Should you come across a real problem, we can provide live assistance. Your local sales office is staffed with product trained engineers who can give expert advice. Technical support and service is available, even outside normal office hours. Check our website for contact numbers.

Around the world

Our products are available for speedy delivery worldwide. Lenze companies, Lenze factories and sales agencies are based in major industrial countries around the world. Contact them through our website, which also gives you 24 hour access to technical instructions and product manuals. Local support, on-site if you need it, is available.



Technical documentation

The documentation for the 8200 vector contains supplementary information about the inverter and the various function and communication modules. The manuals are divided into clear sections, enabling you to find the information you need quickly and easily. All manuals are bound in ring binders.

		Order ref.
System manual 8200 vector ¹⁾	German	EDS82EV903
	English	
	French	
Communication manual CAN ¹⁾	German	EDSCAN
	English	
	French	
Communication manual INTERBUS ¹⁾	German	EDSIBUS
	English	
	French	
Communication manual PROFIBUS ¹⁾	German	EDSPBUS
	English	
	French	
Communication manual LECOM ¹⁾	German	EDSLECOM
	English	
	French	

¹⁾ Please specify the required language when ordering documentation.

Other product catalogs

Lenze manufactures state-of-the-art electronic drives and geared motors from DC and frequency inverters to servo technology, small drives, clutches and brakes, which are in use all over the world. Why not find out more?

Automation

Hardware and software components for distributed automation

Motor inverters

The IP 65 inverter directly on the drive, 0.25 - 7.5 kW

Frequency inverters

Standard or vector control up to 400 kW

Geared motors

Industrial geared motor ranges suiting market requirements up to 45 kW

Three-phase AC motors

Standard motors in B3, B14 or B5 up to 22.0 kW

Servo drives

4 different technology functions, 0.75 to 75 kW

Servo motors

Synchronous motors up to 6.0 kW, asynchronous motors up to 60 kW

DC drives

DC speed controllers and DC motors up to 500 kW

Small drives

The modular range of motors and geared motors for customer-specific variants up to 1100 kW

Brakes and clutches

An important addition to your application

Connection systems

From drive to toothed belt

