



**ROBO Cylinder  
RCP6/RCP6S Actuator  
Rod Type  
Instruction Manual**

═══════════════ **Second edition** ════════════════

Motor Straight Type: RA4C, RA6C, RA7C, RA8C  
Side-Mounted Motor Type: RA4R, RA6R, RA7R, RA8R

***IAI America, Inc.***



## **Please Read Before Use**

Thank you for purchasing our product.

This instruction manual explains the handling methods, structure and maintenance of this product, among others, providing the information you need to know to use the product safely.

Before using the product, be sure to read this manual and fully understand the contents explained herein to ensure safe use of the product.

The DVD that comes with the product contains instruction manuals for IAI products. When using the product, refer to the necessary portions of the applicable instruction manual by printing them out or displaying them on a PC.

After reading the instruction manual, keep it in a convenient place so that whoever is handling this product can reference it quickly when necessary.

### **[Important]**

- This instruction manual is original.
- This product is not to be used for any other purpose from what is noted in this instruction manual. IAI shall not be liable whatsoever for any loss or damage arising from the result of using the product for any other purpose from what is noted in the manual.
- The information contained in this instruction manual is subject to change without notice for the purpose of production improvement.
- If you have any question or finding regarding the information contained in this instruction manual, contact our customer center or our sales office near you.
- Using or copying all or a part of this instruction manual without permission is prohibited.
- The company names, names of products and trademarks of each company shown in the sentences are registered trademarks.

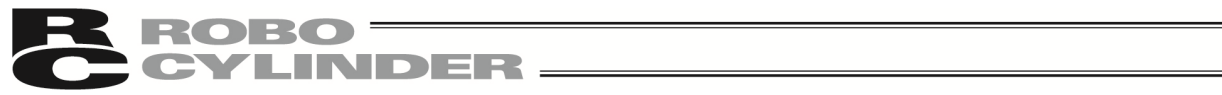

Description of RCP6S controller unit is not included in this instruction manual.

With regard to RCP6S controller unit, refer to the separate instruction manual.

## Table of Contents

Safety Guide .....	1
Caution in Handling .....	8
International Standards Compliances .....	9
Names of the Parts .....	10
1. Specifications Check .....	16
1.1 Checking the Product .....	16
1.1.1 Parts .....	16
1.1.2 Related Instruction Manuals for the Each Controller Supported by This Product .....	17
1.1.3 How to Read the Model Nameplate .....	17
1.2 Specifications .....	19
1.2.1 Speed .....	19
1.2.2 Maximum Acceleration and Transportable Mass .....	23
1.2.3 Driving System • Position Detector .....	46
1.2.4 Positioning Precision .....	46
1.2.5 Rod Tip Load .....	46
1.2.6 Current Limit Value and Pressing Force .....	47
1.2.7 Rod Tip Inclination Amount (reference) .....	51
1.2.8 Duty Ratio for Continuous Operation .....	53
1.3 Options .....	54
1.3.1 Brake Type (Model: B) .....	54
1.3.2 Reversed-home Specification (Model: NM) .....	54
1.3.3 Flange Bracket (Front) (Model: FL) .....	54
1.3.4 Foot Bracket (Model: FT) .....	55
1.3.5 T-slot Nut Bar (Model: NTB) .....	55
1.3.6 Tip Adapter (Internal Thread) (Model: NFA) .....	56
1.3.7 Motor Left Side-Mounted, Motor Top Side-Mounted, Motor Right Side-Mounted (Model: ML, MT, MR) .....	58
1.3.8 Cable Exit Direction Changed (Model: CJT, CJR, CJL, CJB, CJO) .....	58
1.4 Motor • Encoder Cables .....	59
1.4.1 Dedicated connection cable for other than RCON and RCM-P6PC .....	59
1.4.2 Dedicated connection cable for RCON and RCM-P6PC .....	63
2. Installation .....	66
2.1 Transportation .....	66

2.2	Installation and Storage • Preservation Environment.....	68
2.3	How to Install .....	69
2.3.1	Installation.....	69
2.3.2	Installation of the Main Unit .....	70
3.	Connecting with the Controller .....	88
4.	Caution for Operation.....	93
5.	Maintenance and Inspection .....	94
5.1	Inspection Items and Schedule.....	94
5.2	External Visual Inspection.....	95
5.3	Cleaning.....	95
5.4	Grease Supply.....	95
5.4.1	What Grease to Use .....	95
5.4.2	How to Apply Grease.....	96
5.5	Procedure for Belt Replacement and Tuning .....	97
5.5.1	Inspection of the Belt .....	97
5.5.2	Belt to Use .....	97
5.5.3	Belt Replacement .....	98
5.6	Motor Replacement Process.....	102
5.6.1	RA4C, RA6C, RA7C .....	102
5.6.2	RA8C .....	104
5.6.3	RA4R, RA6R, RA7R, RA8R .....	107
6.	External Dimensions .....	114
6.1	Standard Specification RCP6-RA4C.....	114
6.2	Built-in Controller Specification RCP6S-RA4C.....	115
6.3	Standard Specification RCP6-RA6C.....	116
6.4	Built-in Controller Specification RCP6S-RA6C.....	117
6.5	Standard Specification RCP6-RA7C.....	118
6.6	Built-in Controller Specification RCP6S-RA7C.....	119
6.7	Standard Specification RCP6-RA8C.....	120
6.8	Built-in Controller Specification RCP6S-RA8C.....	121
6.9	Standard Specification RCP6-RA4R Top Side-Mounted (Model: MT) .....	122
6.10	Standard Specification RCP6-RA4R Left Side-Mounted (Model: ML).....	123
6.11	Built-in Controller Specification RCP6S-RA4R Top Side-Mounted (Model: MT).....	124
6.12	Built-in Controller Specification RCP6S-RA4R Left Side-Mounted (Model: ML).....	125
6.13	Standard Specification RCP6-RA6R Top Side-Mounted (Model: MT).....	126
6.14	Standard Specification RCP6-RA6R Left Side-Mounted (Model: ML).....	127

6.15	Built-in Controller Specification RCP6S-RA6R Top Side-Mounted (Model: MT).....	128
6.16	Built-in Controller Specification RCP6S-RA6R Left Side-Mounted (Model: ML).....	129
6.17	Standard Specification RCP6-RA7R Top Side-Mounted (Model: MT).....	130
6.18	Standard Specification RCP6-RA7R Left Side-Mounted (Model: ML).....	131
6.19	Built-in Controller Specification RCP6S-RA7R Top Side-Mounted (Model: MT).....	132
6.20	Built-in Controller Specification RCP6S-RA7R Left Side-Mounted (Model: ML).....	133
6.21	Standard Specification RCP6-RA8R Top Side-Mounted (Model: MT).....	134
6.22	Standard Specification RCP6-RA8R Left Side-Mounted (Model: ML).....	135
6.23	Built-in Controller Specification RCP6S-RA8R Top Side-Mounted (Model: MT).....	136
6.24	Standard Specification RCP6S-RA8R Left Side-Mounted (Model: ML).....	137
7.	Life.....	138
7.1	RA4C, RA4R, RA6C, RA6R, RA7C, RA7R .....	138
7.2	RA8C, RA8R .....	138
8.	Warranty.....	139
8.1	Warranty Period.....	139
8.2	Scope of the Warranty.....	139
8.3	Honoring the Warranty .....	139
8.4	Limited Liability .....	140
8.5	Conditions of Conformance with Applicable Standards/Regulations, Etc., and Applications .....	140
8.6	Other Items Excluded from Warranty .....	140
	Change History.....	141





## Safety Guide

“Safety Guide” has been written to use the machine safely and so prevent personal injury or property damage beforehand. Make sure to read it before the operation of this product.

### Safety Precautions for Our Products

The common safety precautions for the use of any of our robots in each operation.

No.	Operation Description	Description
1	Model Selection	<ul style="list-style-type: none"> <li>• This product has not been planned and designed for the application where high level of safety is required, so the guarantee of the protection of human life is impossible. Accordingly, do not use it in any of the following applications.               <ol style="list-style-type: none"> <li>1) Medical equipment used to maintain, control or otherwise affect human life or physical health.</li> <li>2) Mechanisms and machinery designed for the purpose of moving or transporting people (For vehicle, railway facility or air navigation facility)</li> <li>3) Important safety parts of machinery (Safety device, etc.)</li> </ol> </li> <li>• Do not use the product outside the specifications. Failure to do so may considerably shorten the life of the product.</li> <li>• Do not use it in any of the following environments.               <ol style="list-style-type: none"> <li>1) Location where there is any inflammable gas, inflammable object or explosive</li> <li>2) Place with potential exposure to radiation</li> <li>3) Location with the ambient temperature or relative humidity exceeding the specification range</li> <li>4) Location where radiant heat is added from direct sunlight or other large heat source</li> <li>5) Location where condensation occurs due to abrupt temperature changes</li> <li>6) Location where there is any corrosive gas (sulfuric acid or hydrochloric acid)</li> <li>7) Location exposed to significant amount of dust, salt or iron powder</li> <li>8) Location subject to direct vibration or impact</li> </ol> </li> <li>• For an actuator used in vertical orientation, select a model which is equipped with a brake. If selecting a model with no brake, the moving part may drop when the power is turned OFF and may cause an accident such as an injury or damage on the work piece.</li> </ul>

No.	Operation Description	Description
2	Transportation	<ul style="list-style-type: none"> <li>● When carrying a heavy object, do the work with two or more persons or utilize equipment such as crane.</li> <li>● When the work is carried out with 2 or more persons, make it clear who is to be the leader and who to be the follower(s) and communicate well with each other to ensure the safety of the workers.</li> <li>● When in transportation, consider well about the positions to hold, weight and weight balance and pay special attention to the carried object so it would not get hit or dropped.</li> <li>● Transport it using an appropriate transportation measure. The actuators available for transportation with a crane have eyebolts attached or there are tapped holes to attach bolts. Follow the instructions in the instruction manual for each model.</li> <li>● Do not step or sit on the package.</li> <li>● Do not put any heavy thing that can deform the package, on it.</li> <li>● When using a crane capable of 1t or more of weight, have an operator who has qualifications for crane operation and sling work.</li> <li>● When using a crane or equivalent equipments, make sure not to hang a load that weighs more than the equipment's capability limit.</li> <li>● Use a hook that is suitable for the load. Consider the safety factor of the hook in such factors as shear strength.</li> <li>● Do not get on the load that is hung on a crane.</li> <li>● Do not leave a load hung up with a crane.</li> <li>● Do not stand under the load that is hung up with a crane.</li> </ul>
3	Storage and Preservation	<ul style="list-style-type: none"> <li>● The storage and preservation environment conforms to the installation environment. However, especially give consideration to the prevention of condensation.</li> <li>● Store the products with a consideration not to fall them over or drop due to an act of God such as earthquake.</li> </ul>
4	Installation and Start	<p>(1) Installation of Robot Main Body and Controller, etc.</p> <ul style="list-style-type: none"> <li>● Make sure to securely hold and fix the product (including the work part). A fall, drop or abnormal motion of the product may cause a damage or injury. Also, be equipped for a fall-over or drop due to an act of God such as earthquake.</li> <li>● Do not get on or put anything on the product. Failure to do so may cause an accidental fall, injury or damage to the product due to a drop of anything, malfunction of the product, performance degradation, or shortening of its life.</li> <li>● When using the product in any of the places specified below, provide a sufficient shield.             <ol style="list-style-type: none"> <li>1) Location where electric noise is generated</li> <li>2) Location where high electrical or magnetic field is present</li> <li>3) Location with the mains or power lines passing nearby</li> <li>4) Location where the product may come in contact with water, oil or chemical droplets</li> </ol> </li> </ul>

No.	Operation Description	Description
4	Installation and Start	<p>(2) Cable Wiring</p> <ul style="list-style-type: none"> <li>● Use our company's genuine cables for connecting between the actuator and controller, and for the teaching tool.</li> <li>● Do not scratch on the cable. Do not bend it forcibly. Do not pull it. Do not coil it around. Do not insert it. Do not put any heavy thing on it. Failure to do so may cause a fire, electric shock or malfunction due to leakage or continuity error.</li> <li>● Perform the wiring for the product, after turning OFF the power to the unit, so that there is no wiring error.</li> <li>● When the direct current power (+24V) is connected, take the great care of the directions of positive and negative poles. If the connection direction is not correct, it might cause a fire, product breakdown or malfunction.</li> <li>● Connect the cable connector securely so that there is no disconnection or looseness. Failure to do so may cause a fire, electric shock or malfunction of the product.</li> <li>● Never cut and/or reconnect the cables supplied with the product for the purpose of extending or shortening the cable length. Failure to do so may cause the product to malfunction or cause fire.</li> </ul> <p>(3) Grounding</p> <ul style="list-style-type: none"> <li>● The grounding operation should be performed to prevent an electric shock or electrostatic charge, enhance the noise-resistance ability and control the unnecessary electromagnetic radiation.</li> <li>● For the ground terminal on the AC power cable of the controller and the grounding plate in the control panel, make sure to use a twisted pair cable with wire thickness 0.5mm<sup>2</sup> (AWG20 or equivalent) or more for grounding work. For security grounding, it is necessary to select an appropriate wire thickness suitable for the load. Perform wiring that satisfies the specifications (electrical equipment technical standards).</li> <li>● Perform Class D Grounding (former Class 3 Grounding with ground resistance 100Ω or below).</li> </ul>





No.	Operation Description	Description
4	Installation and Start	<p>(4) Safety Measures</p> <ul style="list-style-type: none"> <li>● When the work is carried out with 2 or more persons, make it clear who is to be the leader and who to be the follower(s) and communicate well with each other to ensure the safety of the workers.</li> <li>● When the product is under operation or in the ready mode, take the safety measures (such as the installation of safety and protection fence) so that nobody can enter the area within the robot's movable range. When the robot under operation is touched, it may result in death or serious injury.</li> <li>● Make sure to install the emergency stop circuit so that the unit can be stopped immediately in an emergency during the unit operation.</li> <li>● Take the safety measure not to start up the unit only with the power turning ON. Failure to do so may start up the machine suddenly and cause an injury or damage to the product.</li> <li>● Take the safety measure not to start up the machine only with the emergency stop cancellation or recovery after the power failure. Failure to do so may result in an electric shock or injury due to unexpected power input.</li> <li>● When the installation or adjustment operation is to be performed, give clear warnings such as "Under Operation; Do not turn ON the power!" etc. Sudden power input may cause an electric shock or injury.</li> <li>● Take the measure so that the work part is not dropped in power failure or emergency stop.</li> <li>● Wear protection gloves, goggle or safety shoes, as necessary, to secure safety.</li> <li>● Do not insert a finger or object in the openings in the product. Failure to do so may cause an injury, electric shock, damage to the product or fire.</li> <li>● When releasing the brake on a vertically oriented actuator, exercise precaution not to pinch your hand or damage the work parts with the actuator dropped by gravity.</li> </ul>
5	Teaching	<ul style="list-style-type: none"> <li>● When the work is carried out with 2 or more persons, make it clear who is to be the leader and who to be the follower(s) and communicate well with each other to ensure the safety of the workers.</li> <li>● Perform the teaching operation from outside the safety protection fence, if possible. In the case that the operation is to be performed unavoidably inside the safety protection fence, prepare the "Stipulations for the Operation" and make sure that all the workers acknowledge and understand them well.</li> <li>● When the operation is to be performed inside the safety protection fence, the worker should have an emergency stop switch at hand with him so that the unit can be stopped any time in an emergency.</li> <li>● When the operation is to be performed inside the safety protection fence, in addition to the workers, arrange a watchman so that the machine can be stopped any time in an emergency. Also, keep watch on the operation so that any third person can not operate the switches carelessly.</li> <li>● Place a sign "Under Operation" at the position easy to see.</li> <li>● When releasing the brake on a vertically oriented actuator, exercise precaution not to pinch your hand or damage the work parts with the actuator dropped by gravity.</li> </ul> <p>* Safety protection Fence : In the case that there is no safety protection fence, the movable range should be indicated.</p>

No.	Operation Description	Description
6	Trial Operation	<ul style="list-style-type: none"> <li>● When the work is carried out with 2 or more persons, make it clear who is to be the leader and who to be the follower(s) and communicate well with each other to ensure the safety of the workers.</li> <li>● After the teaching or programming operation, perform the check operation one step by one step and then shift to the automatic operation.</li> <li>● When the check operation is to be performed inside the safety protection fence, perform the check operation using the previously specified work procedure like the teaching operation.</li> <li>● Make sure to perform the programmed operation check at the safety speed. Failure to do so may result in an accident due to unexpected motion caused by a program error, etc.</li> <li>● Do not touch the terminal block or any of the various setting switches in the power ON mode. Failure to do so may result in an electric shock or malfunction.</li> </ul>
7	Automatic Operation	<ul style="list-style-type: none"> <li>● Check before starting the automatic operation or rebooting after operation stop that there is nobody in the safety protection fence.</li> <li>● Before starting automatic operation, make sure that all peripheral equipment is in an automatic-operation-ready state and there is no alarm indication.</li> <li>● Make sure to operate automatic operation start from outside of the safety protection fence.</li> <li>● In the case that there is any abnormal heating, smoke, offensive smell, or abnormal noise in the product, immediately stop the machine and turn OFF the power switch. Failure to do so may result in a fire or damage to the product.</li> <li>● When a power failure occurs, turn OFF the power switch. Failure to do so may cause an injury or damage to the product, due to a sudden motion of the product in the recovery operation from the power failure.</li> </ul>

No.	Operation Description	Description
8	Maintenance and Inspection	<ul style="list-style-type: none"> <li>● When the work is carried out with 2 or more persons, make it clear who is to be the leader and who to be the follower(s) and communicate well with each other to ensure the safety of the workers.</li> <li>● Perform the work out of the safety protection fence, if possible. In the case that the operation is to be performed unavoidably inside the safety protection fence, prepare the “Stipulations for the Operation” and make sure that all the workers acknowledge and understand them well.</li> <li>● When the work is to be performed inside the safety protection fence, basically turn OFF the power switch.</li> <li>● When the operation is to be performed inside the safety protection fence, the worker should have an emergency stop switch at hand with him so that the unit can be stopped any time in an emergency.</li> <li>● When the operation is to be performed inside the safety protection fence, in addition to the workers, arrange a watchman so that the machine can be stopped any time in an emergency. Also, keep watch on the operation so that any third person can not operate the switches carelessly.</li> <li>● Place a sign “Under Operation” at the position easy to see.</li> <li>● For the grease for the guide or ball screw, use appropriate grease according to the instruction manual for each model.</li> <li>● Do not perform the dielectric strength test. Failure to do so may result in a damage to the product.</li> <li>● When releasing the brake on a vertically oriented actuator, exercise precaution not to pinch your hand or damage the work parts with the actuator dropped by gravity.</li> <li>● The slider or rod may get misaligned OFF the stop position if the servo is turned OFF. Be careful not to get injured or damaged due to an unnecessary operation.</li> <li>● Pay attention not to lose the cover or untightened screws, and make sure to put the product back to the original condition after maintenance and inspection works. Use in incomplete condition may cause damage to the product or an injury.</li> </ul> <p>* Safety protection Fence : In the case that there is no safety protection fence, the movable range should be indicated.</p>
9	Modification and Dismantle	<ul style="list-style-type: none"> <li>● Do not modify, disassemble, assemble or use of maintenance parts not specified based at your own discretion.</li> </ul>
10	Disposal	<ul style="list-style-type: none"> <li>● When the product becomes no longer usable or necessary, dispose of it properly as an industrial waste.</li> <li>● When removing the actuator for disposal, pay attention to drop of components when detaching screws.</li> <li>● Do not put the product in a fire when disposing of it. The product may burst or generate toxic gases.</li> </ul>
11	Other	<ul style="list-style-type: none"> <li>● Do not come close to the product or the harnesses if you are a person who requires a support of medical devices such as a pacemaker. Doing so may affect the performance of your medical device.</li> <li>● See Overseas Specifications Compliance Manual to check whether complies if necessary.</li> <li>● For the handling of actuators and controllers, follow the dedicated instruction manual of each unit to ensure the safety.</li> </ul>

## Alert Indication

The safety precautions are divided into “Danger”, “Warning”, “Caution” and “Notice” according to the warning level, as follows, and described in the instruction manual for each model.

Level	Degree of Danger and Damage	Symbol
Danger	This indicates an imminently hazardous situation which, if the product is not handled correctly, will result in death or serious injury.	 <b>Danger</b>
Warning	This indicates a potentially hazardous situation which, if the product is not handled correctly, could result in death or serious injury.	 <b>Warning</b>
Caution	This indicates a potentially hazardous situation which, if the product is not handled correctly, may result in minor injury or property damage.	 <b>Caution</b>
Notice	This indicates lower possibility for the injury, but should be kept to use this product properly.	 <b>Notice</b>

## Caution in Handling

---

1. Make sure to follow the usage condition, environment and specification range of the product.  
In case it is not secured, it may cause a drop in performance or malfunction of the product.
2. Do not attempt to have any handling or operation that is not stated in this Instruction manual.
3. It is recommended to apply our products for the wiring between the actuator and the controller.
4. Do not attempt to establish the settings for the speed and acceleration/deceleration above the allowable range.  
An operation with speed and acceleration/deceleration beyond the allowable range may cause an abnormal noise, vibration, malfunction or shortened life.
5. Do not apply radial load and load moment to the rod.  
Loads can only be applied in the axial direction matching with the rod axis.
6. If back and forth operations are performed repeatedly in short distance, it may wear out the film of grease.  
Continuous back and forth operation within a distance less than 30mm may cause wear of grease.  
As a reference, have approximately 5 cycles of back and forth operation in a distance more than 50mm in every 5,000 to 10,000 cycles to regenerate the oil film. Keep using the actuator with the grease worn out may cause malfunction. If it is extreme, flaking may occur on the guide, ball screw.
7. Do not attempt to hit the rod against an obstacle with high speed.  
It may destroy the coupling.
8. Make sure to attach the actuator properly by following this instruction manual.  
Using the product with the actuator not being certainly retained or affixed may cause abnormal noise, vibration, malfunction or shorten the product life.
9. Grease has been applied to the outer periphery of the rod. Protect the peripheral equipments if grease adhesion affects them.



10. For PCON-CB, RCON-PC and MCON Controllers (with option: T), it is available to switch over the setting between effective and ineffective of the high-output setting in the parameter setting.

(In the setting at delivery, the high output setting is set to effective.)

For MSEL Controller, the high output setting is effective and cannot switch it over to ineffective.

[Refer to an instruction manual for each controller for details]

The performance of weight capacity at each velocity and acceleration/deceleration setting differs between the high output setting being effective and ineffective. Refer to the applicable performance specification when the high-output setting is effective or ineffective in 1.2 Specifications.

Controller	Parameter	Remarks
PCON-CB RCON-PC	No.152 High Output Setting [0: Ineffective, 1: Effective]	
MCON	No.152 High Output Setting [0: Ineffective, 1: Effective]	Option T: In high output setting, available to have high output setting effective.

## International Standards Compliances

---

This actuator complies with the following overseas standard.

Refer to Overseas Standard Compliance Manual (ME0287) for more detailed information.

RoHS Directive	CE Marking
○	○

## Names of the Parts

In this Instruction Manual, the left and right sides are indicated by looking at the actuator from the motor end, with the actuator placed horizontally, as shown in the figure below.

1. Straight Type
  - 1.1 Standard Specification RCP6-RA4C

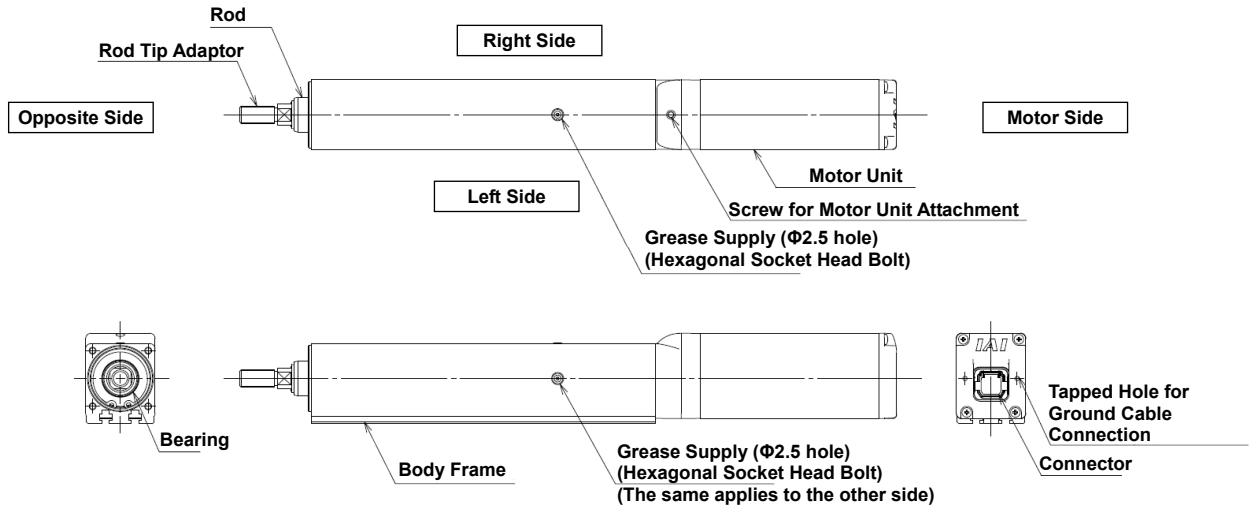

- 1.2 Built-in Controller Specification RCP6S-RA4C

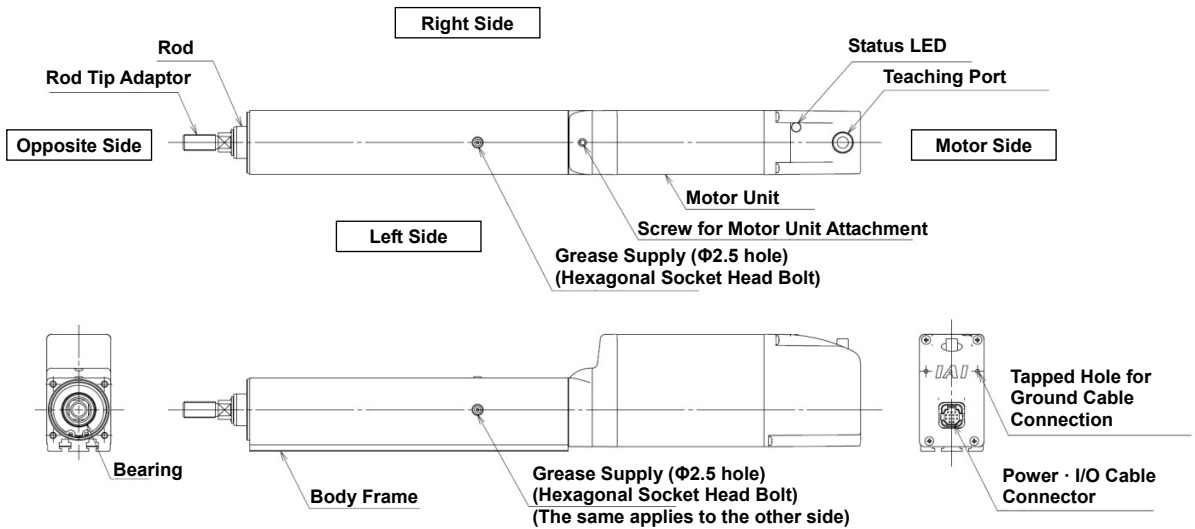

1.3 Standard Specification RCP6-RA6C, RA7C

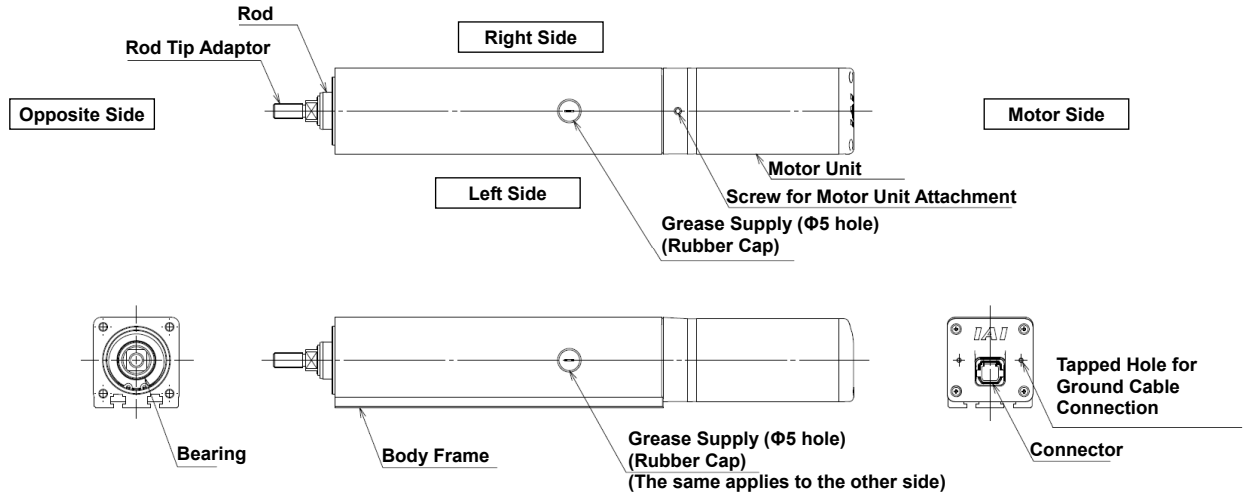

1.4 Built-in Controller Specification RCP6S-RA6C, RA7C

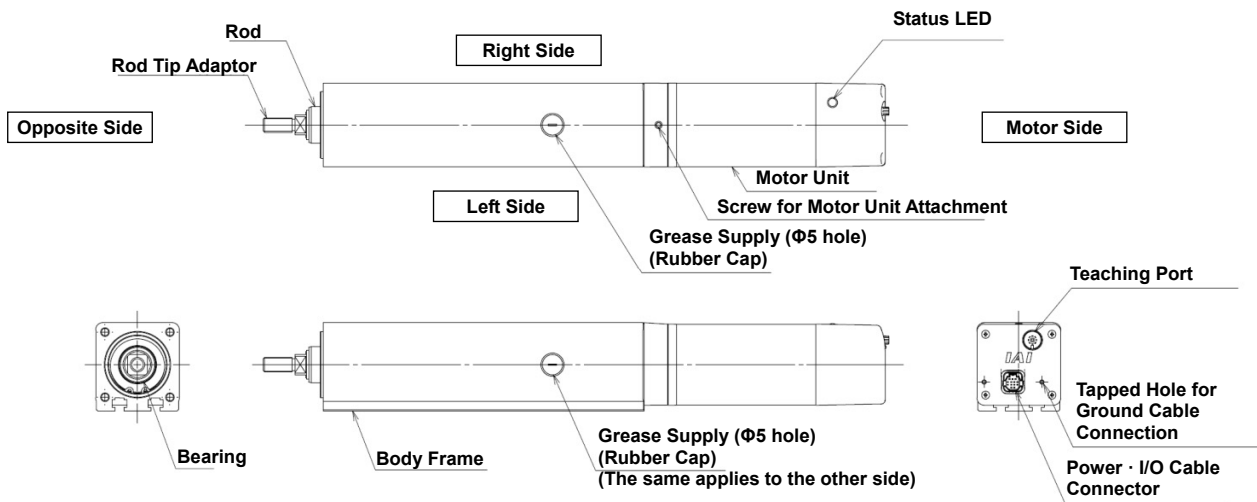

## 1.5 Standard Specification RCP6-RA8C

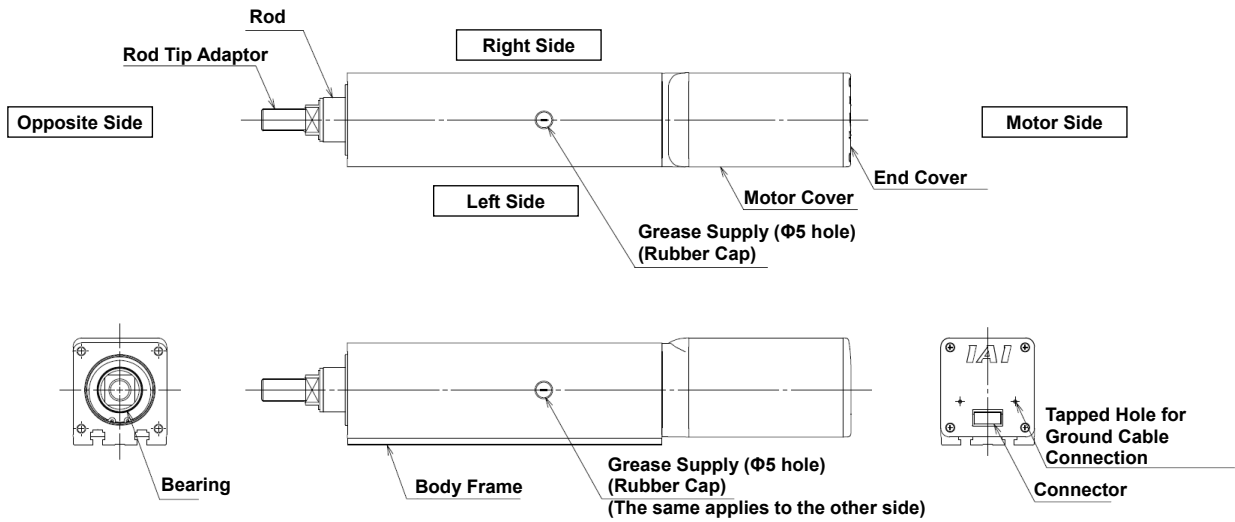

## 1.6 Built-in Controller Specification RCP6S-RA8C

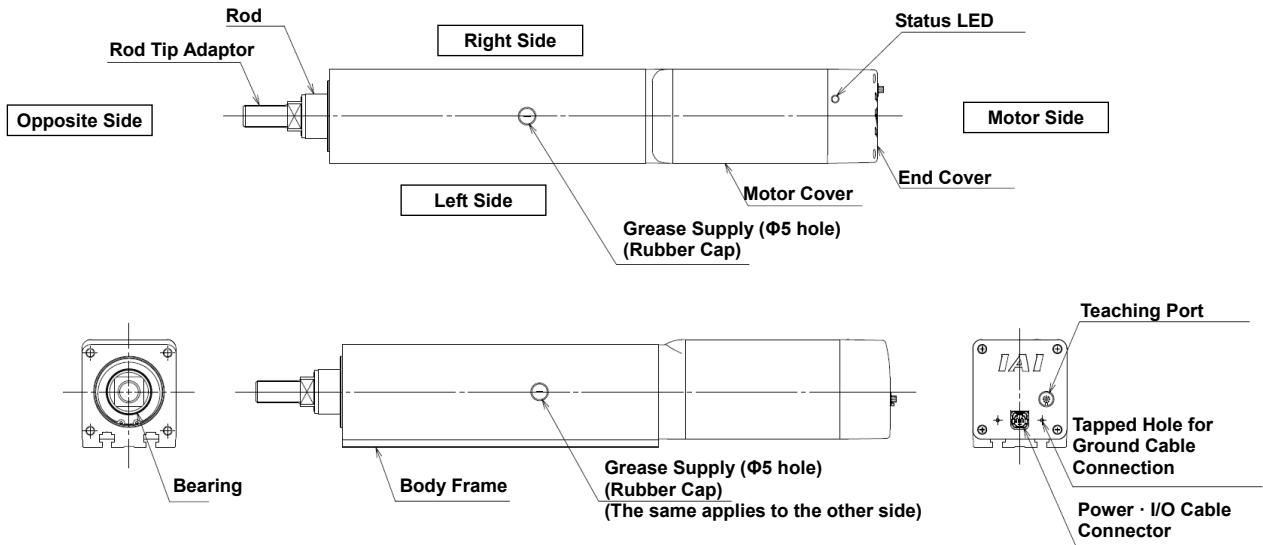

## 2. Side-Mounted Motor Type

### 2.1 Standard Specification RCP6-RA4R

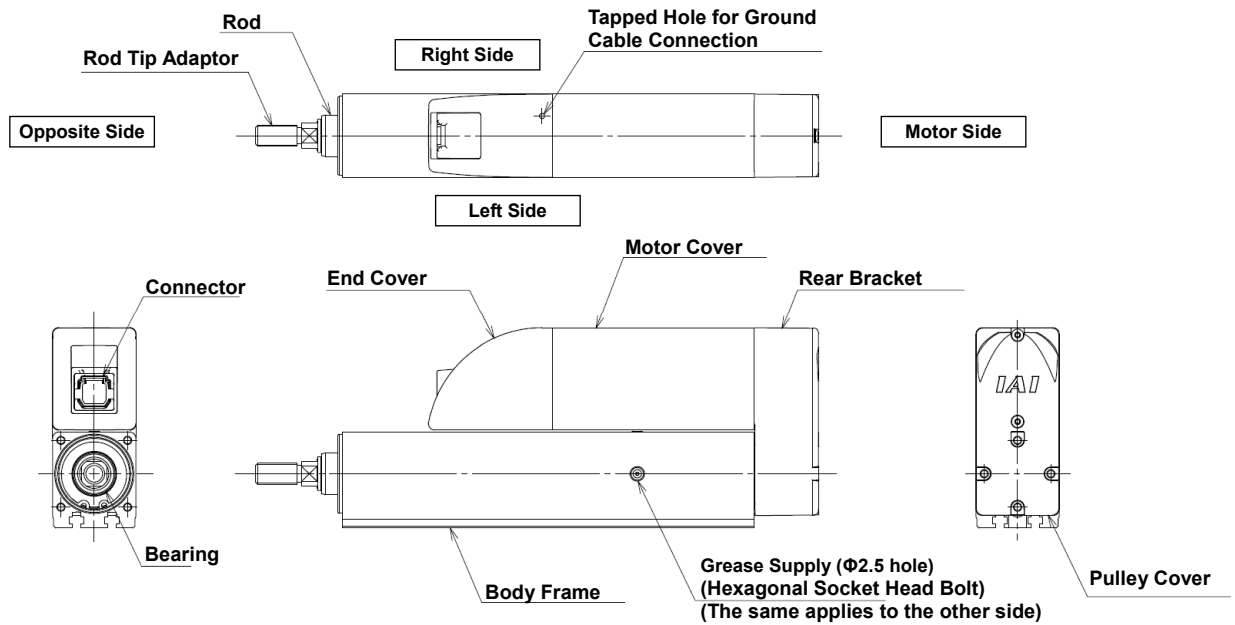

### 2.2 Built-in Controller Specification RCP6S-RA4R

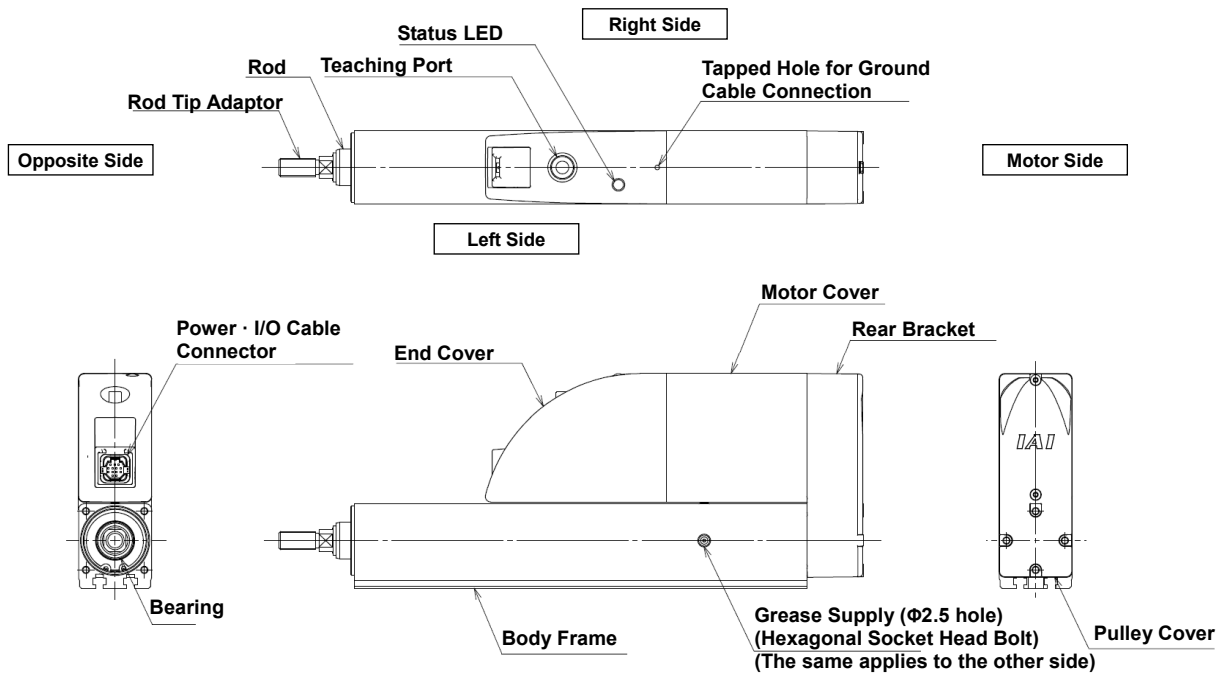

2.3 Standard Specification RCP6-RA6R, RA7R

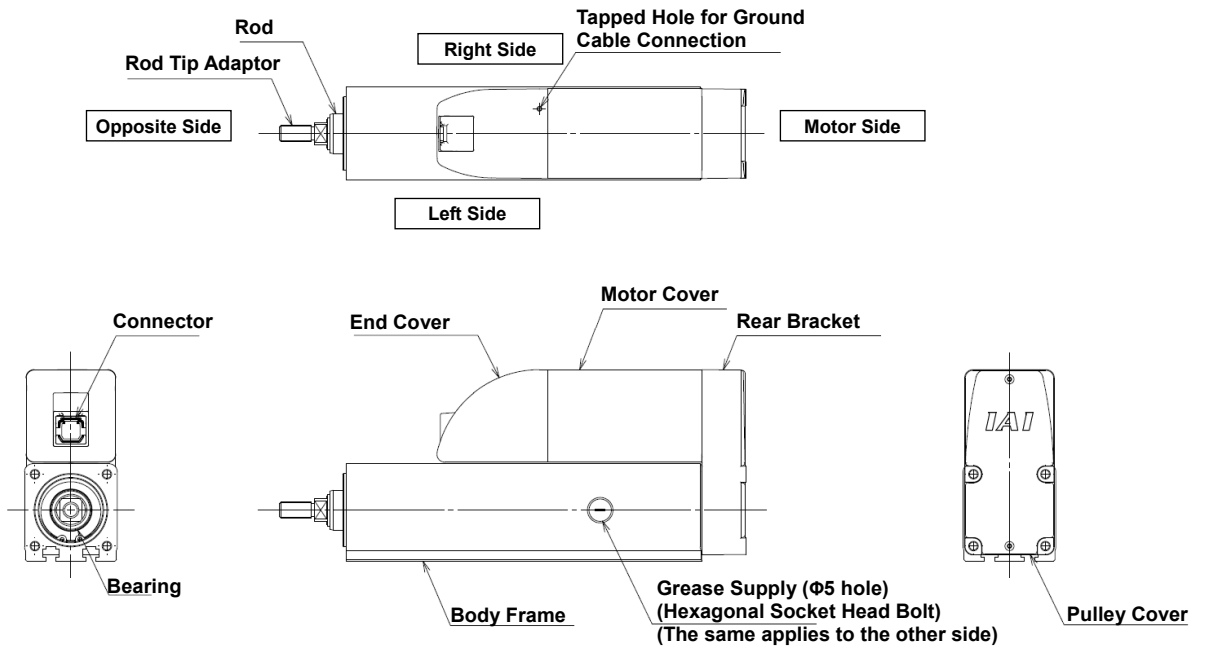

2.4 Built-in Controller Specification RCP6S-RA6R, RA7R

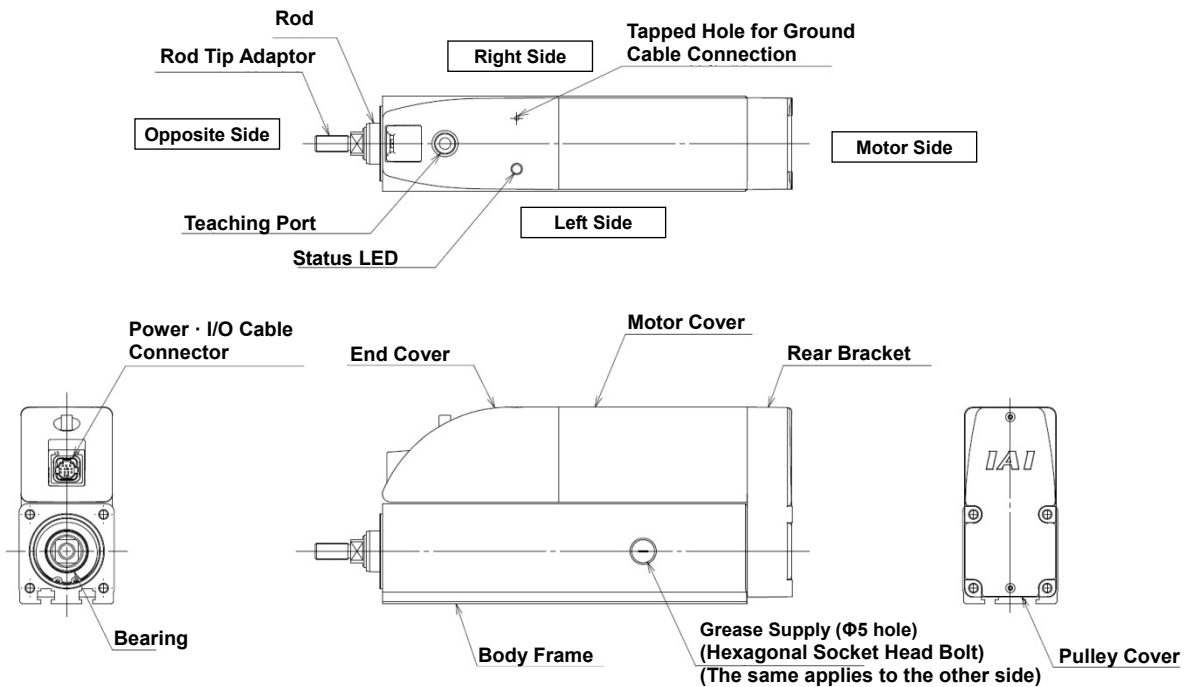

## 2.5 Standard Specification RCP6-RA8R

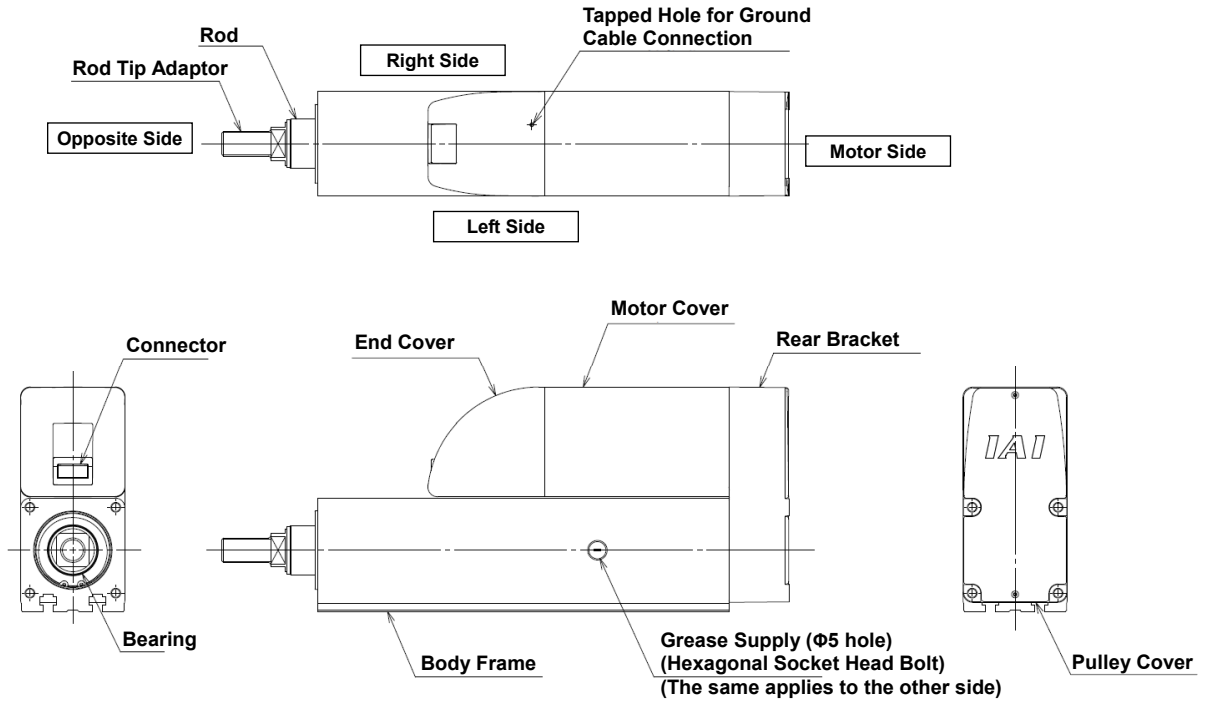

## 2.6 Built-in Controller Specification RCP6S-RA8R

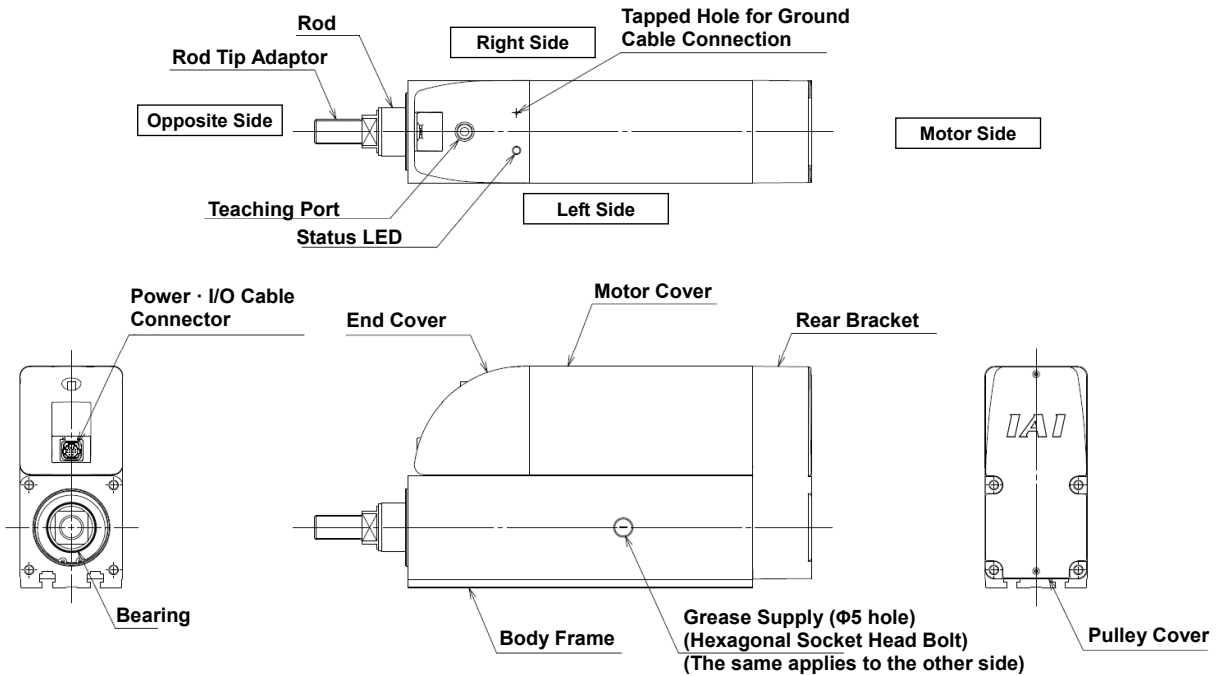

# 1. Specifications Check

## 1.1 Checking the Product

The standard configuration of this product is comprised of the following parts.  
See the component list for the details of the enclosed components. If you find any fault or missing parts, contact your local IAI distributor.

### 1.1.1 Parts

No.	Name	Model number	Quantity	Remarks
1	Actuator	Refer to "How to Read the Model Nameplate" and "How to Read the Model Number."	1	
<b>Accessories</b>				
2	Motor • Encoder Cables <sup>(Note1)</sup>		1	
3	Nut		1	Refer to list below
4	Square T-nut		1 set	Refer to list below
5	First Step Guide		1	
6	Instruction Manual (DVD)		1	
7	Safety Guide		1	

Note 1 The motor • encoder cables supplied vary depending on the controller used. [Refer to 1.4, "Motor • Encoder Cables."]

[List of Included Nut Type]

	Nut (M10×1.25)	Nut (M14×1.5)	Nut (M20×1.5)
RA4C, RA4R RA6C, RA6R	1		
RA7C, RA7R		1	
RA8C, RA8R			1

[Refer to 6. "External Dimensions" for the dimensions of nuts.]

[List of Included Square T-nut Type]

	Square T-nut	Quantity
RA4C, RA4R	M4 □7×3.2	4
RA6C, RA6R	M6 □10×5	4
RA7C, RA7R	M6 □10×5	8
RA8C, RA8R	M8 □13×6.5	8



### 1.1.2 Related Instruction Manuals for the Each Controller Supported by This Product

Shown below is a list of the instruction manuals for the controllers related to this product which is recorded in Instruction Manual (DVD).

No.	Name	Control No.
1	Instruction Manual for PCON-CB/CFB Controller	ME0342
2	Instruction Manual for MCON-C/CG Controller	ME0341
3	Instruction Manual for MSEL Controller	ME0336
4	Instruction Manual for RC PC Software RCM-101-MW/RCM-101-USB	ME0155
5	Instruction Manual for Touch Panel Teaching Pendant CON-PTA/PDA/PGA	ME0295
6	Instruction Manual for Touch Panel Teaching Pendant TB-01/01D/01DR Applicable for Position Controller	ME0324

### 1.1.3 How to Read the Model Nameplate

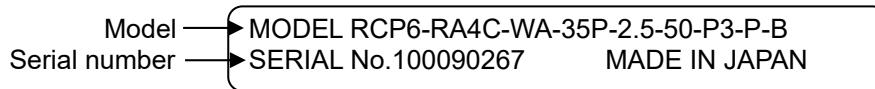

### 1.1.4 How to Read the Model Number

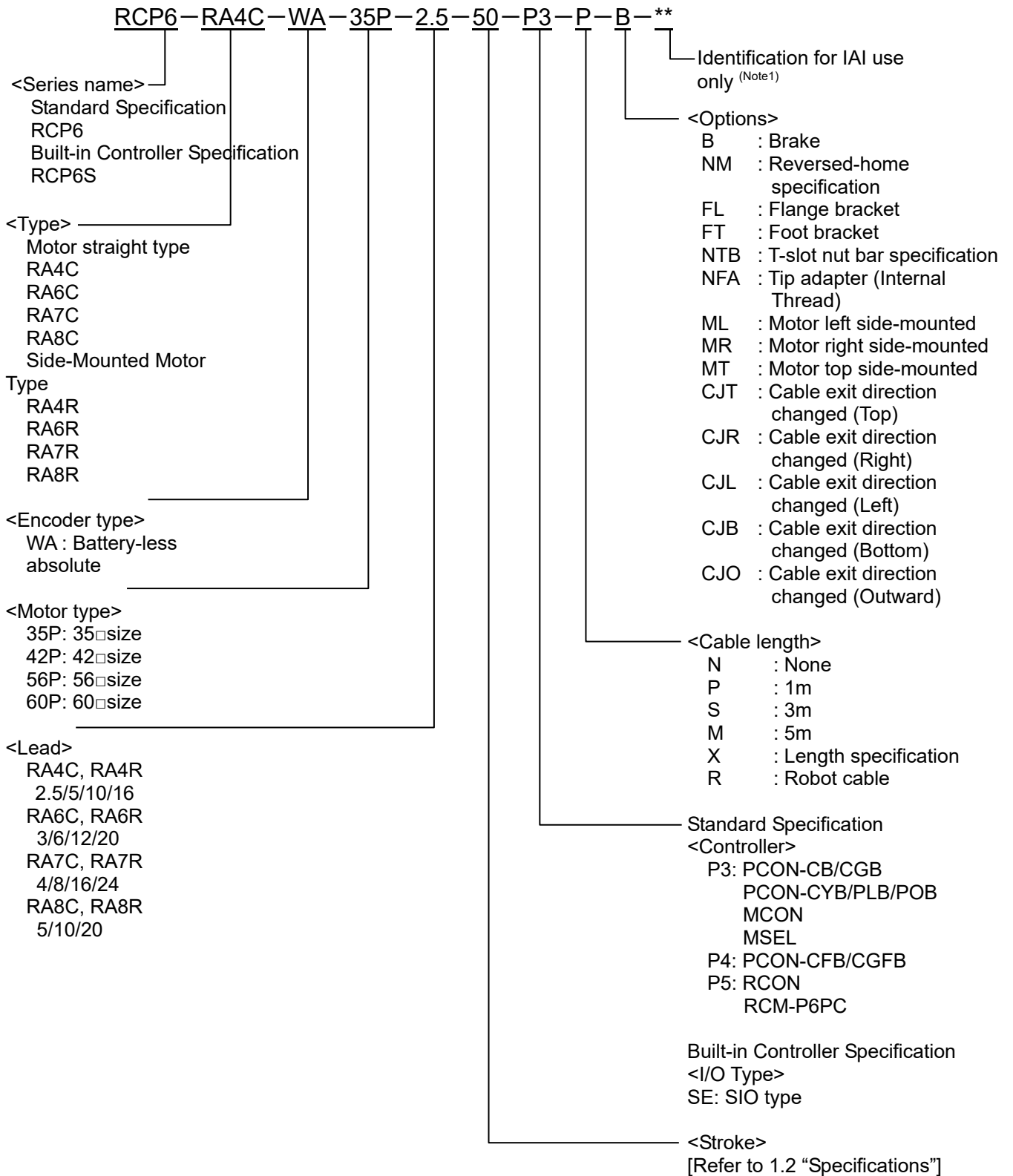

Note 1 Identification for IAI use only: It may be displayed for IAI use. It is not a code to show the model type.

## 1.2 Specifications

### 1.2.1 Speed

#### [1] Motor Straight Type

[When high-output setting is effective]

Speed limits [Unit: mm/s]

Size	Motor Type	Lead [mm]	Horizontal/ Vertical	Stroke [mm]					
				50	100	150	200	-	-
RA4C	35P	2.5	Horizontal	175			-	-	
			Vertical	175			-	-	
		5	Horizontal	350			-	-	
			Vertical	350			-	-	
		10	Horizontal	700			-	-	
			Vertical	700			-	-	
		16	Horizontal	840			-	-	
			Vertical	840			-	-	
				50	100	150	200	250	300
RA6C	42P	3	Horizontal	225					
			Vertical	225					
		6	Horizontal	450					
			Vertical	450					
		12	Horizontal	700					
			Vertical	700					
		20	Horizontal	800					
			Vertical	800					
				50	100	150	200	250	300
RA7C	56P	4	Horizontal	210					
			Vertical	175					
		8	Horizontal	420					
			Vertical	350					
		16	Horizontal	700					
			Vertical	560					
		24	Horizontal	860					
			Vertical	640					
				50	100	150	200	250	300
RA8C	60P	5	Horizontal	150					
			Vertical	150					
		10	Horizontal	300					
			Vertical	250					
		20	Horizontal	600					
			Vertical	450					

[2] Side-Mounted Motor Type

[When high-output setting is effective]

Speed limits [Unit: mm/s]

Size	Motor Type	Lead [mm]	Horizontal/ Vertical	Stroke [mm]					
				50	100	150	200	-	-
RA4R	35P	2.5	Horizontal	175			-	-	
			Vertical	175			-	-	
		5	Horizontal	350			-	-	
			Vertical	350			-	-	
		10	Horizontal	610			-	-	
			Vertical	610			-	-	
		16	Horizontal	840			-	-	
			Vertical	840			-	-	
				50	100	150	200	250	300
RA6R	42P	3	Horizontal	225					
			Vertical	225					
		6	Horizontal	450					
			Vertical	450					
		12	Horizontal	700					
			Vertical	700					
		20	Horizontal	800					
			Vertical	800					
				50	100	150	200	250	300
RA7R	56P	4	Horizontal	175					
			Vertical	175					
		8	Horizontal	420					
			Vertical	350					
		16	Horizontal	560					
			Vertical	560					
		24	Horizontal	800					
			Vertical	640					
				50	100	150	200	250	300
RA8R	60P	5	Horizontal	100					
			Vertical	100					
		10	Horizontal	200					
			Vertical	200					
		20	Horizontal	400					
			Vertical	400					

 **Caution:** When a speed less than the minimum speed, operation will not made in the set speed.  
 Do not attempt to set a speed less than the minimum speed.  
 Figure out the minimum speed using the following formula.  
 Min. Velocity [mm/s] = Lead Length [mm] / 800 / 0.001 [sec]

[3] Motor straight type

(Note) High-output settings are not available in RA8C or RA8R that operate with the PCON-CFB controller.

[When high-output setting is ineffective]

Speed limits [Unit: mm/s]

Type	Motor Type	Lead [mm]	Horizontal/ Vertical	Stroke [mm]					
				50	100	150	200	250	300
RA4C	35P	2.5	Horizontal	130			—	—	
			Vertical	130			—	—	
		5	Horizontal	260			—	—	
			Vertical	260			—	—	
		10	Horizontal	525			—	—	
			Vertical	525			—	—	
16	Horizontal	560			—	—			
	Vertical	560			—	—			
				50	100	150	200	250	300
RA6C	42P	3	Horizontal	125					
			Vertical	125					
		6	Horizontal	250					
			Vertical	250					
		12	Horizontal	500					
			Vertical	500					
20	Horizontal	640							
	Vertical	640							
				50	100	150	200	250	300
RA7C	56P	4	Horizontal	105					
			Vertical	105					
		8	Horizontal	210					
			Vertical	210					
		16	Horizontal	420					
			Vertical	280					
24	Horizontal	600							
	Vertical	400							

[4] Side-Mounted Motor Type

(Note) High-output settings are not available in RA8C or RA8R that operate with the PCON-CFB controller.

[When high-output setting is ineffective]

Speed limits [Unit: mm/s]

Type	Motor Type	Lead [mm]	Horizontal/ Vertical	Stroke [mm]					
				50	100	150	200	250	300
RA4R	35P	2.5	Horizontal	130					
			Vertical	130					
		5	Horizontal	260					
			Vertical	260					
		10	Horizontal	525					
			Vertical	525					
		16	Horizontal	560					
			Vertical	560					
				50	100	150	200	250	300
RA6R	42P	3	Horizontal	125					
			Vertical	125					
		6	Horizontal	250					
			Vertical	250					
		12	Horizontal	500					
			Vertical	500					
		20	Horizontal	640					
			Vertical	640					
				50	100	150	200	250	300
RA7R	56P	4	Horizontal	105					
			Vertical	105					
		8	Horizontal	210					
			Vertical	210					
		16	Horizontal	420					
			Vertical	280					
		24	Horizontal	600					
			Vertical	400					

 **Caution:** When a speed less than the minimum speed, operation will not be made in the set speed.  
 Do not attempt to set a speed less than the minimum speed.  
 Figure out the minimum speed using the following formula.  
 Min. Speed [mm/s] = Lead Length [mm] / 800 / 0.001 [sec]

## 1.2.2 Maximum Acceleration and Transportable Mass

If the transportable mass is smaller than as specified, the acceleration/deceleration can be raised beyond the applicable level.

### [1] Motor Straight Type

[When high-output setting for motor straight type is effective]

Type	Motor Type	Lead [mm]	Horizontal/ Vertical	Transportable Mass by Acceleration/Deceleration [kg]					
				Velocity [mm/s]	0.1G	0.3G	0.5G	0.7G	1.0G
RA4C	35P	2.5	Horizontal	0	40	40	40	35	30
				20	40	40	40	35	30
				40	40	40	40	35	30
				65	40	40	40	30	30
				85	40	40	40	30	30
				105	40	40	35	30	30
				130	40	40	35	30	30
			150	40	35	35	30	25	
			175	40	30	30	25	20	
			Vertical	0	10	10	10	-	-
				20	10	10	10	-	-
				40	10	10	10	-	-
				65	10	10	10	-	-
				85	10	10	10	-	-
		105		10	10	10	-	-	
		130		8	7.5	7	-	-	
		150	6	5.5	5	-	-		
		175	5	4.5	4	-	-		
		5	Horizontal	0	28	25	22	20	20
				40	28	25	22	20	20
				85	28	25	22	20	20
				130	28	25	22	20	20
				175	28	25	22	20	20
				215	28	25	22	20	20
				260	28	25	22	20	18
			305	28	22	20	18	15	
			350	28	20	15	13	11	
			Vertical	0	5	5	5	-	-
40	5			5	5	-	-		
85	5			5	5	-	-		
130	5			5	5	-	-		
175	5			5	5	-	-		
215	5	5		5	-	-			
260	5	5		5	-	-			
305	5	5	4.5	-	-				
350	5	4	3.5	-	-				

[When high-output setting for motor straight type is effective]

Type	Motor Type	Lead [mm]	Horizontal/ Vertical	Transportable Mass by Acceleration/Deceleration [kg]					
				Velocity [mm/s]	0.1G	0.3G	0.5G	0.7G	1.0G
RA4C	35P	10	Horizontal	0	15	15	13	13	12
				85	15	15	13	13	12
				175	15	15	13	13	12
				260	15	15	13	13	12
				350	15	15	13	13	10
				435	15	15	13	11	8
				525	-	14	10	8	6
			610	-	9	7	5	4	
			700	-	6	4	3	2	
			Vertical	0	2.5	2.5	2.5	-	-
				85	2.5	2.5	2.5	-	-
				175	2.5	2.5	2.5	-	-
				260	2.5	2.5	2.5	-	-
				350	2.5	2.5	2.5	-	-
		435		2.5	2.5	2.5	-	-	
		525		-	2.5	2.5	-	-	
		610	-	2	2	-	-		
		700	-	1.5	1.5	-	-		
		16	Horizontal	0	6	6	6	4	3.5
				140	6	6	6	4	3.5
				280	6	6	6	4	3.5
				420	6	6	6	4	3
				560	-	6	6	3	3
				700	-	5.5	5	2	1.5
				840	-	-	3	1	0.5
			Vertical	0	1.5	1.5	1.5	-	-
				140	1.5	1.5	1.5	-	-
				280	1.5	1.5	1.5	-	-
420	1			1	1	-	-		
560	-			1	1	-	-		
700	-			1	1	-	-		
840	-			-	1	-	-		



[When high-output setting for motor straight type is effective]

Type	Motor Type	Lead [mm]	Horizontal/ Vertical	Transportable Mass by Acceleration/Deceleration [kg]					
				Velocity [mm/s]	0.1G	0.3G	0.5G	0.7G	1.0G
RA6C	42P	3	Horizontal	0	60	60	50	45	40
				50	60	60	50	45	40
				75	60	60	50	45	40
				100	60	60	50	45	40
				125	60	60	50	40	30
				150	60	50	40	30	25
				175	60	40	35	25	20
				200	60	35	30	20	14
			225	40	16	16	10	6	
			Vertical	0	20	20	20	-	-
				50	20	20	20	-	-
				75	20	20	20	-	-
				100	20	20	20	-	-
				125	18	14	10	-	-
				150	14	10	6	-	-
				175	12	6	5	-	-
		200		8	5	4.5	-	-	
		225	5	5	4	-	-		
		6	Horizontal	0	40	40	35	30	25
				50	40	40	35	30	25
				100	40	40	35	30	25
				150	40	40	35	25	25
				200	40	40	30	25	20
				250	40	40	27.5	22.5	18
				300	40	35	25	20	14
				350	40	30	14	12	10
			400	30	18	10	6	5	
			450	25	8	3	-	-	
			Vertical	0	10	10	10	-	-
				50	10	10	10	-	-
				100	10	10	10	-	-
				150	10	10	10	-	-
200	10			10	10	-	-		
250	10			9	8	-	-		
300	6	6		6	-	-			
350	5	5		5	-	-			
400	4	3	3	-	-				
450	2	2	1	-	-				

[When high-output setting for motor straight type is effective]

Type	Motor Type	Lead [mm]	Horizontal/ Vertical	Transportable Mass by Acceleration/Deceleration [kg]					
				Velocity [mm/s]	0.1G	0.3G	0.5G	0.7G	1.0G
RA6C	42P	12	Horizontal	0	25	25	18	16	12
				100	25	25	18	16	12
				200	25	25	18	16	10
				300	25	25	18	12	8
				400	20	20	14	10	6
				500	15	15	8	6	4
				600	-	10	6	3	2
			700	-	6	2	-	-	
			Vertical	0	4	4	4	-	-
				100	4	4	4	-	-
				200	4	4	4	-	-
				300	4	4	4	-	-
				400	4	4	4	-	-
				500	4	3.5	3	-	-
		600		-	3	2	-	-	
		700	-	2	1	-	-		
		20	Horizontal	0	6	6	6	5	5
				160	6	6	6	5	5
				320	6	6	6	5	3
				480	6	6	6	5	3
				640	-	6	4	3	2
				800	-	4	3	-	-
			Vertical	0	1.5	1.5	1.5	-	-
				160	1.5	1.5	1.5	-	-
320	1.5			1.5	1.5	-	-		
480	1.5			1.5	1.5	-	-		
640	-	1.5	1.5	-	-				
800	-	1	1	-	-				

[When high-output setting for motor straight type is effective]

Type	Motor Type	Lead [mm]	Horizontal/ Vertical	Transportable Mass by Acceleration/Deceleration [kg]					
				Velocity [mm/s]	0.1G	0.3G	0.5G	0.7G	1.0G
RA7C	56P	4	Horizontal	0	80	80	70	65	60
				35	80	80	70	65	60
				70	80	80	70	65	60
				105	80	80	60	50	40
				140	80	50	30	20	15
				175	50	15	-	-	-
			210	20	-	-	-	-	
			Vertical	0	28	28	28	-	-
				35	28	28	28	-	-
				70	28	28	28	-	-
				105	22	22	18	-	-
				140	14	12	10	-	-
		175		5	2	-	-	-	
		210	-	-	-	-	-		
		8	Horizontal	0	60	60	50	45	40
				70	60	60	50	45	40
				140	60	60	50	45	40
				210	60	60	40	31	26
				280	60	34	20	15	11
				350	50	12	4	1	-
			420	10	-	-	-	-	
			Vertical	0	18	18	18	-	-
				70	18	18	18	-	-
				140	16	16	12	-	-
				210	10	10	9	-	-
				280	7	5	4	-	-
		350		3	2	1	-	-	
		420	-	-	-	-	-		
		16	Horizontal	0	50	50	40	35	30
				140	50	50	40	35	30
				280	50	50	35	25	20
				420	50	25	18	14	10
				560	-	10	5	3	2
				700	-	2	-	-	-
			Vertical	0	8	8	8	-	-
				140	8	8	8	-	-
280	8			7	7	-	-		
420	6			4.5	4	-	-		
560	-			2	1	-	-		
700	-			-	-	-	-		

[When high-output setting for motor straight type is effective]

Type	Motor Type	Lead [mm]	Horizontal/ Vertical	Transportable Mass by Acceleration/Deceleration [kg]					
				Velocity [mm/s]	0.1G	0.3G	0.5G	0.7G	1.0G
RA7C	56P	24	Horizontal	0	20	20	18	15	12
				200	20	20	18	15	12
				400	20	20	14	12	8
				420	20	17	12	10	6
				600	-	14	6	5	4
				640	-	5	3	2	1.5
				800	-	5	1	1	-
				860	-	2	0.5	-	-
			Vertical	0	3	3	3	-	-
				200	3	3	3	-	-
				400	3	3	3	-	-
				420	3	3	3	-	-
				600	-	3	2	-	-
				640	-	2	1	-	-
800	-	-	-	-	-	-			
860	-	-	-	-	-	-			

[Motor straight type]

In RA8C there is nothing related to high-thrust setting. There is no parameter setting.

Type	Motor Type	Lead [mm]	Horizontal/ Vertical	Transportable Mass by Acceleration/Deceleration [kg]		
				Velocity [mm/s]	0.1G	0.2G
RA8C	60P	5	Horizontal	0	100	-
				90	100	-
				120	100	-
				130	90	-
				140	75	-
				150	60	-
			Vertical	0	70	-
				48	70	-
				60	50	-
				70	35	-
				80	25	-
				90	20	-
				100	15	-
				120	10	-
		10	Horizontal	0	-	60
				150	-	60
				200	-	45
				240	-	40
				300	-	10
			Vertical	0	-	40
				88	-	40
				100	-	33
				110	-	28
				120	-	23
				130	-	18
				140	-	15
				150	-	11
				160	-	10
170	-	8				
180	-	7				
190	-	5				
200	-	4				
220	-	3				
250	-	2				

[Motor straight type]

In RA8C there is nothing related to high-thrust setting. There is no parameter setting.

Type	Motor Type	Lead [mm]	Horizontal/ Vertical	Transportable Mass by Acceleration/Deceleration [kg]		
				Velocity [mm/s]	0.1G	0.2G
RA8C	60P	20	Horizontal	0	-	30
				240	-	30
				270	-	30
				300	-	30
				360	-	24
				420	-	16
				450	-	12
				480	-	10
				510	-	8
				540	-	6
			600	-	5	
			Vertical	0	-	5
				50	-	5
				100	-	5
				150	-	5
				180	-	5
				200	-	5
				240	-	5
				300	-	5
				360	-	5
				400	-	3
420	-	2.5				
450	-	2				

 **Caution:** Do not attempt to establish the settings for the acceleration/deceleration above the allowable range. It may cause a vibration, malfunction or shorten the product life. If any acceleration/deceleration equal to or greater than the rated acceleration/deceleration is set, a creep phenomenon or slipped coupling may occur.

[2] Side-Mounted Motor Type

[When high-output setting for side-mounted motor type is effective]

Type	Motor Type	Lead [mm]	Horizontal/ Vertical	Transportable Mass by Acceleration/Deceleration [kg]					
				Velocity [mm/s]	0.1G	0.3G	0.5G	0.7G	1.0G
RA4R	35P	2.5	Horizontal	0	40	40	40	35	30
				20	40	40	40	35	30
				40	40	40	40	35	30
				65	40	40	40	30	30
				85	40	40	35	30	30
				105	40	40	35	30	30
				130	40	40	35	30	30
			150	40	35	35	30	25	
			175	40	30	30	25	20	
			Vertical	0	10	10	10	-	-
				20	10	10	10	-	-
				40	10	10	10	-	-
				65	10	10	10	-	-
				85	10	10	10	-	-
		105		10	8	8	-	-	
		130		8	8	8	-	-	
		150	6	6	6	-	-		
		175	4	4	4	-	-		
		5	Horizontal	0	25	25	22	20	18
				40	25	25	22	20	18
				85	25	25	22	20	18
				130	25	25	22	18	18
				175	25	25	22	18	16
				215	25	25	22	16	14
				260	25	22	20	14	12
			305	22	20	14	12	8	
			350	20	14	10	8	6	
			Vertical	0	5	5	5	-	-
40	5			5	5	-	-		
85	5			5	5	-	-		
130	5			5	5	-	-		
175	5			5	5	-	-		
215	5	5		5	-	-			
260	5	5		5	-	-			
305	4	4	4	-	-				
350	3	2.5	2.5	-	-				

[When high-output setting for side-mounted motor type is effective]

Type	Motor Type	Lead [mm]	Horizontal/ Vertical	Transportable Mass by Acceleration/Deceleration [kg]					
				Velocity [mm/s]	0.1G	0.3G	0.5G	0.7G	1.0G
RA4R	35P	10	Horizontal	0	12	12	10	10	8
				85	12	12	10	10	8
				175	12	12	10	10	6
				260	12	12	10	10	5
				350	12	12	10	8	5
				435	12	10	8	6	4
				525	-	8	6	3	2
			610	-	5	2	-	-	
			Vertical	0	2.5	2.5	2.5	-	-
				85	2.5	2.5	2.5	-	-
				175	2.5	2.5	2.5	-	-
				260	2.5	2.5	2.5	-	-
				350	2.5	2.5	2.5	-	-
				435	2.5	2.5	2.5	-	-
		525		-	2.5	2	-	-	
		610	-	2	1.5	-	-		
		16	Horizontal	0	5	5	4.5	3	2.5
				140	5	5	4.5	3	2.5
				280	5	5	4.5	3	2
				420	5	5	4.5	3	2
				560	-	5	4.5	2.5	2
				700	-	4.5	3.5	2	1.5
				840	-	-	2.5	1	0.5
			Vertical	0	1	1	1	-	-
				140	1	1	1	-	-
				280	1	1	1	-	-
				420	1	1	1	-	-
				560	-	1	1	-	-
700	-			1	1	-	-		
840	-			-	0.5	-	-		



[When high-output setting for side-mounted motor type is effective]

Type	Motor Type	Lead [mm]	Horizontal/ Vertical	Transportable Mass by Acceleration/Deceleration [kg]					
				Velocity [mm/s]	0.1G	0.3G	0.5G	0.7G	1.0G
RA6R	42P	3	Horizontal	0	60	60	50	45	40
				25	60	60	50	45	40
				50	60	60	50	45	40
				75	60	60	50	45	40
				100	60	60	50	45	40
				125	60	60	50	40	30
				150	60	50	40	30	25
				175	60	40	35	25	20
				200	60	35	30	20	14
			225	40	16	16	10	6	
			Vertical	0	20	20	20	-	-
				25	20	20	20	-	-
				50	20	20	20	-	-
				75	20	20	20	-	-
				100	20	20	20	-	-
				125	18	14	10	-	-
				150	14	10	6	-	-
				175	12	6	5	-	-
		200		8	5	4.5	-	-	
		225	5	5	4	-	-		
		6	Horizontal	0	40	40	35	30	25
				50	40	40	35	30	25
				100	40	40	35	30	25
				150	40	40	35	25	25
				200	40	40	30	25	20
				250	40	40	27.5	22.5	18
				300	40	35	25	20	14
				350	40	25	14	12	10
				400	30	16	10	6	5
			450	25	8	3	-	-	
			Vertical	0	10	10	10	-	-
				50	10	10	10	-	-
				100	10	10	10	-	-
				150	10	10	10	-	-
				200	10	10	10	-	-
				250	10	9	8	-	-
300	6			6	6	-	-		
350	5			5	5	-	-		
400	4	3		3	-	-			
450	2	2	1	-	-				

[When high-output setting for side-mounted motor type is effective]

Type	Motor Type	Lead [mm]	Horizontal/ Vertical	Transportable Mass by Acceleration/Deceleration [kg]					
				Velocity [mm/s]	0.1G	0.3G	0.5G	0.7G	1.0G
RA6R	42P	12	Horizontal	0	25	25	18	16	12
				100	25	25	18	16	12
				200	25	25	18	16	10
				300	25	25	18	12	8
				400	20	20	14	10	6
				500	15	15	8	6	4
				600	-	10	6	3	2
			700	-	6	2	-	-	
			Vertical	0	4	4	4	-	-
				100	4	4	4	-	-
				200	4	4	4	-	-
				300	4	4	4	-	-
				400	4	4	4	-	-
				500	4	3.5	3	-	-
		600		-	3	2	-	-	
		700	-	2	1	-	-		
		20	Horizontal	0	6	6	5	5	5
				160	6	6	5	5	5
				320	6	6	5	4	3
				480	6	6	5	4	3
				640	-	4	3	3	2
				800	-	3	2	2	1
			Vertical	0	1.5	1.5	1.5	-	-
				160	1.5	1.5	1.5	-	-
320	1.5			1.5	1.5	-	-		
480	1.5			1.5	1.5	-	-		
640	-	1.5	1.5	-	-				
800	-	1	1	-	-				

[When high-output setting for side-mounted motor type is effective]

Type	Motor Type	Lead [mm]	Horizontal/ Vertical	Transportable Mass by Acceleration/Deceleration [kg]					
				Velocity [mm/s]	0.1G	0.3G	0.5G	0.7G	1.0G
RA7R	56P	4	Horizontal	0	80	80	70	65	60
				35	80	80	70	65	60
				70	80	80	70	65	60
				105	80	80	60	50	40
				140	80	50	10	6	6
				175	40	5	-	-	-
			Vertical	0	28	28	28	-	-
				35	28	28	28	-	-
				70	28	28	28	-	-
				105	22	20	18	-	-
				140	12	8	3	-	-
				175	4	-	-	-	-
		8	Horizontal	0	60	60	50	45	40
				70	60	60	50	45	40
				140	60	60	50	45	40
				210	60	60	40	31	26
				280	60	26	16	10	8
				350	30	3	-	-	-
			Vertical	420	2	-	-	-	-
				0	18	18	18	-	-
				70	18	18	18	-	-
				140	16	16	12	-	-
				210	10	10	9	-	-
				280	8	4	3	-	-
		16	Horizontal	350	2	0.5	-	-	-
				420	-	-	-	-	-
				0	50	50	40	35	30
				140	50	50	40	35	30
				280	50	50	35	23	20
				420	50	25	18	13	10
			Vertical	560	-	10	5	3	2
				0	8	8	8	-	-
				140	8	8	8	-	-
				280	8	7	7	-	-
				420	4.5	4.5	4	-	-
				560	-	1	1	-	-

[When high-output setting for side-mounted motor type is effective]

Type	Motor Type	Lead [mm]	Horizontal/ Vertical	Transportable Mass by Acceleration/Deceleration [kg]					
				Velocity [mm/s]	0.1G	0.3G	0.5G	0.7G	1.0G
RA7R	56P	24	Horizontal	0	20	20	18	15	12
				200	20	20	18	15	12
				400	20	20	16	12	8
				420	20	20	15	10	6
				600	-	12	8	5	3
				640	-	10	6	4	2
				800	-	-	2	-	-
			Vertical	0	3	3	3	-	-
				200	3	3	3	-	-
				400	3	3	3	-	-
				420	3	3	3	-	-
				600	-	2	2	-	-
				640	-	1	1	-	-
				800	-	-	-	-	-

[When high-output setting for side-mounted motor type is effective]  
 In RA8R there is nothing related to high-thrust setting. There is no parameter setting.

Type	Motor Type	Lead [mm]	Horizontal/ Vertical	Transportable Mass by Acceleration/Deceleration [kg]		
				Velocity [mm/s]	0.1G	0.2G
RA8R	60P	5	Horizontal	0	100	-
				90	100	-
				100	75	-
			Vertical	0	70	-
				45	70	-
				60	45	-
				70	35	-
				80	25	-
				90	16	-
		10	Horizontal	100	10	-
				0	-	60
				160	-	60
				170	-	40
				180	-	25
				190	-	15
			Vertical	200	-	12
				0	-	40
				80	-	40
				90	-	34
				100	-	28
				110	-	23
				120	-	18
				130	-	15
				140	-	12
				150	-	10
				160	-	8
				170	-	6
		20	Horizontal	180	-	4
				190	-	3
				200	-	2
			Vertical	0	-	30
				300	-	30
				350	-	14
				400	-	6
				0	-	5
				300	-	5
330	-	3.5				
360	-	2				
400	-	0.5				

 **Caution:** Do not attempt to establish the settings for the acceleration/deceleration above the allowable range. It may cause a vibration, malfunction or shorten the product life. If any acceleration/deceleration equal to or greater than the rated acceleration/deceleration is set, a creep phenomenon or slipped coupling may occur.

[3] Motor Straight Type

(Note) High-output settings are not available in RA8C or RA8R that operate with the PCON-CFB controller.

[When high-output setting for motor straight type is ineffective]

Type	Motor Type	Lead [mm]	Horizontal/ Vertical	Payload by Acceleration/Deceleration [kg]		
				Velocity [mm/s]	0.3G	0.7G
RA4C	35P	2.5	Horizontal	0	35	30
				20	35	30
				40	35	30
				65	35	25
				85	30	20
				105	25	15
				130	20	10
			Vertical	0	10	—
				20	10	—
				40	10	—
				65	10	—
				85	7	—
				105	5	—
				130	4	—
		5	Horizontal	0	22	20
				40	22	20
				85	22	20
				130	22	18
				175	20	14
				215	15	10
				260	12	6
			Vertical	0	5	—
				40	5	—
				85	5	—
				130	5	—
				175	4	—
				215	3	—
				260	2	—

[When high-output setting for motor straight type is ineffective]

Type	Motor Type	Lead [mm]	Horizontal/ Vertical	Payload by Acceleration/Deceleration [kg]		
				Velocity [mm/s]	0.3G	0.7G
RA4C	35P	10	Horizontal	0	10	8
				85	10	8
				175	10	8
				260	9	7
				350	7	5
				435	6	3
			525	1	—	
			Vertical	0	2	—
				85	2	—
				175	2	—
				260	2	—
				350	1.5	—
		435		1	—	
		16	Horizontal	0	5	3
				140	5	3
				280	5	3
				420	4	2.5
				560	3	1.5
				0	1	—
			Vertical	140	1	—
				280	1	—
				420	0.5	—
				560	0.5	—

[When high-output setting for motor straight type is ineffective]

Type	Motor Type	Lead [mm]	Horizontal/ Vertical	Payload by Acceleration/Deceleration [kg]		
				Velocity [mm/s]	0.3G	0.7G
RA6C	42P	3	Horizontal	0	40	25
				50	40	25
				75	40	25
				100	40	25
				125	40	25
			Vertical	0	20	—
				50	20	—
				75	12	—
				100	9	—
				125	5	—
		6	Horizontal	0	40	20
				50	40	20
				100	40	20
				150	40	20
				200	35	18
			Vertical	250	10	6
				0	10	—
				50	10	—
				100	10	—
				150	8	—
		12	Horizontal	200	5	—
				250	3	—
				0	25	10
				100	25	10
				200	25	10
			Vertical	300	20	8
				400	10	5
				500	5	2
				0	4	—
				100	4	—
		20	Horizontal	200	4	—
				300	3	—
				400	2	—
				500	1	—
				0	6	5
			Vertical	160	6	5
				320	6	4
				480	4	3
				640	3	1
				0	1	—
		Vertical	160	1	—	
			320	1	—	
			480	1	—	
			640	0.5	—	



[When high-output setting for motor straight type is ineffective]

Type	Motor Type	Lead [mm]	Horizontal/ Vertical	Payload by Acceleration/Deceleration [kg]		
				Velocity [mm/s]	0.3G	0.7G
RA7C	56P	4	Horizontal	0	55	50
				35	55	50
				70	55	50
				105	30	15
			Vertical	0	26	—
				35	26	—
				70	13	—
				105	2	—
		8	Horizontal	0	50	30
				70	50	30
				140	50	30
				210	14	7
			Vertical	0	17.5	—
				70	17.5	—
				140	7	—
				210	2	—
		16	Horizontal	0	40	25
				140	40	25
				280	40	12
				420	1.5	1
			Vertical	0	5	—
				140	5	—
				280	2	—
				420	—	—
		24	Horizontal	0	18	9.5
				200	18	9.5
				400	11	6
				420	10	5
			Vertical	600	1	—
				0	3	—
				200	3	—
				400	1.5	—
		420	—	—		
		600	—	—		

 **Caution:** Do not attempt to establish the settings for the acceleration/deceleration above the allowable range. It may cause a vibration, malfunction or shorten the product life. If any acceleration/deceleration equal to or greater than the rated acceleration/deceleration is set, a creep phenomenon or slipped coupling may occur.

[4] Side-Mounted Motor Type

(Note) High-output settings are not available in RA8C or RA8R that operate with the PCON-CFB controller.

[When high-output setting for side-mounted motor type is ineffective]

Type	Motor Type	Lead [mm]	Horizontal/ Vertical	Payload by Acceleration/Deceleration [kg]		
				Velocity [mm/s]	0.3G	0.7G
RA4R	35P	2.5	Horizontal	0	35	30
				20	35	30
				40	35	30
				65	35	25
				85	30	20
				105	25	15
				130	20	10
			Vertical	0	10	—
				20	10	—
				40	10	—
				65	10	—
				85	7	—
				105	5	—
				130	4	—
		5	Horizontal	0	22	20
				40	22	20
				85	22	20
				130	22	18
				175	20	14
				215	15	10
				260	12	6
			Vertical	0	5	—
				40	5	—
				85	5	—
				130	5	—
				175	4	—
				215	3	—
				260	2	—

[When high-output setting for side-mounted motor type is ineffective]

Type	Motor Type	Lead [mm]	Horizontal/ Vertical	Payload by Acceleration/Deceleration [kg]		
				Velocity [mm/s]	0.3G	0.7G
RA4R	35P	10	Horizontal	0	10	8
				85	10	8
				175	10	8
				260	9	7
				350	7	5
				435	6	3
			525	1	—	
			Vertical	0	2	—
				85	2	—
				175	2	—
				260	2	—
				350	1.5	—
		435		1	—	
		16	Horizontal	0	5	3
				140	5	3
				280	5	3
				420	4	2.5
				560	3	1.5
				0	1	—
			Vertical	140	1	—
				280	1	—
				420	0.5	—
				560	0.5	—

[When high-output setting for side-mounted motor type is ineffective]

Type	Motor Type	Lead [mm]	Horizontal/ Vertical	Payload by Acceleration/Deceleration [kg]		
				Velocity [mm/s]	0.3G	0.7G
RA6R	42P	3	Horizontal	0	40	25
				25	40	25
				50	40	25
				75	40	25
				100	40	25
				125	40	25
			Vertical	0	20	—
				25	20	—
				50	20	—
				75	12	—
				100	9	—
				125	5	—
		6	Horizontal	0	40	20
				50	40	20
				100	40	20
				150	40	20
				200	35	18
				250	10	6
			Vertical	0	10	—
				50	10	—
				100	10	—
				150	8	—
				200	5	—
				250	3	—
		12	Horizontal	0	25	10
				100	25	10
				200	25	10
				300	20	8
				400	10	5
				500	5	2
			Vertical	0	4	—
				100	4	—
				200	4	—
				300	3	—
				400	2	—
				500	1	—
		20	Horizontal	0	6	5
				160	6	5
				320	6	4
				480	4	3
				640	3	1
				640	3	1
			Vertical	0	1	—
				160	1	—
				320	1	—
				480	1	—
				640	1	—
				640	0.5	—

[When high-output setting for side-mounted motor type is ineffective]

Type	Motor Type	Lead [mm]	Horizontal/ Vertical	Payload by Acceleration/Deceleration [kg]		
				Velocity [mm/s]	0.3G	0.7G
RA7R	56P	4	Horizontal	0	55	50
				35	55	50
				70	55	50
				105	30	15
			Vertical	0	26	—
				35	26	—
				70	13	—
				105	2	—
		8	Horizontal	0	50	30
				70	50	30
				140	50	30
				210	14	7
			Vertical	0	17.5	—
				70	17.5	—
				140	7	—
				210	2	—
		16	Horizontal	0	40	25
				140	40	25
				280	18	12
				420	1.5	1
			Vertical	0	5	—
				140	5	—
				280	2	—
				420	—	—
		24	Horizontal	0	18	9.5
				200	18	9.5
				400	11	6
				420	10	5
			Vertical	600	1	—
				0	3	—
				200	3	—
				400	1.5	—
		420	—	—		
		600	—	—		

 **Caution:** Do not attempt to establish the settings for the acceleration/deceleration above the allowable range. It may cause a vibration, malfunction or shorten the product life. If any acceleration/deceleration equal to or greater than the rated acceleration/deceleration is set, a creep phenomenon or slipped coupling may occur.

### 1.2.3 Driving System • Position Detector

Type	Motor Type	Lead	No. of Encoder Pulses	Ball Screw Type		
				Type	Diameter	Accuracy
RA4C RA4R	35P	2.5	8192	Rolled	φ8mm	C10
		5				
		10				
		16				
RA6C RA6R	42P	3		Rolled	φ10mm	C10
		6				
		12				
		20				
RA7C RA7R	56P	4		Rolled	φ12mm	C10
		8				
		16				
		24				
RA8C RA8R	60P	5	Rolled	φ16mm	C10	
		10				
		20				

### 1.2.4 Positioning Precision

Item	Tolerance
Positioning repeatability	±0.01mm
Lost motion	0.1mm or less

This is an option already attached when it is shipped out from the factory. It does not include the consideration of time-dependent change as it is used.

### 1.2.5 Rod Tip Load

Type	lead	Item	Tolerance
RA4C RA4R	2.5, 5, 10, 16	Rod Tip Static Allowable Torque <sup>(Note 1)</sup>	1.0N·m
		Rod Tip Maximum Displacement Angle <sup>(Note 2)</sup>	±1.0°
RA6C RA6R	3, 6, 12, 20	Rod Tip Static Allowable Torque <sup>(Note 1)</sup>	1.5N·m
		Rod Tip Maximum Displacement Angle <sup>(Note 2)</sup>	±1.0°
RA7C RA7R	4, 8, 16, 24	Rod Tip Static Allowable Torque <sup>(Note 1)</sup>	2.5N·m
		Rod Tip Maximum Displacement Angle <sup>(Note 2)</sup>	±0.8°
RA8C RA8R	5, 10, 20	Rod Tip Static Allowable Torque <sup>(Note 1)</sup>	5.0N·m
		Rod Tip Maximum Displacement Angle <sup>(Note 2)</sup>	±0.8°

Note 1 Static allowable torque around the rod center

Note 2 These are rod tip displacement angles when they are subjected to rod tip allowable torque at the position where the rod is retracted the most.

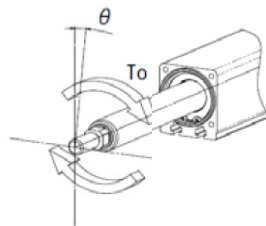

## 1.2.6 Current Limit Value and Pressing Force

### [1] RA4C and RA4R Motor Type 35P

Current Limit Value	Lead 2.5 [N]	Lead 5 [N]	Lead 10 [N]	Lead 16 [N]
20%	88	44	22	-
30%	133	66	33	21
40%	177	88	44	28
50%	221	111	55	35
60%	265	133	66	41
70%	310	155	77	48

### RA4C/R Current Limit Value and Pressing Force

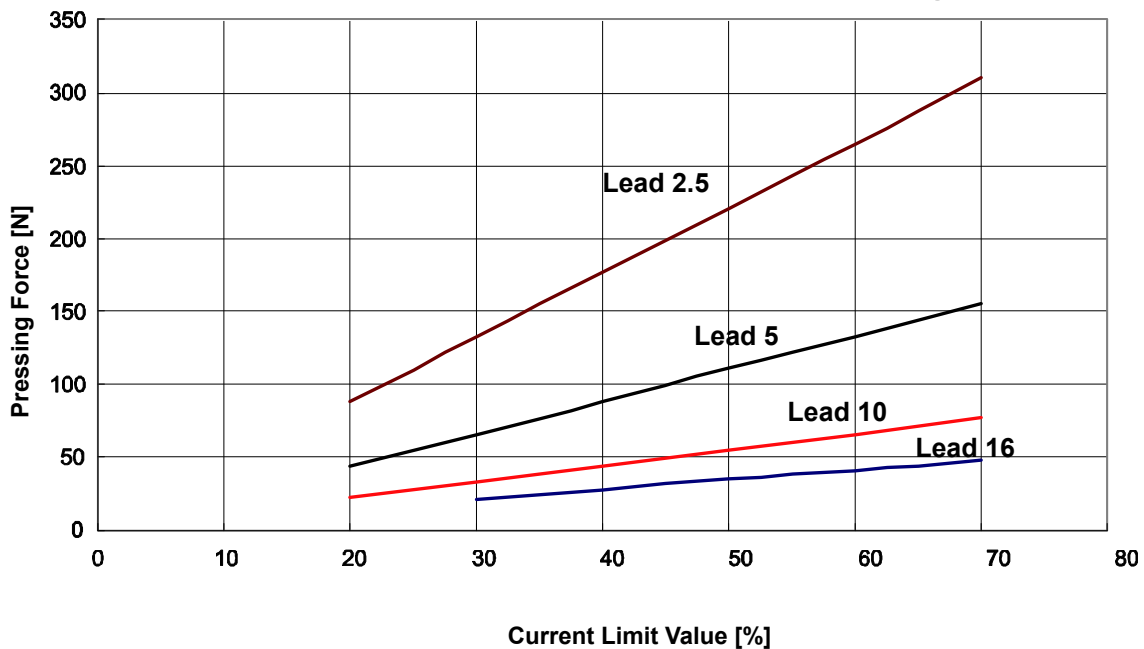

- ⚠ Caution: (1) The relation of the current limit and the pressing force is a reference when assuming the speed is 20mm/s.
- (2) There is a little variance in the actual pressing force. The variance of the pressing force becomes large when the current limit value is low.
- (3) Use the product within the range in the graph for the current limit value. Pressing force will not be stable if used below 20% (below 30% for Lead 16). There is even a case that it would not operate. An operation cannot be made also when it is beyond 70%. Doing so may cause degradation in the motor coil insulation by heat radiation, which results in shortening the product life.
- (4) For CON-system controllers such as PCON, when the approach speed to the pressing start position (setting in the position table) is 20mm/s or less, pressing will be performed with the approach speed. In such a case also the pressing force will be unstable. In such cases, check in advance that the actuator can be used with no problem before omit using.  
For SEL-system controllers, such as MSEL, press at the speed set by PAPER instruction, regardless of the approach speed up to the pressing start position.

[2] RA6C and RA6R Motor Type 42P

Current Limit Value	Lead 3 [N]	Lead 6 [N]	Lead 12 [N]	Lead 20 [N]
20%	106	53	26	16
30%	159	79	40	24
40%	211	106	53	32
50%	264	132	66	40
60%	317	159	79	48
70%	370	185	93	56

**RA6C/R Current Limit Value and Pressing Force**

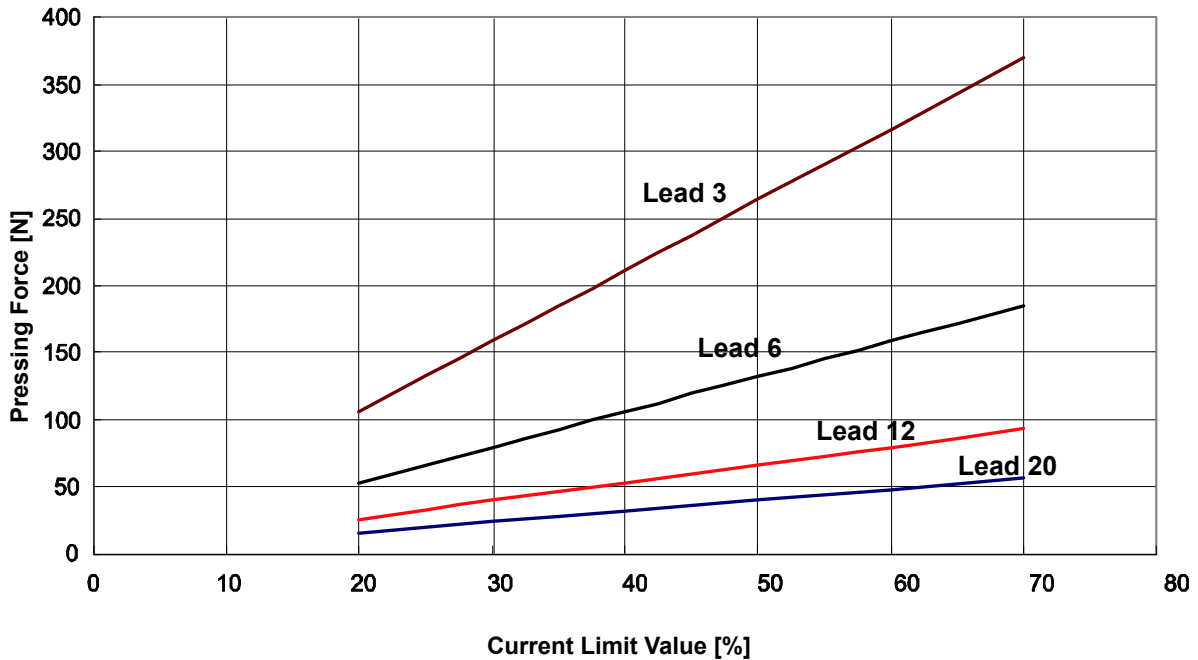

**⚠ Caution:**

- (1) The relation of the current limit and the pressing force is a reference when assuming the speed is 20mm/s.
- (2) There is a little variance in the actual pressing force. The variance of the pressing force becomes large when the current limit value is low.
- (3) Use the product within the range in the graph for the current limit value. Pressing force will not be stable if used below 20%. There is even a case that it would not operate. An operation cannot be made also when it is beyond 70%. Doing so may cause degradation in the motor coil insulation by heat radiation, which results in shortening the product life.
- (4) For CON-system controllers such as PCON, when the approach speed to the pressing start position (setting in the position table) is 20mm/s or less, pressing will be performed with the approach speed. In such a case also the pressing force will be unstable. In such cases, check in advance that the actuator can be used with no problem before omit using.  
For SEL-system controllers, such as MSEL, press at the speed set by PAPER instruction, regardless of the approach speed up to the pressing start position.



### [3] RA7C and RA7R Motor Type 56P

Current Limit Value	Lead 4 [N]	Lead 8 [N]	Lead 16 [N]	Lead 24 [N]
20%	312	156	78	52
30%	469	234	117	78
40%	625	312	156	104
50%	781	391	195	130
60%	937	469	234	156
70%	1094	547	273	182

### RA7C/R Current Limit Value and Pressing Force

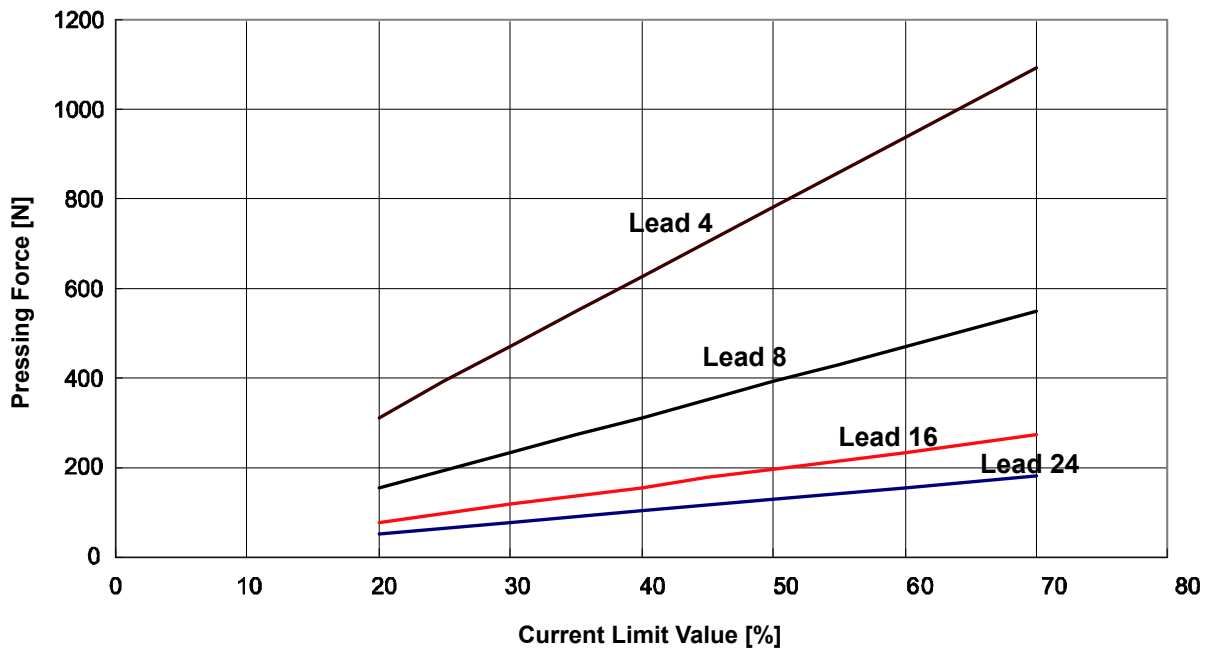

- ⚠ Caution: (1) The relation of the current limit and the pressing force is a reference when assuming the speed is 20mm/s.
- (2) There is a little variance in the actual pressing force. The variance of the pressing force becomes large when the current limit value is low.
- (3) Use the product within the range in the graph for the current limit value. Pressing force will not be stable if used below 20%. There is even a case that it would not operate. An operation cannot be made also when it is beyond 70%. Doing so may cause degradation in the motor coil insulation by heat radiation, which results in shortening the product life.
- (4) For CON-system controllers such as PCON, when the approach speed to the pressing start position (setting in the position table) is 20mm/s or less, pressing will be performed with the approach speed. In such a case also the pressing force will be unstable. In such cases, check in advance that the actuator can be used with no problem before omit using.  
For SEL-system controllers, such as MSEL, press at the speed set by PAPR instruction, regardless of the approach speed up to the pressing start position.

## [4] RA8C and RA8R Motor Type 60P

Current Limit Value	Lead 5 [N]	Lead 10 [N]	Lead 20 [N]
20%	667	333	167
30%	1000	500	250
40%	1333	667	333
50%	1667	833	417
60%	2000	1000	500

### RA8C/R Current Limit Value and Pressing Force

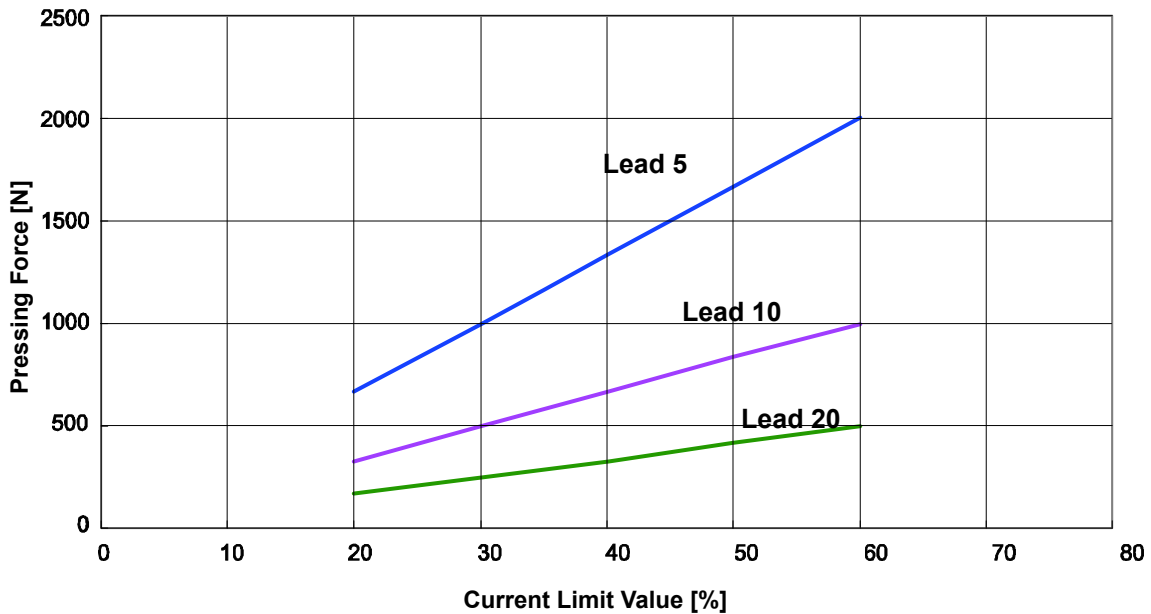

- ⚠ Caution:**
- (1) The relation of the current limit and the pressing force is a reference when assuming the speed is 10mm/s.
  - (2) There is a little variance in the actual pressing force. The variance of the pressing force becomes large when the current limit value is low.
  - (3) Use the product within the range in the graph for the current limit value. Pressing force will not be stable if used below 20%. There is even a case that it would not operate. An operation cannot be made also when it is beyond 60%. Doing so may cause degradation in the motor coil insulation by heat radiation, which results in shortening the product life.
  - (4) For CON-system controllers such as PCON, when the approach speed to the pressing start position (setting in the position table) is 10mm/s or less, pressing will be performed with the approach speed. In such a case also the pressing force will be unstable. In such cases, check in advance that the actuator can be used with no problem before omit using.  
For SEL-system controllers, such as MSEL, press at the speed set by PAPER instruction, regardless of the approach speed up to the pressing start position.

1.2.7 Rod Tip Inclination Amount (reference)

This is a calculated value from the clearances of bearing gaps and whirl-stops.

RA4C, RA4R Rod Tip Inclination Amount (Reference)

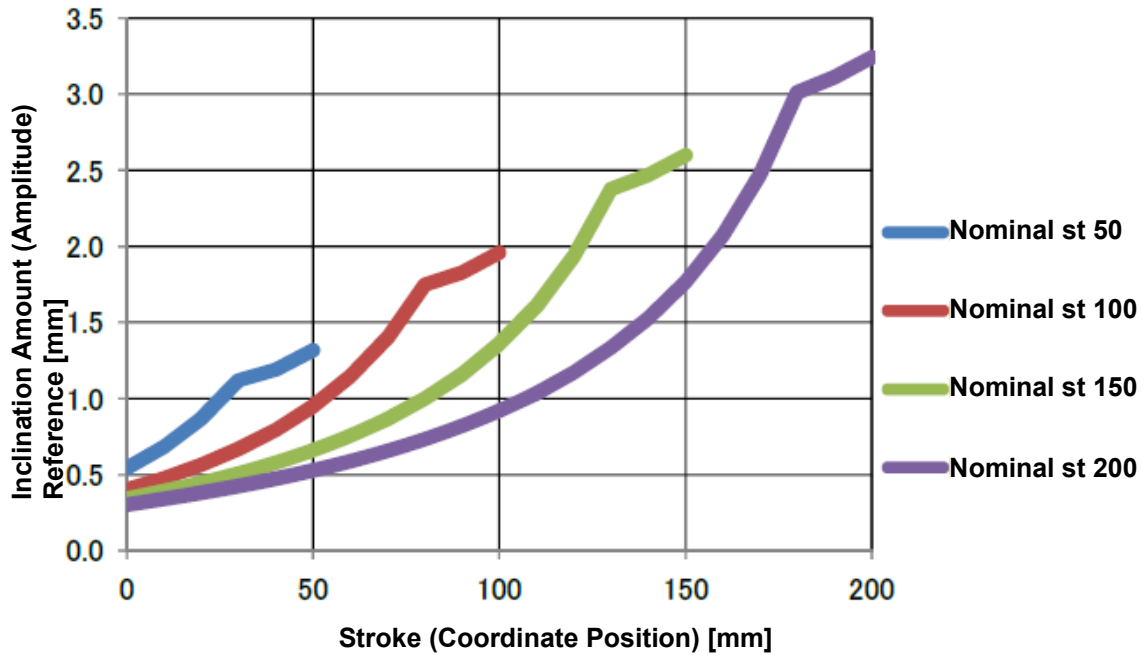

RA6C, RA6R Rod Tip Inclination Amount (Reference)

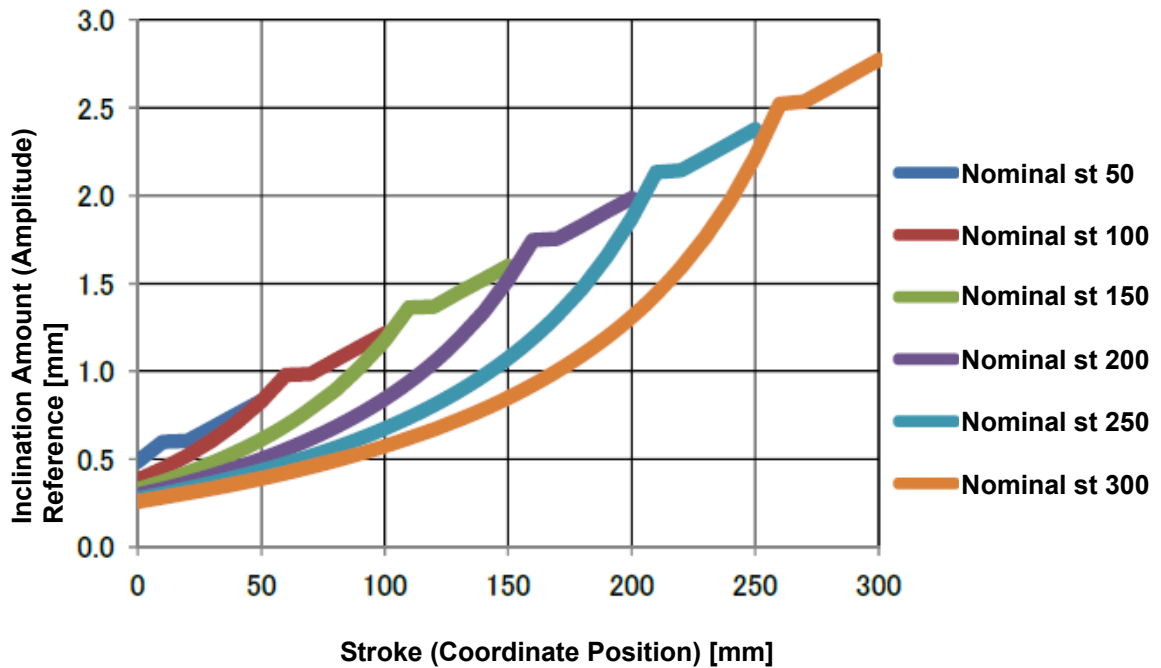

RA7C, RA7R Rod Flexure (Reference)

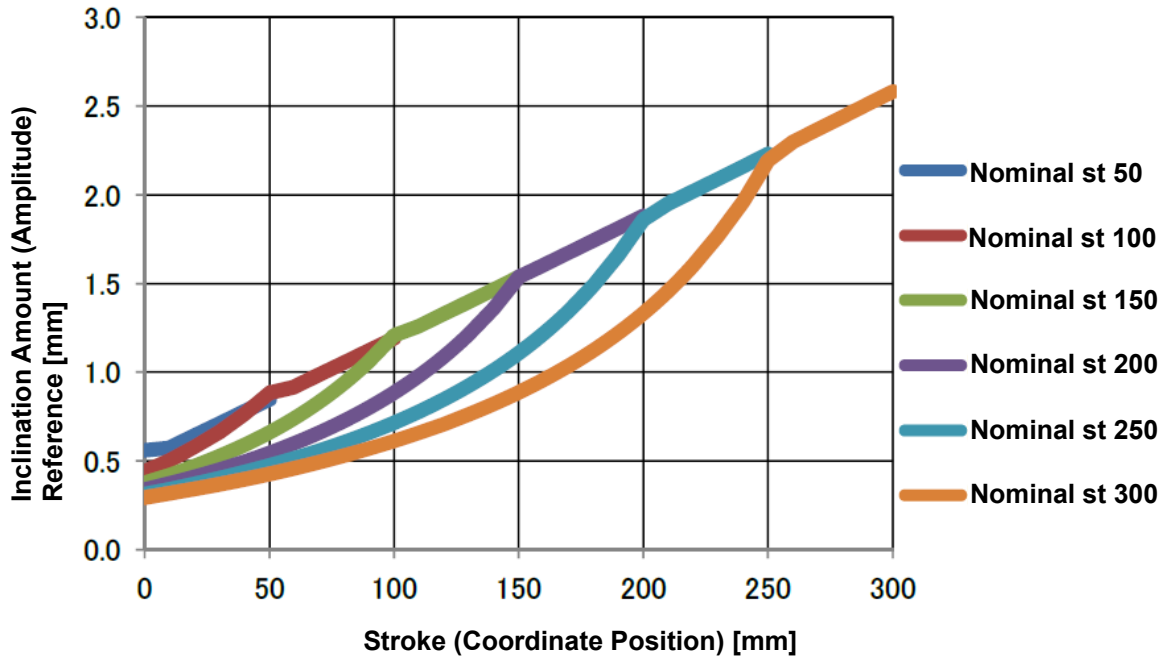

RA8C, RA8R Rod Flexure (Reference)

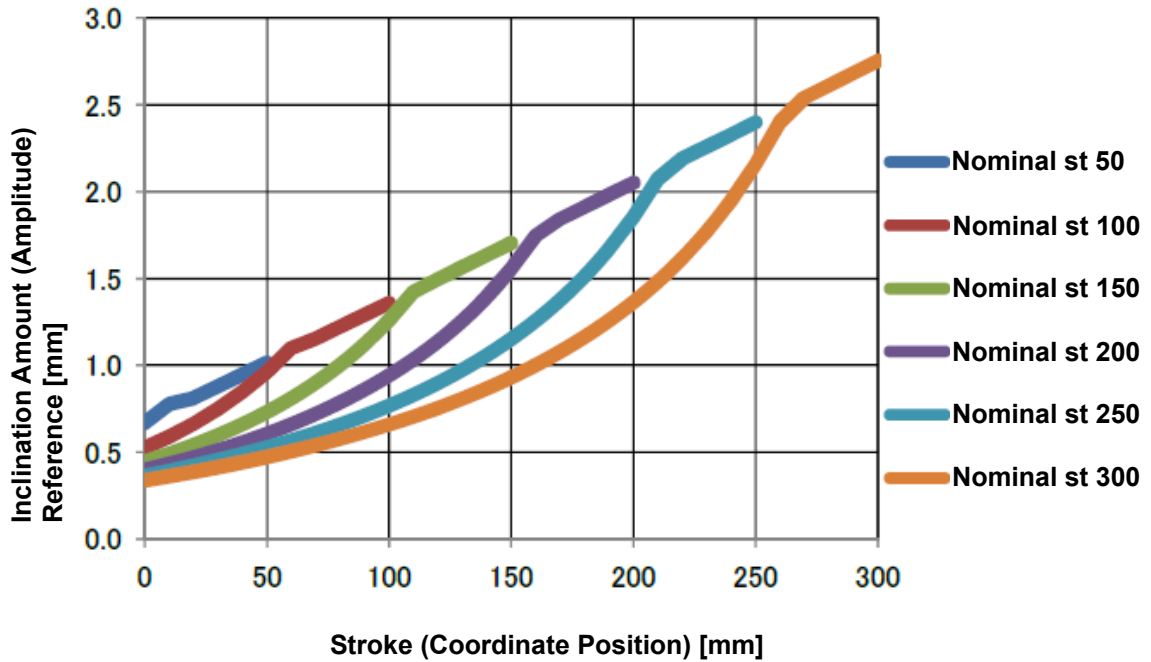

### 1.2.8 Duty Ratio for Continuous Operation

[Standard Specification]

It can operate continuously when the duty ratio is 100%.

[Standard Specification]

It can operate continuously when the duty ratio is 100%.

[Built-in Controller Specification]

© RCP6S-RA4C, 4R

It can operate continuously when the duty ratio is 100%.

© RCP6S-RA6C, 6R

Lead 12mm and 20mm can operate continuously when the duty ratio is 100%.

Operate with the duty ratio as in the following graph for lead 3mm and 6mm.

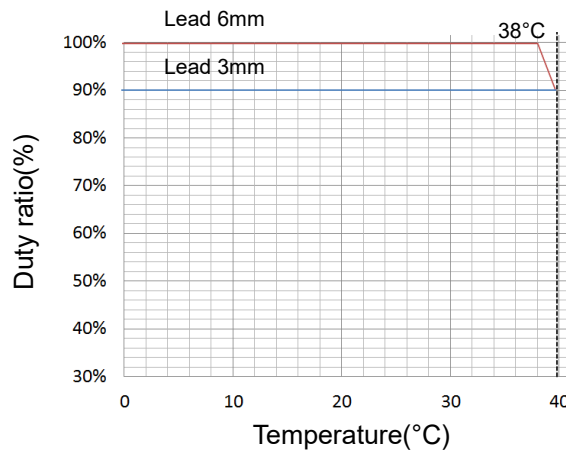

© RCP6S-RA7C, 7R

Lead 24mm can operate continuously when the duty ratio is 100%.

Operate with the duty ratio as in the following graph for lead 4mm, 8mm, and 16mm.

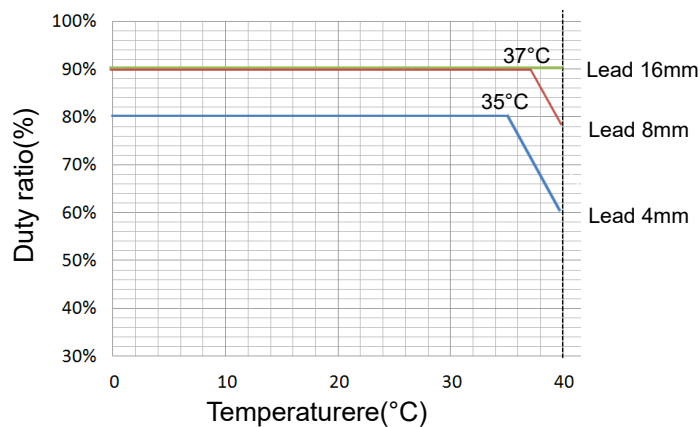

© RCP6S-RA8C, 8R

Operate with the duty ratio of 70% or less.

Duty ratio is an operating rate, which indicates the time that the actuator is running in one cycle by percentage.

## 1.3 Options

### 1.3.1 Brake Type (Model: B)

The brake is a mechanism designed to prevent the rod from dropping on a vertically installed actuator when the power or servo is turned OFF. Use the brake to prevent the installed load, etc., from being damaged due to the falling rod.

### 1.3.2 Reversed-home Specification (Model: NM)

The standard home position is on the motor side. However, the motor position will be reversed if it is desirable in view of the layout of the system, etc.

(Note) The home position is adjusted at the factory before shipment. If you wish to change the home after the delivery of your actuator, you must return the actuator to IAI for adjustment.

### 1.3.3 Flange Bracket (Front) (Model: FL)

This is the flange bracket to attach on the front of the main unit.

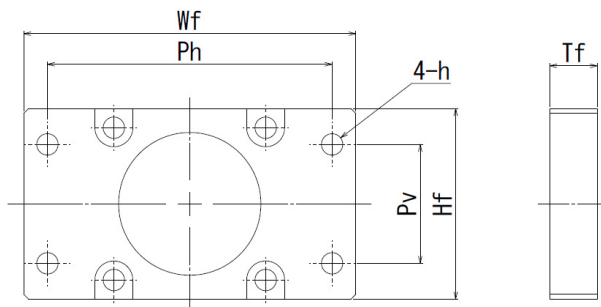

Model	RA4	RA6	RA7	RA8
Model code of single product	RCP6-FL-RA4	RCP6-FL-RA6	RCP6-FL-RA7	RCP6-FL-RA8
Wf[mm]	70	90	108	135
Hf[mm]	40	56	68	84
Ph[mm]	60	75	90	115
Pv[mm]	25	40	50	65
h[mm]	4.5	6.6	8.5	8.5
Tf[mm]	10	12	16	19

### 1.3.4 Foot Bracket (Model: FT)

This is a bracket for fixing the actuator body from the top with the bolts.  
[For the dimensions, refer to 2.3.2 “Installation of the Main Unit [2] Installation by Using Foot Brackets”]

### 1.3.5 T-slot Nut Bar (Model: NTB)

These are bar-shaped brackets that plug into the actuator's T-slots.  
There is a nut hole in the predetermined position on the T-slot nut bar.

[For the dimensions, refer to 2.3.2 “Installation of the Main Unit [1] Using the T-slot on the Bottom of the Base”]

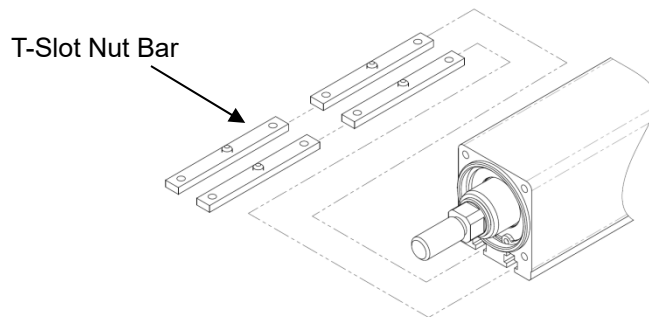

1.3.6 Tip Adapter (Internal Thread) (Model: NFA)

Applicable Units : RA4C, RA4R, RA6C, RA6R, RA7C, RA7R, RA8C, RA8R

This is an adapter to attach on the rod end an object such as a fixture with one screw.

© RA4C and RA4R

[Model code of single product : RCP6-NFA-RA4]

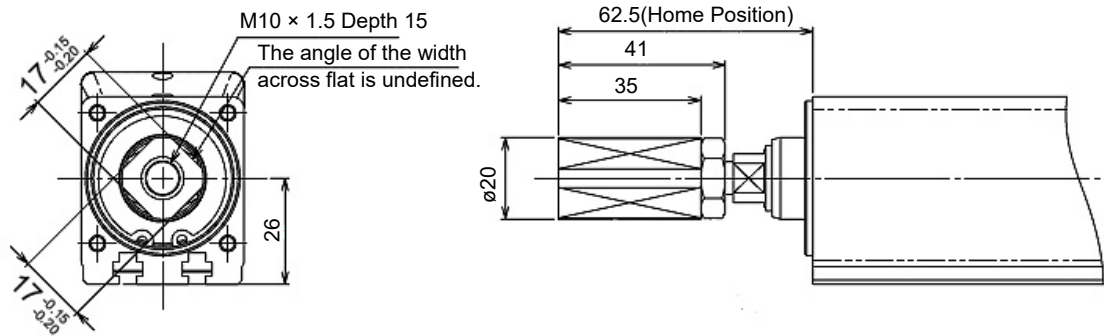

© RA6C and RA6R

[Model code of single product : RCP6-NFA-RA6]

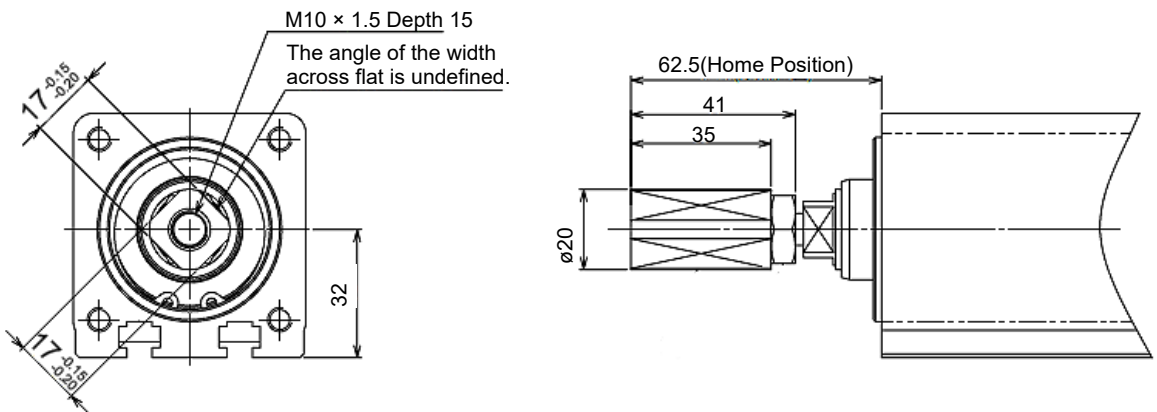



◎ RA7C and RA7R  
 [Model code of single product : RCP6-NFA-RA7]

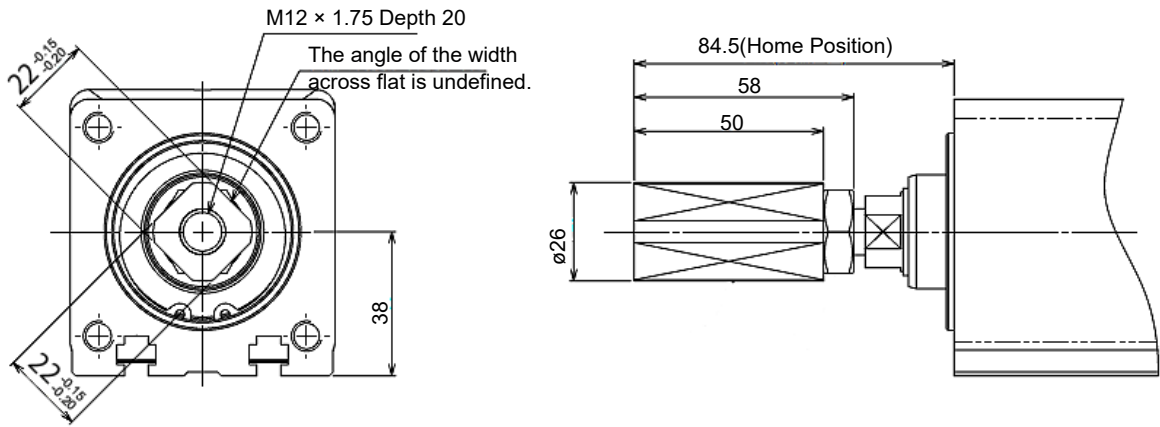

◎ RA8C and RA8R  
 [Model code of single product : RCP6-NFA-RA8]

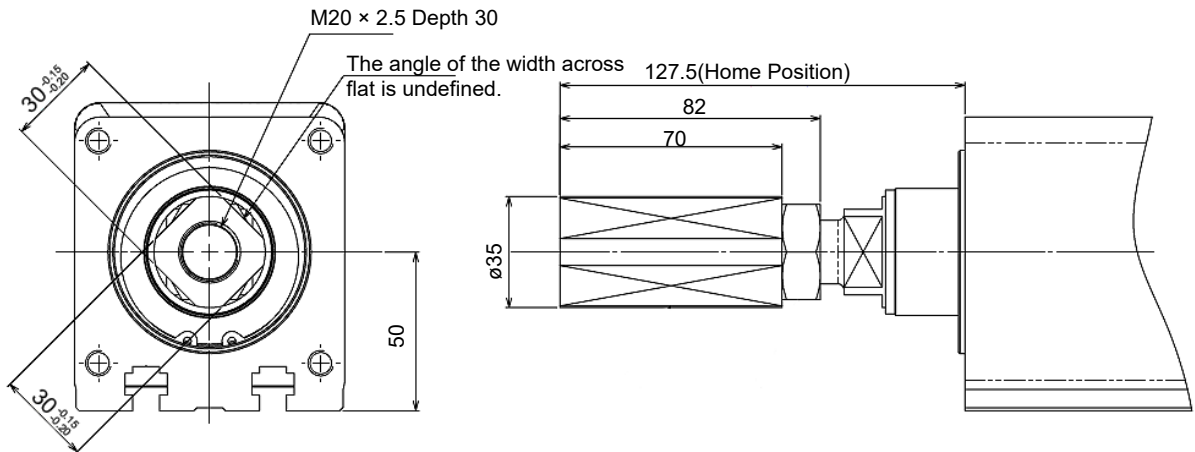

1.3.7 Motor Left Side-Mounted, Motor Top Side-Mounted, Motor Right Side-Mounted (Model: ML, MT, MR)

From the view of the motor side, the type with the motor side-mounted to the left is ML, the motor side-mounted to the top is MT, and the motor side-mounted to the right is MR.

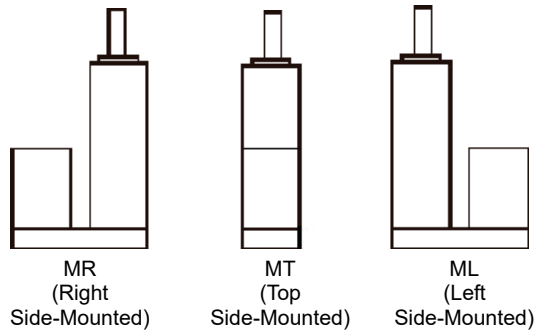

1.3.8 Cable Exit Direction Changed (Model: CJT, CJR, CJL, CJB, CJO)

If a change in the cable exit direction is made, the direction of cable exit will be changed. There are ejection directions, top (model: CJT), right (model: CJR), left (model: CJL), bottom (model: CJB) and outward (model: CJO). The side-mounted motor type of RA4R, RA6R, RA7R, and RA8R can only be selected for CJO.

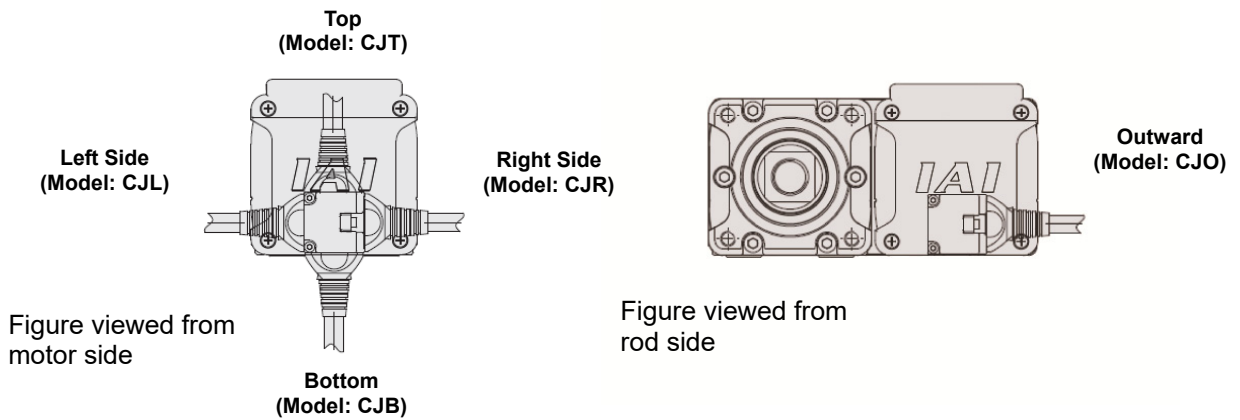

## 1.4 Motor • Encoder Cables

### 1.4.1 Dedicated connection cable for other than RCON and RCM-P6PC

#### [1] Motor • Encoder Integrated Cables (RA4, RA6 and RA7)

CB-CAN-MPA□□□ □□□ indicates the cable length (L) (Example: 030=3m), Max.20m

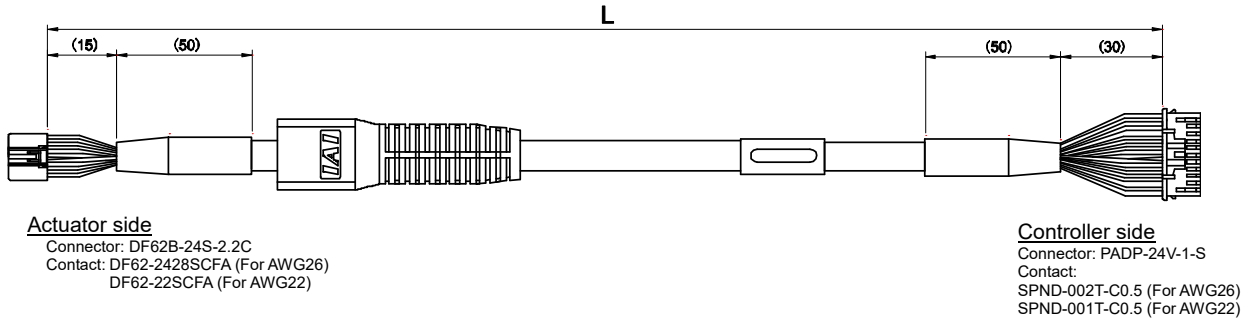

Connection diagram

Actuator side				Controller side			
Thickness	Electric Wire Color	Symbol	Pin No.	Pin No.	Symbol	Electric Wire Color	Thickness
AWG22/19	Blue	$\phi A$	3	1	$\phi A$	Blue	AWG22/19
AWG22/19	Orange	VMM	5	2	VMM	Orange	AWG22/19
AWG22/19	Brown	$\phi B$	10	3	$\phi B$	Brown	AWG22/19
AWG22/19	Gray	VMM	9	4	VMM	Gray	AWG22/19
AWG22/19	Green	$\phi_A$	4	5	$\phi_A$	Green	AWG22/19
AWG22/19	Red	$\phi_B$	15	6	$\phi_B$	Red	AWG22/19
AWG26	Black	LS+	8	7	LS+	Black	AWG26
AWG26	Yellow	LS-	14	8	LS-	Yellow	AWG26
AWG26	Blue	SA	12	11	SA	Blue	AWG26
AWG26	Orange	SB	17	12	SB	Orange	AWG26
AWG26	Green	A+	1	13	A+	Green	AWG26
AWG26	Brown	A-	6	14	A-	Brown	AWG26
AWG26	Gray	B+	11	15	B+	Gray	AWG26
AWG26	Red	B-	16	16	B-	Red	AWG26
AWG26	Blue	BK+	20	9	BK+	Blue	AWG26
AWG26	Orange	BK-	2	10	BK-	Orange	AWG26
AWG26	Gray	VCC	21	17	VCC	Gray	AWG26
AWG26	Red	GND	7	19	GND	Red	AWG26
AWG26	Brown	VPS	18	18	VPS	Brown	AWG26
AWG26	Green	LS_GND	13	20	LS_GND	Green	AWG26
-	-	-	19	22	-	-	-
AWG26	Pink	-	22	21	-	Pink	AWG26
-	-	-	23	23	-	-	-
AWG26	Black	FG	24	24	FG	Black	AWG26

(Note) About thickness AWG22/19

The thickness is AWG22 when the cable length is 5m or less, and AWG19 when longer than 5m.

## [2] Motor • Encoder Integrated Cables Robot Type (RA4, RA6 and RA7)

CB-CAN-MPA□□□-RB □□□ indicates the cable length (L) (Example: 030=3m), Max.20m

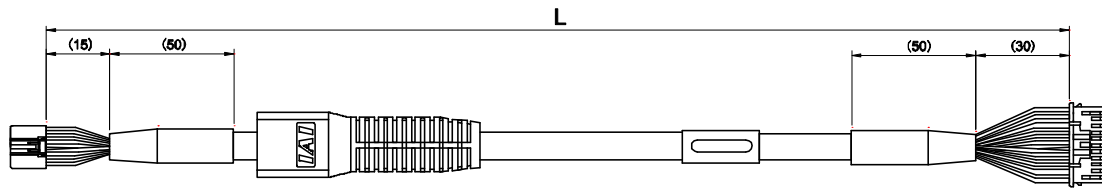

### Actuator side

Connector: DF62B-24S-2.2C  
Contact: DF62-2428SCFA (For AWG26)  
DF62-22SCFA (For AWG22)

### Controller side

Connector: PADP-24V-1-S  
Contact: SPND-002T-C0.5 (For AWG26)  
SPND-001T-C0.5 (For AWG22)

### Connection diagram

Actuator side				Controller side			
Thickness	Electric Wire Color	Symbol	Pin No.	Pin No.	Symbol	Electric Wire Color	Thickness
AWG22/19	Blue	$\phi$ A	3	1	$\phi$ A	Blue	AWG22/19
AWG22/19	Orange	VMM	5	2	VMM	Orange	AWG22/19
AWG22/19	Brown	$\phi$ B	10	3	$\phi$ B	Brown	AWG22/19
AWG22/19	Gray	VMM	9	4	VMM	Gray	AWG22/19
AWG22/19	Green	$\phi$ _A	4	5	$\phi$ _A	Green	AWG22/19
AWG22/19	Red	$\phi$ _B	15	6	$\phi$ _B	Red	AWG22/19
AWG26	Black	LS+	8	7	LS+	Black	AWG26
AWG26	Yellow	LS-	14	8	LS-	Yellow	AWG26
AWG26	Blue	SA	12	11	SA	Blue	AWG26
AWG26	Orange	SB	17	12	SB	Orange	AWG26
AWG26	Green	A+	1	13	A+	Green	AWG26
AWG26	Brown	A-	6	14	A-	Brown	AWG26
AWG26	Gray	B+	11	15	B+	Gray	AWG26
AWG26	Red	B-	16	16	B-	Red	AWG26
AWG26	Blue	BK+	20	9	BK+	Blue	AWG26
AWG26	Orange	BK-	2	10	BK-	Orange	AWG26
AWG26	Gray	VCC	21	17	VCC	Gray	AWG26
AWG26	Red	GND	7	19	GND	Red	AWG26
AWG26	Brown	VPS	18	18	VPS	Brown	AWG26
AWG26	Green	LS_GND	13	20	LS_GND	Green	AWG26
-	-	-	19	22	-	-	-
AWG26	Pink	-	22	21	-	Pink	AWG26
-	-	-	23	23	-	-	-
AWG26	Green	FG	24	24	FG	Green	AWG26

(Note) About thickness AWG22/19

The thickness is AWG22 when the cable length is 5m or less, and AWG19 when longer than 5m.

[3] Motor • Encoder Integrated Cables (RA8)

CB-CFA3-MPA□□□ □□□ indicates the cable length (L) (Example: 030=3m), Max.20m

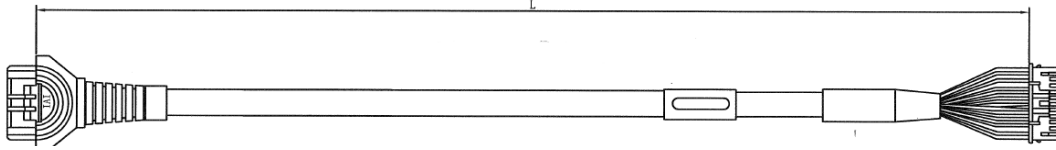

**Actuator side**  
 Connector: 1-1827863-1  
 Contact: 1827570-2

**Controller side**  
 Connector: PADP-24V-1-S  
 Contact:  
 SPND-002T-C0.5 (For AWG26)  
 SPND-001T-C0.5 (For AWG22)

Connection diagram

Actuator side				Controller side			
Thickness	Electric Wire Color	Symbol	Pin No.	Pin No.	Symbol	Electric Wire Color	Thickness
AWG22/19	Blue	$\phi$ A	A1	1	$\phi$ A	Blue	AWG22/19
AWG22/19	Orange	VMM	B1	2	VMM	Orange	AWG22/19
AWG22/19	Green	$\phi$ _A	A2	5	$\phi$ _A	Green	AWG22/19
AWG22/19	Brown	$\phi$ B	B2	3	$\phi$ B	Brown	AWG22/19
AWG22/19	Gray	VMM	A3	4	VMM	Gray	AWG22/19
AWG22/19	Red	$\phi$ _B	B3	6	$\phi$ _B	Red	AWG22/19
AWG26	Black	LS+	A4	7	LS+	Black	AWG26
AWG26	Yellow	LS-	B4	8	LS-	Yellow	AWG26
AWG26	Blue	SA	A6	11	SA	Blue	AWG26
AWG26	Orange	SB	B6	12	SB	Orange	AWG26
AWG26	Green	A+	A7	13	A+	Green	AWG26
AWG26	Brown	A-	B7	14	A-	Brown	AWG26
AWG26	Gray	B+	A8	15	B+	Gray	AWG26
AWG26	Red	B-	B8	16	B-	Red	AWG26
AWG26	Blue	BK+	A5	9	BK+	Blue	AWG26
AWG26	Orange	BK-	B5	10	BK-	Orange	AWG26
AWG26	Green	LS_GND	A9	20	LS_GND	Green	AWG26
AWG26	Brown	VPS	B9	18	VPS	Brown	AWG26
AWG26	Gray	VCC	A10	21	VCC	Gray	AWG26
AWG26	Red	GND	B10	19	GND	Red	AWG26
-	-	-	A11	17	-	-	-
AWG26	Black	FG	B11	22	-	-	AWG26
				23	-	-	-
				24	FG	Black	AWG26

(Note) About thickness AWG22/19

The thickness is AWG22 when the cable length is 3m or less, and AWG19 when longer than 3m.

## [4] Motor • Encoder Integrated Cables (RA8)

CB-CFA3-MPA□□□-RB indicates the cable length (L) (Example: 030=3m), Max.20m

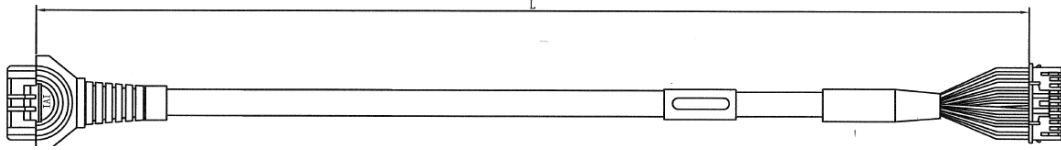

**Actuator side**  
 Connector: 1-1827863-1  
 Contact: 1827570-2

**Controller side**  
 Connector: PADP-24V-1-S  
 Contact:  
 SPND-002T-C0.5 (For AWG26)  
 SPND-001T-C0.5 (For AWG22)

Connection diagram

Actuator side				Controller side			
Thickness	Electric Wire Color	Symbol	Pin No.	Pin No.	Symbol	Electric Wire Color	Thickness
AWG22/19	Blue	$\phi$ A	A1	1	$\phi$ A	Blue	AWG22/19
AWG22/19	Orange	VMM	B1	2	VMM	Orange	AWG22/19
AWG22/19	Green	$\phi$ _A	A2	5	$\phi$ _A	Green	AWG22/19
AWG22/19	Brown	$\phi$ B	B2	3	$\phi$ B	Brown	AWG22/19
AWG22/19	Gray	VMM	A3	4	VMM	Gray	AWG22/19
AWG22/19	Red	$\phi$ _B	B3	6	$\phi$ _B	Red	AWG22/19
AWG26	Black	LS+	A4	7	LS+	Black	AWG26
AWG26	Yellow	LS-	B4	8	LS-	Yellow	AWG26
AWG26	Blue	SA	A6	11	SA	Blue	AWG26
AWG26	Orange	SB	B6	12	SB	Orange	AWG26
AWG26	Green	A+	A7	13	A+	Green	AWG26
AWG26	Brown	A-	B7	14	A-	Brown	AWG26
AWG26	Gray	B+	A8	15	B+	Gray	AWG26
AWG26	Red	B-	B8	16	B-	Red	AWG26
AWG26	Blue	BK+	A5	9	BK+	Blue	AWG26
AWG26	Orange	BK-	B5	10	BK-	Orange	AWG26
AWG26	Green	LS_GND	A9	20	LS_GND	Green	AWG26
AWG26	Brown	VPS	B9	18	VPS	Brown	AWG26
AWG26	Gray	VCC	A10	21	VCC	Gray	AWG26
AWG26	Red	GND	B10	19	GND	Red	AWG26
-	-	-	A11	17	-	-	-
AWG26	Green	FG	B11	22	-	-	AWG26
				23	-	-	-
				24	FG	Green	AWG26

(Note) About thickness AWG22/19

The thickness is AWG22 when the cable length is 3m or less, and AWG19 when longer than 3m.

### 1.4.2 Dedicated connection cable for RCON and RCM-P6PC

#### [1] Motor • Encoder Integrated Cables

CB-ADPC-MPA□□□ (□□□ indicates the cable length L, Example: 030=3m), Max.20m

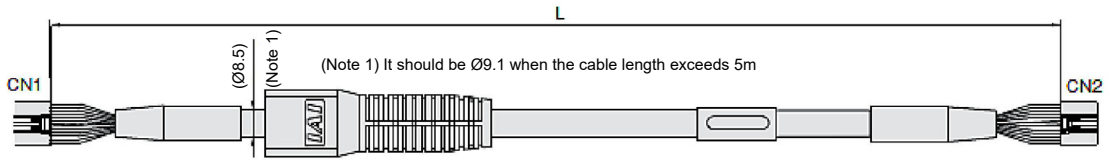

**Actuator side**  
 Connector: DF62B-24S-2.2C  
 Contact: DF62-2428SCFA  
 (For AWG26)  
 DF62-22SCFA (For AWG22)

**Controller side**  
 Connector: DF62B-24S-2.2C  
 Contact: DF62-2428SCFA  
 (For AWG26)  
 DF62-22SCFA (For AWG22)

Connection diagram

Actuator side				Controller side			
Thickness	Electric Wire Color	Symbol	Pin No.	Pin No.	Symbol	Electric Wire Color	Thickness
AWG22/19	Blue	$\phi A$	3	3	$\phi A$	Blue	AWG22/19
AWG22/19	Orange	VMM	5	5	VMM	Orange	AWG22/19
AWG22/19	Brown	$\phi B$	10	10	$\phi B$	Brown	AWG22/19
AWG22/19	Gray	VMM	9	9	VMM	Gray	AWG22/19
AWG22/19	Green	$\phi_A$	4	4	$\phi_A$	Green	AWG22/19
AWG22/19	Red	$\phi_B$	15	15	$\phi_B$	Red	AWG22/19
AWG26	Black	LS+	8	8	LS+	Black	AWG26
AWG26	Yellow	LS-	14	14	LS-	Yellow	AWG26
AWG26	Blue	SA	12	12	SA	Blue	AWG26
AWG26	Orange	SB	17	17	SB	Orange	AWG26
AWG26	Green	A+	1	1	A+	Green	AWG26
AWG26	Brown	A-	6	6	A-	Brown	AWG26
AWG26	Gray	B+	11	11	B+	Gray	AWG26
AWG26	Red	B-	16	16	B-	Red	AWG26
AWG26	Blue	BK+	20	20	BK+	Blue	AWG26
AWG26	Orange	BK-	2	2	BK-	Orange	AWG26
AWG26	Gray	VCC	21	21	VCC	Gray	AWG26
AWG26	Red	GND	7	7	GND	Red	AWG26
AWG26	Brown	VPS	18	18	VPS	Brown	AWG26
AWG26	Green	LS_GND	13	13	LS_GND	Green	AWG26
-	-	-	19	19	-	-	-
AWG26	Pink	-	22	22	-	Pink	AWG26
-	-	-	23	23	-	-	-
AWG26	Black	FG	24	24	FG	Black	AWG26

(Note) About thickness AWG22/19

The thickness is AWG22 when the cable length is 5m or less, and AWG19 when longer than 5m.

## [2] Motor • Encoder Integrated Cables Robot Type

CB-ADPC-MPA□□□-RB (□□□ indicates the cable length L, Example: 030=3m), Max.20m

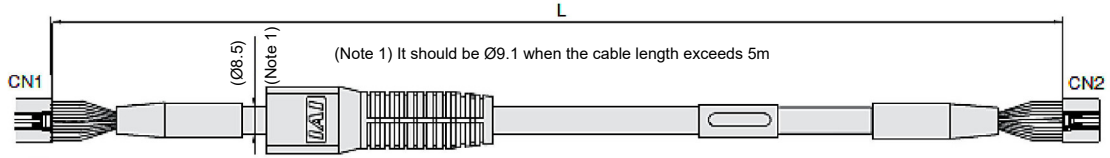

### Actuator side

Connector: DF62B-24S-2.2C  
 Contact: DF62-2428SCFA  
 (For AWG26)  
 DF62-22SCFA (For AWG22)

### Controller side

Connector: DF62B-24S-2.2C  
 Contact: DF62-2428SCFA  
 (For AWG26)  
 DF62-22SCFA (For AWG22)

### Connection diagram

Actuator side				Controller side			
Thickness	Electric Wire Color	Symbol	Pin No.	Pin No.	Symbol	Electric Wire Color	Thickness
AWG22/19	Blue	$\phi$ A	3	3	$\phi$ A	Blue	AWG22/19
AWG22/19	Orange	VMM	5	5	VMM	Orange	AWG22/19
AWG22/19	Brown	$\phi$ B	10	10	$\phi$ B	Brown	AWG22/19
AWG22/19	Gray	VMM	9	9	VMM	Gray	AWG22/19
AWG22/19	Green	$\phi$ _A	4	4	$\phi$ _A	Green	AWG22/19
AWG22/19	Red	$\phi$ _B	15	15	$\phi$ _B	Red	AWG22/19
AWG26	Black	LS+	8	8	LS+	Black	AWG26
AWG26	Yellow	LS-	14	14	LS-	Yellow	AWG26
AWG26	Blue	SA	12	12	SA	Blue	AWG26
AWG26	Orange	SB	17	17	SB	Orange	AWG26
AWG26	Green	A+	1	1	A+	Green	AWG26
AWG26	Brown	A-	6	6	A-	Brown	AWG26
AWG26	Gray	B+	11	11	B+	Gray	AWG26
AWG26	Red	B-	16	16	B-	Red	AWG26
AWG26	Blue	BK+	20	20	BK+	Blue	AWG26
AWG26	Orange	BK-	2	2	BK-	Orange	AWG26
AWG26	Gray	VCC	21	21	VCC	Gray	AWG26
AWG26	Red	GND	7	7	GND	Red	AWG26
AWG26	Brown	VPS	18	18	VPS	Brown	AWG26
AWG26	Green	LS_GND	13	13	LS_GND	Green	AWG26
-	-	-	19	19	-	-	-
AWG26	Pink	-	22	22	-	Pink	AWG26
-	-	-	23	23	-	-	-
AWG26	Green	FG	24	24	FG	Green	AWG26

(Note) About thickness AWG22/19

The thickness is AWG22 when the cable length is 5m or less, and AWG19 when longer than 5m.



## [3] Conversion Cable CB-CAN-AJ002 length 0.2m

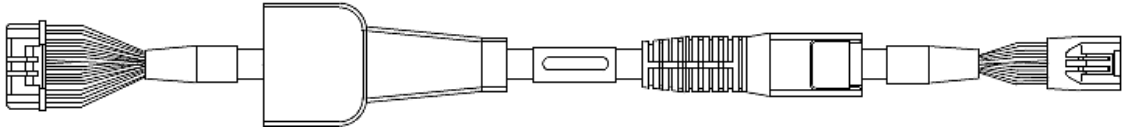

**Actuator side**  
Connector: 1-1827863-1  
Contact: 1827570-2

**Controller side**  
Connector: DF62B-24EP-2.2C  
Contact:  
DF62-EP2428PCFA (For AWG26)  
DF62-EP22PCFA (For AWG22)

Connection diagram

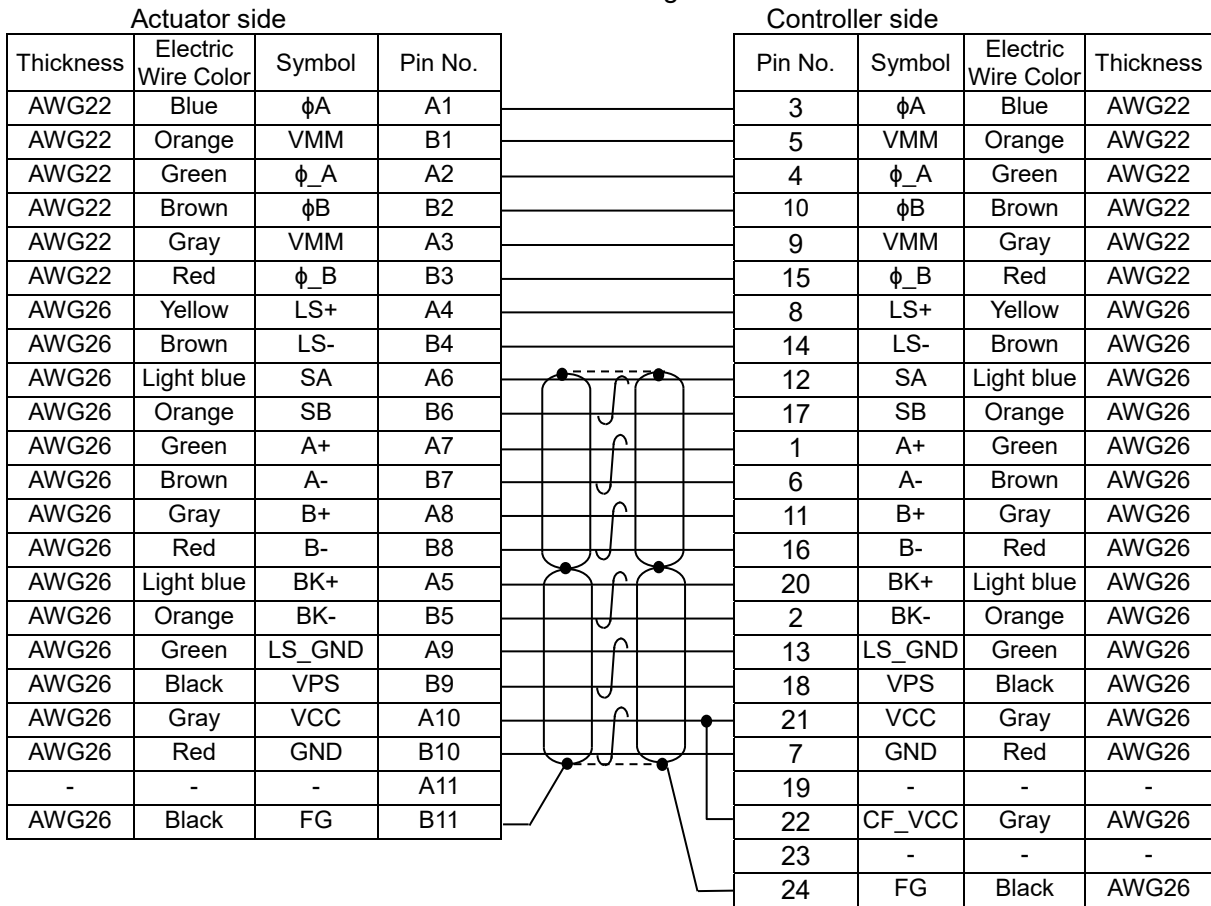

## 2. Installation

### 2.1 Transportation

#### [1] Handling of Robot

##### (1) Handling the Packed Unit

Unless otherwise specified, the actuator is shipped with each axis packaged separately.

- Do not damage or drop. No special treatment is conducted on this package to endure a drop or impact on it.
- Do not attempt to carry a heavy package with only one worker. Consider an appropriate method for transportation.
- Keep the unit in horizontal orientation when placing it on the ground or transporting. Follow the instruction if there is any for the packaging condition.
- Do not step or sit on the package.
- Do not put any load that may cause a deformation or breakage of the package.

##### (2) Handling the Actuator After Unpacking

- Do not carry an actuator by motor unit and a cable or attempt to move it by pulling the cable.
- Be careful not to bump the actuator into anything when moving it.
- Hold the body base when transporting the actuator.
- Do not apply an excessive force to each part of the actuator.

Supplement) For the names of each part of the actuator, refer to “Names of the Parts”

## [2] Handling in the Assembled Condition

This is the case when the product is delivered from our factory under a condition that it is assembled with other actuators. The combined axes are delivered in a package that the frame is nailed on the lumber base. Fix the rod so that would not accidentally move during transportation. The actuators are also fixed so the tip of it would not shake due to the external vibration.

### (1) Handling the Packed Unit

- Do not hit or drop the package. No special treatment is conducted on this package to endure a drop or impact on it.
- Do not attempt to carry a heavy package with only one worker. Also, have an appropriate method for transportation.
- When hanging up with ropes, support on the reinforcement frame on the bottom of the lumber base. When bringing up the package with a forklift, also support on the bottom of the lumber base.
- Handle with care when putting the package down to avoid impact or bounce.
- Do not step on the package.
- Do not put any load that may cause a deformation or breakage of the package.

### (2) How to Handle after Unpackaged

- Secure the rods to prevent sudden movement during transport.
- If the tip of an actuator is overhanging, have an appropriate way to fix it to avoid shake due to the external vibration. In the transportation without the tip being fixed, do not apply any impact with 0.3G or more.
- When hanging up with ropes, have appropriate cushioning to avoid any deformation of the actuator body. Also keep it in stable horizontal orientation. Make a fixture utilizing the attachment holes and the tapped holes on the actuator body if necessary.
- Do not attempt to apply load on the actuators or the connector box. Also pay attention not to pinch cables and bend or deform them forcefully.

## [3] Handling in Condition of being assembled in Machinery Equipment (System)

These are some caution notes for when transporting the actuator being assembled in the machinery equipment (system):

- Secure the rods to prevent sudden movement during transport.
- If the tip of an actuator is overhanging, have an appropriate way to fix it to avoid shake due to the external vibration. In the transportation without the tip being fixed, do not apply any impact with 0.3G or more.
- When hanging up the machinery equipment (system) with ropes, do not attempt to apply load on the actuators or the connector box. Also pay attention not to pinch cables and bend or deform them forcefully.

## 2.2 Installation and Storage • Preservation Environment

### [1] Installation Environment

The actuator should be installed in a location other than those specified below.

In general, the installation environment should be one in which an operator can work without protective gear.

Also provide sufficient work space required for maintenance inspection.

- Where the actuator receives radiant heat from strong heat sources such as heat treatment furnaces
- Where the ambient temperature exceeds the range of 0 to 40°C
- Where the temperature changes rapidly and condensation occurs
- Where the relative humidity exceeds 85% RH
- Where the actuator receives direct sunlight
- Where the actuator is exposed to corrosive or combustible gases
- Where the ambient air contains a large amount of powder dust, salt or iron (at level exceeding what is normally expected in an assembly plant)
- Where the actuator is subject to splashed water, oil (including oil mist or cutting fluid) or chemical solutions
- Where the actuator receives impact or vibration
- Where the altitude is more than 2000m

If the actuator is used in any of the following locations, provide sufficient shielding measures:

- Where noise generates due to static electricity, etc.
- Where the actuator is subject to a strong electric or magnetic field
- Where the actuator is subject to ultraviolet ray or radiation

### [2] Storage • Preservation Environment

- The storage and preservation environment should comply with the same standards as those for the installation environment. In particular, when the machine is to be stored for a long time, pay close attention to environmental conditions so that no dew condensation forms.
- Unless specially specified, moisture absorbency protection is not included in the package when the machine is delivered. In the case that the machine is to be stored and preserved in an environment where dew condensation is anticipated, take the condensation preventive measures from outside of the entire package, or directly after opening the package.
- For storage and preservation temperature, the machine withstands temperatures up to 60°C for a short time, but in the case of the storage and preservation period of 1 month or more, control the temperature to 50°C or less.
- Storage and preservation should be performed in the horizontal condition. In the case it is stored in the packaged condition, follow the posture instruction if any displayed on the package.

## 2.3 How to Install

This chapter explains how to install the actuator on your mechanical system.



### 2.3.1 Installation

Follow the information below when installing the actuator, as a rule.  
Do pay attention to these items (except with custom-order models).

○ : Possible    △ : Daily inspection is required    × : Not possible

Model	Horizontal installation	Vertical installation	Sideway installation	Ceiling mount installation
RA4C, RA4R RA6C, RA6R RA7C, RA7R RA8C, RA8R	○	○	○	○

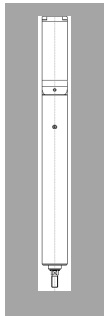
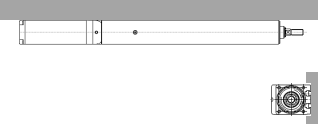
#### Installation Orientation

Horizontal	Vertical	Sideways	Ceiling mount
			

 **Note:**

- Grease has been applied to the outer periphery of the rod. Protect the peripheral equipments if they are affected by grease adhesion.
- When the unit is installed vertically oriented, Motor straight type is attempt to put the motor up unless there is a special reason. · Putting the motor on the lower side would not cause a problem in an ordinary operation. However, it may rarely cause a problem, when it is not operated for a long period, depending on the surrounding environment (especially high temperature), caused by the grease being separated and the base oil flowing into the motor unit.

## 2.3.2 Installation of the Main Unit

The surface to mount the main unit should be a machined surface or a plane that possesses an equivalent accuracy and the flatness should be within 0.05mm/m. Also, the platform should have a structure stiff enough to install the unit so it would not generate vibration or other abnormality.

Also consider enough space necessary for maintenance work such as actuator replacement and inspection.

T-slots are provided on the back of the actuator.

Nut holes are provided on the actuator frame front and the side-mounted motor type rear bracket.

Using these parts, the following installations can be realized.

- Installation by using T-slots
- Installation by using foot brackets (option: model FT)
- Installing main unit frame front
- Installation by using flange (option: model FL)
- Installation by using rear bracket for side-mounted motor types

### [1] Using the T-slot on the Bottom of the Base

This actuator has T-slot for mounting so it can be fixed from the bottom of the base.

There are two methods of installation: using square T-nuts into T-slots or using optional T-slot nut bars (model: NTB).

#### (1) T-slots Dimensions

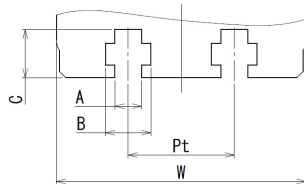

	RA4	RA6	RA7	RA8
W[mm]	40	58	70	85
Pt[mm]	17	25	35	40
A[mm]	4.3	6.3	6.3	8.5
B[mm]	7.3	10.3	10.3	13.3
C[mm]	7.7	9	10.5	14

## (2) Installation by Square Nuts

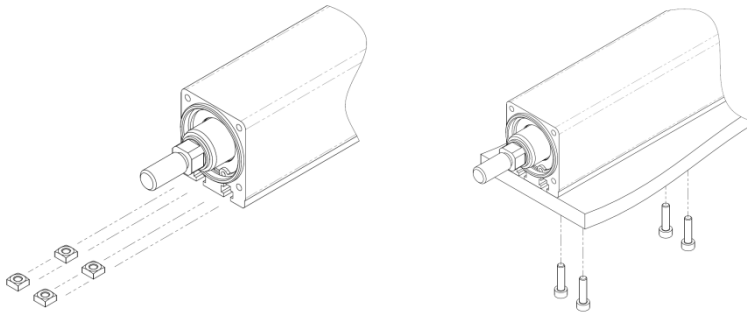

Square nuts prescribed in JISB1163 can be used for the T-slots.  
Quantities of the square nuts enclosed at the time of shipment are as follows.

	RA4	RA6	RA7	RA8
Quantities Enclosed	4	4	8	8
Attachment Bolts	M4	M6	M6	M8

(Note) When optional T-slot nut bars (model: NTB) are selected, the square nuts are not enclosed.

Adjust the screw length from the base bottom according to the following table to ensure the fitting length of the nut and the screw.

	RA4	RA6	RA7	RA8
Screw Length [mm] From the Base Bottom	5 to 7	7.5 to 8.5	8 to 10	11 to 13

Install them according to the minimum fixing number of bolts and the tightening torque in the following table.

	RA4	RA6	RA7	RA8
Minimum Fixing Number (Bolts)	4	4	6	8
Tightening Torque[Nm]	1.76	5.36	5.36	11.48

**⚠ Caution:** Be careful when selecting the bolt length. If bolts of inappropriate lengths are used, the tapped holes may be damaged, actuator mounting strength may become insufficient, or contact with driving parts may occur, resulting in lower precision or unexpected accidents.

### (3) Installation by T-Slot Nut Bar (Option Model: NTB)

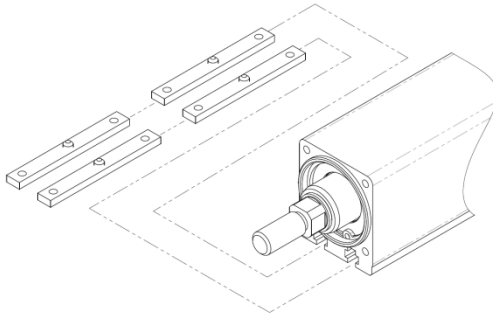

Four T-slot nut bars (option model: NTB) are shipped in a built-in-state in all sizes. Before you use them, loosen the hexagonal socket head fixing screws in the center of the nuts to move them to the desired positions. Do not overly tighten the hexagonal socket head fixing screws, for they are used only for positioning. Use the nut bars in a pitch as wide as possible to stabilize the mounting.

Adjust the screw length from the base bottom according to the following table to ensure the fitting length of the nut and the screw.

	RA4	RA6	RA7	RA8
Screw Length [mm] From the Base Bottom	5 to 7	7.5 to 8.5	8 to 10	11 to 13

Install them according to the minimum fixing number of bolts and the tightening torque in the following table.

	RA4	RA6	RA7	RA8
Minimum Fixing Number (Bolts)	4	4	6	8
Tightening Torque[Nm]	1.76	5.36	5.36	11.48

**⚠ Caution:** Be careful when selecting the bolt length. If bolts of inappropriate lengths are used, the tapped holes may be damaged, actuator mounting strength may become insufficient, or contact with driving parts may occur, resulting in lower precision or unexpected accidents.



The attachable positions of T-Slot nut bars (model: NTB) are as follows.

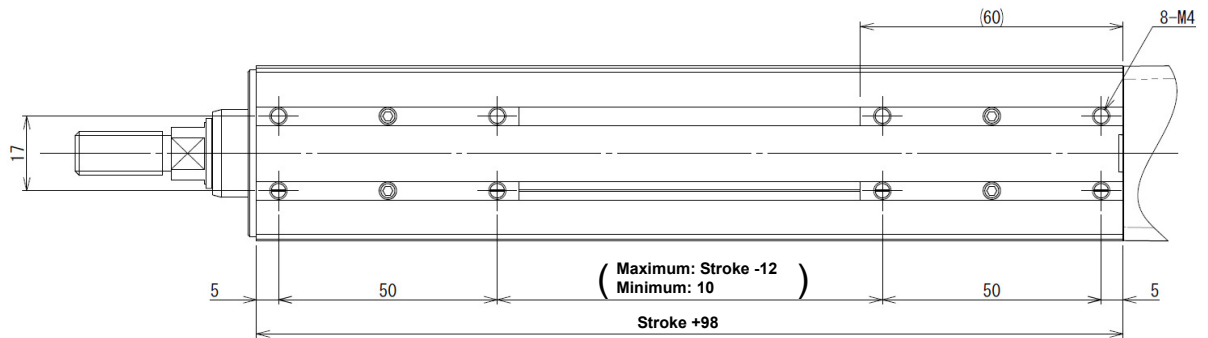

RA4

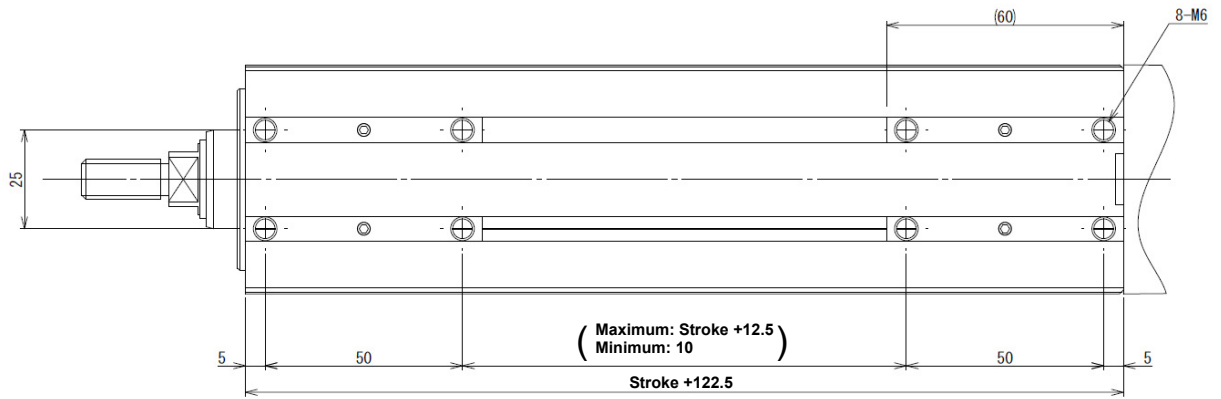

RA6

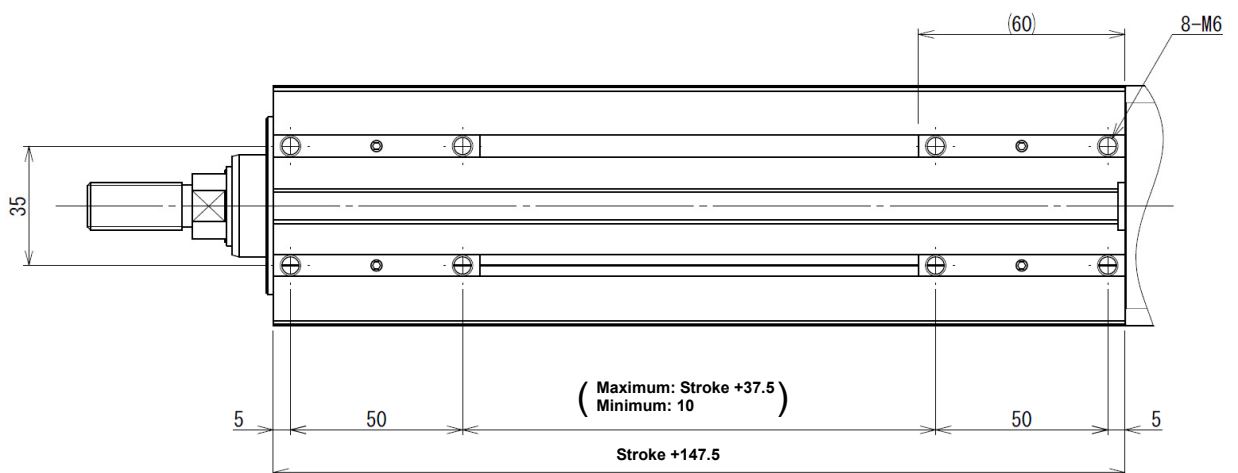

RA7

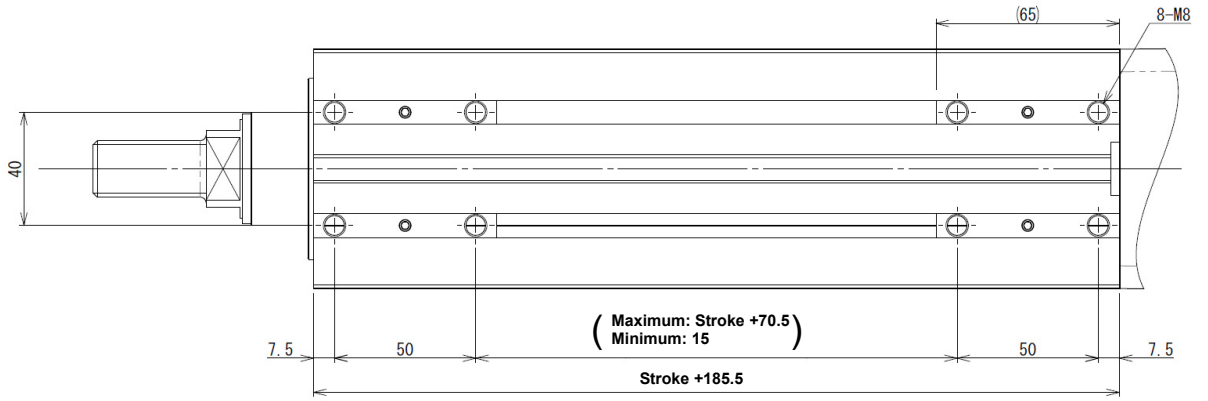

2. Installation

RA8

## [2] When Utilizing Foot Brackets for Installation

Actuators can be installed by using the foot brackets (option: model FT).

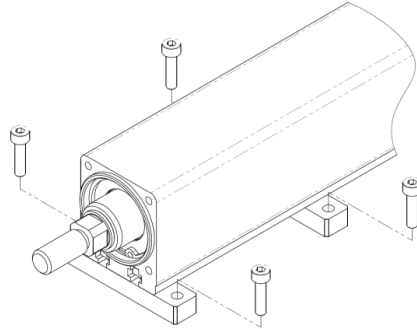

Foot bases are shipped in the state fixed to the both ends of the actuator frame.  
Before use, loosen the bolts fixing the foot bases and move them to the desired positions.

[Width direction pitch of foot bracket, attachment bolts and others]  
Straight Type, Motor Top Side-Mounted Type (Model: MT)

	RA4	RA6	RA7	RA8
Width Direction Hole Pitch [mm]	50	72	85	100
Thickness [mm]	8	10	12	16
Material	Steel	Steel	Steel	Steel
Attachment Bolts	M4	M6	M6	M8

Motor Left Side-Mounted (Model: ML), Motor Right Side-Mounted (Model: MR) Except RCP6S-RA4R

	RA4	RA6	RA7	RA8
Width Direction Hole Pitch [mm]	100	132	160	190
Thickness [mm]	8	10	12	16
Material	Steel	Steel	Steel	Steel
Attachment Bolts	M4	M6	M6	M8

Motor Left Side-Mounted (Model: ML), Motor Right Side-Mounted (Model: MR) of RCP6S-RA4R

	RA4	RA6	RA7	RA8
Width Direction Hole Pitch [mm]	121	/	/	/
Thickness [mm]	8			
Material	Steel			
Attachment Bolts	M4			

[Tightening Torque]

Model	Screw Nominal Diameter	In the case that steel is used for the bolt seating surface:
RA4	M4	3.59N·m(0.37kgf·m)
RA6, RA7	M6	12.3N·m(1.26kgf·m)
RA8	M8	30N·m(3.1kgf·m)

The attachment positions of foot brackets (model: FT) at the shipment are as follows.

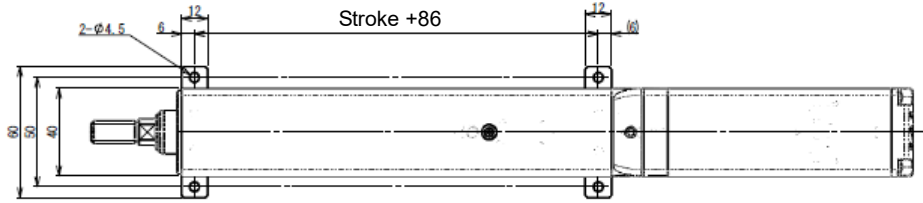

RCP6(S)-RA4C

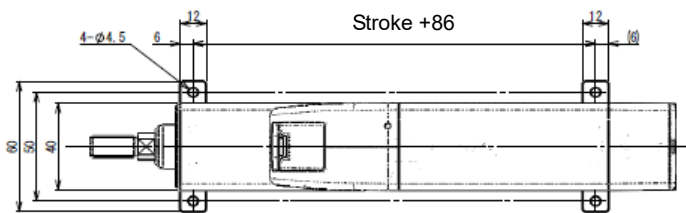

RCP6(S)-RA4R Motor Top Side-Mounted Type (Model: MT)

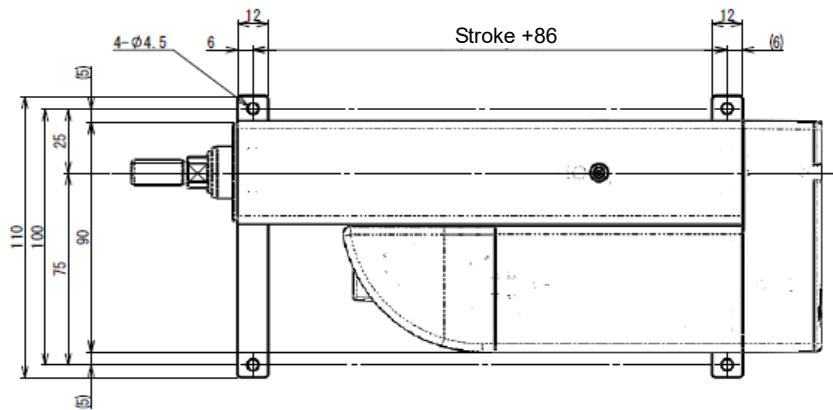

RCP6-RA4R Motor Left Side-Mounted (ML), Motor Right Side-Mounted (MR)

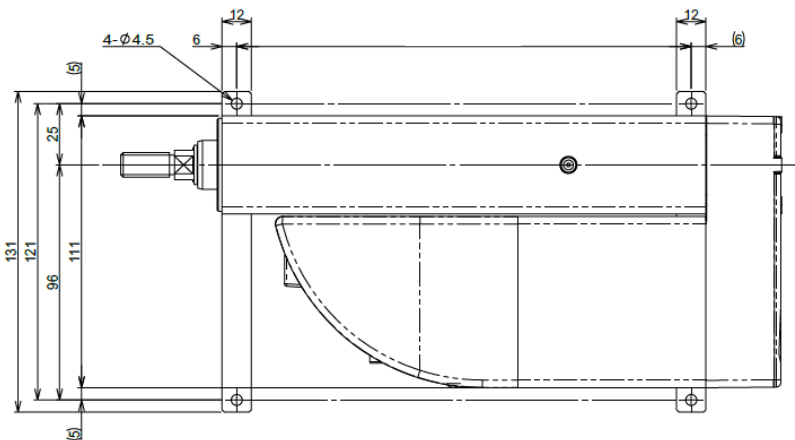

RCP6S-RA4R Motor Left Side-Mounted (ML), Motor Right Side-Mounted (MR)

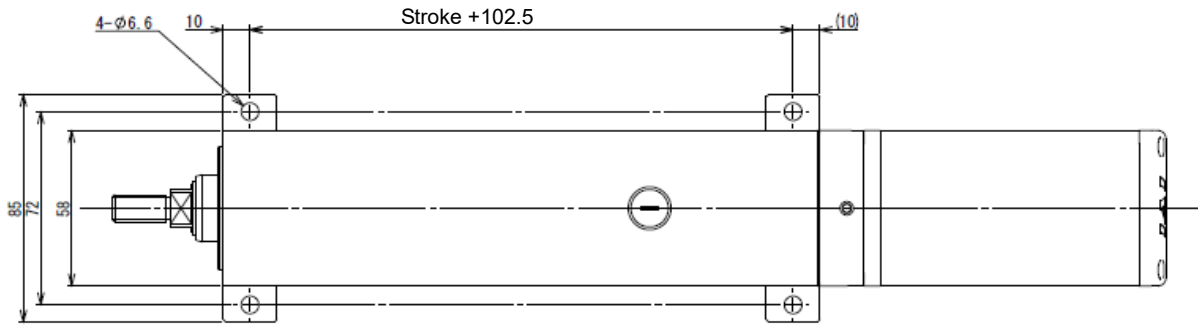

RCP6(S)-RA6C

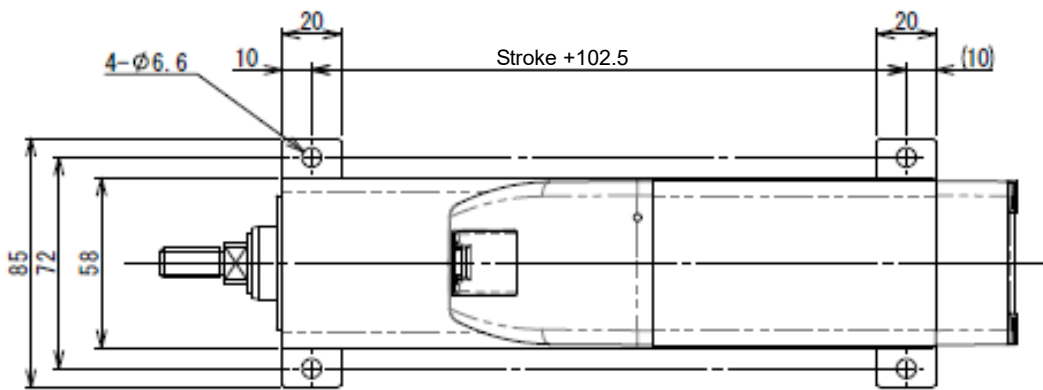

RCP6(S)-RA6R Motor Top Side-Mounted Type (Model: MT)

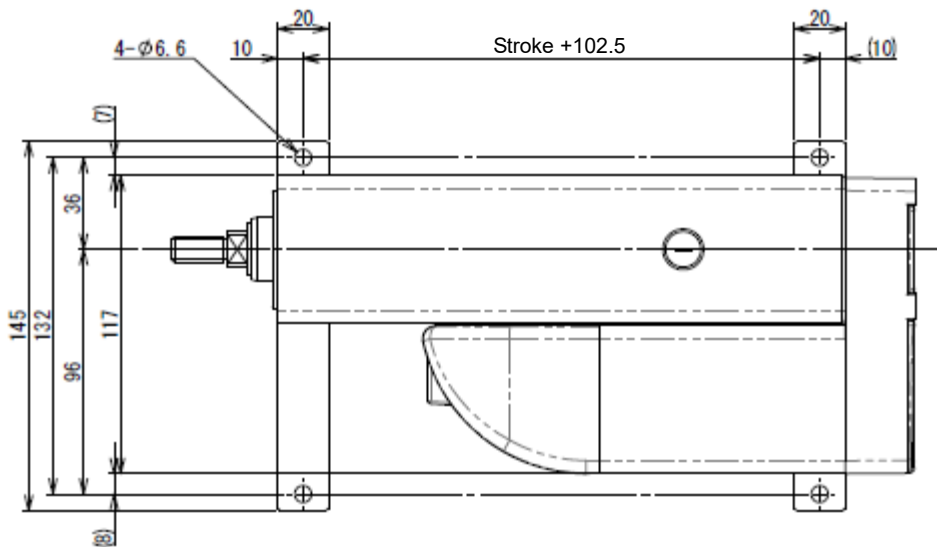

RCP6(S)-RA6R Motor Left Side-Mounted (ML), Motor Right Side-Mounted (MR)

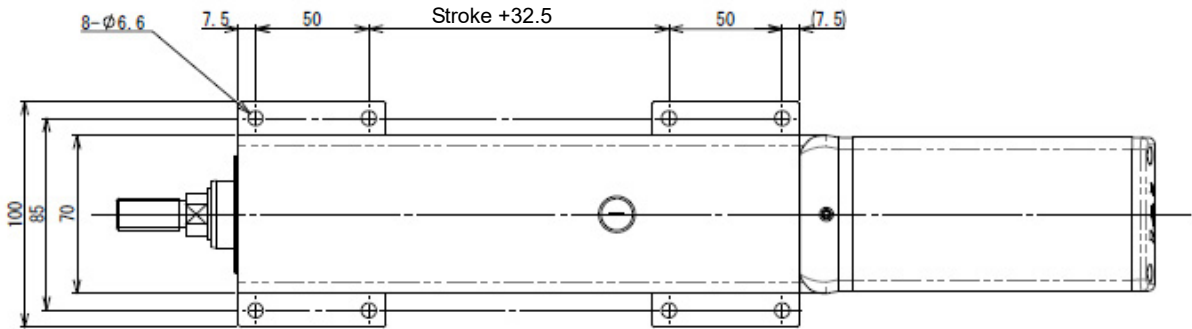

RCP6(S)-RA7C

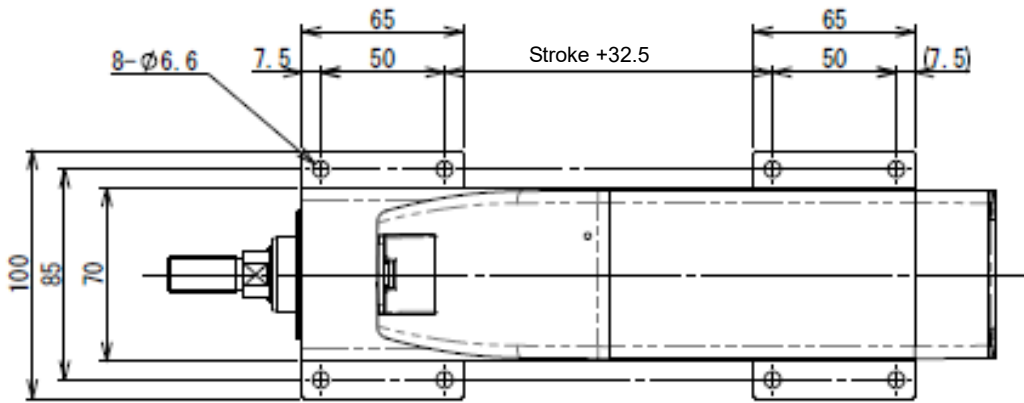

RCP6(S)-RA7R-MT Motor Top Side-Mounted Type (Model: MT)

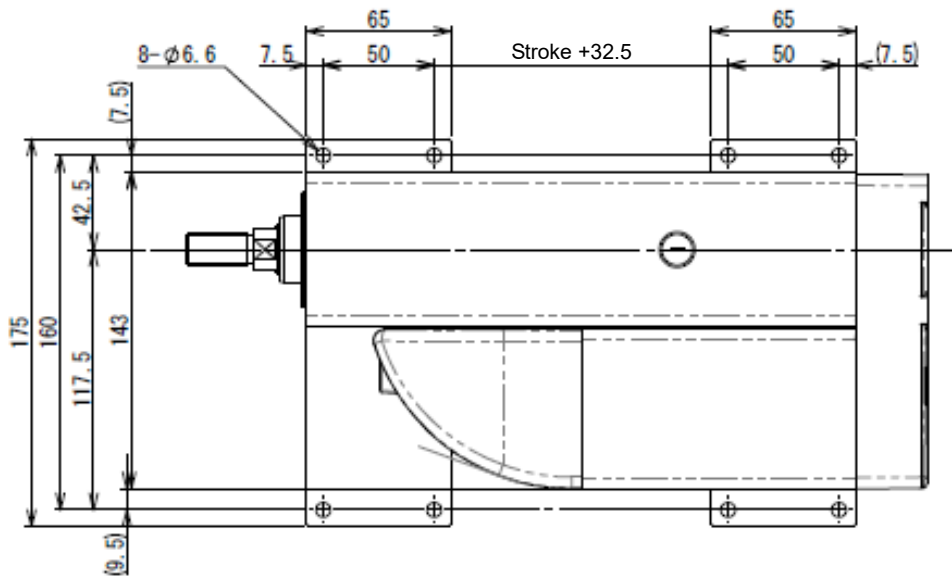

RCP6(S)-RA7R Motor Left Side-Mounted (ML), Motor Right Side-Mounted (MR)

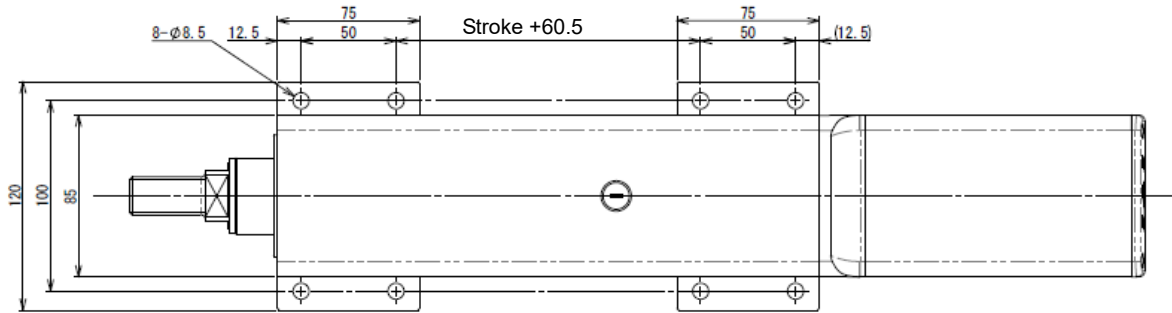

RCP6(S)-RA8C

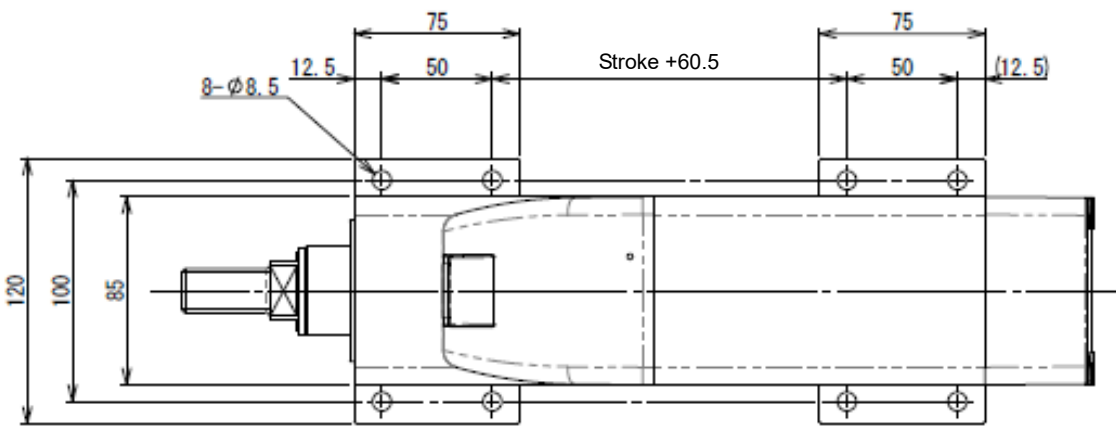

RCP6(S)-RA8R Motor Top Side-Mounted Type (Model: MT)

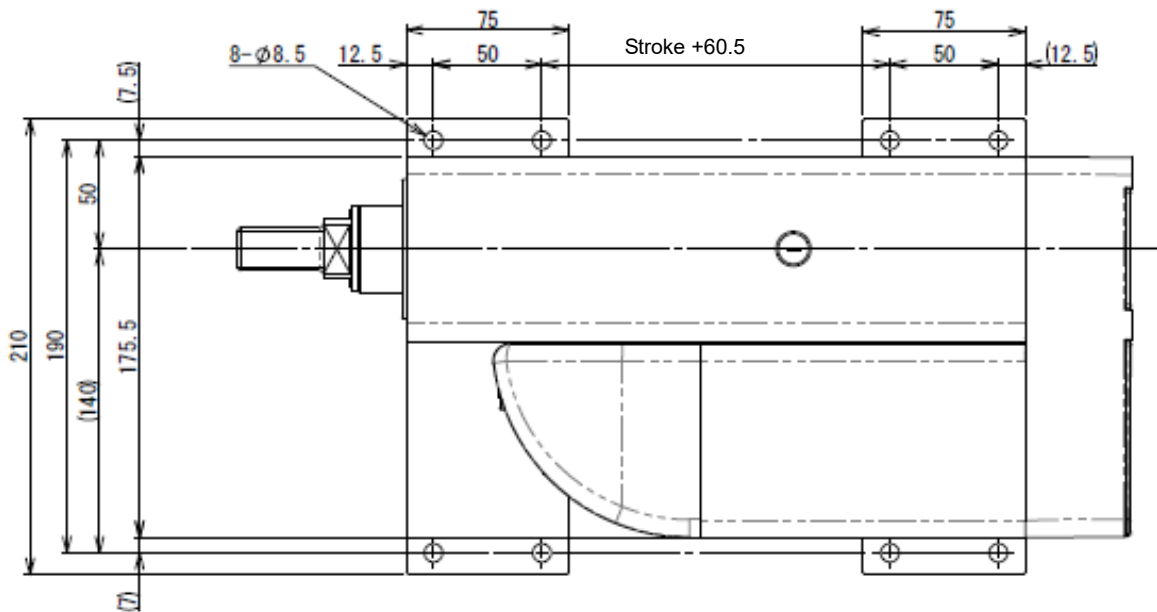

RCP6(S)-RA8R Motor Left Side-Mounted (ML), Motor Right Side-Mounted (MR)

## Tightening Screws

- Use hexagonal socket head bolts for the male threads for installing the base.
- Use of high-tension bolts meeting at least ISO 10.9 is recommended.
- For the effective engagement length between the bolt and female thread, provide at least the applicable value specified below:  
Female thread is made of steel material → Same length as the nominal diameter  
Female thread is made of aluminum → 1.8 times of nominal diameter

 **Caution:** Be careful when selecting the bolt length. If bolts of inappropriate lengths are used, actuator mounting strength may become insufficient, or contact with driving parts may occur, resulting in lower precision or unexpected accidents.



### [3] When using Tapped Holes on Front Bracket

There are tapped holes equipped on the front bracket.  
Utilize these tapped holes for installation.  
The effective depth for the attachment screws is as shown below;

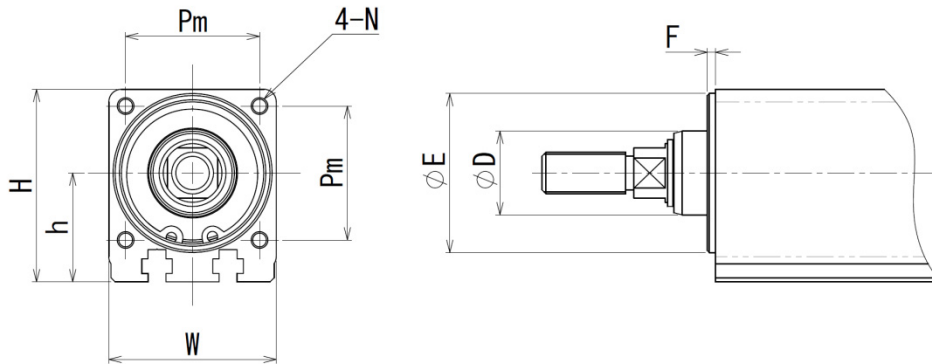

	RA4	RA6	RA7	RA8
W[mm]	40	58	70	85
h[mm]	26	32	38	50
H[mm]	46	61	73	92.5
Pm[mm]	32	45	55	70
N	M4 Depth 8	M6 Depth 12	M8 Depth 16	M8 Depth 16
D[mm]	ø20	ø25	ø30	ø40
E[mm]	ø38h7	ø46h7	ø52h7	ø64h7
F[mm]	2	2	2	2

#### [Tightening Torque]

Model	Screw Nominal Diameter	In the case that steel is used for the bolt seating surface:	In the case that aluminum is used for the bolt seating surface:
RA4	M4	3.59N·m(0.37kgf·m)	1.76N·m(0.18kgf·m)
RA6	M6	12.3N·m(1.26kgf·m)	5.4N·m(0.55kgf·m)
RA7, RA8	M8	30N·m(3.1kgf·m)	11.5N·m(1.2kgf·m)

Make sure to follow “© Caution for Installation using Front Bracket and Front Flange”

#### Tightening screws

- Use hexagonal socket head bolts for the male threads for installing the base.
- Use of high-tension bolts meeting at least ISO 10.9 is recommended.
- Have the length of thread engagement approximately 1.8 times of the nominal diameter.

 **Caution:** Be careful when selecting the bolt length. If bolts of inappropriate lengths are used, the tapped holes may be damaged, actuator mounting strength may become insufficient, or contact with driving parts may occur, resulting in lower precision or unexpected accidents.

## ⊙ Caution for Installation using Front Bracket

Do not attempt to apply any external force to the body when installing with front bracket. External force may cause an operation failure or parts malfunction.

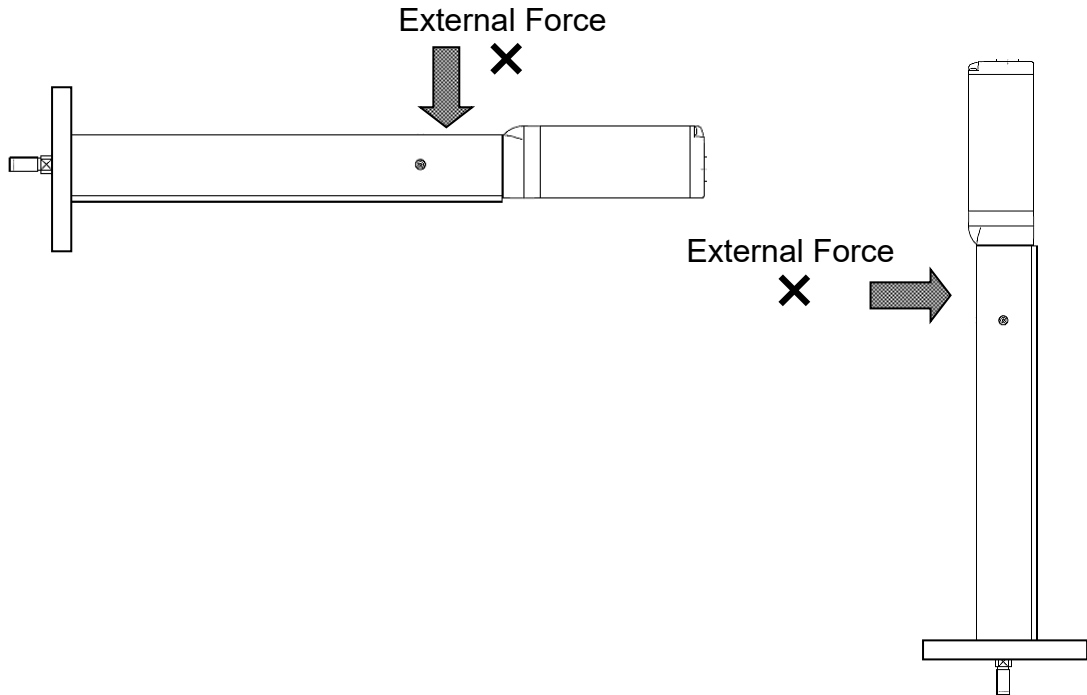

Prepare a support block as shown in the figure below for the horizontal installation of the unit with its stroke more than 150 even if there is no external force applied on the body. Even for those with the stroke less than 150, it is recommended to have a support block to avoid vibration being generated due to the operation condition or installation environment, which may cause an operation failure or parts malfunction.

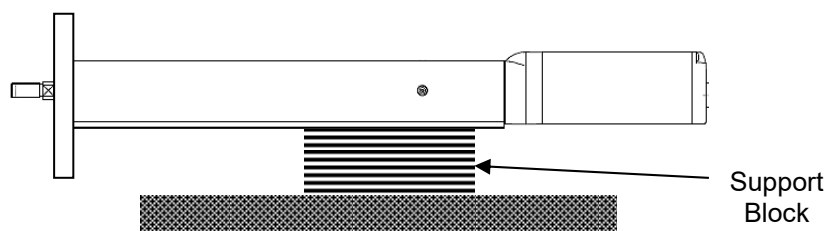

[4] When using Front Flange (Option)

There are tapped holes equipped on the front housing (Option).  
Utilize these tapped holes for installation.

[Refer to 9. “External Dimensions” for the dimensions after attaching the front flange.]

Although this option is ordered along with an actuator, they will be shipped as accessories (not assembled parts). Attach the flange to the actuator using the enclosed bolts with prescribed torque.

(Note) The front flange cannot be installed in the vertical direction (height direction) because the Motor Top Side-Mounted Types (Model: MT) of side-mounted motor types RA4R, RA6R, RA7R, and RA8R with the following strokes will interfere with the motor unit.

(Note) The front flange cannot be installed in the horizontal direction (width direction) because Motor Left Side-Mounted (ML) and Motor Right Side-Mounted (MR) of side-mounted motor types RA4R, RA6R, RA7R, and RA8R with the following strokes will interfere with the motor unit.

Model Name	Stroke
RCP6-RA4R	50、100、150
RCP6S-RA4R	50、100、150
RCP6-RA6R	50、100
RCP6S-RA6R	50、100、150、200
RCP6-RA7R	50、100、150
RCP6S-RA7R	50、100、150、200
RCP6-RA8R	50、100
RCP6S-RA8R	50、100、150

(Note) Be cautious that the end cover may be projected from the entire actuator frame in the case of reserving types.

Flatness of the mounting surface should be less than 0.050mm.  
The dimensions of the front flange are as follows.

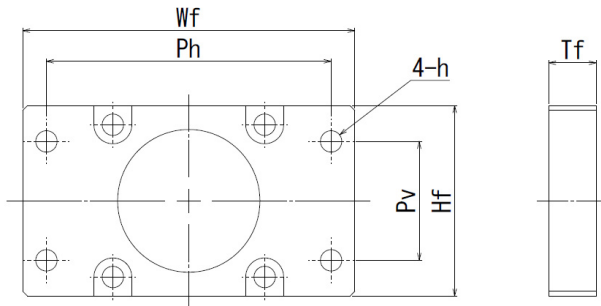

	RA4	RA6	RA7	RA8
Wf[mm]	70	90	108	135
Hf[mm]	40	56	68	84
Ph[mm]	60	75	90	115
Pv[mm]	25	40	50	65
h[mm]	4.5	6.6	8.5	8.5
Tf[mm]	10	12	16	19
Material	Steel	Steel	Steel	Steel
Enclosed Bolts	M4x12	M6x15	M8x20	M8x25
Tightening Torque of the Front Flange to the Main Unit [N·m]	2.1	4.2	7.1	17.2

[Tightening Torque]

Model	Screw Nominal Diameter	In the case that steel is used for the bolt seating surface:
RA4	M4	3.59N·m(0.37kgf·m)
RA6	M6	12.3N·m(1.26kgf·m)
RA7, RA8	M8	30N·m(3.1kgf·m)

Make sure to follow “© Caution for Installation using Front Bracket and Front Flange”

Tightening screws

- Use hexagonal socket head bolts for the male threads for installing the base.
- Use of high-tension bolts meeting at least ISO 10.9 is recommended.
- For the effective engagement length between the bolt and female thread, provide at least the applicable value specified below:  
 Female thread is made of steel material → Same length as the nominal diameter  
 Female thread is made of aluminum → 1.8 times of nominal diameter

⚠ Caution: Be careful when selecting the bolt length. If bolts of inappropriate lengths are used, actuator mounting strength may become insufficient, or contact with driving parts may occur, resulting in lower precision or unexpected accidents.

## ⊙ Caution for Installation using Front Bracket and Front Flange

Do not attempt to apply any external force to the body when installing with front bracket or front flange (option). External force may cause an operation failure or parts malfunction

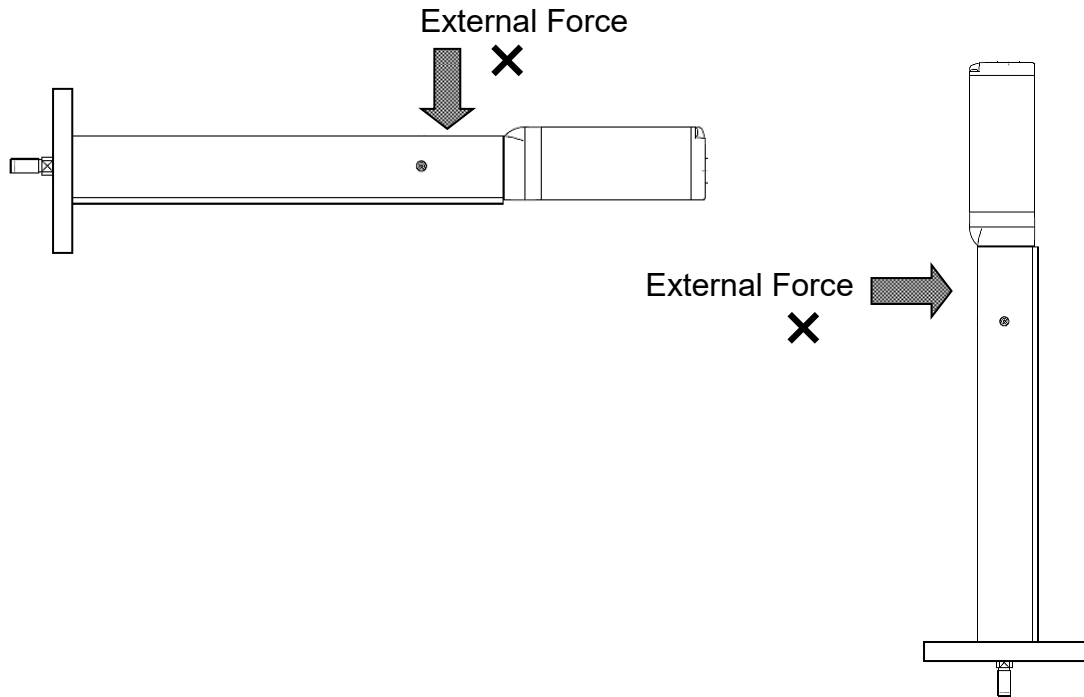

Prepare a support block as shown in the figure below for the horizontal installation of the unit with its stroke more than 150 even if there is no external force applied on the body. Even for those with the stroke less than 150, it is recommended to have a support block to avoid vibration being generated due to the operation condition or installation environment, which may cause an operation failure or parts malfunction.

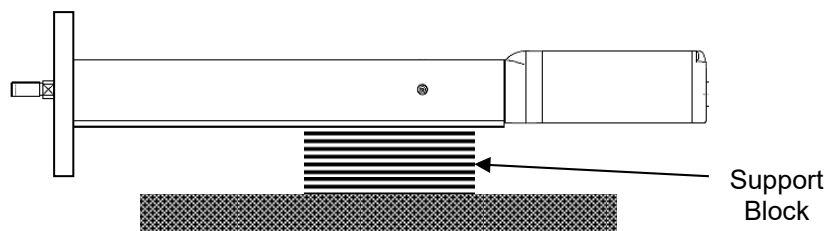

[5] When Utilizing Attachment Holes on the Rear Bracket for Side-Mounted Motor Type

For RA4R, RA6R, RA7R and RA8R, there are tapped holes prepared on the side-mounted bracket. (See the table below for the detailed dimensions.)

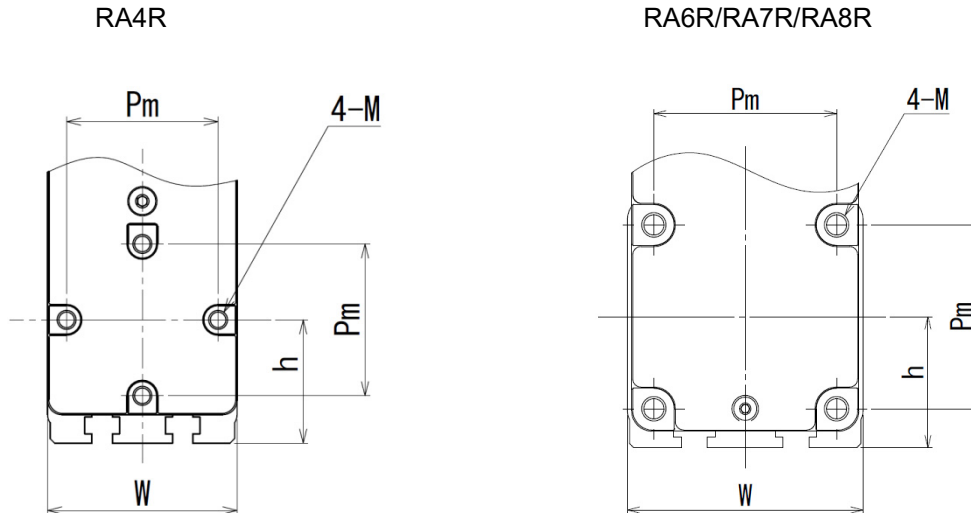

	RA4	RA6	RA7	RA8
W[mm]	40	58	70	85
h[mm]	26	32	38	50
Pm[mm]	32	45	55	70
M	M4 Depth 8	M6 Depth 12	M8 Depth 16	M8 Depth 16

[Tightening Torque]

Model	Screw Nominal Diameter	In the case that steel is used for the bolt seating surface:	In the case that aluminum is used for the bolt seating surface:
RA4	M4	3.59N·m(0.37kgf·m)	1.76N·m(0.18kgf·m)
RA6	M6	12.3N·m(1.26kgf·m)	5.4N·m(0.55kgf·m)
RA7, RA8	M8	30N·m(3.1kgf·m)	11.5N·m(1.2kgf·m)

Tightening Screws

- Use hexagonal socket head bolts for the male threads for installing the base.
- Use of high-tension bolts meeting at least ISO 10.9 is recommended.
- Have the length of thread engagement approximately 1.8 times of the nominal diameter.

 **Caution:** Be careful when selecting the bolt length. If bolts of inappropriate lengths are used, the damage of the attachment hole and actuator mounting strength may become insufficient, or contact with driving parts may occur, resulting in lower precision or unexpected accidents.

[Precautions for Attachments]

Please note the following caution notes when installing the unit with using the tapped holes on the side-mounted bracket.

Do not attempt to affix the unit only with the tapped holes on the side-mounted bracket.

Do not apply external force to the main body.

There may be caused vibration due to the operating condition or installation environment, which may result in operational failures or components malfunction.

⊙ Caution for Installation using Rear Bracket

Do not try to install rear bracket without any support. Always use a support block or similar to support the main unit.

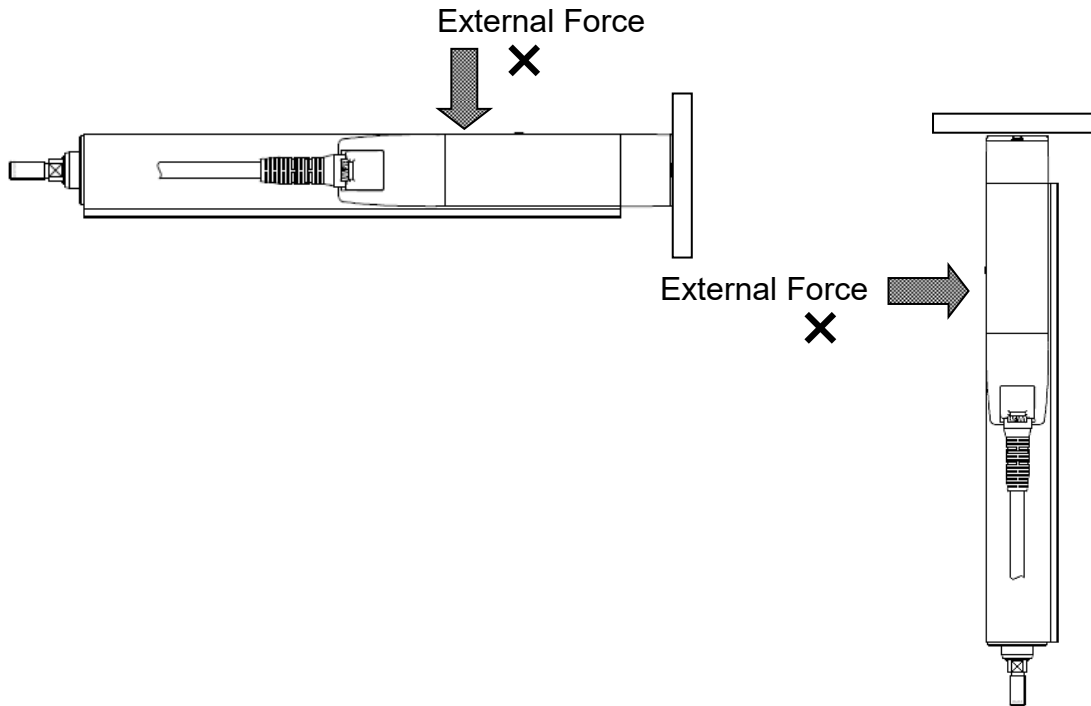

When it is perpendicular installation without support etc., external force does not act, it is not attempt to apply the radial load.

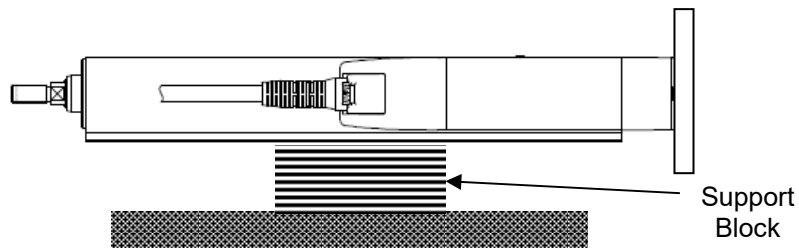

### 3. Connecting with the Controller

As the connection cable for the controller and RCP6/RCP6S (this actuator), use the IAI-dedicated controller and dedicated connection cable.

This section explains the wiring method for a single axis.

- If the dedicated connection cable cannot be secured, reduce the load on the cable by allowing it to deflect only by the weight of the cable or wire it in a self-standing cable hose, etc., having a large radius.
- Do not cut and reconnect the dedicated connection cable for extension or shorten the cable.
- Do not pull on the dedicated connection cable or bend it forcibly.
- The actuator cable coming out of the motor unit is not meant to be bent. Fix the cable so it would not be bent repeatedly

Please consult with IAI if you require a different kind of cable than the one supplied.

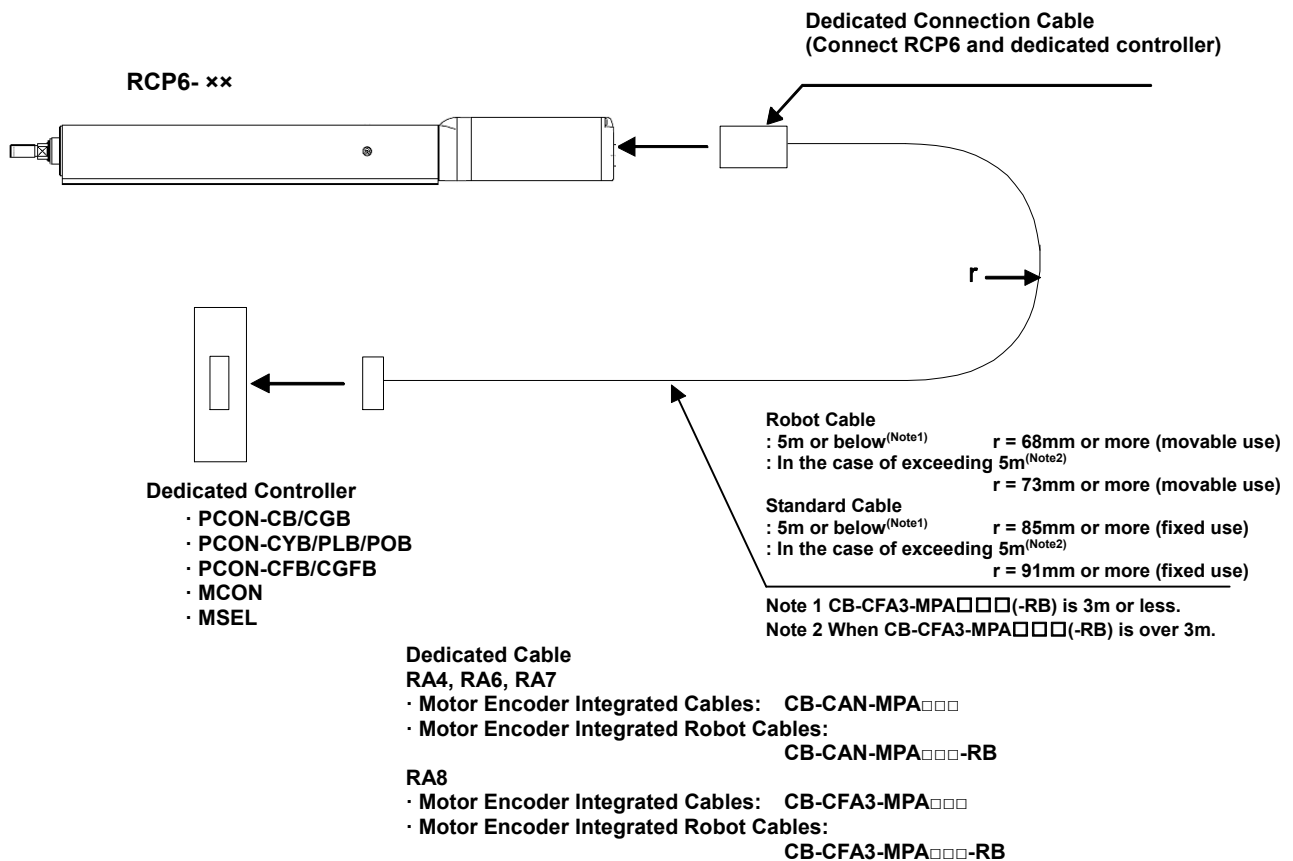

\* □□□ represents the cable length. The longest corresponds to 20m.  
e.g.) 080 = 8m



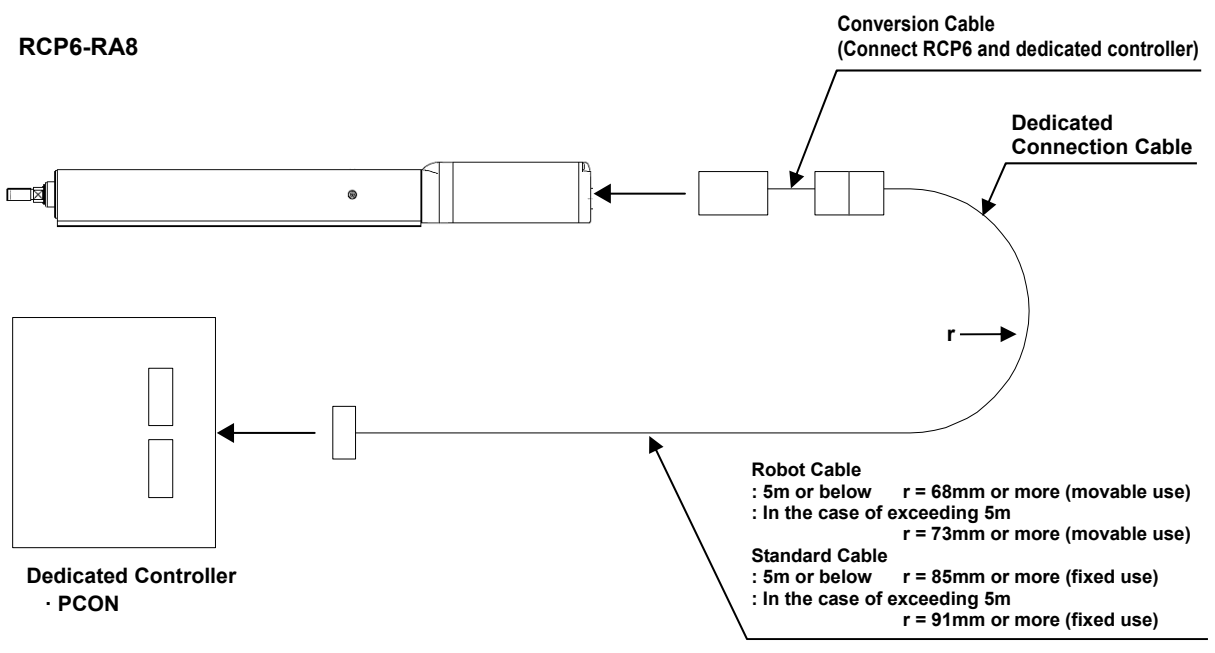
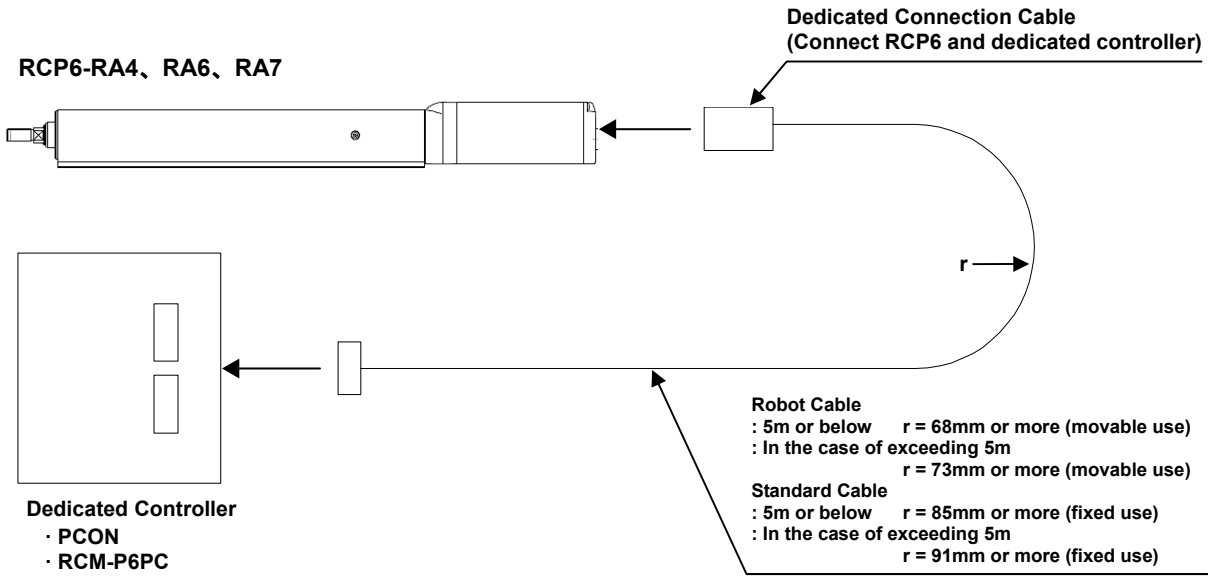

**Dedicated Cable**  
· Motor Encoder Integrated Cables: CB-ADPC-MPA□□□  
· Motor Encoder Integrated Robot Cables: CB-ADPC-MPA□□□-RB

\* □□□ represents the cable length. The longest corresponds to 20m.  
e.g.) 080 = 8m

For RA8, connect to the actuator additionally using a conversion cable CB-CAN-AJ0002.



- Do not attempt to use the motor / encoder cable in a condition that the cable is bundled up in several layers such as coil winding.  
There are motor driving power line and encoder signal line in the motor / encoder cable. Therefore, if the motor / encoder cable is bundled up, the noise generated from the motor driving power line could give an influence to the encoder and may cause an error.



- Have a sufficient radius for bending, and avoid a bend concentrating on one point.

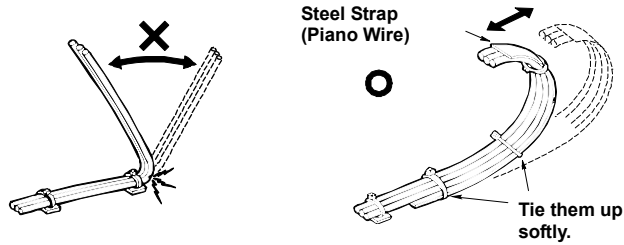

- Do not let the cable bend, kink or twist.

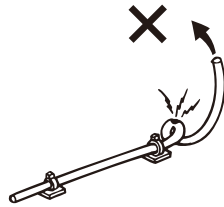

- Do not pull the cable with a strong force.

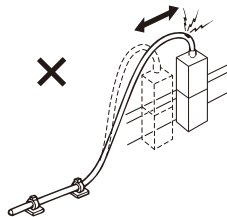

- Pay attention not to concentrate the twisting force to one point on a cable.

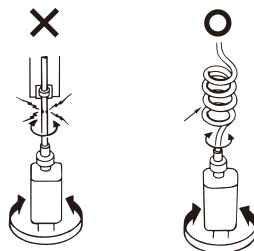

- Do not pinch, drop a heavy object onto or cut the cable.

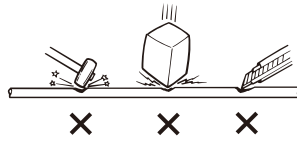

- When a cable is fastened to affix, make sure to have an appropriate force and do not tighten too much.

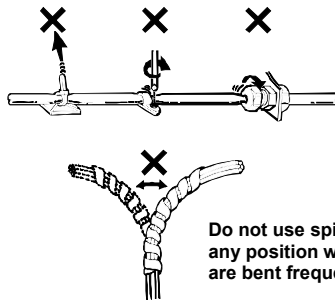

- PIO line, communication line, power and driving lines are to be put separately from each other and do not tie them together. Arrange so that such lines are independently routed in the duct.

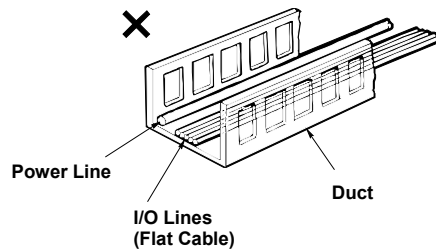

Follow the instructions below when using a cable track.

- If there is an indication to the cable for the space factor in a cable track, refer to the wiring instruction given by the supplier when storing the cable in the cable track.
- Avoid the cables to get twined or twisted in the cable track, and also to have the cables move freely and do not tie them up. (Avoid tension being applied when the cables are bent.) Do not pile up cables. It may cause faster abrasion of the sheaths or cable breakage.

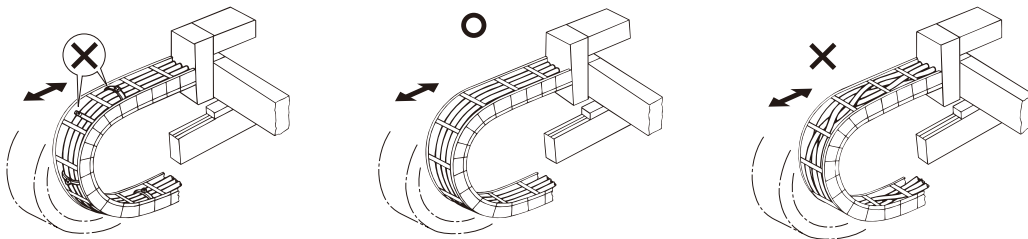

## 4. Caution for Operation

- When you tighten the nut onto the tip bracket threaded part, hold a wrench to width across flat part of the tip bracket with the rod in the most retracted state. Also, avoid that the load is applied to the inside whirl-stop as you tighten the nut.  
As a general rule, it cannot be used to apply a torque to the rod tip. Statically acceptable values and the rod tip maximum displacement angles (initial value reference) expected at that time are shown below. When the reaction force against the pressing operation is the side-way force, make sure it would not exceed the allowable load.

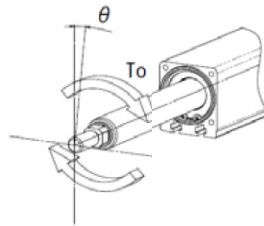

	RA4	RA6	RA7	RA8
$T_o$ [Nm]	1.0	1.5	2.5	5.0
$\theta$ [deg]	$\pm 1.0$	$\pm 1.0$	$\pm 0.8$	$\pm 0.8$

- Do not apply radial load and load moment to the rod. Only the radial direction load that aligns with the rod axis can be applied.  
In the case that radial load and load moment cannot be avoided, attach an external guide (such as a linear guide) in order not to apply any load other than radial direction load to the rod.  
When the gravity center of work is on the rod axis on vertical motions, vibration may still be generated by the clearance of internal whirl-stop. Attachment of an external guide is recommended to suppress such vibration.
- When connecting the rod to external guides, be careful on the parallelism of the guides to the rod. When connecting and fixing the rod to external guides, be careful not to apply excess side-way load to the rod because of the assembly variation.

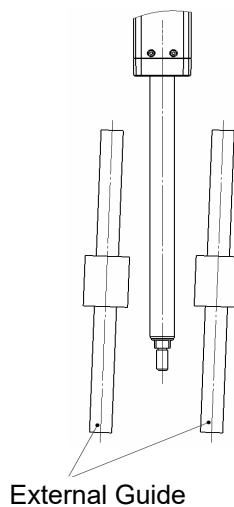

## 5. Maintenance and Inspection

### 5.1 Inspection Items and Schedule

Follow the maintenance inspection schedule below.

It is assumed that the equipment is operating 8 hours per day.

If the equipment is running continuously night and day or otherwise running at a high operating rate, inspect more often as needed.

	External visual inspection	Greasing
Start of work inspection	○	
1 month inspection	○	
3 month inspection	○	○(Rod sliding surface, Ball screw, Whirl-stop)
Every 3 months thereafter	○	○ (Rod sliding surface)
6 month inspection	○	○(Ball screw, Whirl-stop)
Every 6 months thereafter	○	○(Ball screw, Whirl-stop)

- \*1 Grease the rod sliding surface when grease is insufficient at start of work inspection, or every three month. When greasing, always wipe off old grease before supplying new one. The base oil may be separated from grease, depending on the installation orientation and operating conditions. Perform visual inspection for any occurrence of drip.

 **Caution:**

- An actuator after 6 months of storage may have caused a degradation of the grease.  
Supply grease before start using. [Refer to 5.6 “Grease Supply”]
- Degradation speed of grease may differ depending on the environment of use (temperature, humidity and ambient conditions). It is recommended to shorten the grease supply period if the actuator is used under a bad condition such as in high temperature, high humidity or in dusty ambience.  
Also, it is recommended to improve the environment conditions in case the grease changes its color due to the bad condition of use.

## 5.2 External Visual Inspection

An external visual inspection should check the following things.

Main unit	Loose actuator mounting bolts, other loose items
Rod sliding surface	Lubrication state of grease Drip of grease base oil or other oils Adhesion of dust and other foreign objects
Cables	Scratches, proper connections
Overall	Irregular noise, vibration

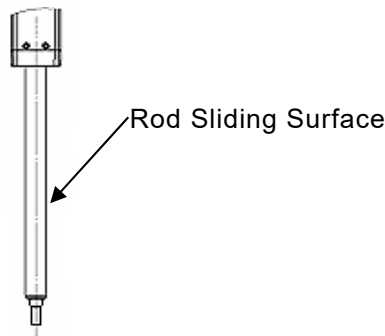

## 5.3 Cleaning

- Clean exterior surfaces as necessary.
- If there are drips of grease base oil or other oils on the rod sliding surface and the surrounding area, wipe off with with a soft cloth.
- Use a soft cloth to wipe away dirt and buildup.
- Do not blow too hard with compressed air as it may cause dust to get in through the gaps.
- Do not use oil-based solvents as they can harm lacquered and painted surfaces.
- To remove severe buildup, wipe gently with a soft cloth soaked in a neutral detergent or alcohol.

## 5.4 Grease Supply

### 5.4.1 What Grease to Use

IAI uses the following grease in our plant.

Ball screw	Kyodo Yushi	Multitemp LRL No.3
Whirl-stop	Kyodo Yushi	Multitemp LRL No.3
Rod (sliding surface)	Kyodo Yushi	Multitemp LRL No.3

Use lithium-based spray grease for maintenance.

Wako Chemical	Spray grease No.A161 or equivalents
---------------	-------------------------------------

**⚠ Warning:** Never use anything other than synthetic poly-olefin grease. Mixing poly-grease with other grease not only reduces the performance of the grease, it may even cause damage to the actuator.

## 5.4.2 How to Apply Grease

- (1) There are three greasing ports. (One port may be concealed in the case of the side-mounted motor type.) Choose one of the greasing ports for greasing.  
For RA4, remove the slim hexagonal socket head bolts (M3 x 4) blocking one of the greasing ports with an Allen wrench.  
For RA6/RA7/RA8, remove one of the rubber caps blocking the greasing ports.
- (2) Grease the ball screws and the whirl-stop according to the following instructions.  
[Ball Screw]  
Adjust the rod to the home position.  
By adjusting it to the home position, the greasing port and the port for ball screws will match inside the main unit.  
Connect the controller and adjust it to the home position.  
Insert the tip of the spray grease in greasing port and inject it for one second.  
One injection time should not exceed one second.  
[Whirl-stop]  
Adjust the rod position above 40mm.  
Insert the tip of the spray grease in greasing port and inject it for one second.  
One injection time should not exceed one second.

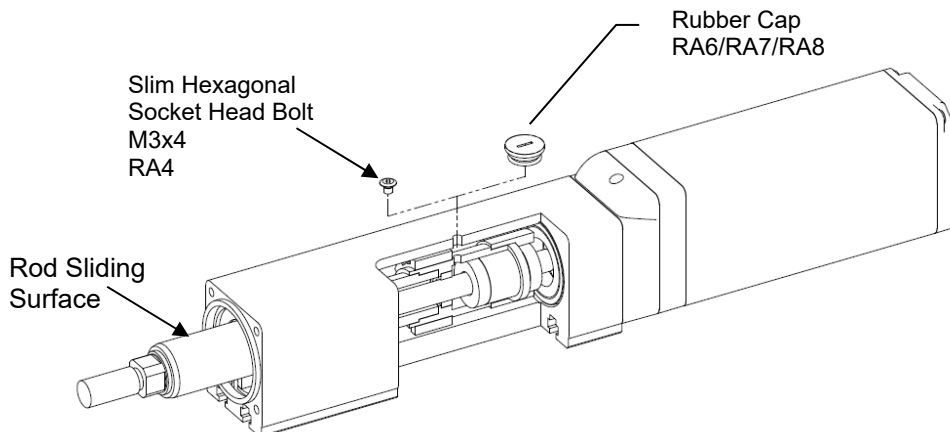

- (3) Clean up the rod (sliding surface) and apply the grease with hands.
- (4) After greasing, move the rod full-stroke to apply the grease thoroughly.

**⚠ Caution:** Supplying too much grease may increase sliding resistance and load to the motor, resulting in a drop of performance.

- In case the grease got into your eye, immediately go see the doctor to get appropriate care. After finishing the grease supply work, wash your hands carefully with water and soap to rinse the grease OFF.



## 5.5 Procedure for Belt Replacement and Tuning

Applicable Units : RA4R, RA6R, RA7R, RA8R

### 5.5.1 Inspection of the Belt

For inspection work, detach the pulley cover with hexagonal wrench and carry it out by visual. For RA4R, RA6R, RA7R, and RA8R, remove two hexagonal socket flat-head bolts (where marked with a circle).

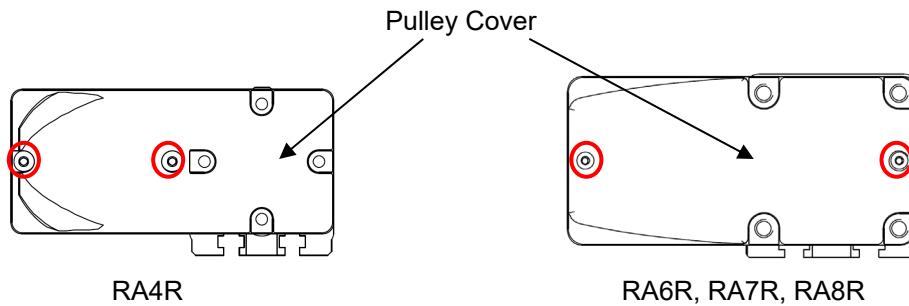

The period of replacement for the belt cannot be clearly defined as the durability of it is impacted so much by the operational conditions.

In generally speaking, it possesses bending life of several million times.

The timing belt gets worn away as the time passes, and it is necessary to have replacement at regular intervals with the following conditions as reference.

- When the gear and belt area show obvious friction.
- When swelling occurs as a result of oil adhesion.
- When damages such as a crack occurs on the belt gear and back side.

Also, for the toothed belt, it is recommended to set the interval of regular replacement cycle when in use under high wire fatigue condition in high acceleration and deceleration because it is difficult to judge the right timing for replacement by checking appearance or looseness of the wires strengthening the belt.

### 5.5.2 Belt to Use

IAI uses the following belt in our plant

Model	IAI Maintenance Part Code	Manufacturer Model Code	
RA4R	TB-RCP6-STRA4R	60S2M148 GB	Rubber, Super torque G Bareback specification (Mitsuboshi Belting Ltd.)
RA6R	TB-RCP6-STRA6R	60S2M182GB	Rubber, Super torque G Bareback specification (Mitsuboshi Belting Ltd.)
RA7R	TB-RCP6-STRA7R	100S3M225 GB	Rubber, Super torque G Bareback specification (Mitsuboshi Belting Ltd.)
RA8R	TB-RCP6-RA8R	275-EV5GT-15	Rubber, EV belt (Gates Unitta Asia)

## 5.5.3 Belt Replacement

[Items required for replacing the motor]

- Belt for Replacement
- Hexagon Wrench 2.5mm(RA4R), 3mm(RA6R/RA7R)  
4mm (RA8R), 2mm (for hexagonal socket flat-head cap screw)
- Phillips screwdriver
- Tension Gauge (that is available for pulling with 200N)
- Long Tie-Band (thin string)

[Procedure]

- 1) For RA4R, RA6R, RA7R, and RA8R, remove two hexagonal socket flat-head bolts (where marked with a circle) with a hexagonal wrench. Detach the pulley cover.

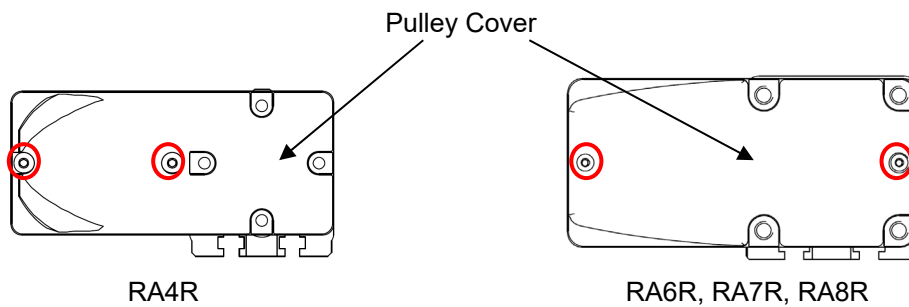

- 2) Remove the four Phillips screws by Phillips screwdriver and remove the motor cover.

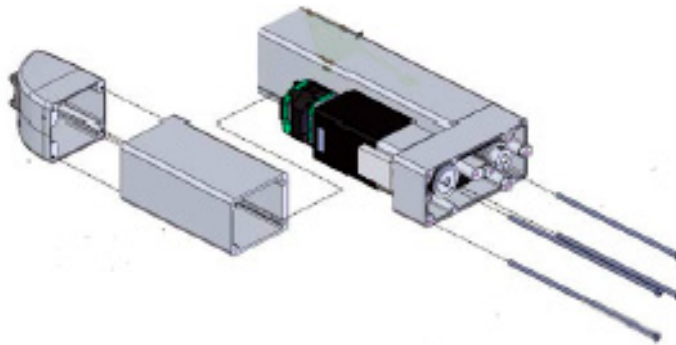

- 3) After tension adjustment of the belt, remove the following bolts and circular washers that are attached for position repeatability of the motor with 2.5mm-sized hexagonal wrench.

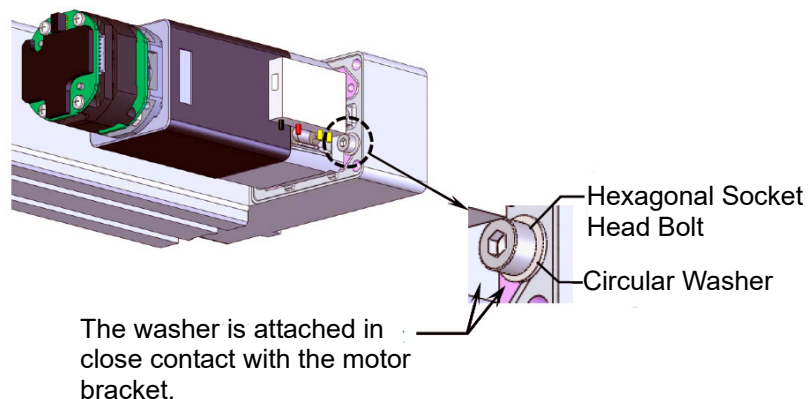

- 4) Loosen the bolts (where marked with a circle; two bolts for RA4R and RA6R, four bolts for RA7R, and RA8R) holding the motor with a 2.5mm-sized (RA4R), 3mm-sized (RA6R/RA7R) or 4 mm-sized (RA8R) hexagonal wrench. Replace the belt if it is necessary.

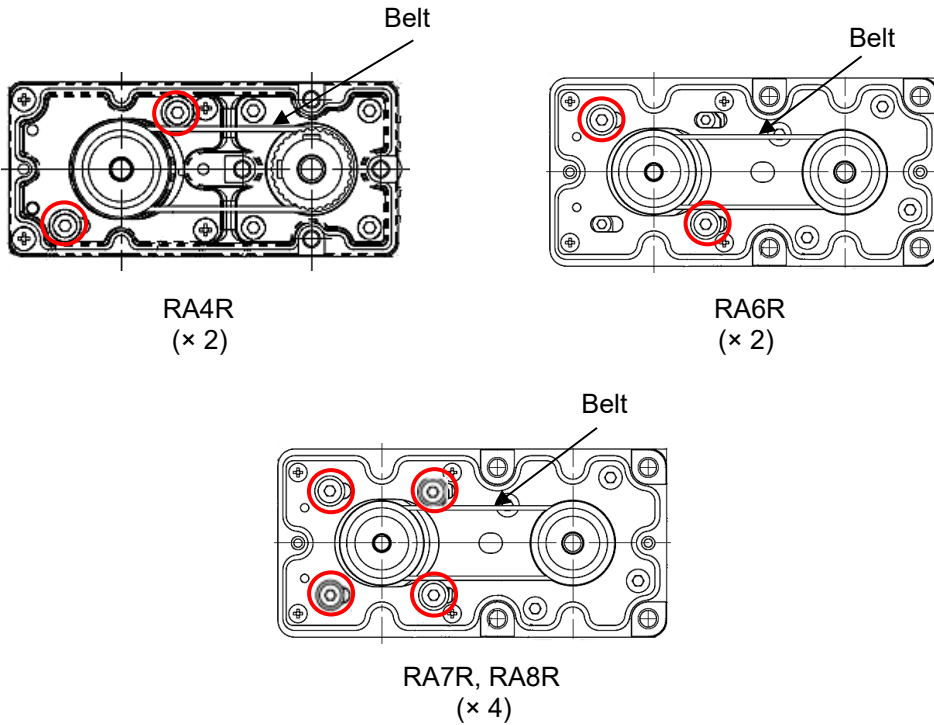

- 5) Adjust the belt tension. Hand a cable band (thin string) on the edge of the motor unit and pull it on a tension gauge with the specified load (specified value of the belt tension). When the load reached the specified, tighten the bolts (where marked with a circle) with a 2.5mm-sized (RA4R), 3mm-sized (RA6R/RA7R), or 4mm-sized (RA8R) hexagonal wrench to hold the unit in the place.

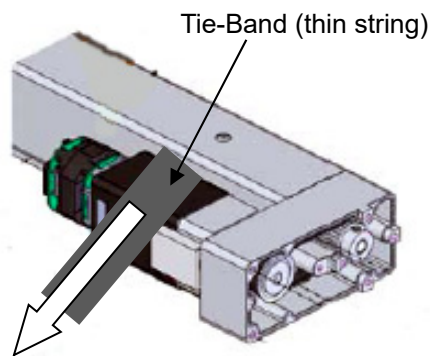

Model	Tension Force
RA4R	20 to 25N
RA6R	25 to 30N
RA7R	80 to 90N
RA8R	180 to 200N

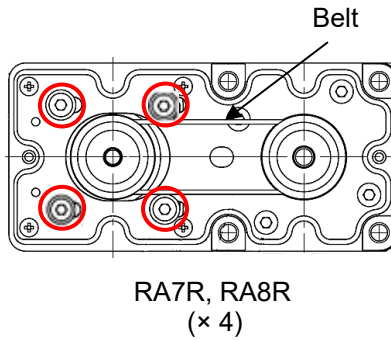
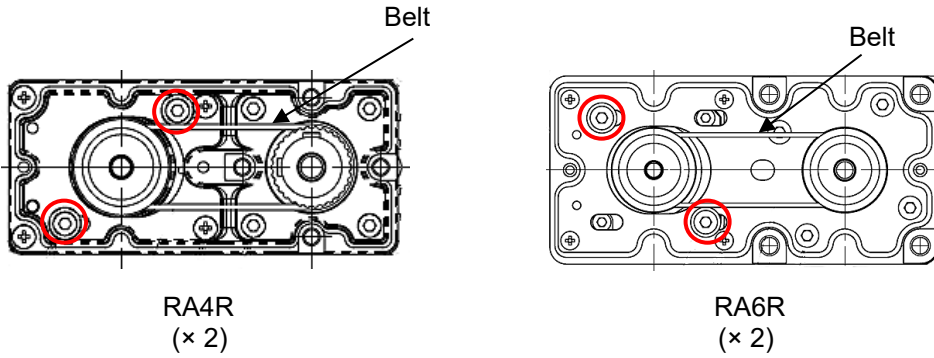

Model	Tightening Torque
RA4R	162N cm
RA6R	323N cm
RA7R	323N cm
RA8R	631N cm

- 6) After tension adjustment of the belt, tighten the following bolts and circular washers attached for position repeatability of the motor in close contact with the motor bracket with 2.5mm-sized hexagonal wrench.

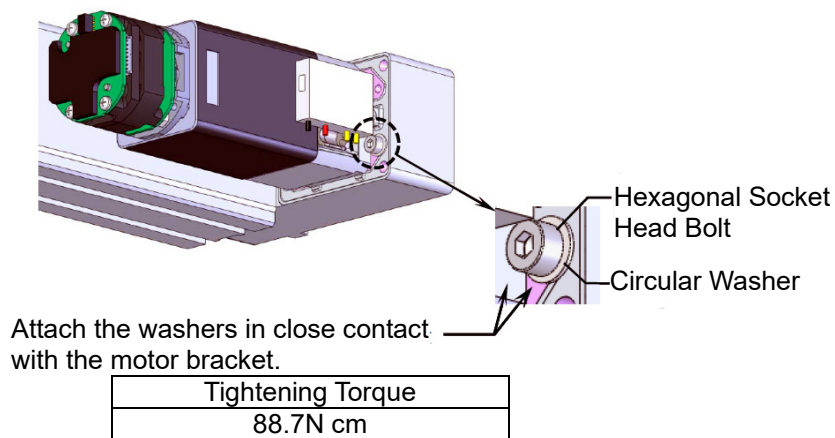

7) Attach the motor cover with four Phillips screws and tighten them with Phillips screwdriver.

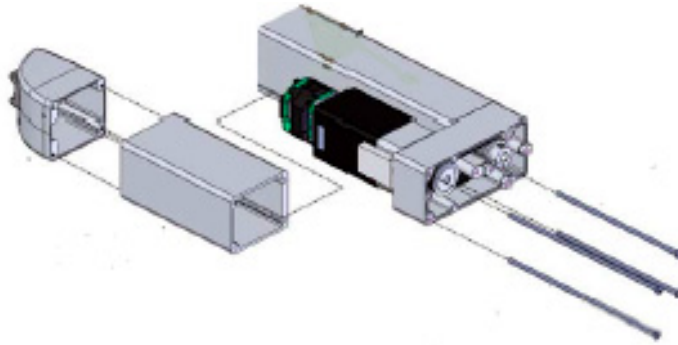

Model	Tightening Torque
RA4R, RA6R, RA7R	41.4N cm
RA8R	96.4N cm

8) Attach the pulley cover with two hexagonal socket flat-head bolts for RA4R, RA6R, RA7R, and RA8R (where marked with a circle) and tighten with a hexagonal wrench.

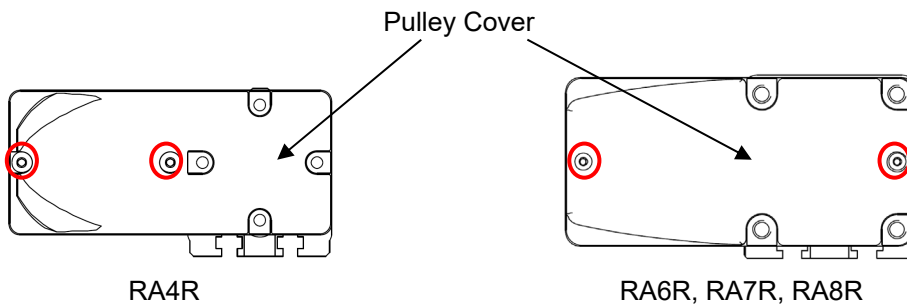

RA4R

RA6R, RA7R, RA8R

Tightening Torque
47.9N cm

## 5.6 Motor Replacement Process



Caution: The encoder part of the motor for replacement and the control board of RCP6S may fail due to static electricity. Please be sure to follow the following precautions during work.

- Do not touch the encoder part of the motor for replacement directly with hands.
- Do not touch the control board directly with hands except when replacing the control board of RCP6S.
- Before replacement work, touch metal objects and the like to release any static electricity from body.
- Do not perform replacement work at the place where static electricity is likely to occur (carpet, etc).

### 5.6.1 RA4C, RA6C, RA7C

[Items required for replacing the motor]

- Motor Unit for Replacement

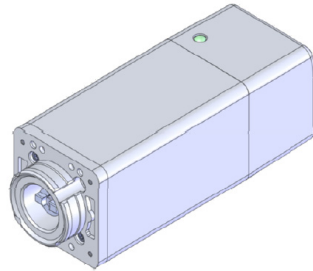

For RCP6

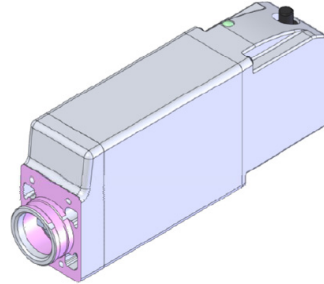

For RCP6S

- Hexagonal wrench set 2mm or 2.5mm-sized

[Procedure]

- 1) Remove the fixing screw affixing the actuator and the motor unit with a 2mm-sized (RA4C, RA6C) or 2.5mm-sized (RA7C) hexagonal wrench.
- 2) Detach the motor unit.

For Fixed screws actuator and Motor Unit

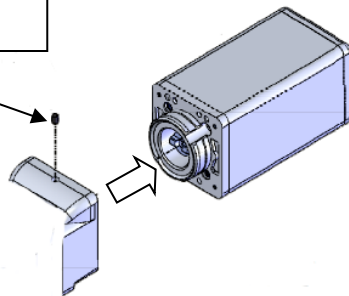

- 3) Make the profiles on the actuator side and motor unit side aligned so the projection matches to the slit.

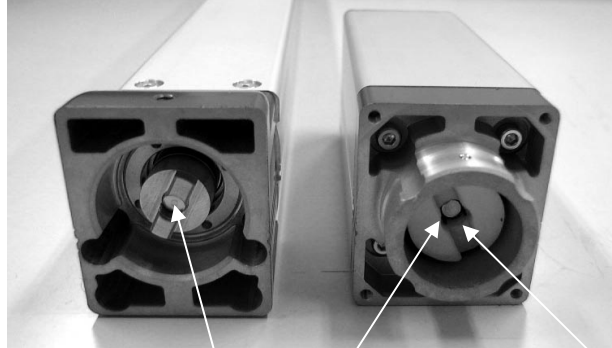

Make the projection and slit matched with each other.

Apply grease to the coupling part. NOXLUB TL1010 grease made by NOK

- 4) Attach the motor unit for replacement with the projection being matched with the slit.
- 5) Tighten the fixing screw to affixing the motor unit to the actuator with 2mm-sized (RA4C, RA6C) or 2.5mm-sized (RA7C) hexagonal wrench.

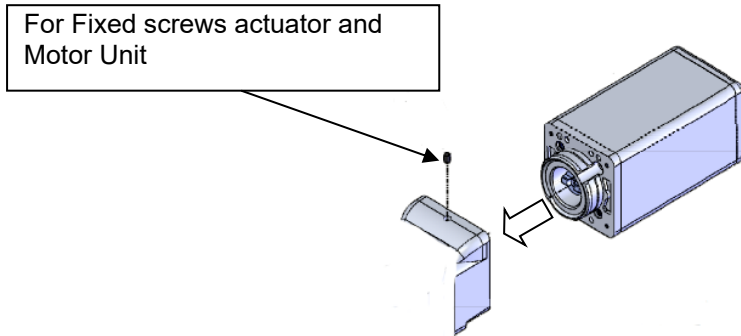

Model	Tightening Torque
RA4C, RA6C	167N cm
RA7C	353N cm

- 6) Make sure to conduct a home return on a PC or a touch panel teaching after motor replacement.

## 5.6.2 RA8C

[Items required for replacing the motor]

- Hexagonal wrench set
- Phillips screwdriver
- Motor for Replacement

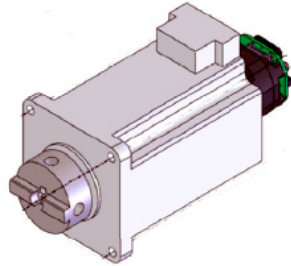

Replacement Motor

[Procedure]

- 1) Remove the four Phillips screws holding the motor cover with Phillips screwdriver. The motor cover can be detached.
- 2) Disconnect the motor • encoder connector.
- 3) Detach the motor cover.

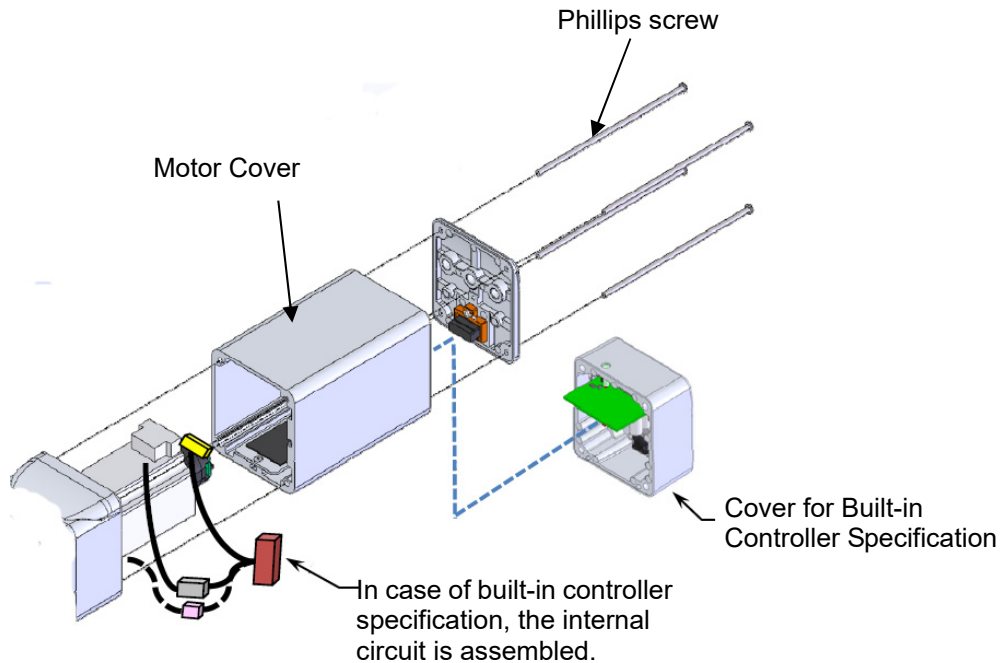

- 4) Remove the four hexagonal socket head cap bolts (M4 ×15 w/o brake, M4 ×12 with brake) holding the motor with using a 3mm-sized hexagonal wrench.



- 5) Pull out the motor.

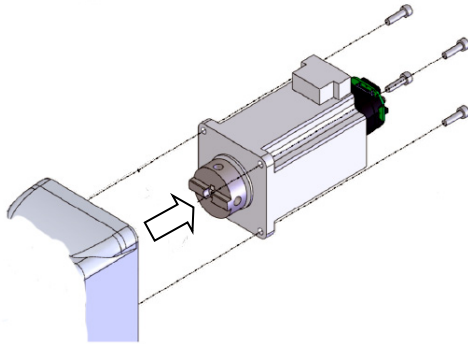

- 6) Make the profiles on the actuator side and motor unit side aligned so the projection matches to the slit.

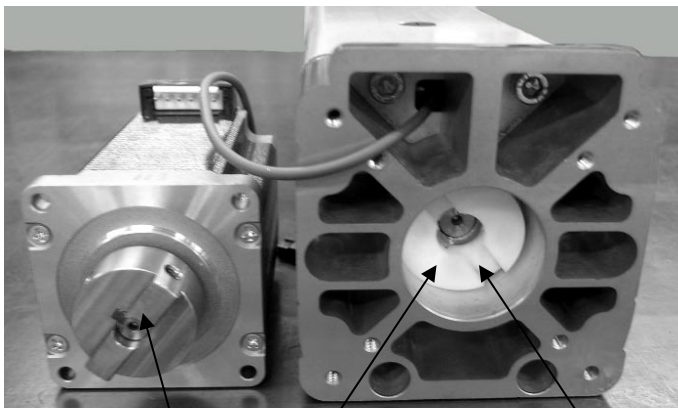

Make the projection and slit matched with each other.

Apply grease to the coupling part.  
TL101Y grease made by NOK

- 7) Insert the motor to the main body.
- 8) Affix the motor with the four bolt (M4 ×15 w/o brake, M4 ×12 with brake) and tighten them with using a 3mm-sized hexagonal wrench.

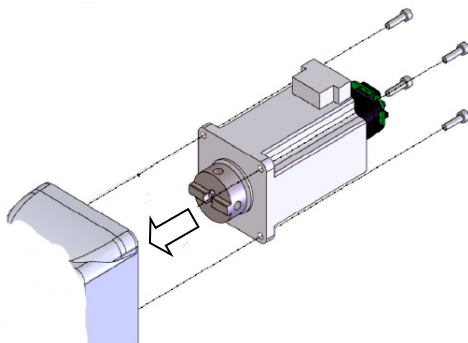

Tightening Torque : 176N cm

- 9) Attach the motor cover and plug in the motor connector.  
Pay attention not to involve the wires to the bolt guilds when attaching the motor cover.
- 10) Plug in the motor • encoder connector.
- 11) Affix the motor cover with four Phillips screws and tighten them with Phillips screwdriver.

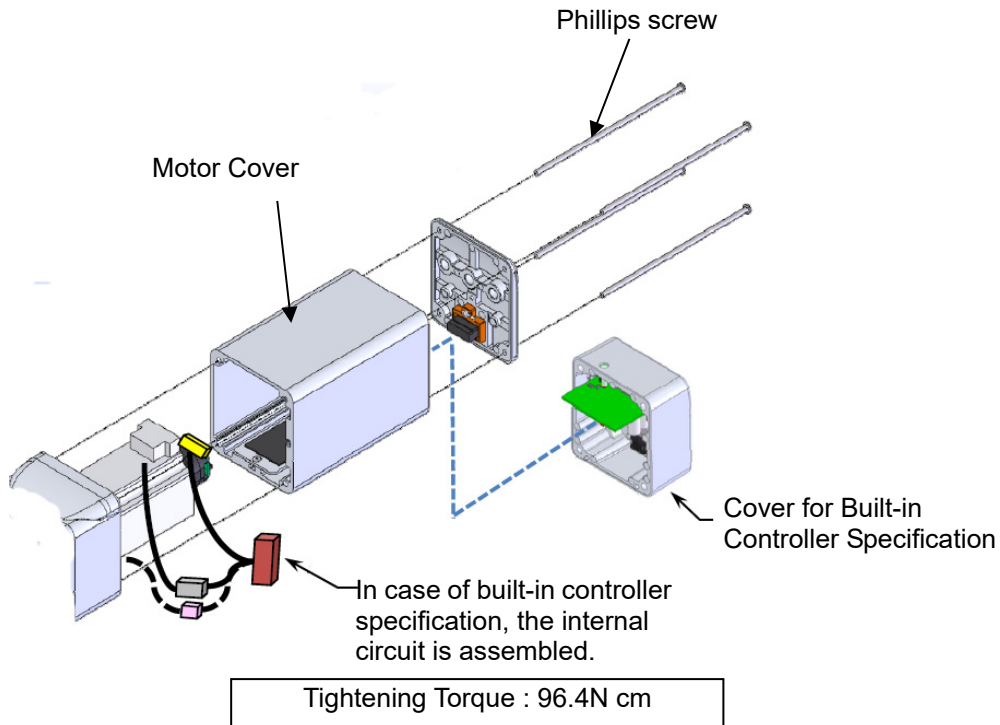

- 12) Make sure to conduct a home return on a PC or a touch panel teaching after motor replacement.

## 5.6.3 RA4R, RA6R, RA7R, RA8R

[Items required for replacing the motor]

- Motor unit for replacement

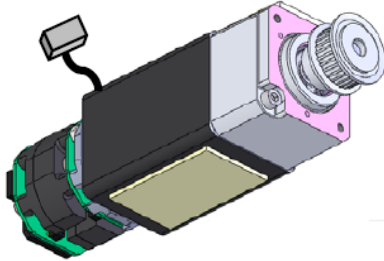

- Hexagon wrench set 2.5mm(RA4R), 3mm(RA6R/RA7R)  
4mm(RA8R), 2mm(for hexagonal socket bolts)
- Phillips screwdriver
- Tension gauge (capable thing of tensioning to 200N or greater)
- Strong string or long tie-band

[Procedure]

- 1) For RA4R, RA6R, RA7R, and RA8R, remove two hexagonal socket flat-head bolts (where marked with a circle) with a hexagonal wrench. Detach the pulley cover.

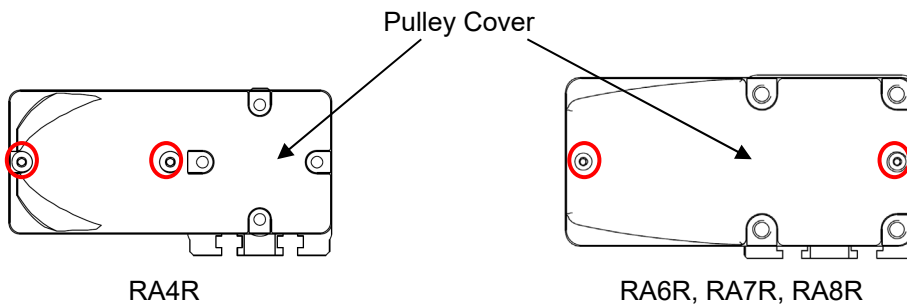

- 2) Remove the four Phillips screws by Phillips screwdriver and remove the motor cover.

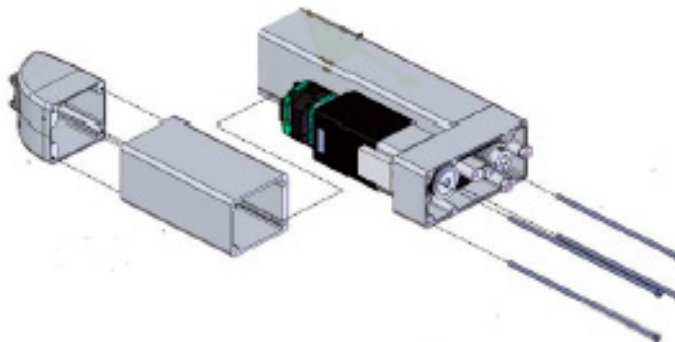

- 3) If the belt is to be replaced at the same time, remove the following bolts and circular washers that are mounted for position repeatability of the motor by 2.5mm-sized hexagonal wrench, after tension adjustment of the belt,

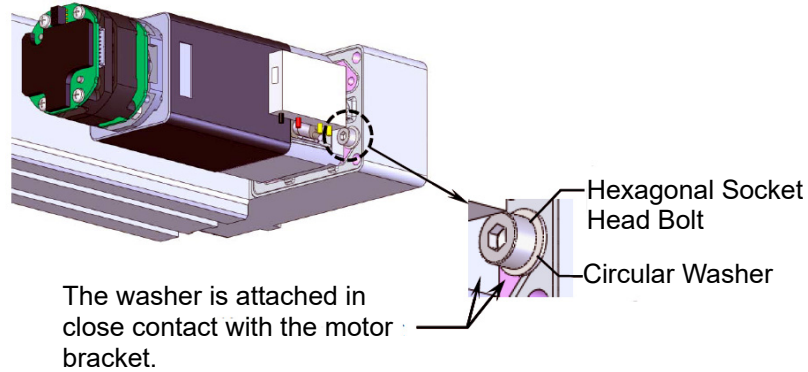

- 4) Loosen the bolts (where marked with a circle; two bolts for RA4R and RA6R, four bolts for RA7R, and RA8R) holding the motor with a 2.5mm-sized (RA4R), 3mm-sized (RA6R/RA7R) or 4mm-sized (RA8R) hexagonal wrench. Replace the belt if it is necessary.

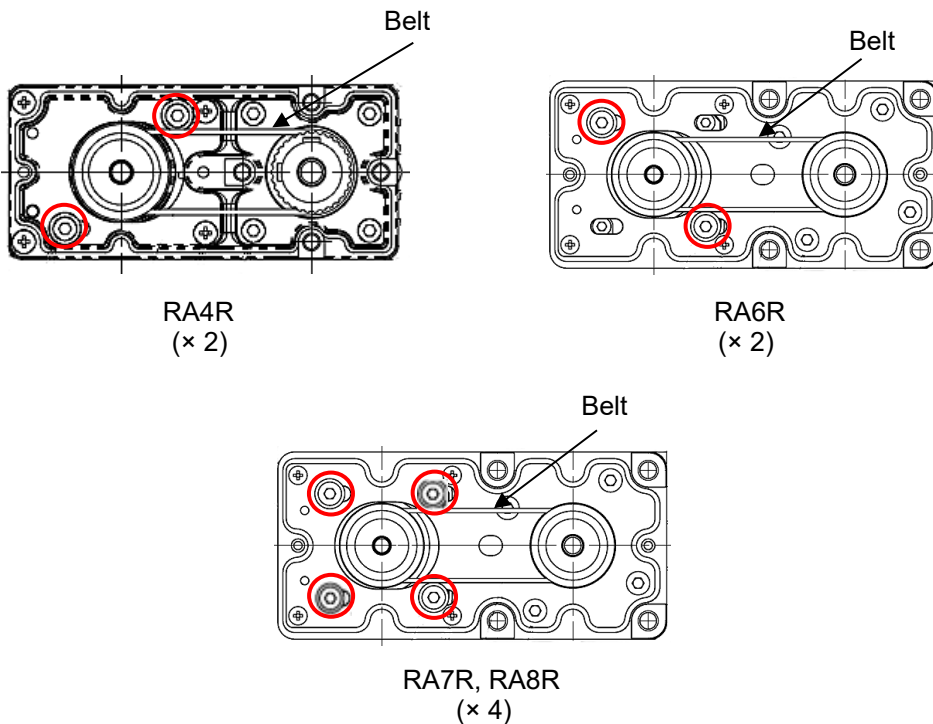

- 5) Detach the belt off the pulleys.
- 6) Pull out four bolts and remove the motor unit.

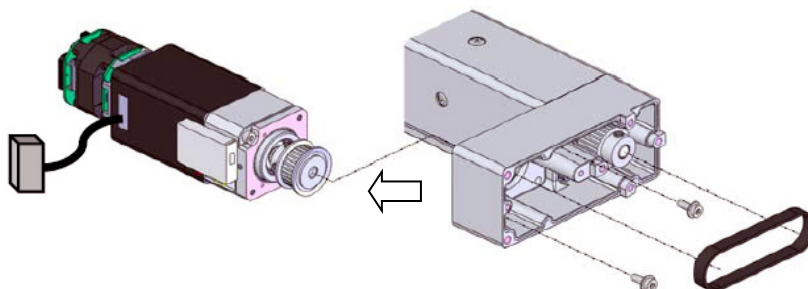

- 7) Install the new motor and temporarily tighten the tension adjustment bolts (encircled parts). Hang the timing belt.

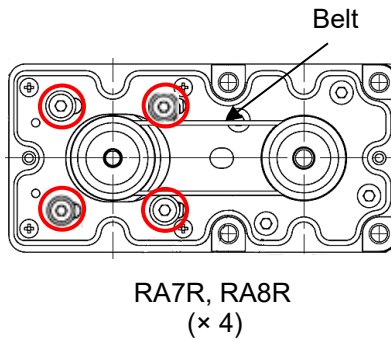
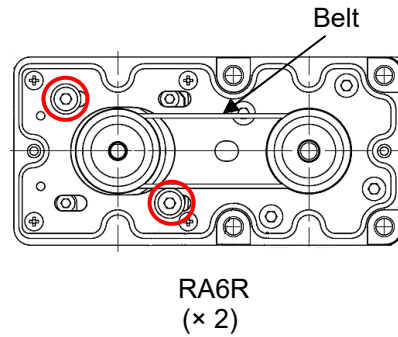
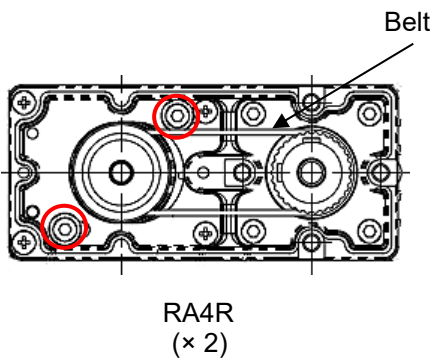
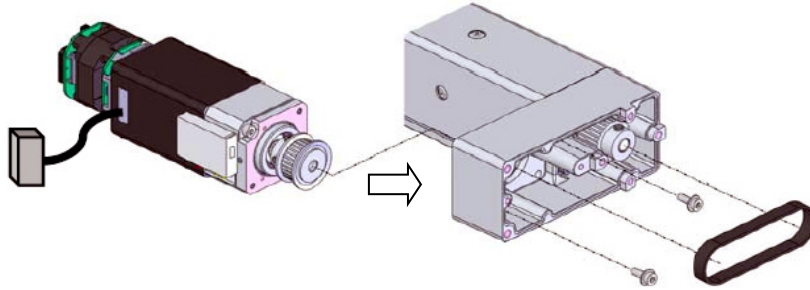

(Note) If the belt is not replaced at the same time and the following hexagonal socket bolts and circular washers are not removed, there is no need to adjust tension of the belt as prescribed in 8).

Hand a cable band (thin string) on the edge of the motor unit and pull it. When it is abutting against the hexagonal socket bolt, tighten the bolt (where marked with a circle) with 2.5mm-sized (RA4R), 3mm-sized (RA6R/RA7R), or 4mm-sized (RA8R) hexagonal wrench to hold the unit in the place.

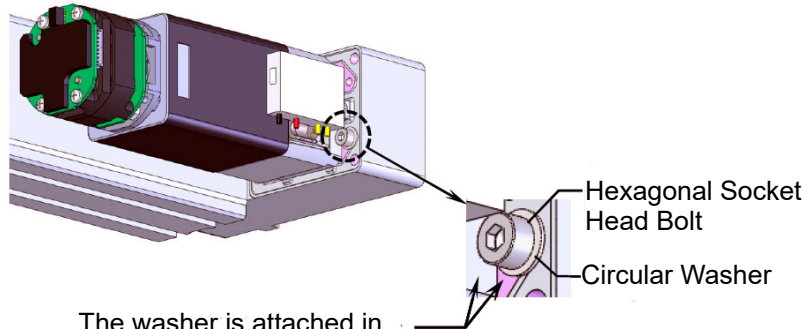

The washer is attached in close contact with the motor bracket.

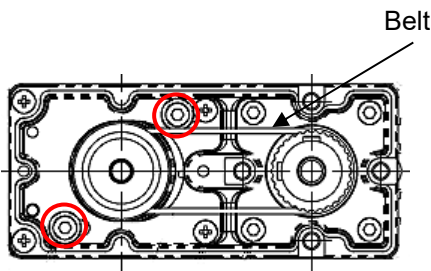

RA4R  
(× 2)

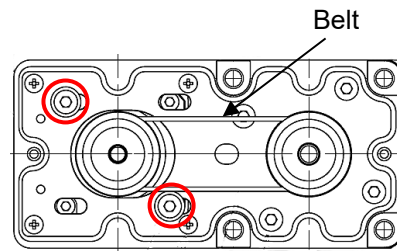

RA6R  
(× 2)

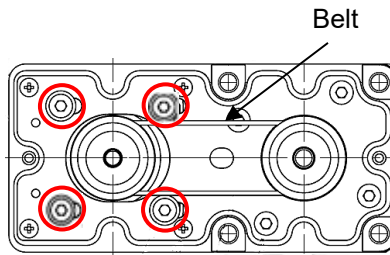

RA7R, RA8R  
(× 4)

Model	Tightening Torque
RA4R	162N cm
RA6R	323N cm
RA7R	323N cm
RA8R	631N cm

- 8) If the belt has been replaced at the same time, adjust the tension of the belt.  
 Hand a cable band (thin string) on the edge of the motor unit and pull it on a tension gauge with the specified load (specified value of the belt tension).  
 When the load reached the specified, tighten the bolts (where marked with a circle) with a 2.5mm-sized (RA4R), 3mm-sized (RA6R/RA7R), or 4mm-sized (RA8R) hexagonal wrench to hold the unit in the place.

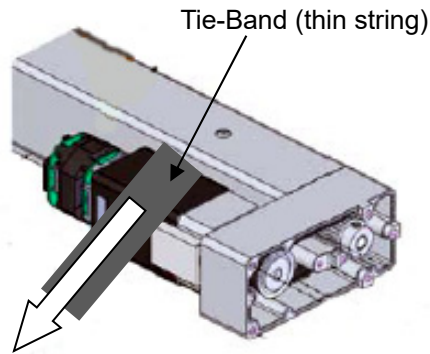

Model	Tension Force
RA4R	20 to 25N
RA6R	25 to 30N
RA7R	80 to 90N
RA8R	180 to 200N

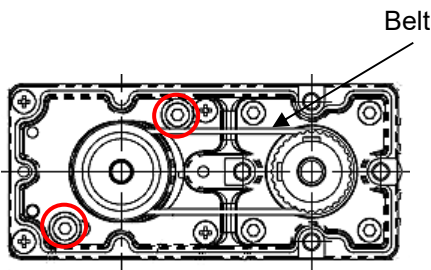

RA4R  
(× 2)

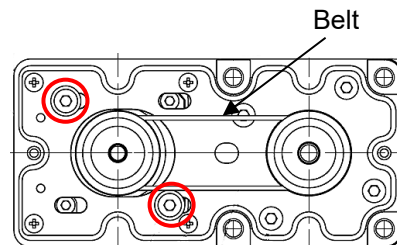

RA6R  
(× 2)

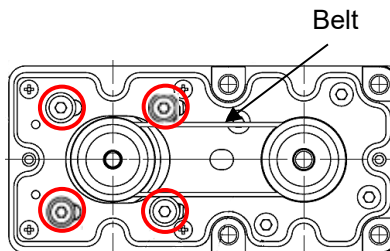

RA7R, RA8R  
(× 4)

Model	Tightening Torque
RA4R	162N cm
RA6R	323N cm
RA7R	323N cm
RA8R	631N cm



- 9) If the belt has been replaced at the same time, tighten the following bolts and circular washers that are mounted for position repeatability of the motor with 2.5-mm sized hexagonal wrench after tension adjustment of the belt.

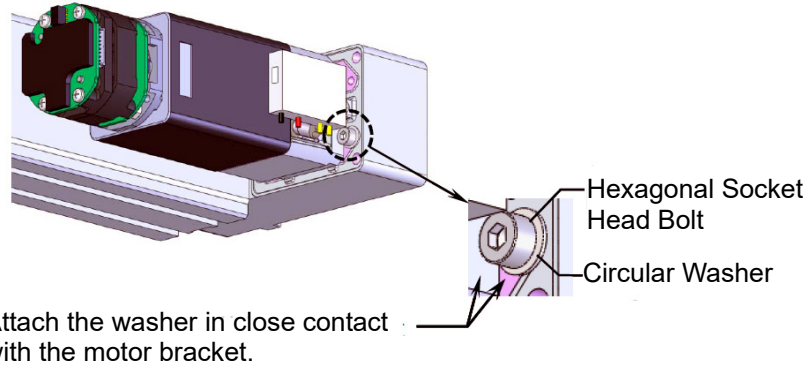

Tightening Torque
88.7N cm

- 10) Attach the motor cover with four Phillips screws and tighten them with Phillips screwdriver.

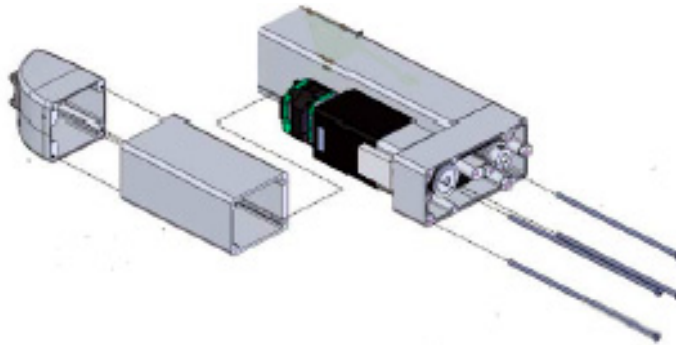

Model	Tightening Torque
RA4R, RA6R, RA7R	41.4N cm
RA8R	96.4N cm



- 11) Attach the pulley cover with two hexagonal socket flat-head bolts for RA4R, RA6R, RA7R, and RA8R (where marked with a circle) and tighten with a hexagonal wrench.

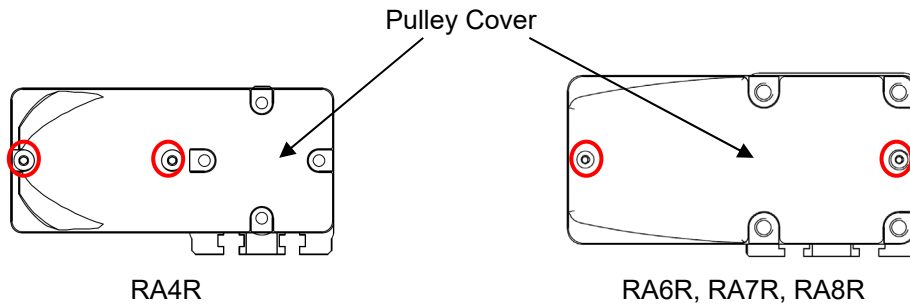

Tightening Torque
47.9N cm

- 12) Make sure to conduct a home return on a PC or a touch panel teaching after motor replacement.

## 6. External Dimensions

### 6.1 Standard Specification RCP6-RA4C

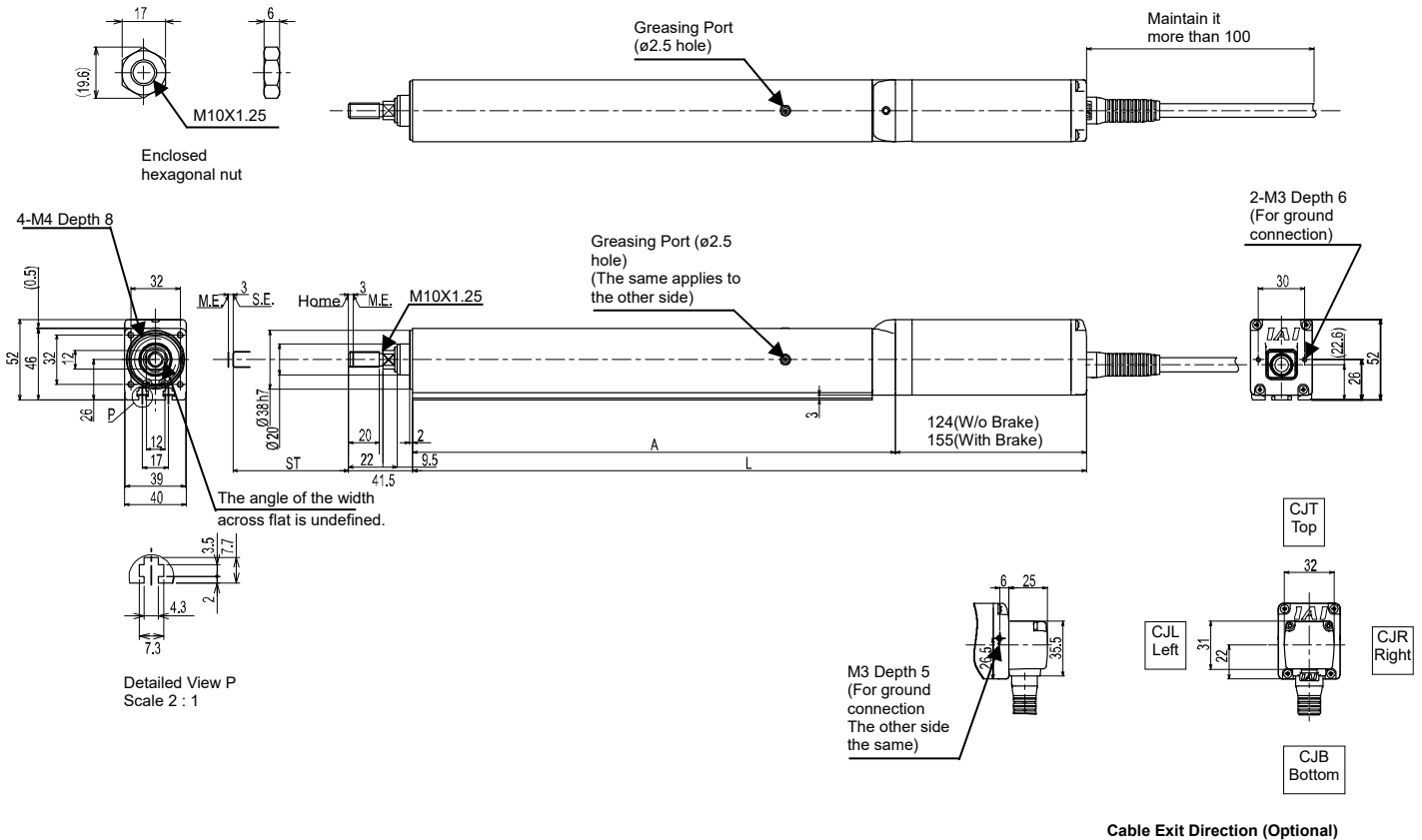

ST : Stroke  
M.E. : Mechanical End  
S.E. : Stroke End

Stroke	L		A	Mass [kg]	
	W/o Brake	With Brake		W/o Brake	With Brake
50	287	318	163	1.4	1.5
100	337	368	213	1.6	1.7
150	387	418	263	1.7	1.9
200	437	468	313	1.9	2.1

(Note) L dimensions described in the table are those with no cable exit direction (option). For cable exit direction types (option), the dimensions are longer in 25mm.

## 6.2 Built-in Controller Specification RCP6S-RA4C

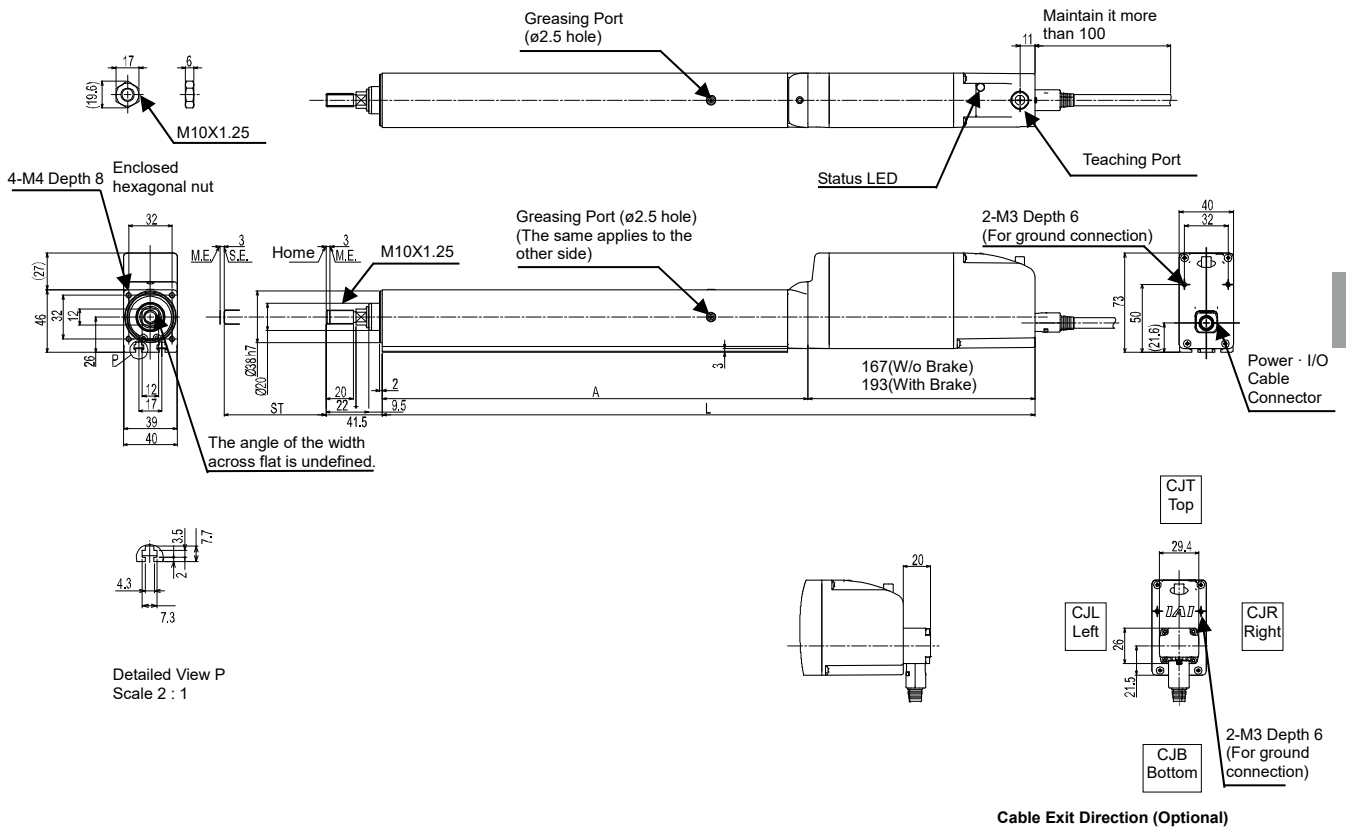

ST : Stroke  
M.E. : Mechanical End  
S.E. : Stroke End

Stroke	L		A	Mass [kg]	
	W/o Brake	With Brake		W/o Brake	With Brake
50	330	356	163	1.6	1.7
100	380	406	213	1.8	1.9
150	430	456	263	1.9	2.1
200	480	506	313	2.1	2.3

(Note) L dimensions described in the table are those with no cable exit direction (option). For cable exit direction types (option), the dimensions are longer in 20mm.

### 6.3 Standard Specification RCP6-RA6C

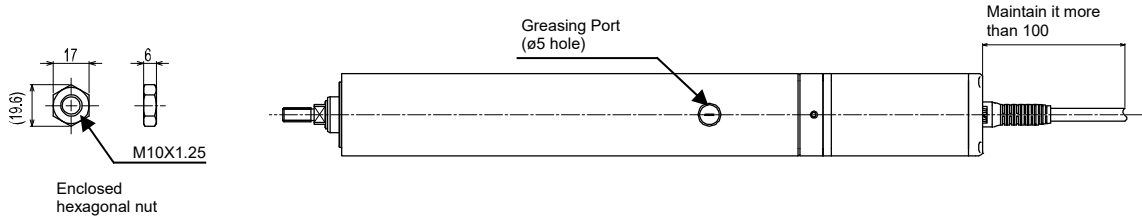

6. External Dimensions

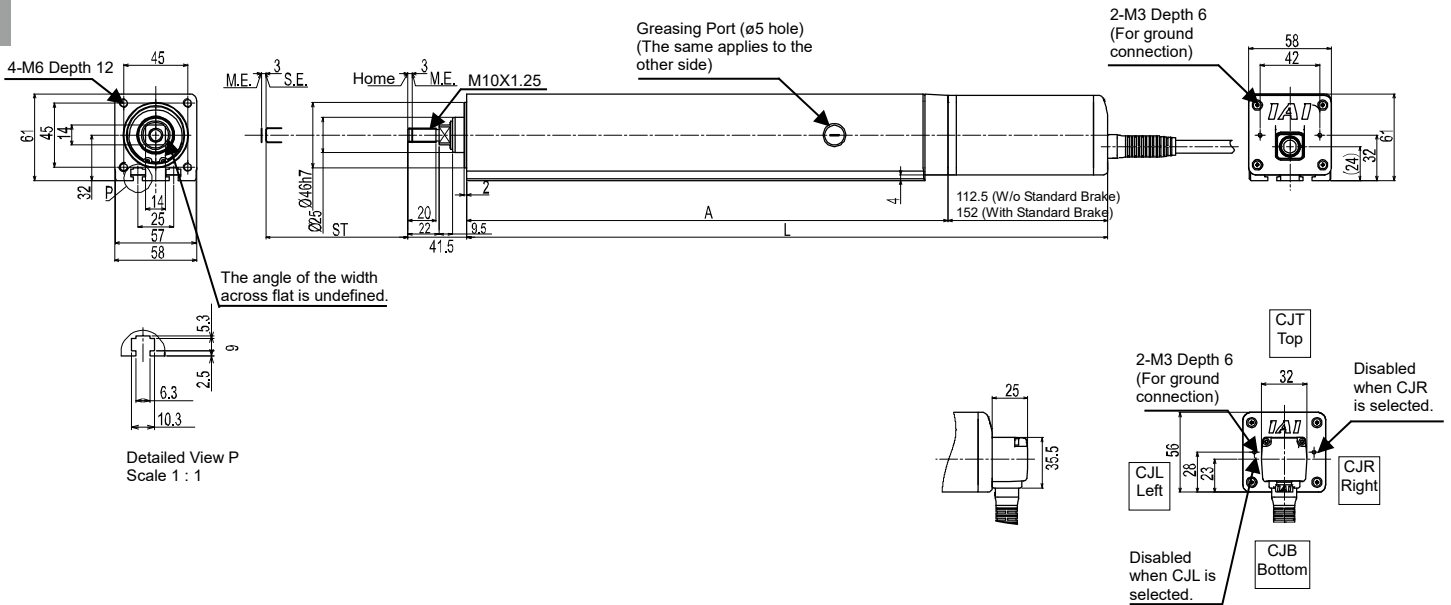

ST : Stroke  
M.E. : Mechanical End  
S.E. : Stroke End

Cable Exit Direction (Optional)

Stroke	L		A	Mass [kg]	
	W/o Brake	With Brake		W/o Brake	With Brake
50	301.5	341	189	2.5	2.7
100	351.5	391	239	2.9	3.1
150	401.5	441	289	3.3	3.5
200	451.5	491	339	3.6	3.9
250	501.5	541	389	4.0	4.3
300	551.5	591	439	4.4	4.7

(Note) L dimensions described in the table are those with no cable exit direction (option). For cable exit direction types (option), the dimensions are longer in 25mm.

## 6.4 Built-in Controller Specification RCP6S-RA6C

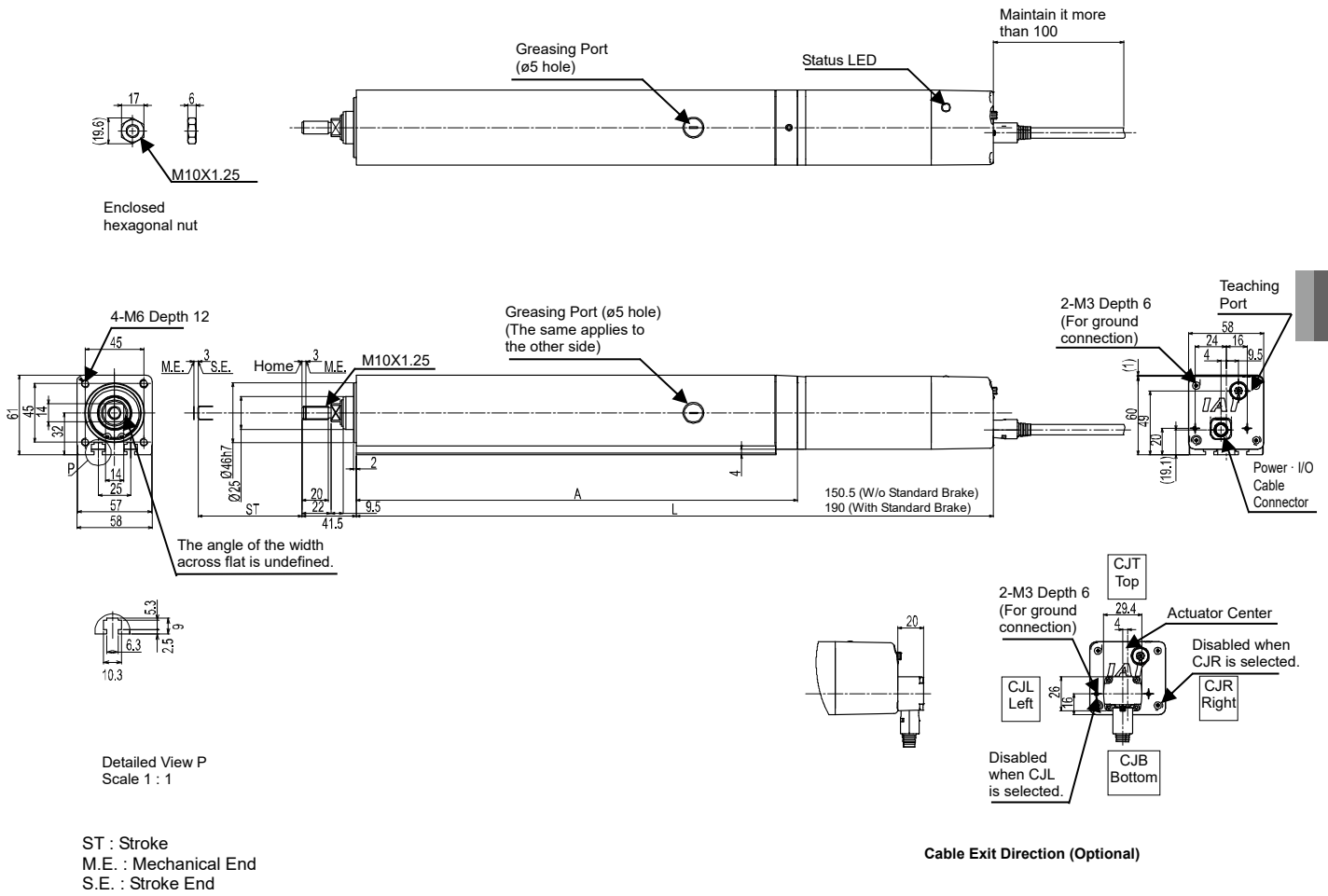

ST : Stroke  
M.E. : Mechanical End  
S.E. : Stroke End

Stroke	L		A	Mass [kg]	
	W/o Brake	With Brake		W/o Brake	With Brake
50	339.5	379	189	2.6	2.9
100	389.5	429	239	3.0	3.2
150	439.5	479	289	3.4	3.6
200	489.5	529	339	3.8	4.0
250	539.5	579	389	4.2	4.4
300	589.5	629	439	4.6	4.8

(Note) L dimensions described in the table are those with no cable exit direction (option). For cable exit direction types (option), the dimensions are longer in 20mm.

## 6.5 Standard Specification RCP6-RA7C

### 6. External Dimensions

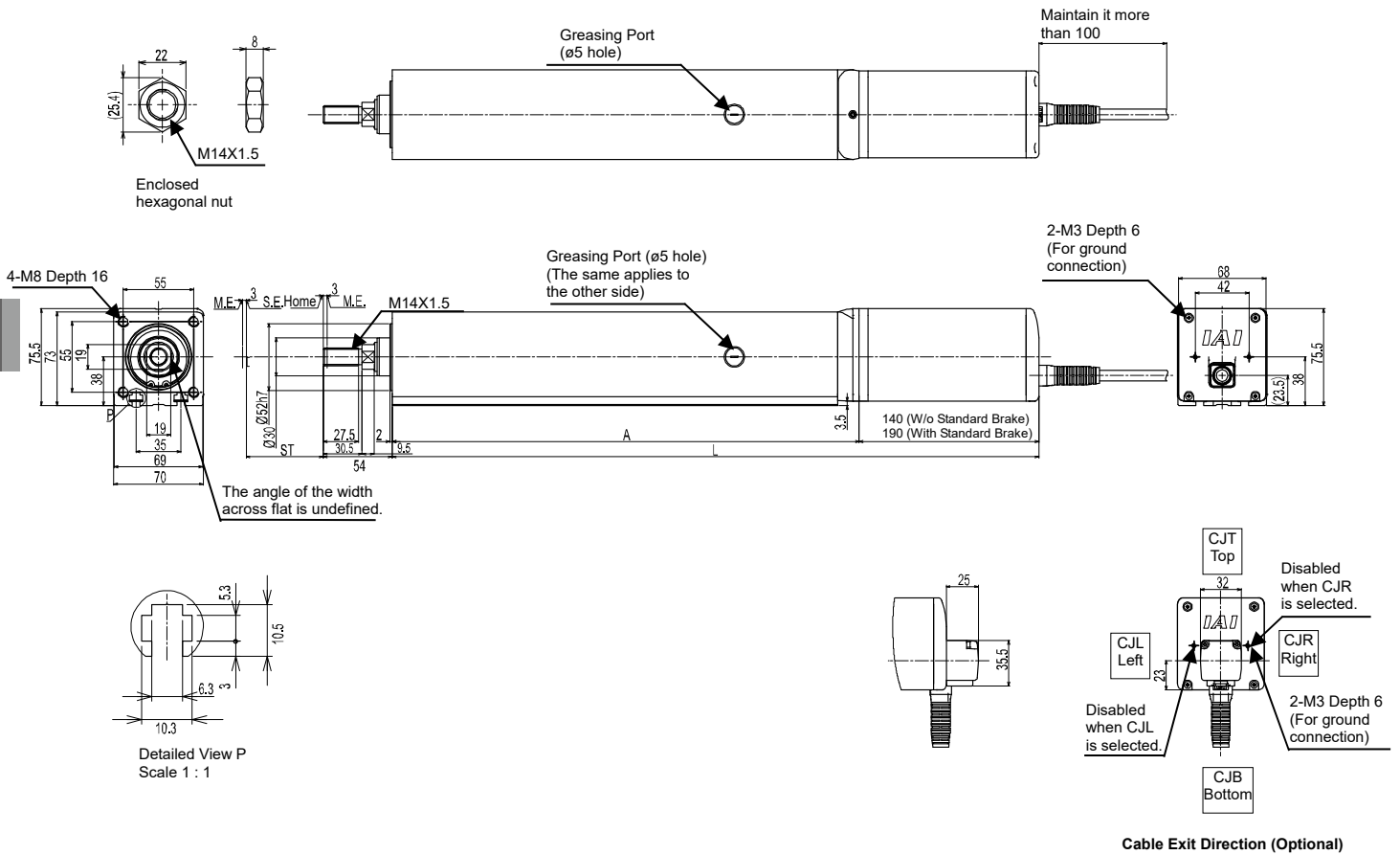

ST : Stroke  
M.E. : Mechanical End  
S.E. : Stroke End

Stroke	L		A	Mass [kg]	
	W/o Brake	With Brake		W/o Brake	With Brake
50	354.5	404.5	214.5	4.5	4.9
100	404.5	454.5	264.5	5.1	5.5
150	454.5	504.5	314.5	5.6	6.0
200	504.5	554.5	364.5	6.2	6.6
250	554.5	604.5	414.5	6.7	7.2
300	604.5	654.5	464.5	7.3	7.7

(Note) L dimensions described in the table are those with no cable exit direction (option). For cable exit direction types (option), the dimensions are longer in 25mm.

## 6.6 Built-in Controller Specification RCP6S-RA7C

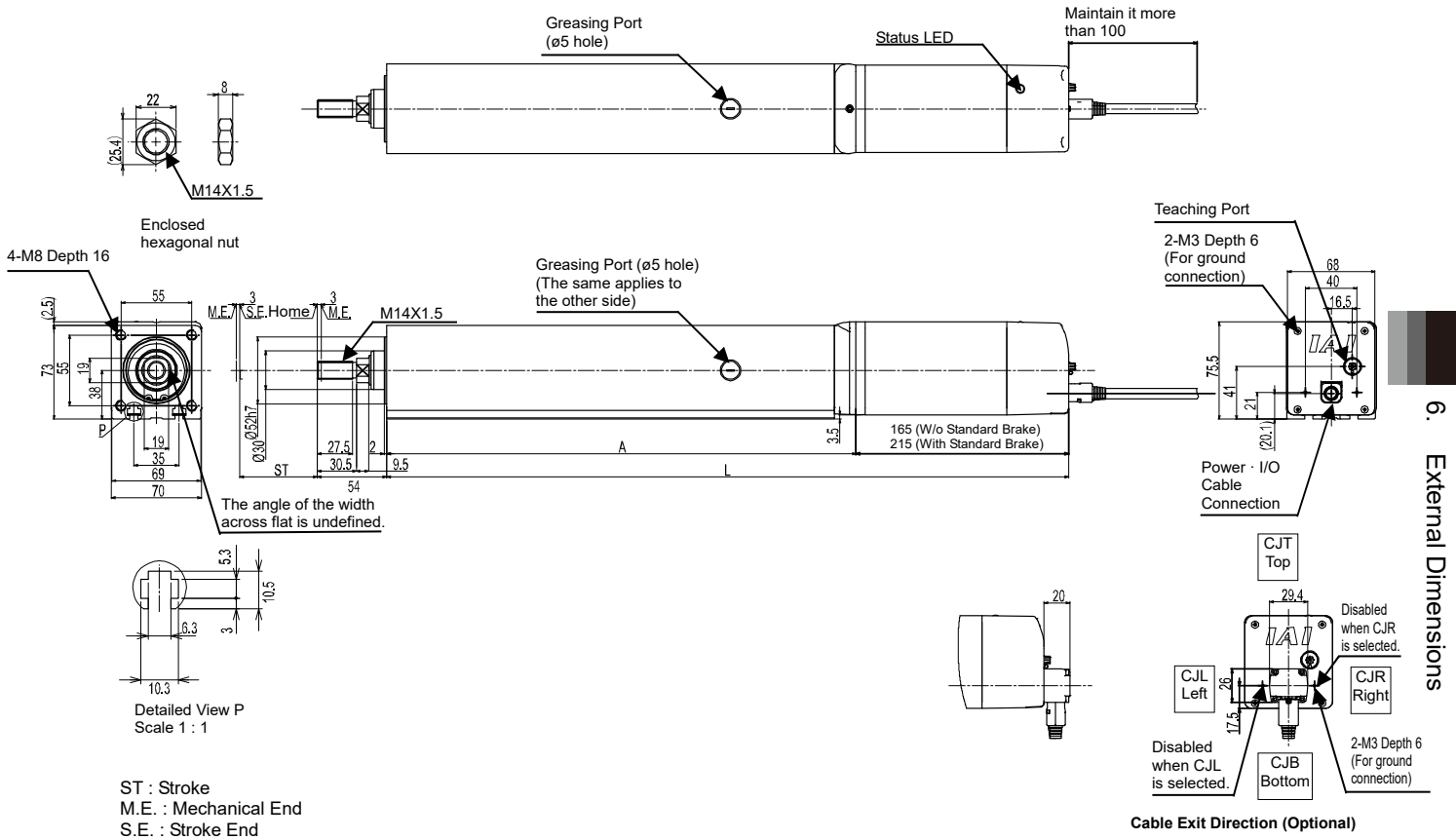

6. External Dimensions

Stroke	L		A	Mass [kg]	
	W/o Brake	With Brake		W/o Brake	With Brake
50	379.5	429.5	214.5	4.7	5.1
100	429.5	479.5	264.5	5.2	5.7
150	479.5	529.5	314.5	5.8	6.2
200	529.5	579.5	364.5	6.3	6.8
250	579.5	629.5	414.5	6.9	7.3
300	629.5	679.5	464.5	7.5	7.9

(Note) L dimensions described in the table are those with no cable exit direction (option). For cable exit direction types (option), the dimensions are longer in 20mm.





## 6.8 Built-in Controller Specification RCP6S-RA8C

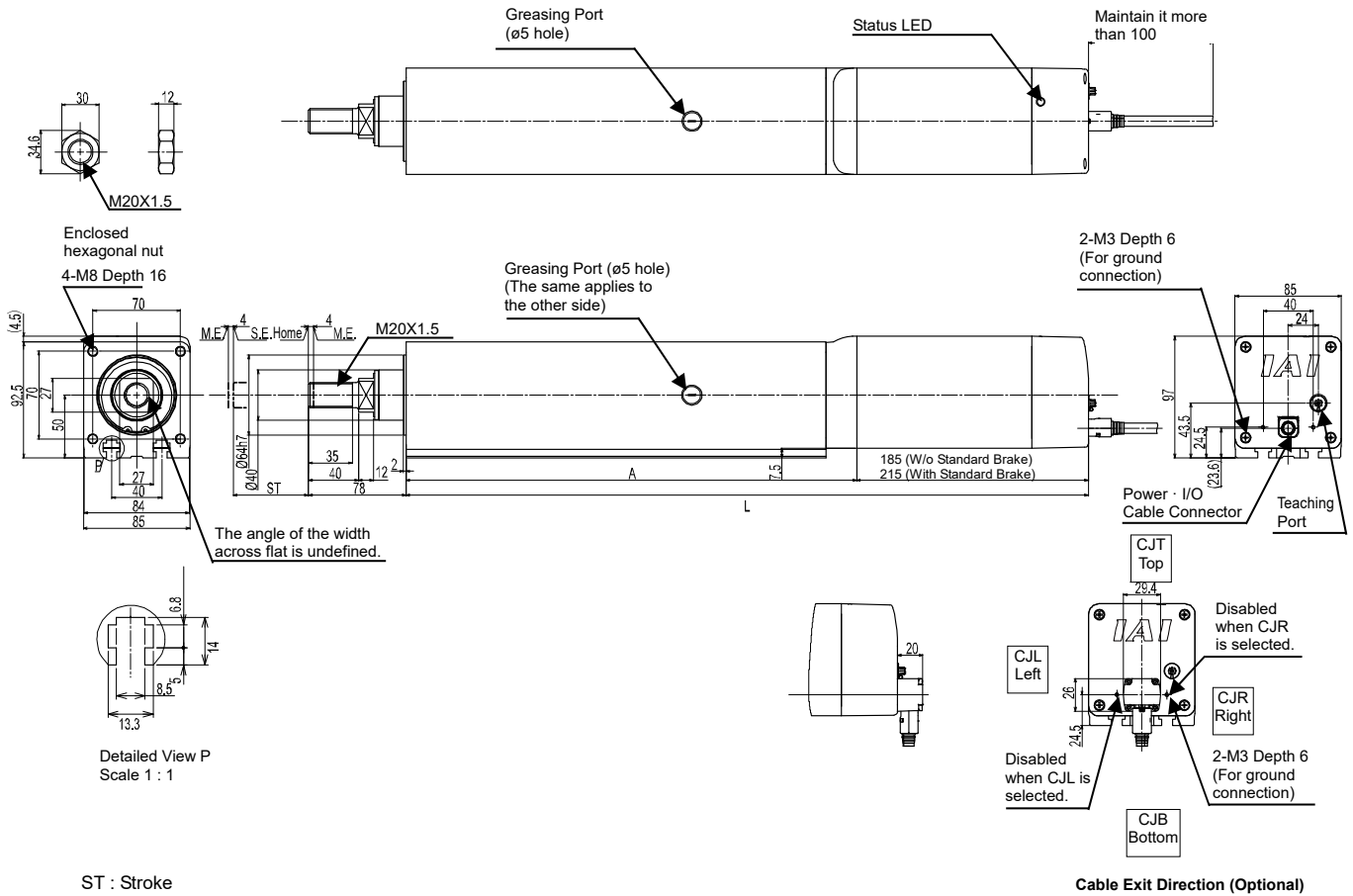

ST : Stroke  
M.E. : Mechanical End  
S.E. : Stroke End

Stroke	L		A	Mass [kg]	
	W/o Brake	With Brake		W/o Brake	With Brake
50	445	475	260	8.1	8.7
100	495	525	310	9.0	9.5
150	545	575	360	9.8	10.4
200	595	625	410	10.6	11.2
250	645	675	460	11.4	12.0
300	695	725	510	12.3	12.8

(Note) L dimensions described in the table are those with no cable exit direction (option). For cable exit direction types (option), the dimensions are longer in 20mm.





## 6.11 Built-in Controller Specification RCP6S-RA4R Top Side-Mounted (Model: MT)

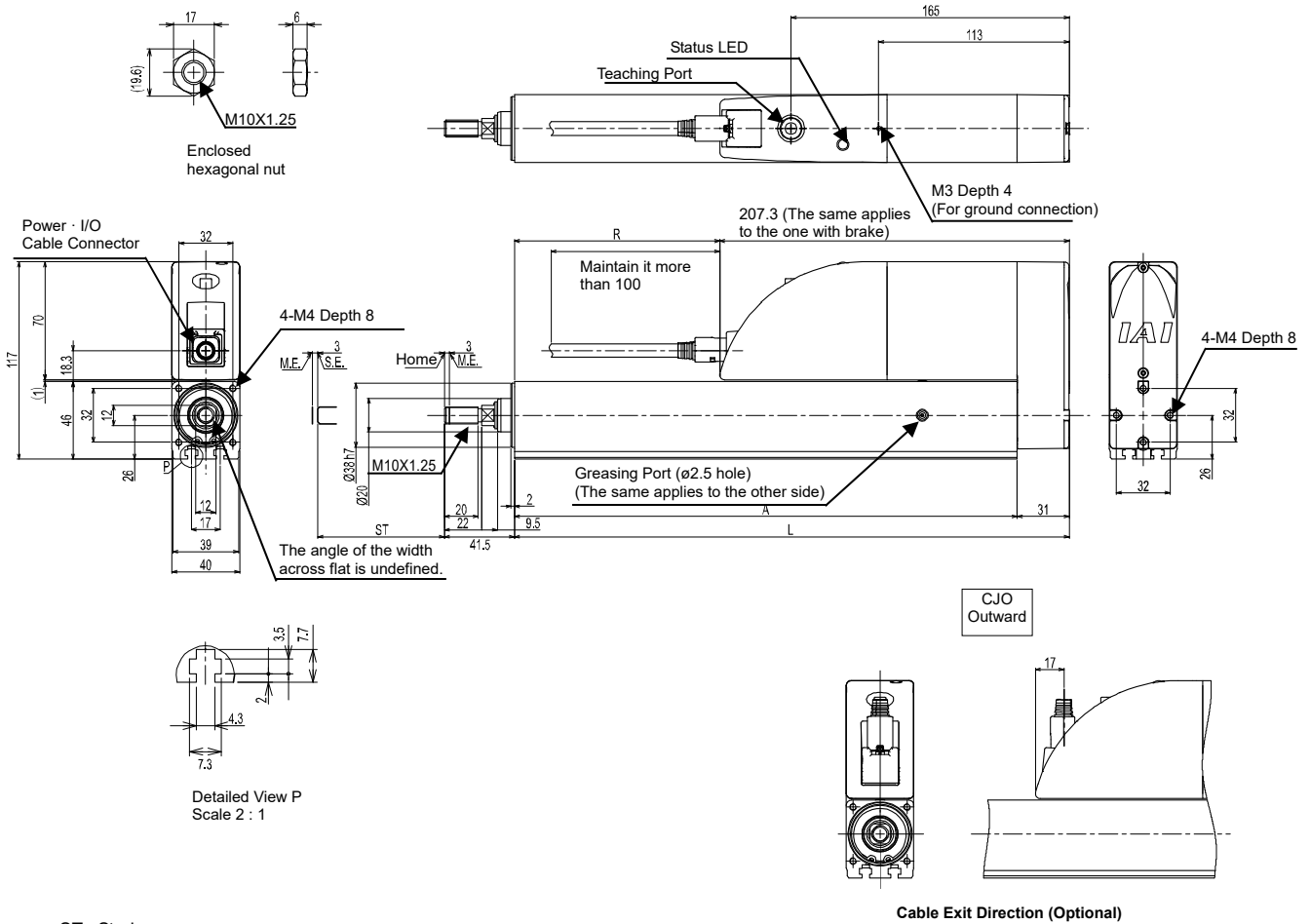

ST : Stroke  
M.E. : Mechanical End  
S.E. : Stroke End

Stroke	S	T	R	Mass [kg]	
				W/o Brake	With Brake
50	179	148	-28.3	1.6	1.7
100	229	198	21.7	1.8	1.9
150	279	248	71.7	2	2.1
200	329	298	121.7	2.2	2.3

(Note) When R dimension is negative, the end of the motor unit is located before the base end surface.

## 6.12 Built-in Controller Specification RCP6S-RA4R Left Side-Mounted (Model: ML)

(Note) For Right Side-Mounted (model: MR), side-mounted motor will be on the right side in the drawing beneath.

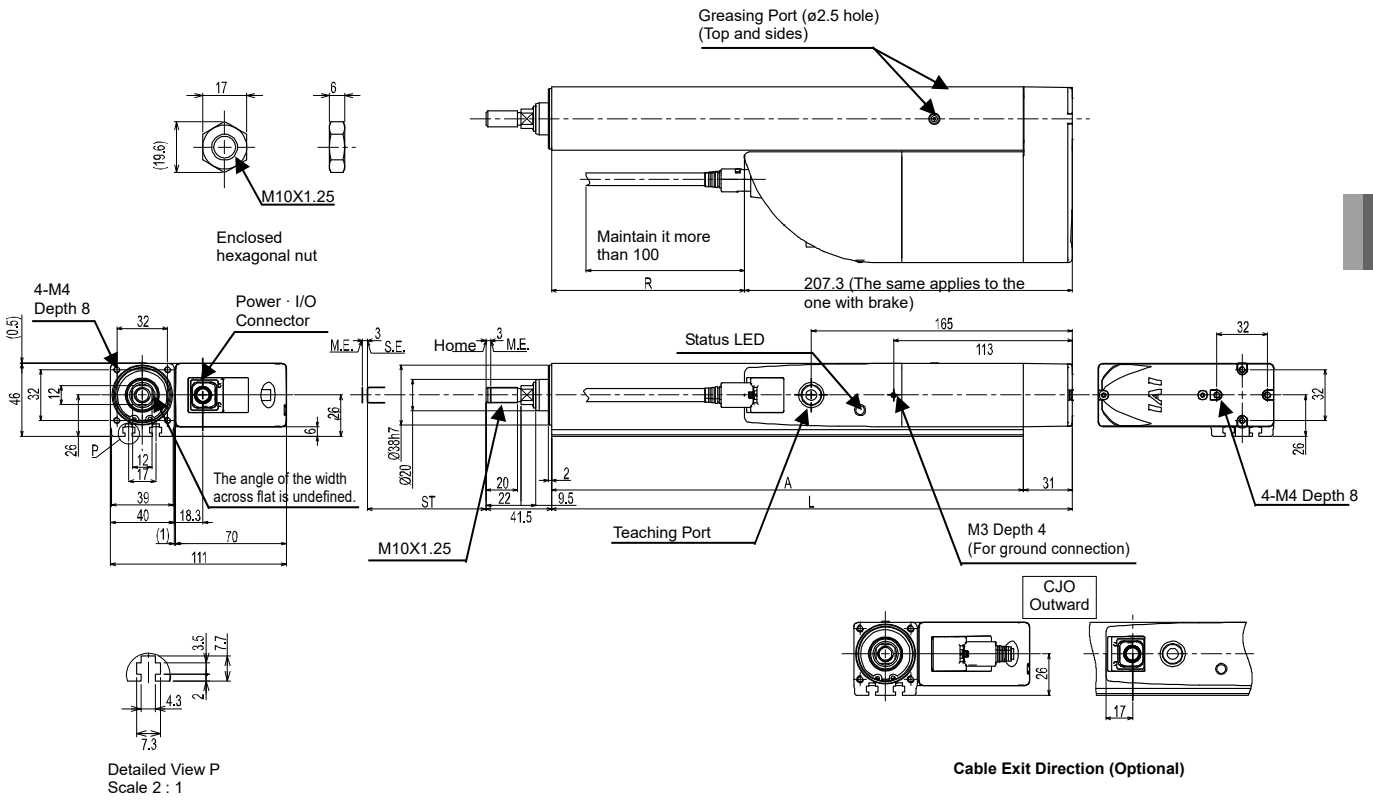

ST : Stroke  
M.E. : Mechanical End  
S.E. : Stroke End

Stroke	L	A	R	Mass [kg]	
				W/o Brake	With Brake
50	179	148	-28.3	1.6	1.7
100	229	198	21.7	1.8	1.9
150	279	248	71.7	2	2.1
200	329	298	121.7	2.2	2.3

(Note) When R dimension is negative, the end of the motor unit is located before the base end surface.

## 6.13 Standard Specification RCP6-RA6R Top Side-Mounted (Model: MT)

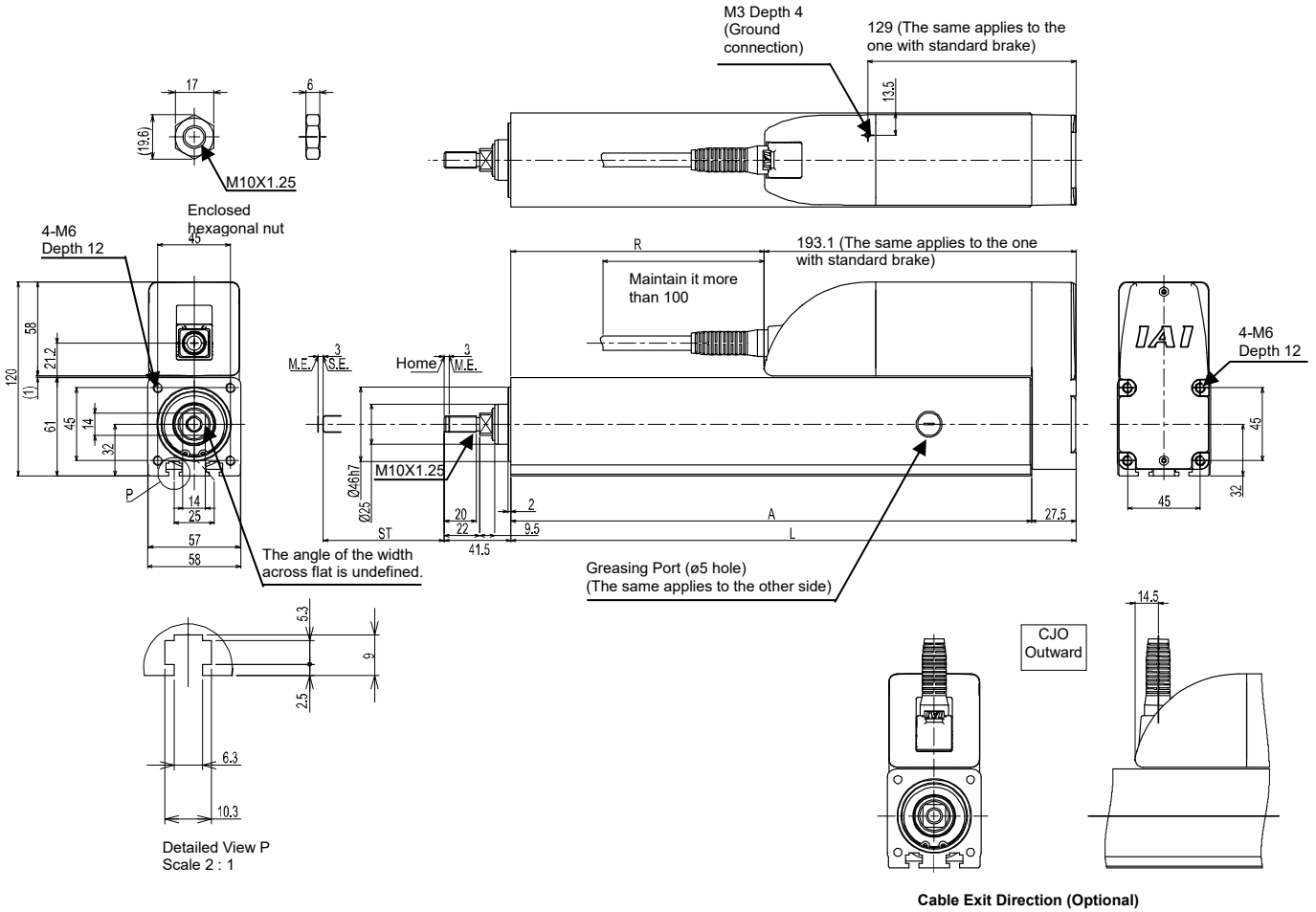

ST : Stroke  
M.E. : Mechanical End  
S.E. : Stroke End

Stroke	L	A	R	Mass [kg]	
				W/o Brake	With Brake
50	200	172.5	6.9	2.8	2.9
100	250	222.5	56.9	3.2	3.3
150	300	272.5	106.9	3.6	3.7
200	350	322.5	156.9	4.0	4.1
250	400	372.5	206.9	4.4	4.5
300	450	422.5	256.9	4.8	4.9

## 6.14 Standard Specification RCP6-RA6R Left Side-Mounted (Model: ML)

(Note) For Right Side-Mounted (model: MR), side-mounted motor will be on the right side in the drawing beneath.

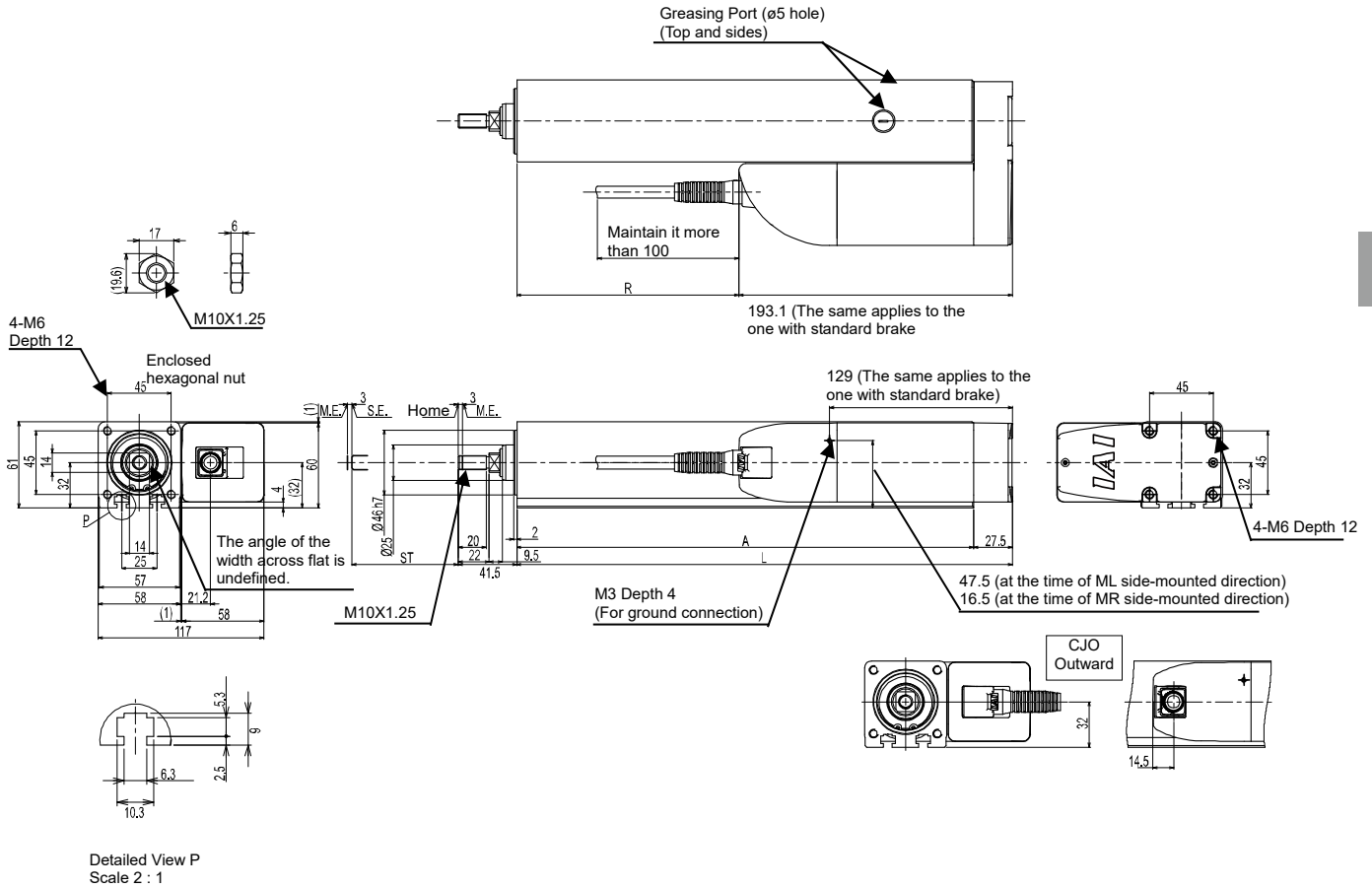

ST : Stroke  
M.E. : Mechanical End  
S.E. : Stroke End

Stroke	L	A	R	Mass [kg]	
				W/o Brake	With Brake
50	200	172.5	6.9	2.8	2.9
100	250	222.5	56.9	3.2	3.3
150	300	272.5	106.9	3.6	3.7
200	350	322.5	156.9	4.0	4.1
250	400	372.5	206.9	4.4	4.5
300	450	422.5	256.9	4.8	4.9

## 6.15 Built-in Controller Specification RCP6S-RA6R Top Side-Mounted (Model: MT)

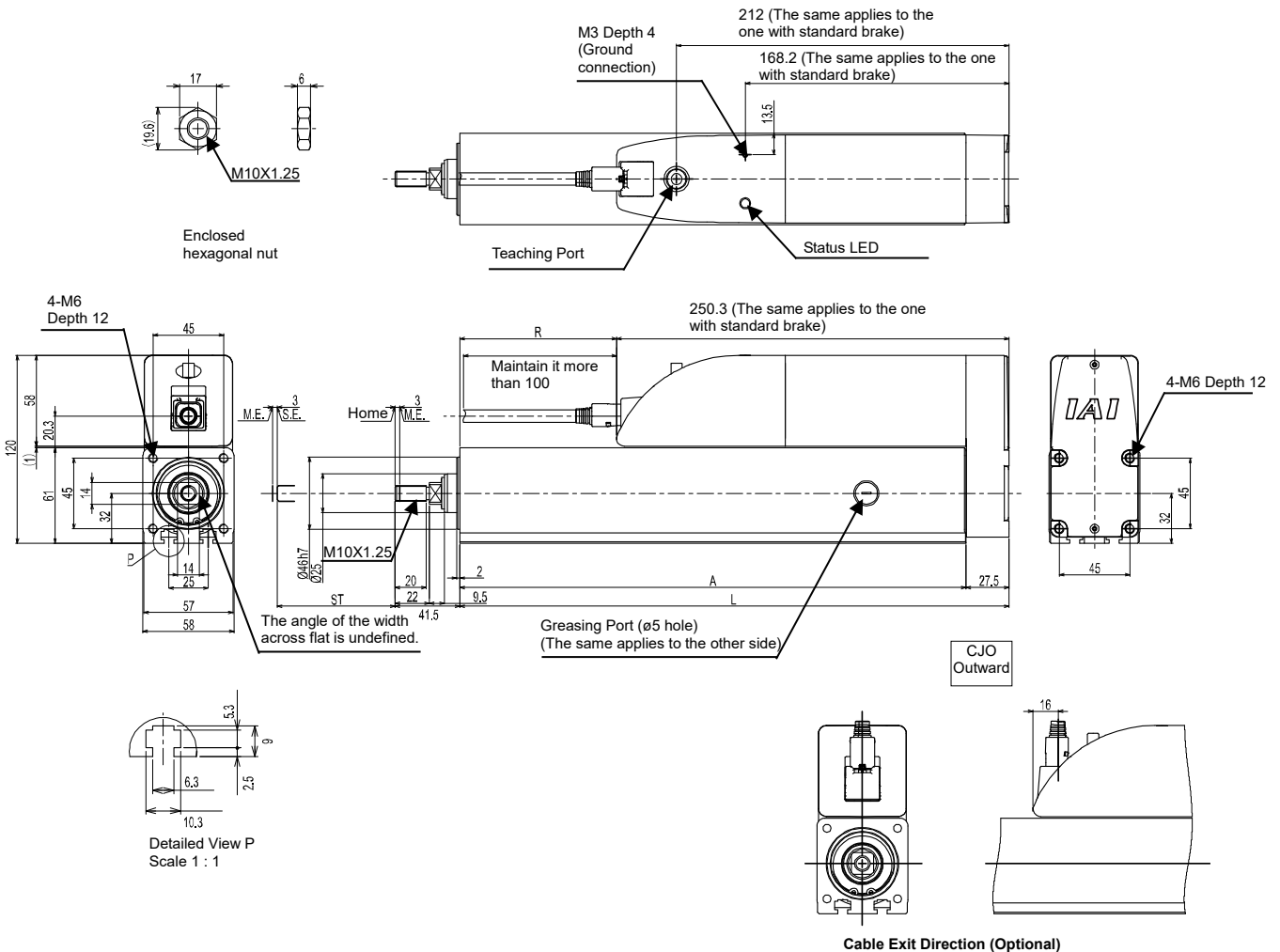

ST : Stroke  
M.E. : Mechanical End  
S.E. : Stroke End

Stroke	L	A	R	Mass [kg]	
				W/o Brake	With Brake
50	200	172.5	-50.3	2.9	3.0
100	250	222.5	-0.3	3.3	3.4
150	300	272.5	49.7	3.7	3.8
200	350	322.5	99.7	4.1	4.2
250	400	372.5	149.7	4.5	4.6
300	450	422.5	199.7	4.9	5.0

(Note) When R dimension is negative, the end of the motor unit is located before the base end surface.





## 6.17 Standard Specification RCP6-RA7R Top Side-Mounted (Model: MT)

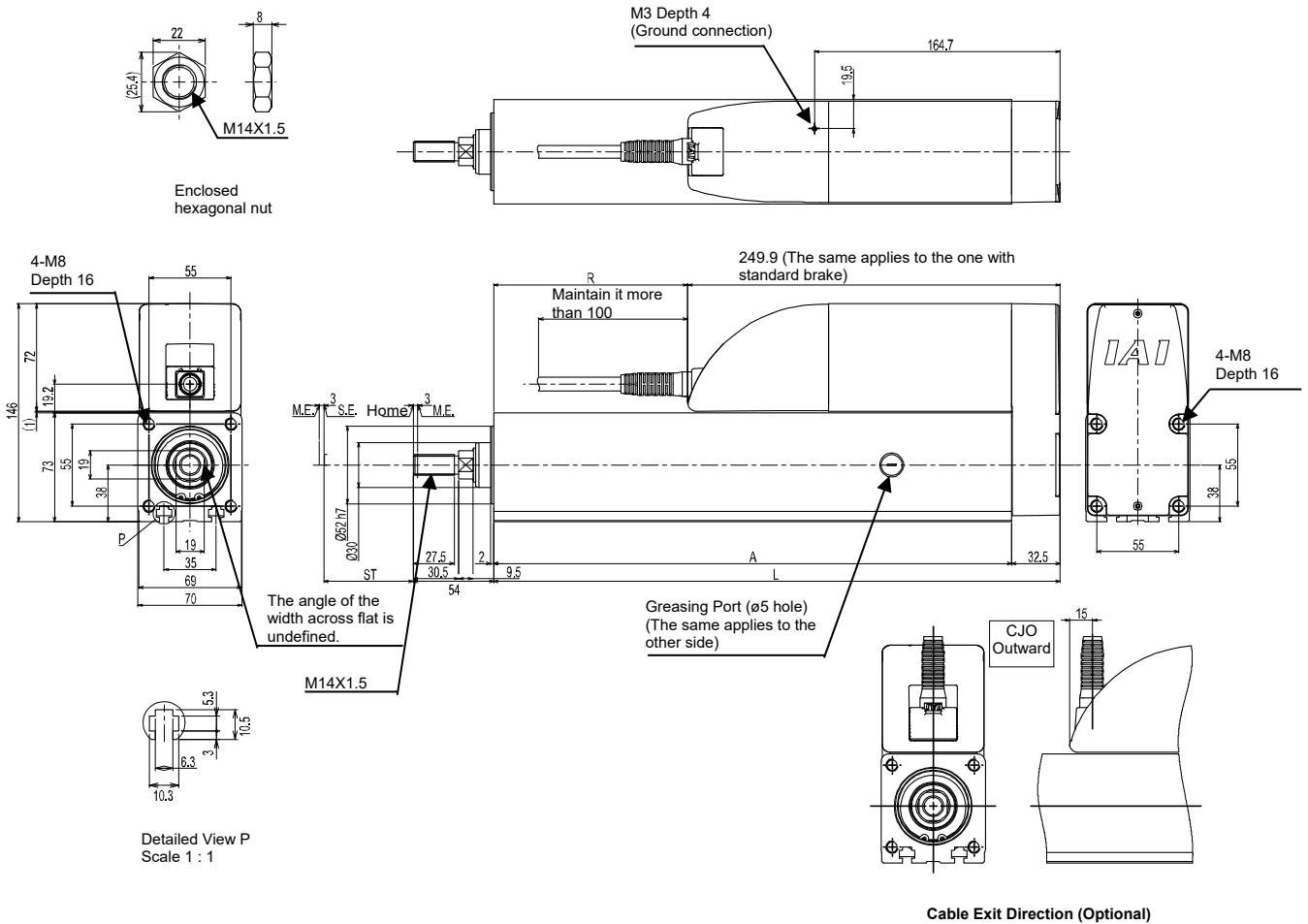

ST : Stroke  
M.E. : Mechanical End  
S.E. : Stroke End

Stroke	L	A	R	Mass [kg]	
				W/o Brake	With Brake
50	230	197.5	-19.9	5.1	5.2
100	280	247.5	30.1	5.7	5.8
150	330	297.5	80.1	6.3	6.4
200	380	347.5	130.1	6.9	7.0
250	430	397.5	180.1	7.5	7.6
300	480	447.5	230.1	8.1	8.2

(Note) When R dimension is negative, the end of the motor unit is located before the base end surface.

## 6.18 Standard Specification RCP6-RA7R Left Side-Mounted (Model: ML)

(Note) For Right Side-Mounted (model: MR), side-mounted motor will be on the right side in the drawing beneath.

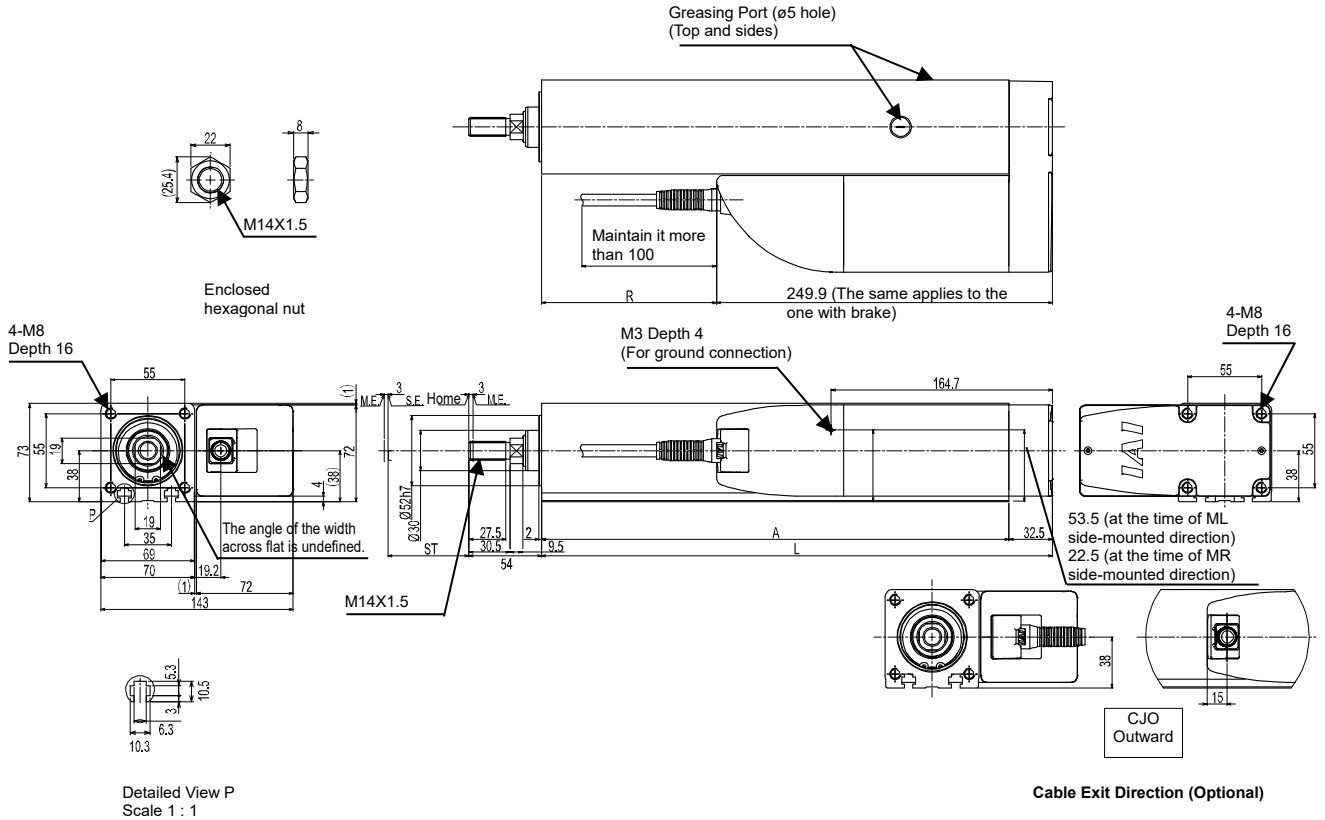

ST : Stroke  
M.E. : Mechanical End  
S.E. : Stroke End

Stroke	L	A	R	Mass [kg]	
				W/o Brake	With Brake
50	230	197.5	-19.9	5.1	5.2
100	280	247.5	30.1	5.7	5.8
150	330	297.5	80.1	6.3	6.4
200	380	347.5	130.1	6.9	7.0
250	430	397.5	180.1	7.5	7.6
300	480	447.5	230.1	8.1	8.2

(Note) When R dimension is negative, the end of the motor unit is located before the base end surface.

### 6.19 Built-in Controller Specification RCP6S-RA7R Top Side-Mounted (Model: MT)

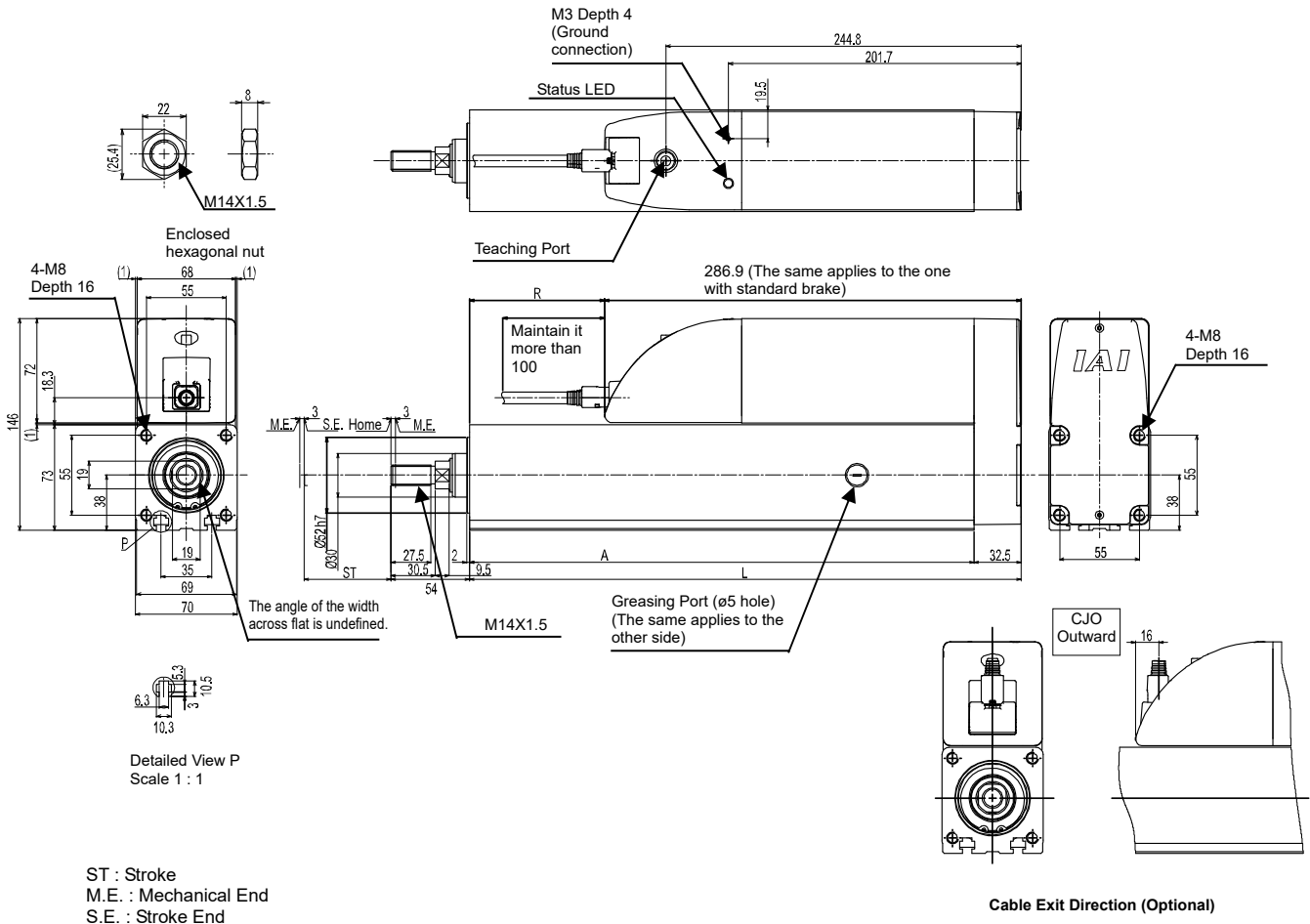

Stroke	L	A	R	Mass [kg]	
				W/o Brake	With Brake
50	230	197.5	-56.9	5.2	5.3
100	280	247.5	-6.9	5.8	5.9
150	330	297.5	43.1	6.4	6.5
200	380	347.5	93.1	7.0	7.1
250	430	397.5	143.1	7.6	7.7
300	480	447.5	193.1	8.1	8.2

(Note) When R dimension is negative, the end of the motor unit is located before the base end surface.

## 6.20 Built-in Controller Specification RCP6S-RA7R Left Side-Mounted (Model: ML)

(Note) For Right Side-Mounted (model: MR), side-mounted motor will be on the right side in the drawing beneath.

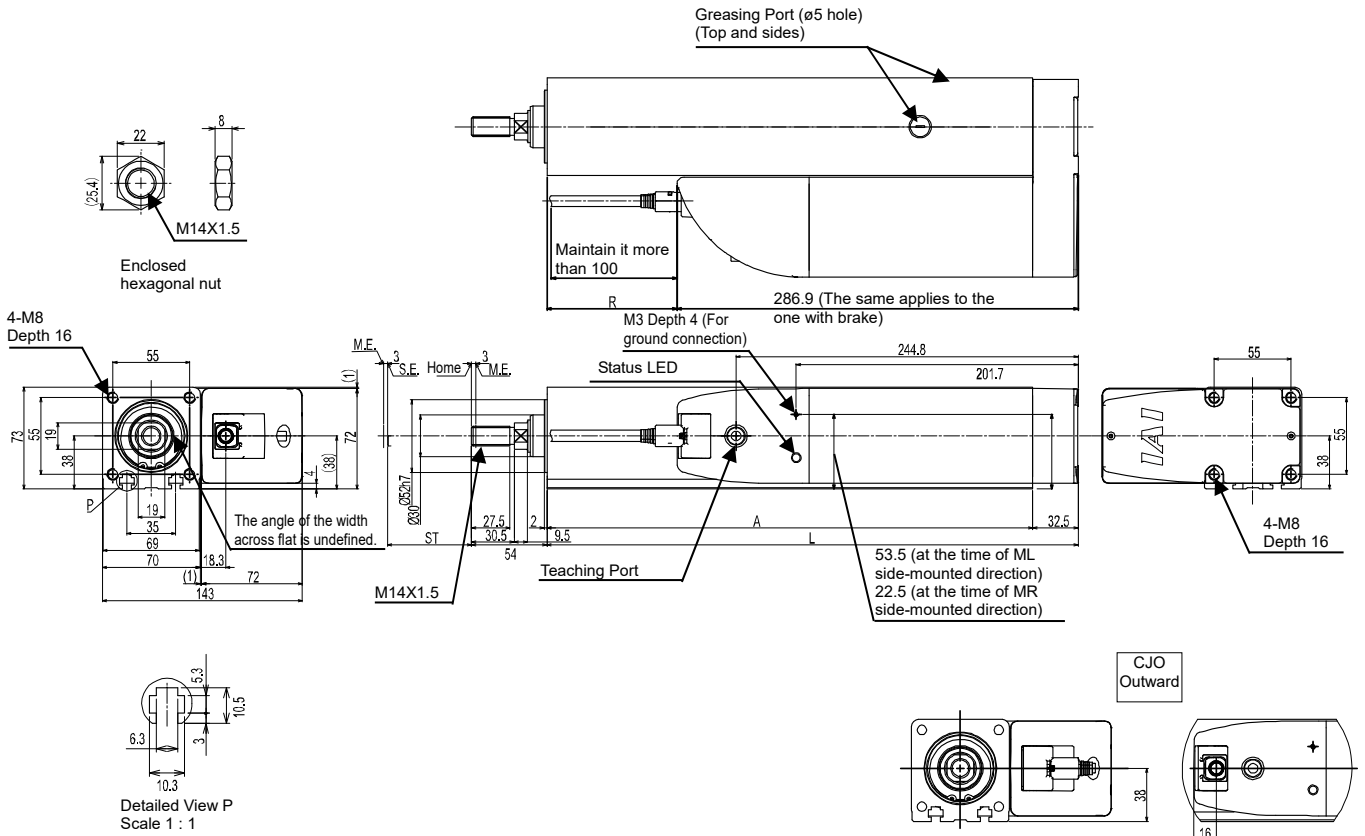

ST : Stroke  
M.E. : Mechanical End  
S.E. : Stroke End

Stroke	L	A	R	Mass [kg]	
				W/o Brake	With Brake
50	230	197.5	-56.9	5.2	5.3
100	280	247.5	-6.9	5.8	5.9
150	330	297.5	43.1	6.4	6.5
200	380	347.5	93.1	7.0	7.1
250	430	397.5	143.1	7.6	7.7
300	480	447.5	193.1	8.1	8.2

(Note) When R dimension is negative, the end of the motor unit is located before the base end surface.



## 6.22 Standard Specification RCP6-RA8R Left Side-Mounted (Model: ML)

(Note) For Right Side-Mounted (model: MR), side-mounted motor will be on the right side in the drawing beneath.

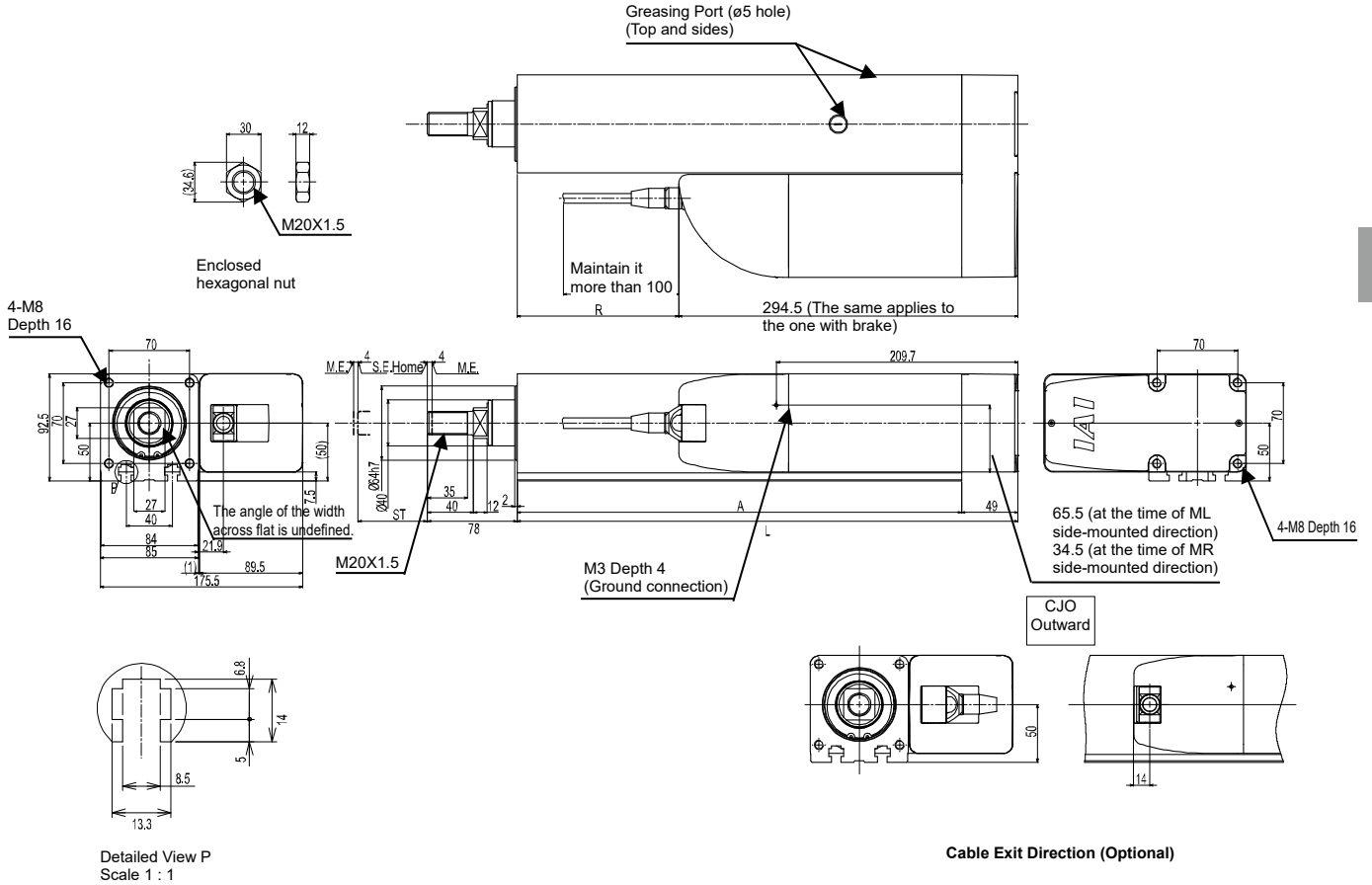

ST : Stroke  
M.E. : Mechanical End  
S.E. : Stroke End

Stroke	L	A	R	Mass [kg]	
				W/o Brake	With Brake
50	284.5	235.5	-10	9.0	9.2
100	334.5	285.5	40	9.9	10.1
150	384.5	335.5	90	10.8	11.0
200	434.5	385.5	140	11.7	11.9
250	484.5	435.5	190	12.6	12.8
300	534.5	485.5	240	13.5	13.7

(Note) When R dimension is negative, the end of the motor unit is located before the base end surface.

## 6.23 Built-in Controller Specification RCP6S-RA8R Top Side-Mounted (Model: MT)

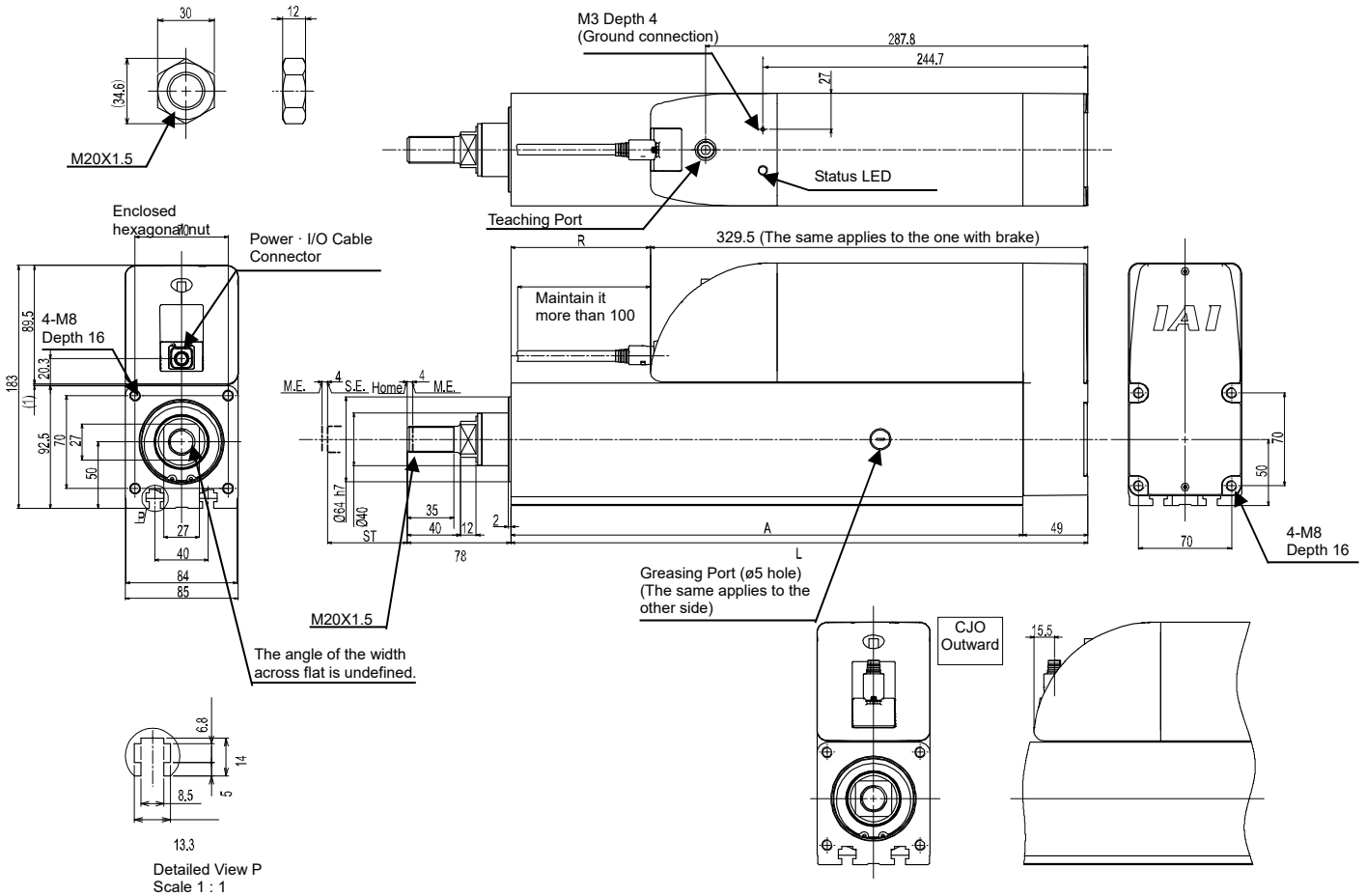

ST : Stroke  
M.E. : Mechanical End  
S.E. : Stroke End

Cable Exit Direction (Optional)

Stroke	L	A	R	Mass [kg]	
				W/o Brake	With Brake
50	284.5	235.5	-45	9.2	9.4
100	334.5	285.5	5	10.1	10.3
150	384.5	335.5	55	11.0	11.2
200	434.5	385.5	105	11.9	12.1
250	484.5	435.5	155	12.8	13.0
300	534.5	485.5	205	13.7	13.9

(Note) When R dimension is negative, the end of the motor unit is located before the base end surface.



## 6.24 Standard Specification RCP6S-RA8R Left Side-Mounted (Model: ML)

(Note) For Right Side-Mounted (model: MR), side-mounted motor will be on the right side in the drawing beneath.

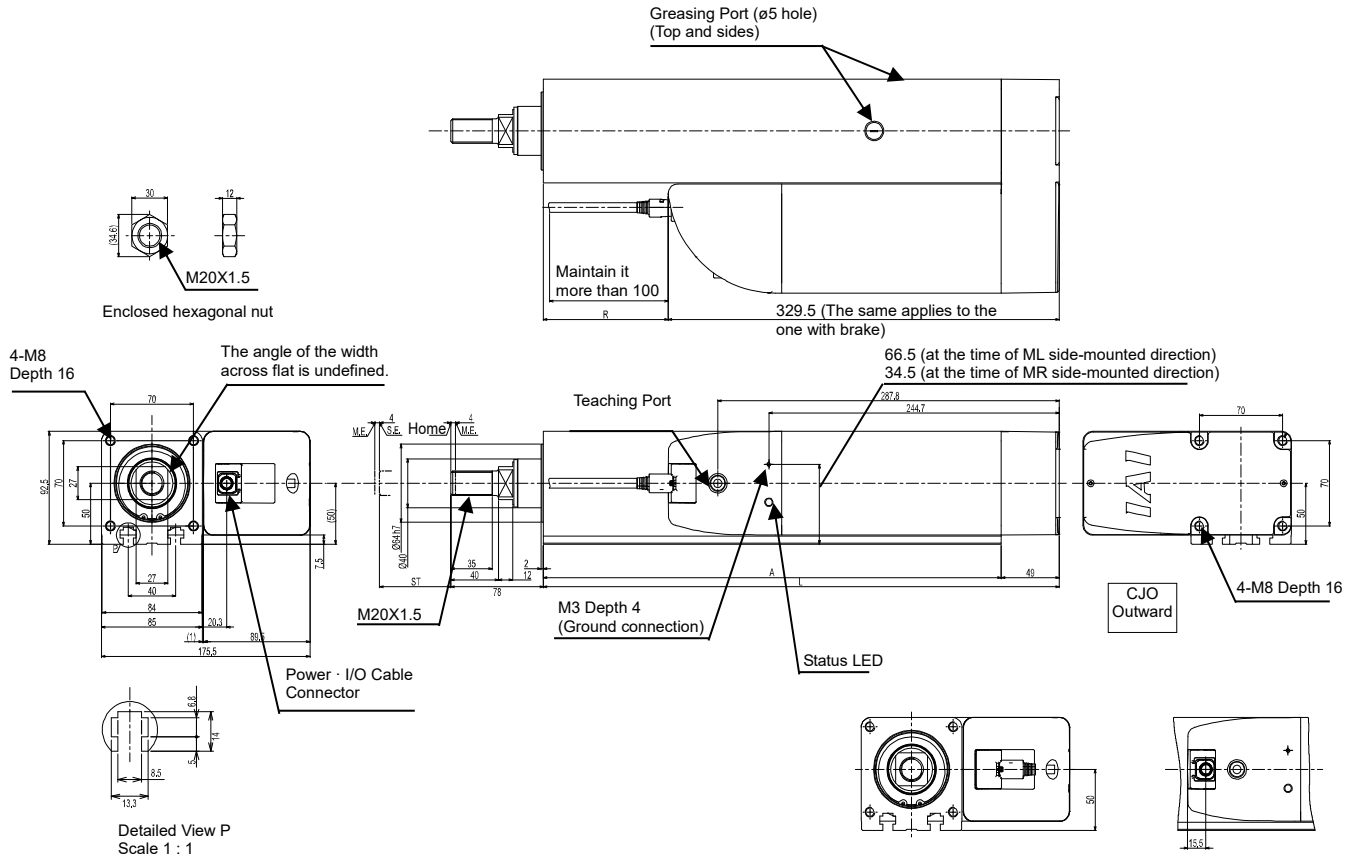

Cable Exit Direction (Optional)

ST : Stroke  
M.E. : Mechanical End  
S.E. : Stroke End

Stroke	L	A	R	Mass [kg]	
				W/o Brake	With Brake
50	284.5	235.5	-45	9.2	9.4
100	334.5	285.5	5	10.1	10.3
150	384.5	335.5	55	11.0	11.2
200	434.5	385.5	105	11.9	12.1
250	484.5	435.5	155	12.8	13.0
300	534.5	485.5	205	13.7	13.9

(Note) When R dimension is negative, the end of the motor unit is located before the base end surface.

## 7. Life

### 7.1 RA4C, RA4R, RA6C, RA6R, RA7C, RA7R

The life is assumed under condition of operation with maximum transported mass and maximum acceleration/deceleration, and it is 5,000km (reference).

### 7.2 RA8C, RA8R

The life in the standard horizontal orientation is assumed under condition of operation with maximum transported mass and maximum acceleration/deceleration, and it is 5,000km (reference).

The life in the vertical orientation may change depending on the transported mass. The graph below shows the relation of transported mass and life.

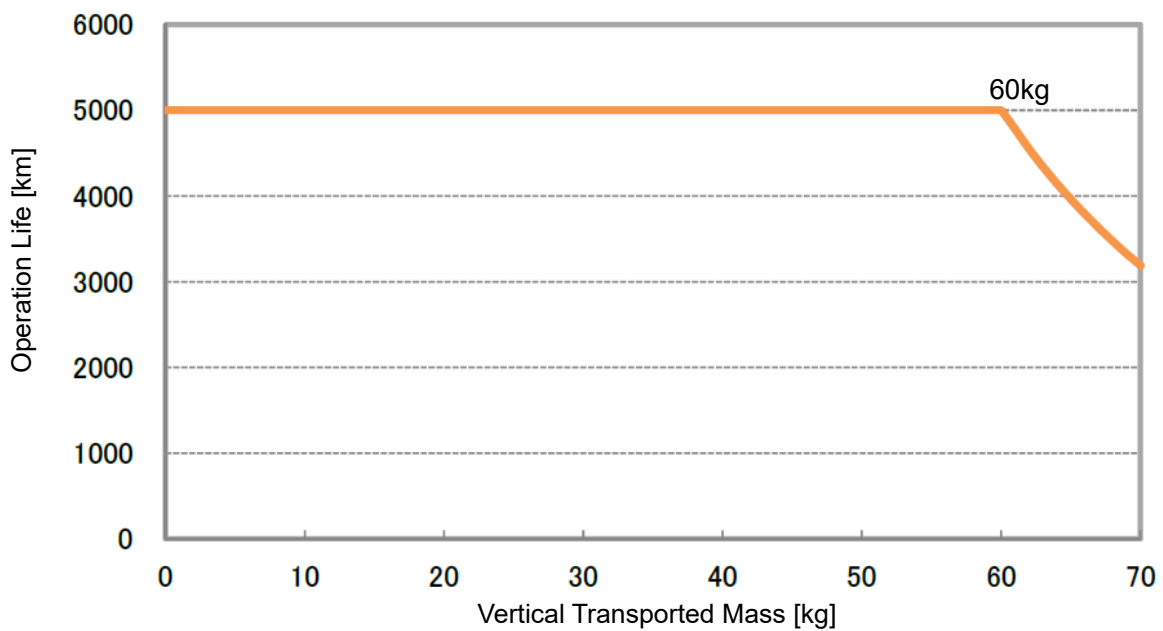

## 8. Warranty

### 8.1 Warranty Period

One of the following periods, whichever is shorter:

- 18 months after shipment from IAI
- 12 months after delivery to the specified location
- 2,500 hours of operation

### 8.2 Scope of the Warranty

Our products are covered by warranty when all of the following conditions are met. Faulty products covered by warranty will be replaced or repaired free of charge:

- (1) The breakdown or problem in question pertains to our product as delivered by us or our authorized dealer.
- (2) The breakdown or problem in question occurred during the warranty period.
- (3) The breakdown or problem in question occurred while the product was in use for an appropriate purpose under the conditions and environment of use specified in the instruction manual and catalog.
- (4) The breakdown of problem in question was caused by a specification defect or problem, or by a quality issue with our product.

Note that breakdowns due to any of the following reasons are excluded from the scope of warranty:

- [1] Anything other than our product
- [2] Modification or repair performed by a party other than us (unless we have approved such modification or repair)
- [3] Anything that could not be easily predicted with the level of science and technology available at the time of shipment from our company
- [4] A natural disaster, man-made disaster, incident or accident for which we are not liable
- [5] Natural fading of paint or other symptoms of aging
- [6] Wear, depletion or other expected result of use
- [7] Operation noise, vibration or other subjective sensation not affecting function or maintenance

Note that the warranty only covers our product as delivered and that any secondary loss arising from a breakdown of our product is excluded from the scope of warranty.

### 8.3 Honoring the Warranty

As a rule, the product must be brought to us for repair under warranty.

## 8.4 Limited Liability

- (1) We shall assume no liability for any special damage, consequential loss or passive loss such as a loss of expected profit arising from or in connection with our product.
- (2) We shall not be liable for any program or control method created by the customer to operate our product or for the result of such program or control method.

## 8.5 Conditions of Conformance with Applicable Standards/Regulations, Etc., and Applications

- (1) If our product is combined with another product or any system, device, etc., used by the customer, the customer must first check the applicable standards, regulations and/or rules. The customer is also responsible for confirming that such combination with our product conforms to the applicable standards, etc. In such a case we will not be liable for the conformance of our product with the applicable standards, etc.
- (2) Our product is for general industrial use. It is not intended or designed for the applications specified below, which require a high level of safety. Accordingly, as a rule our product cannot be used in these applications. Contact us if you must use our product for any of these applications:
  - 1) Medical equipment used to maintain, control or otherwise affect human life or physical health.
  - 2) Mechanisms and machinery designed for the purpose of moving or transporting people (For vehicle, railway facility or air navigation facility)
  - 3) Important safety parts of machinery (Safety device, etc.)
  - 4) Equipment used to handle cultural assets, art or other irreplaceable items
- (3) Contact us at the earliest opportunity if our product is to be used in any condition or environment that differs from what is specified in the catalog or instruction manual.

## 8.6 Other Items Excluded from Warranty

The price of the product delivered to you does not include expenses associated with programming, the dispatch of engineers, etc. Accordingly, a separate fee will be charged in the following cases even during the warranty period:

- [1] Guidance for installation/adjustment and witnessing of test operation
- [2] Maintenance and inspection
- [3] Technical guidance and education on operating/wiring methods, etc.
- [4] Technical guidance and education on programming and other items related to programs

## Change History

Revision Date	Description of Revision
January 2016	First edition
April 2016	Edition 1B <ul style="list-style-type: none"> <li>• Pg. 17 Added square T-nut to the list of parts</li> <li>• Pg. 21 Corrected "Number of Encoder Pulse" to "800"</li> <li>• Pg. 61 Corrected misdescription (maximum stroke of RA4, from 12 to -12)</li> <li>• Pg. 63, 72 Deleted tightening torque for the case when aluminum is used for the bolt seating surface</li> <li>• Pg. 71 Changed non-mountable stroke of front flange (option)</li> <li>• Pg. 81, 82 Added description for greasing and cleaning the rod sliding surface</li> <li>• Pg. 84 Changed belt manufacturer for RA4R and RA7R</li> </ul>
May 2016	Edition 1C <ul style="list-style-type: none"> <li>• Pg. 89 Added precautions about static electricity during motor replacement</li> </ul>
Jun 2016	Second edition <ul style="list-style-type: none"> <li>• Added specifications about when high-output setting is ineffective</li> <li>• Pg. 54 Changed graphs about duty ratio</li> </ul>
July 2016	Edition 2B <ul style="list-style-type: none"> <li>• Pg. 48 to 51 Added scale to the graphs</li> </ul>
Oct 2016	Edition 2C <ul style="list-style-type: none"> <li>• Pg. 96, 97, 105, 106, 107, 108 Added drawings of RA7R and RA8R</li> </ul>
Mar 2017	Edition 2D <ul style="list-style-type: none"> <li>• Pg. 88 Added a cautionary note against binding cables together in coils, etc.</li> </ul>
April 2017	Edition 2E <ul style="list-style-type: none"> <li>• Pg. 79 Corrected Tightening Torque table RA6, RA7 → RA6 RA8 → RA7, RA8</li> </ul>
May 2017	Edition 2F <ul style="list-style-type: none"> <li>• Pg. 86 Corrected errata "use for operation" -&gt; "movable use", etc.</li> </ul>
June 2017	Edition 2G <ul style="list-style-type: none"> <li>• Pg. 19 Added RCM-P6PC to the compatible controllers</li> </ul>
August 2017	Edition 2H <ul style="list-style-type: none"> <li>• Pg. 86 Added information for when CB-CFA3-MPA□□□(-RB) is 3m or less, or over 3m</li> </ul>

## Change History

Revision Date	Description of Revision
September 2017	Edition 2I • Pg. 93                      Added instructions for greasing from one greasing port
July 2018	Edition 2J • Added description for RCON





## ***IAI Corporation***

Head Office: 577-1 Obane Shimizu-ku Shizuoka City Shizuoka 424-0103, Japan  
TEL +81-54-364-5105 FAX +81-54-364-2589  
website: [www.iai-robot.co.jp/](http://www.iai-robot.co.jp/)

Technical Support available in USA, Europe and China

## ***IAI America, Inc.***

US Headquarters: 2690 W. 237th Street, Torrance, CA 90505  
TEL (310) 891-6015 FAX (310) 891-0815  
Chicago Office: 110 East State Parkway, Schaumburg, IL 60173  
TEL (847) 908-1400 FAX (847) 908-1399  
Atlanta Office: 1220 Kennestone Circle, Suite 108, Marietta, GA 30066  
TEL (678) 354-9470 FAX (678) 354-9471  
website: [www.intelligentactuator.com](http://www.intelligentactuator.com)

## ***IAI Industrieroboter GmbH***

Ober der Röth 4, D-65824 Schwalbach am Taunus, Germany  
TEL 06196-88950 FAX 06196-889524

## ***IAI (Shanghai) Co., Ltd.***

SHANGHAI JIAHUA BUSINESS CENTER A8-303, 808, Hongqiao Rd. Shanghai 200030, China  
TEL 021-6448-4753 FAX 021-6448-3992  
website: [www.iai-robot.com](http://www.iai-robot.com)

## ***IAI Robot (Thailand) Co., Ltd.***

825, PhairojKijja Tower 7th Floor, Bangna-Trad RD., Bangna, Bangkok 10260, Thailand  
TEL +66-2-361-4458 FAX +66-2-361-4456