

## 1078T/78CT SERIES TERMINAL MAGNETIC CONTACTS

### 3/4" and 1" Steel Door Contacts

Model numbers:  
R1078T, 1078TW, R1078CT, 1078CTW

Optional 1840  
Rare Earth Magnet



- **New terminal design for easy connection**
- **Designed specifically for use in steel doors**
- **Special ribbed sides allow for easy installation**
- **Rugged unibody construction for maximum durability and reliability**
- **Regular and Wide Gap**
- **Rare Earth Magnet designed for steel doors with top channel available**

The Sentrol 1078T Series Steel Door Terminal Contacts are designed specifically for use in the steel doors commonly found in commercial building applications. The unique housing design features a rugged unibody construction with flexible ribbed sides for quick, secure installation without gluing. The magnet housing isolates the magnet from the surrounding steel for maximum gap distances, both make and break.

The terminal connection adds to the ease of installation. Simply strip the wire, insert it into the terminal block and tighten. The terminal accepts any wire size from 14 to 22 gauge, and has a unique one piece design for added strength.

An optional Rare Earth Magnet is available. It is designed for use in metal entry/exit doors with a channel in the top of the door. The magnet eliminates the need to cut a mounting hole in the door channel. The flexible magnet housing can be compressed to accommodate a variety of channel widths for quick, easy installation. Adhesive is recommended.

# Sentrol 1078T/78CT Series

## Architects and Engineering Specifications

The contact contains a hermetically sealed magnetic reed switch. The reed shall be potted in the contact housing with a polyurethane based compound. Contact and magnet housing shall snap-lock into a 3/4" or 1" dia. hole. Housings shall be molded of flame retardant ABS plastic. Color of housings shall be white, grey or mahogany brown. The magnet shall be made of Alnico V. Rare Earth Magnet shall be made of neodymium iron boron.

## Designed for Use in Steel Doors

Snap-lock insulation bushing for tight fit and maximum gap in steel.

## Rugged Unibody Construction for Maximum Durability and Reliability

Both contact and magnet plastic housings are constructed of one piece of thick-walled ABS plastic for maximum strength and durability.

## Specifications:

**Form A: (R)1078T, 1078TW, (R)1078CT, 1078CTW**

Voltage ..... 100 V AC/DC max  
 Current ..... 0.5 A max  
 Power ..... 7.5 W max

**(R)1078T, 1078TW**

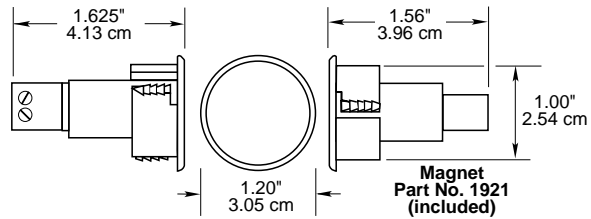

**(R)1078CT, 1078CTW**

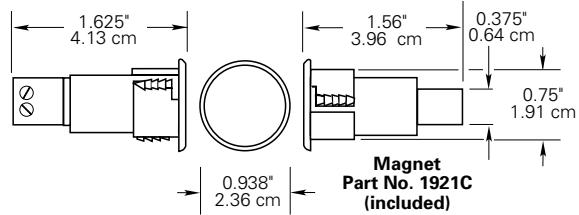

## Rare Earth Magnet

(R) prefix indicates Rare Earth Magnet

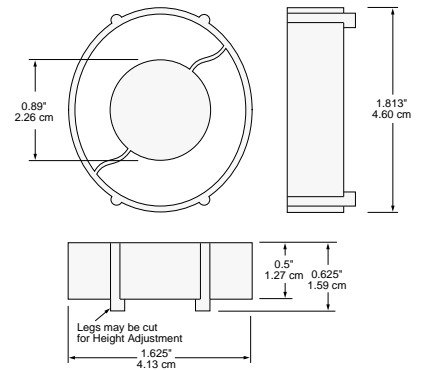

## Ordering Information

Model Number	Dia.	Loop Type	Elect. Config.	Hole Required		Gap Distance*		
				Contact	Magnet	Wood*	Steel*	Rare Earth
(R)1078T	1"	Closed	N.O.	1" x 1.625"	1" x 1.56"	7/8"	1/2"	5/8"
1078TW	1"	Closed	N.O.	1" x 1.625"	1" x 1.56"	1 5/8"	1"	
(R)1078CT	3/4"	Closed	N.O.	.75" x 1.625"	.75" x 1.56"	7/8"	3/8"	5/8"
1078CTW	3/4"	Closed	N.O.	.75" x 1.625"	.75" x 1.56"	1 5/8"	3/4"	

\* Gap distances are nominal make distance +/- 20%.

