

FAIRCHILD T5200 SERIES ELECTRO-PNEUMATIC TRANSDUCER

Installation, Operation and Maintenance Instructions

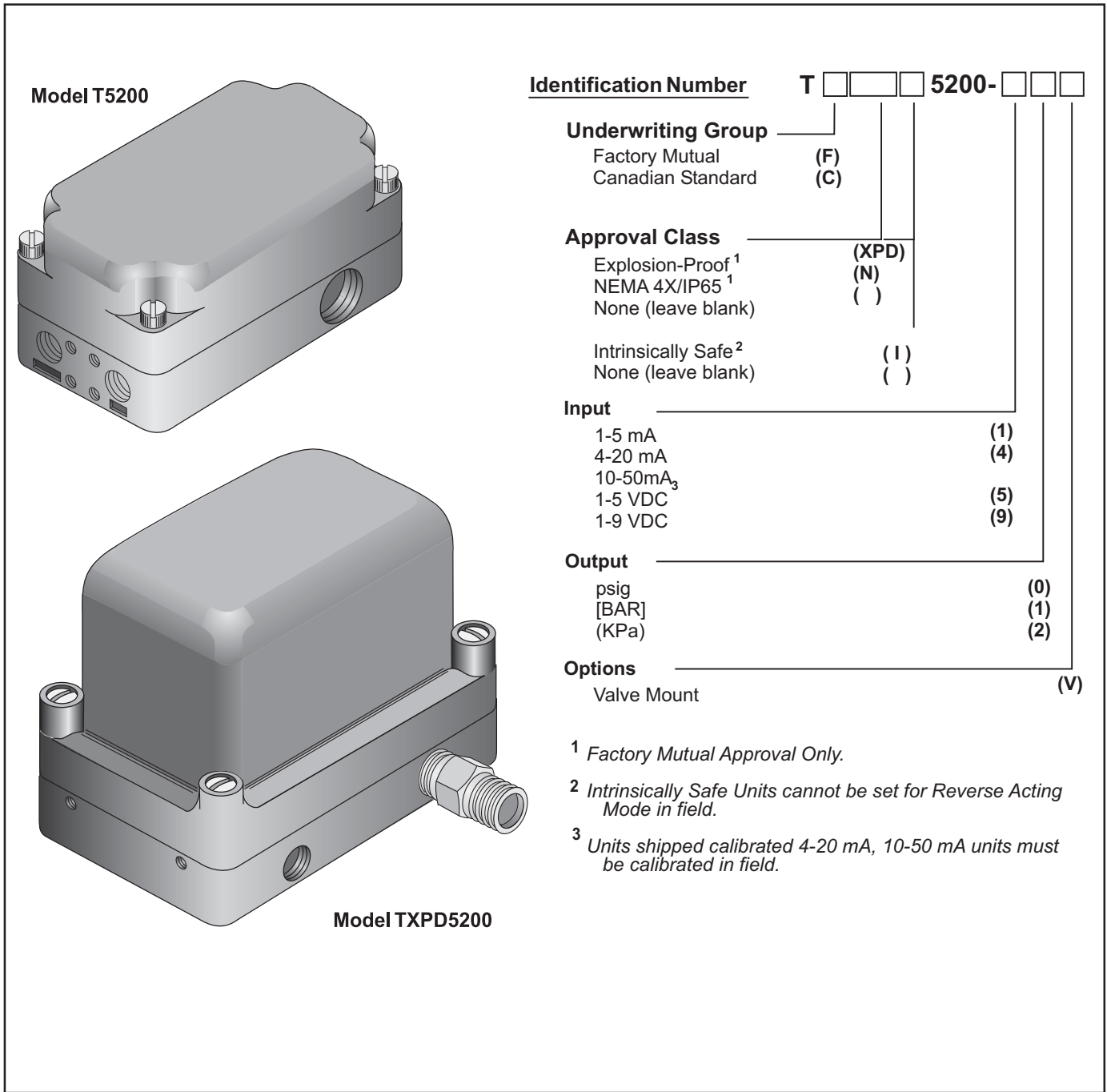

Figure 1. Model T5200 Series Transducer Identification Number System.

GENERAL INFORMATION

The Model T5200 Series Electro-Pneumatic Transducer converts a DC current or voltage input signal to a directly proportional pneumatic output.

SPECIFICATIONS

Functional Specifications													
Output Range	3-15 psig [0.2-1.0 BAR] (20-100 kPa)												
Supply Pressure	20 ± 2 psig [1.5 ± 0.15 BAR] (150 ± 15 kPa)												
Air Consumption (SCFM)	0.16 (0.27 m ³ /HR) Maximum												
Output Capacity (SCFM)	0.15 (0.26 m ³ /HR) Maximum												
Impedance/ Input Signal	<table border="1"> <thead> <tr> <th>Range</th> <th>OHMS (nominal)</th> </tr> </thead> <tbody> <tr> <td>1-5 mA</td> <td>2000</td> </tr> <tr> <td>4-20 mA</td> <td>120¹</td> </tr> <tr> <td>10-50 mA</td> <td>50¹</td> </tr> <tr> <td>1-9 VDC</td> <td>2550</td> </tr> <tr> <td>1-5 VDC</td> <td>375</td> </tr> </tbody> </table>	Range	OHMS (nominal)	1-5 mA	2000	4-20 mA	120 ¹	10-50 mA	50 ¹	1-9 VDC	2550	1-5 VDC	375
Range	OHMS (nominal)												
1-5 mA	2000												
4-20 mA	120 ¹												
10-50 mA	50 ¹												
1-9 VDC	2550												
1-5 VDC	375												
Performance Specifications													
Terminal Based Linearity	±0.50% Full Scale												
Independent Linearity	±0.25% Full Scale												
Hysteresis & Repeatability	within 0.1% Full Scale												
Supply Pressure Effect	18-22 psig, [1.2-1.55 BAR], (120-155 kPa) ±0.3% of span for a 1 psig, [0.1 BAR], (10 kPa) supply change.												
Shock and Vibration Effect	Negligible up to 2 g's between 5 Hz and 200 Hz												
Ambient Temperature	-40° F to +150° F (-40° C to +65.5° C)												
Temperature Coefficient	Less than 1% of Span / 50° F (27.7° C)												
Frequency Responce	-3 db @ 20 Hz (unloaded)												
RFI/EMI Effect	EMC Directive 89/336/EBC European NORM EN 61326												
Materials of Construction	Body and Housing Aluminum Ball and Orifice Sapphire Nozzle Stainless Steel PC Board Fiberglass												

¹ Add 332 OHMS for CSA.

HAZARDOUS AREA CLASSIFICATION

FM (Factory Mutual) Approvals:

Explosion-Proof:

(TFXPD5200)
Class I, Division 1, Groups B, C, and D;
Class II, Division 1, Groups E, F, and G;
Maximum Ambient 65° C;
NEMA 3R Enclosure. **(Upright Position Only)**

(TFXPD15200)
Class I, Division 1, Groups A, B, C, and D;
Class II, Division 1, Groups E, F, and G;
Class III, Division 1, Fibers;
Maximum Ambient 65° C.

(TFN5200)
NEMA 4X Enclosure.

Intrinsically Safe:

(TFI5200)
Class I, Division 1, Groups A, B, C, and D;
Class II, Division 1, Groups E, F, and G;
Class III, Division 1, Fibers;
NEMA 3R Enclosure. **(Upright Position Only)**

Entity Parameters					
Voc ¹	=	40 VDC	Ca ³	=	0 μF
Isc ²	=	125 mA	La ⁴	=	0 mH
¹ Voc = Open Circuit Voltage		³ Ca = External Capacitance			
² Isc = Short Circuit Current		⁴ La = External Inductance			

CSA (Canadian Standards Association) Approvals:

Intrinsically Safe:

(TCI5200)
Class I, Division 1, Groups A, B, C, and D;
Class II, Division 1, Groups E, F, and G;
Type 3 Enclosure;
Rated 1-5 mA, 4-20 mA, 10-50 mA, 1-5 VDC, and 1-9 VDC;
Temperature Code T4A.

Approvals are valid when connected through a Shunt Zener Diode Safety Barrier meeting the following parametric requirements:
Rated: 28V Max. 300 Ohm Min.



INSTALLATION

The Model T5200 can be mounted directly onto a flat surface using the two 10-32 tapped mounting holes in the base of the housing (except "V" option). For more information, see Figure 2. "T5200 Outline Dimensions" below.

An Optional Mounting Kit 14596 is available when installing the unit on a 2" pipe. For more information, see Figure 4. on page 4.

The Model T5200 can be Panel Mounted using the mounting bracket supplied in Mounting Kit EA-15268. For more information, see Figure 3. on page 3.

NOTE: To maintain NEMA 3R Rating, for outdoor use, mount the T5200 in an upright position. For more information, see Figure 4. "Mounting Kit 14596" on page 4.

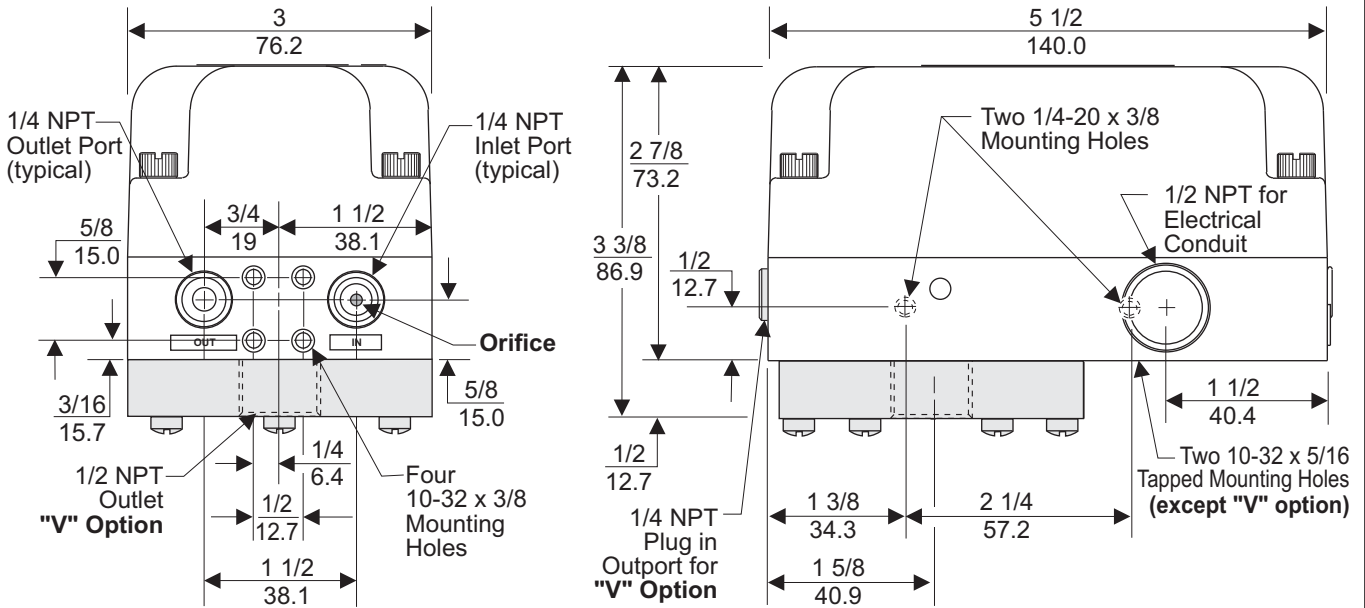

Figure 2. T5200 Outline Dimensions.

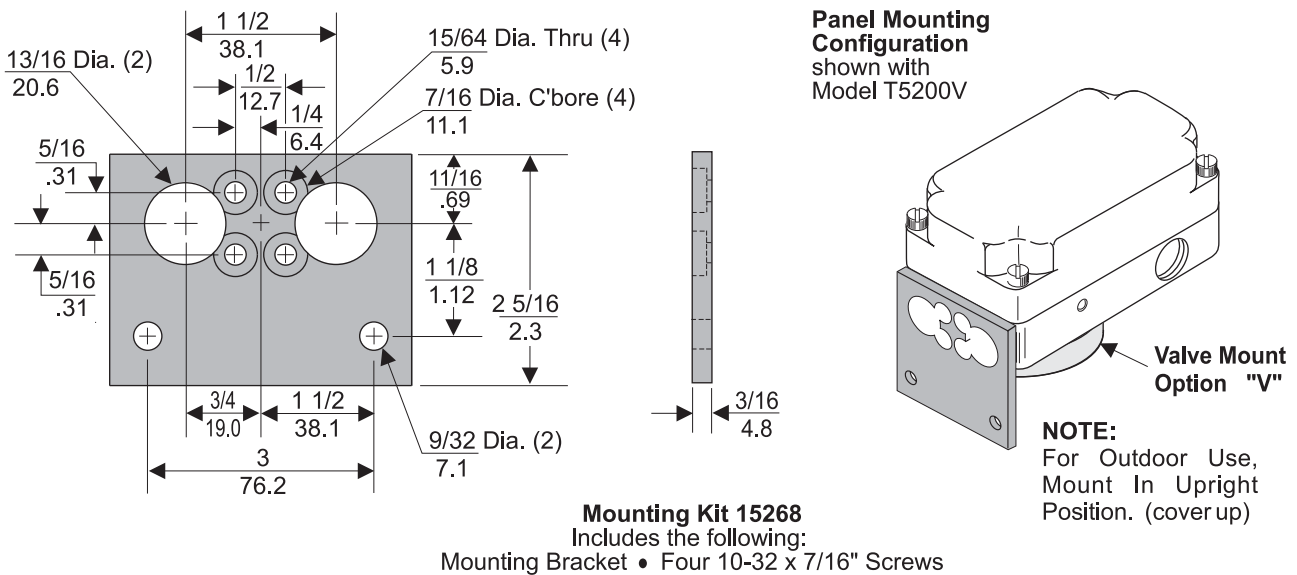
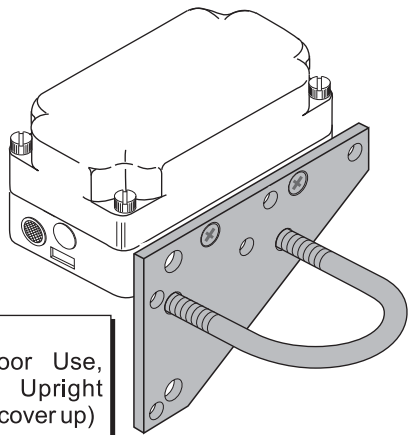

Figure 3. Mounting Kit 15268. (Sold Separately)

Installation (continued)

2" Pipe Mounting Configuration
shown with
Model T5200



NOTE:
For Outdoor Use,
Mount In Upright
Position. (cover up)

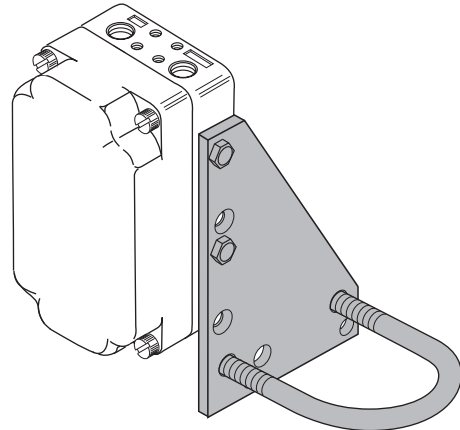

NOTE:
If Not Mounted In An
Upright Position, Zero &
Span Adjustments Must
Be Re-Calibrated For
Proper Output Range.

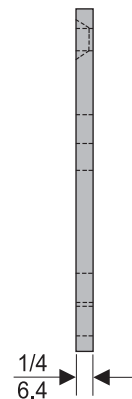
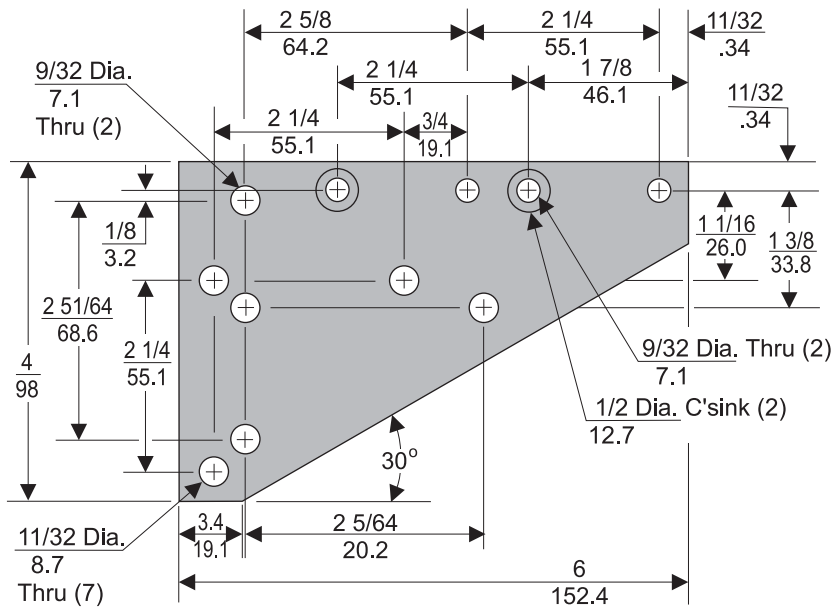
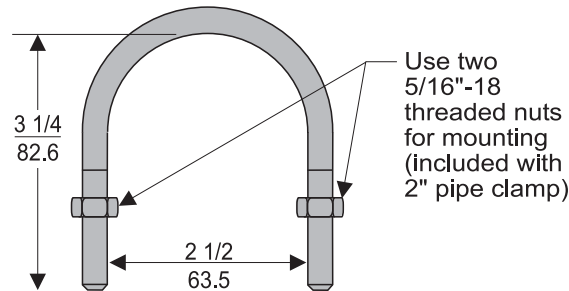

Mounting Kit 14596
Includes the following:
Mounting Bracket • Two Lockwashers
2" Pipe Clamp • Two 1/4-20 x 5/8" Bolts
Two 1/4-20 x 1/2" Screws

Figure 4. Optional Mounting Kit 14596. (Sold Separately)

INSTALLATION

The Model TXPD5200 can be mounted directly onto a flat surface using the four 1/4-20 x 7/16 tapped mounting holes in the base of the housing (except "V" option). For more information, see Figure 5. "TXPD5200 Outline Dimensions" below.

Mounting Kit 14140 is available for Panel or 2" Pipe Mounting. For more information, see Figure 6. on page 5.

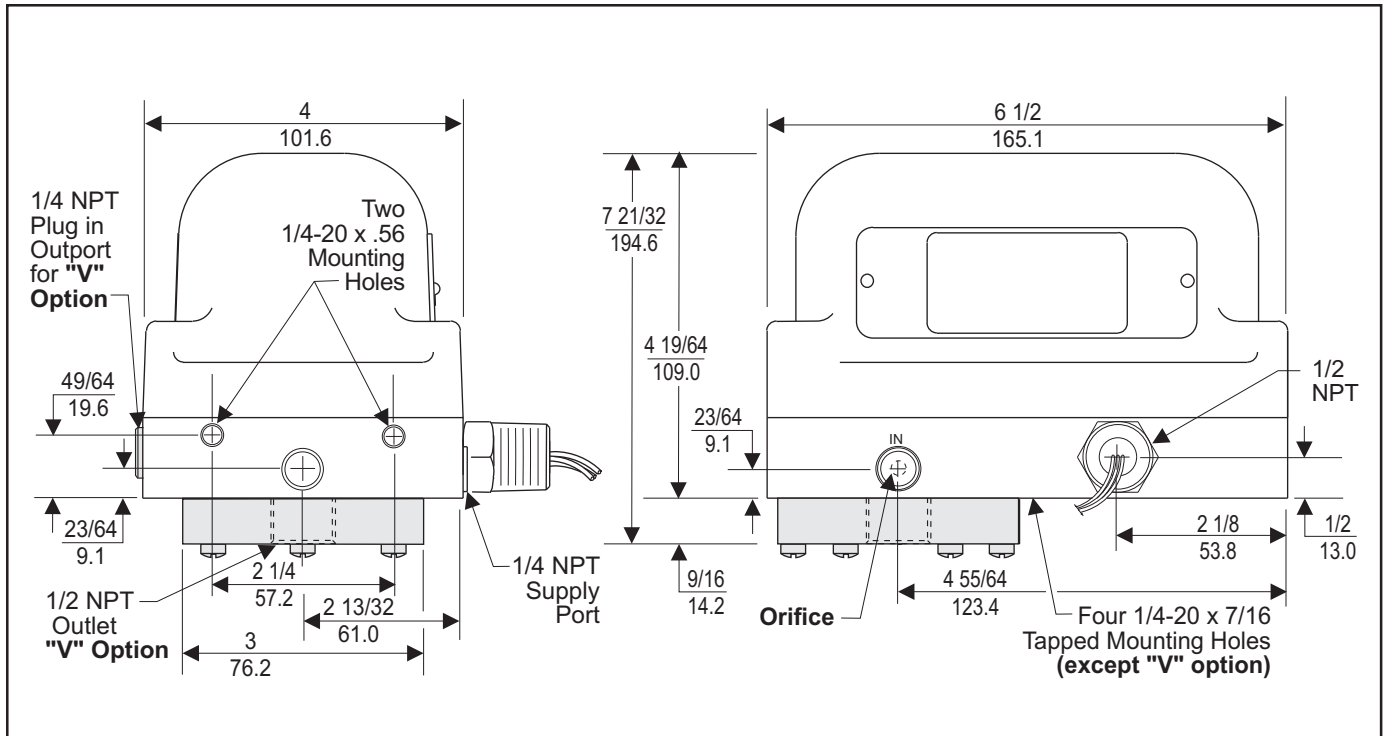

Figure 5. TXPD5200 Outline Dimensions.

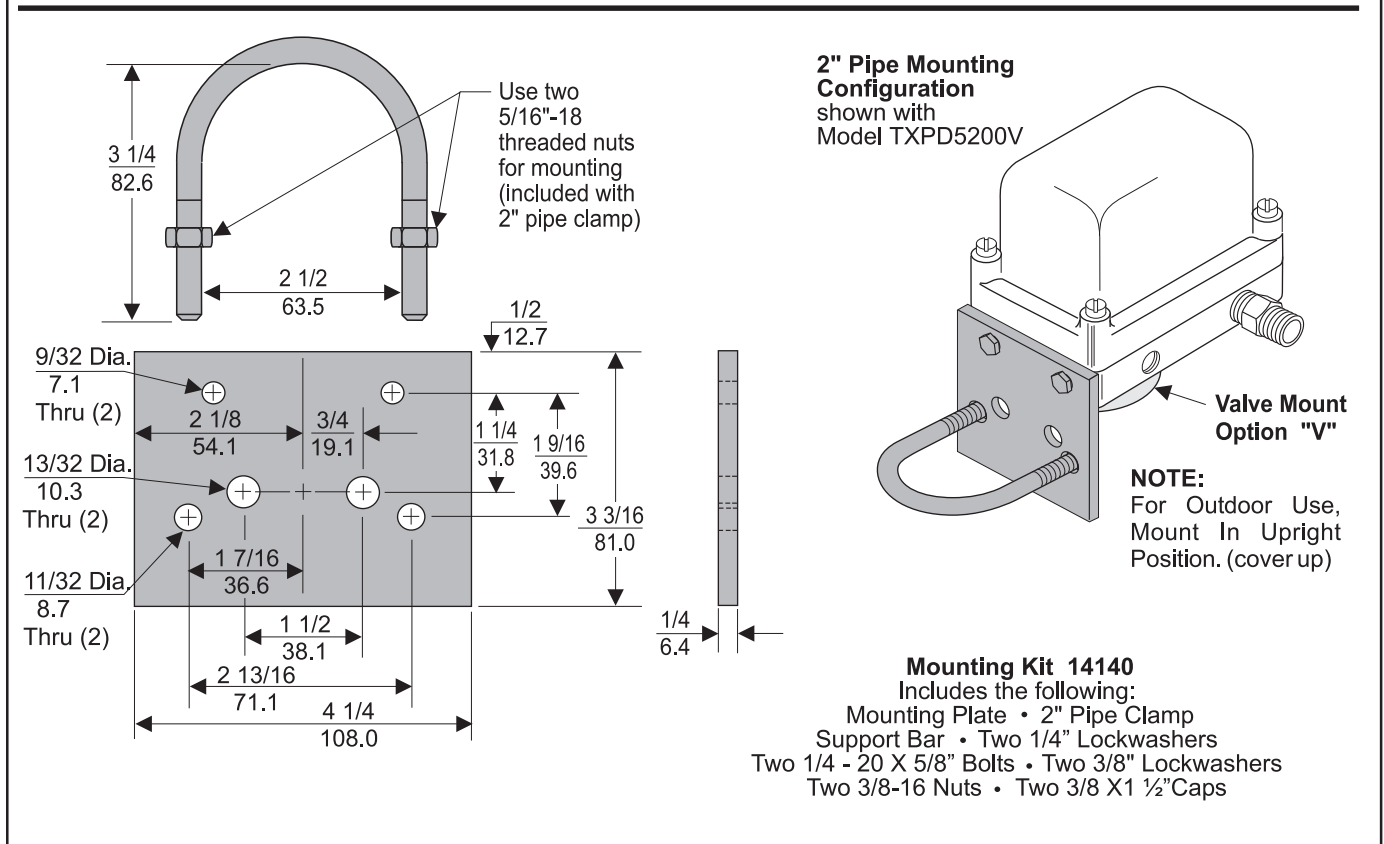

Figure 6. Mounting Kit 14140. (Sold Separately)

Pneumatic Connections

Clean all pipelines to remove dirt and scale before installation.

Apply a minimum amount of pipe compound to the male threads of the fitting only. **Do Not use teflon tape as a sealant.** Start with the third thread back and work away from the end of the fitting to avoid the possibility of contaminating the transducer. Install the transducer in the air line.

The inlet and outlet ports are labeled on the end of the transducer. Tighten connections securely. Avoid undersized fittings that will limit the flow through the transducer and cause a pressure drop down stream. For more information, see Figure 2. "Outline Drawing" on page 3.

NOTES: Instrument quality air, per ISA Standards D7.3-1981, is required. Use a filter to remove dirt and liquid in the air line ahead of the transducer for correct performance. If an air line lubricator is used, it **MUST** be located downstream, beyond the transducer.

The user is responsible for insuring that the environment in which the unit will be installed, and the operating gas, are compatible with the materials in the transducer.

WARNING: To prevent possible ignition of hazardous atmosphere, **DO NOT REMOVE COVER** from the TXPD5200 Transducer while current is on.

To maintain Explosion-Proof capability, **DO NOT DAMAGE** mating surfaces between cover and base. **NEVER ADD GASKETS.**

Electric Connection

For the T5200 Transducer, make connections to the Terminal Block through a 1/2 NPT Conduit Connector (not supplied) and a plastic sleeve as shown below in Figure 7. "Electrical Connections".

For the TXPD5200 Transducer, make connections from the Sealed Connector Wires to an external Terminal Block. The TXPD5200 Transducer has an additional ground wire that is used. For more information, see Figure 7. "Electrical Connections" below.

NOTE: The T5200 & TXPD5200 should be wired in accordance with the wiring diagram inside of cover.

Wiring in Hazardous Areas

Wiring in hazardous areas should be performed in accordance with the Table 1. and any local codes that apply.

Country	Agency	Code
U.S. Canada	FM CSA	ANSI/ISARP 12.6 & ANSI/NFPA 70 CEC Part 1

Intrinsically Safe Connections

Refer to the latest revision of the indicated drawing.

Underwriting Group	Drawing Number
FM (Factory Mutual) CSA (Canadian Standards)	EC-14007 EC-16097

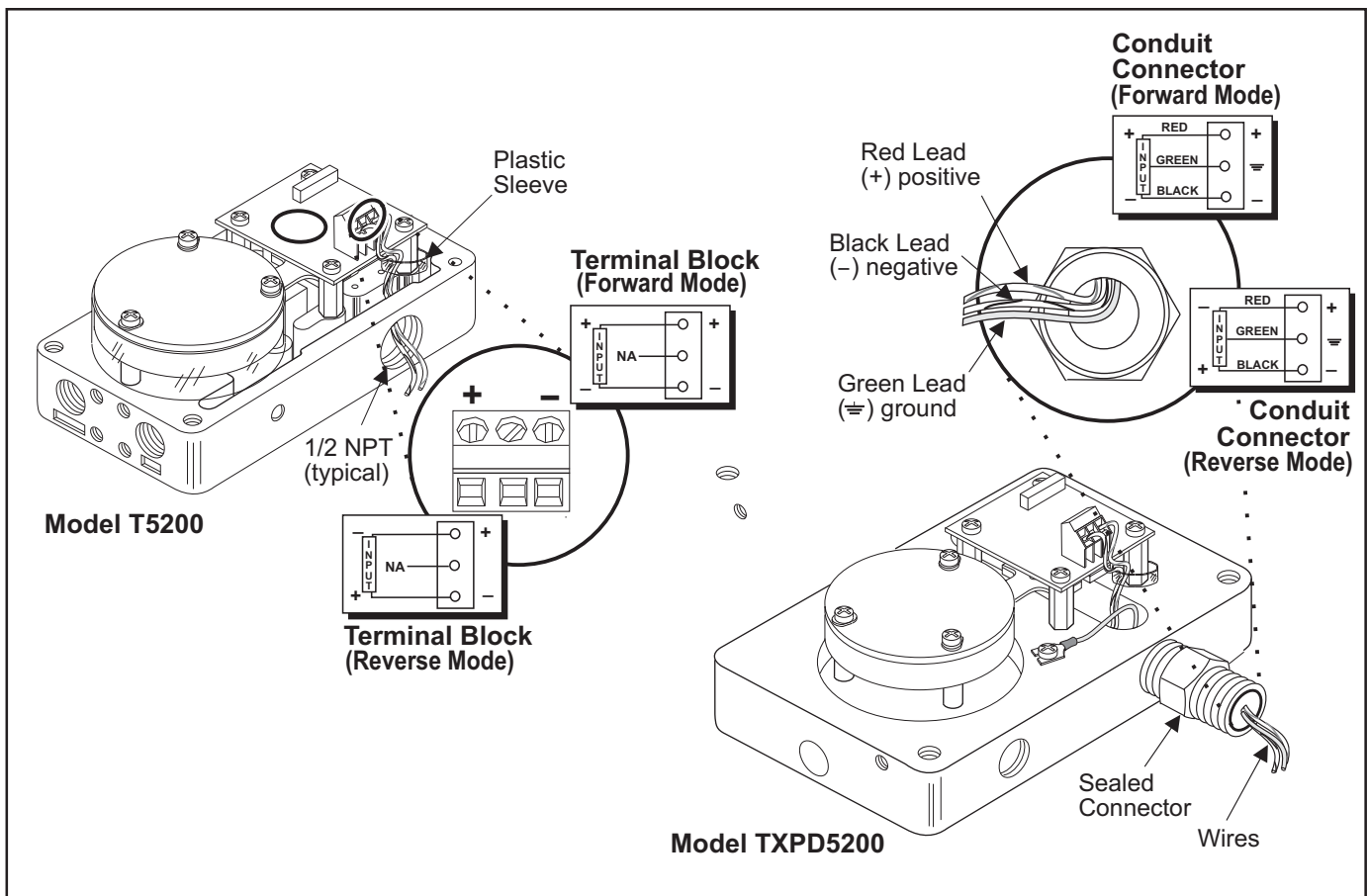

Figure 7. Electrical Connections.

CALIBRATIONS / ADJUSTMENTS

Equipment Required for Calibration:

- Pneumatic Supply capable of delivering up to 150 psig.
- Current Supply capable of delivering up to 50 mA.
- Voltage Supply capable of delivering up to 10 VDC.
- Pressure Gage capable of a digital readout up to 50 psig with an accuracy of .1%.
- Digital Volt Meter capable of a readout up to 30 mA or 10 VDC with an accuracy of .02%.

The following adjustments are provided:

Full Range Operation
 Forward/Reverse Mode
 Calibration - Zero and Span

FULL RANGE OPERATION

Forward Acting Mode Adjustment

1. Connect the input signal to the transducer as shown in Figure 7. "Electrical Connections."

NOTE: Air Supply must be connected before adjustments are made.

- Forward Acting Calibration-Zero
 2. Apply the minimum input signal and adjust the Zero screw for minimum output pressure. Turn screw counterclockwise to increase pressure and clockwise to decrease pressure.

- Forward Acting Calibration-Span

3. Apply the maximum input signal and adjust the Span screw on the potentiometer for maximum output pressure. Turn screw clockwise to increase pressure and counterclockwise to decrease pressure.
4. Repeat steps 2-3 until the desired output range is obtained. For more information, see Figure 8. "T5200/ TXPD5200 Calibration Configuration."

Reverse Acting Mode Adjustment

5. Reverse the input signal connections to the transducer as shown in Figure 7. "Electrical Connections."

- Reverse Acting Calibration-Zero

6. Apply the minimum input signal and adjust the Zero screw for maximum output pressure. Turn screw counterclockwise to increase pressure and clockwise to decrease pressure.

- Reverse Acting Calibration-Span

7. Apply the maximum input signal and adjust the Span screw on the potentiometer for minimum output pressure. Turn screw clockwise to increase pressure and counterclockwise to decrease pressure.

8. Repeat steps 6-7 until the desired output range is obtained. For more information, see Figure 8. "T5200/ TXPD5200 Calibration Configuration."

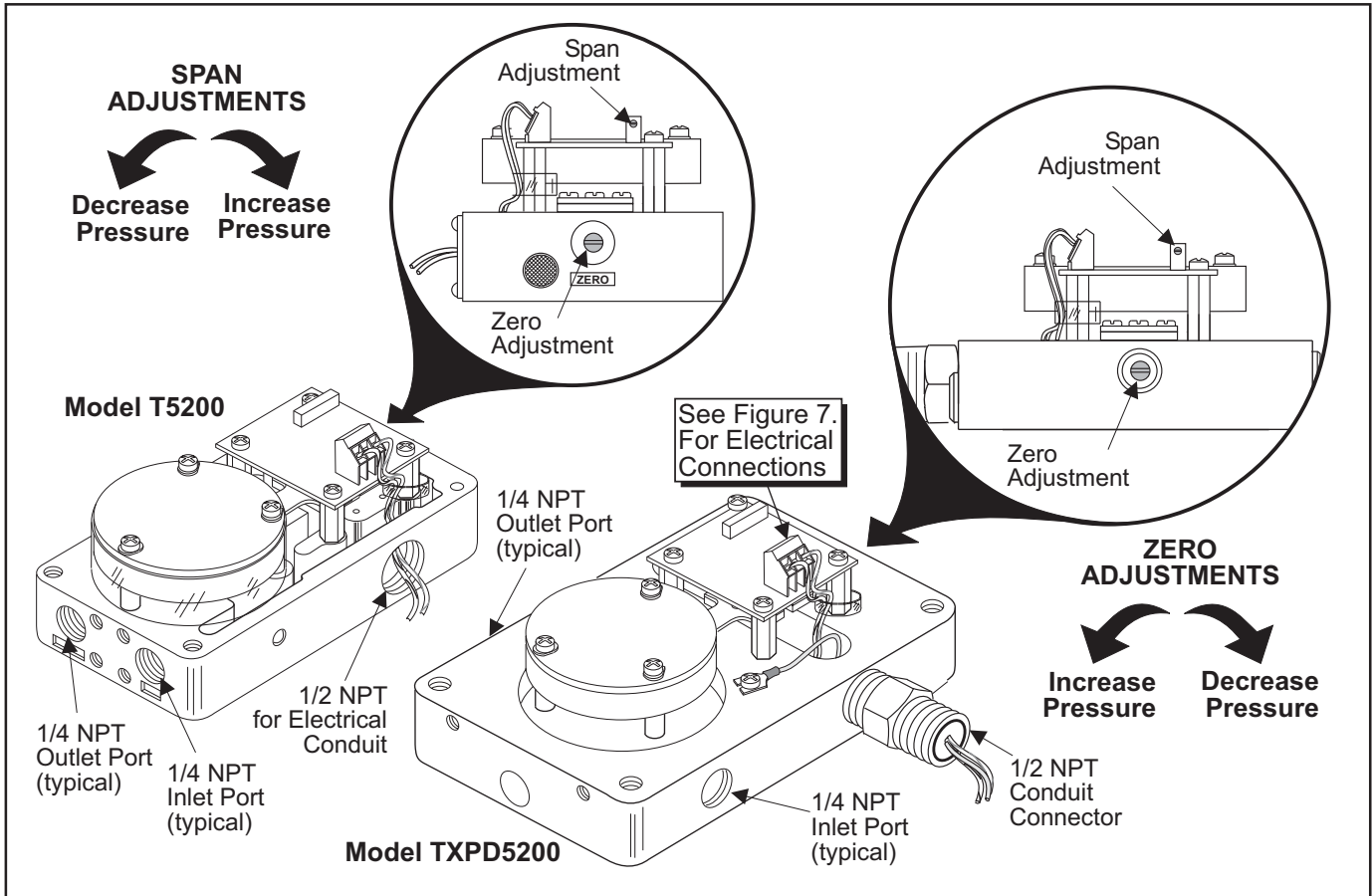

Figure 8. T5200 / TXPD5200 Calibration Configuration.

MAINTENANCE

To clean the Orifice, use the following procedure:

1. Shut off the valve that is supplying air to transducer.
Remove the Air Line from the Inlet Port.
2. Remove the Orifice Assembly (2) from the unit by threading a 1/4-20" Screw into the orifice housing and pulling it out through the inlet port. For more information, see Figure 9. "Exploded Drawing" below.
3. Clean with alcohol and dry with compressed air.

NOTE: Parts must be completely dry before reassembling.

To replace PC Board, use the following procedure:

1. Disconnect wires from Terminal Block on PC Board (4).
2. Unsolder Red (+) and Black (-) Leads on PC Board (4).
3. Remove four Screws (3) holding PC Board (4) to Transducer (1). For more information, see Figure 9. "Exploded Drawing" below.
4. Replace PC Board (4) with the appropriate PC Board from Table 3. on page 9.

To clear problems caused by Magnet malfunction, use the following procedure:

1. Shut off the valve that is supplying air to transducer.
It is not necessary to remove the Transducer from air line.
2. Remove three Screws (5) holding Magnet (6) to Transducer (1).
3. Remove Magnet (6) and clean gap of any foreign material with masking tape. For more information, see Figure 9. "T5200 Exploded Drawing" below.
4. Place Magnet (6) over Coil (7) and tighten with three Screws (5).
5. Using a non-metallic rod, raise up on the arm to make sure Coil (7) is free to move in Magnet (6).

NOTES: If Coil is sticking or dragging, loosen Screws and reposition Magnet. Tighten Screws and repeat step 5.

If the standard maintenance procedure does not correct the problem, install Service Kit.

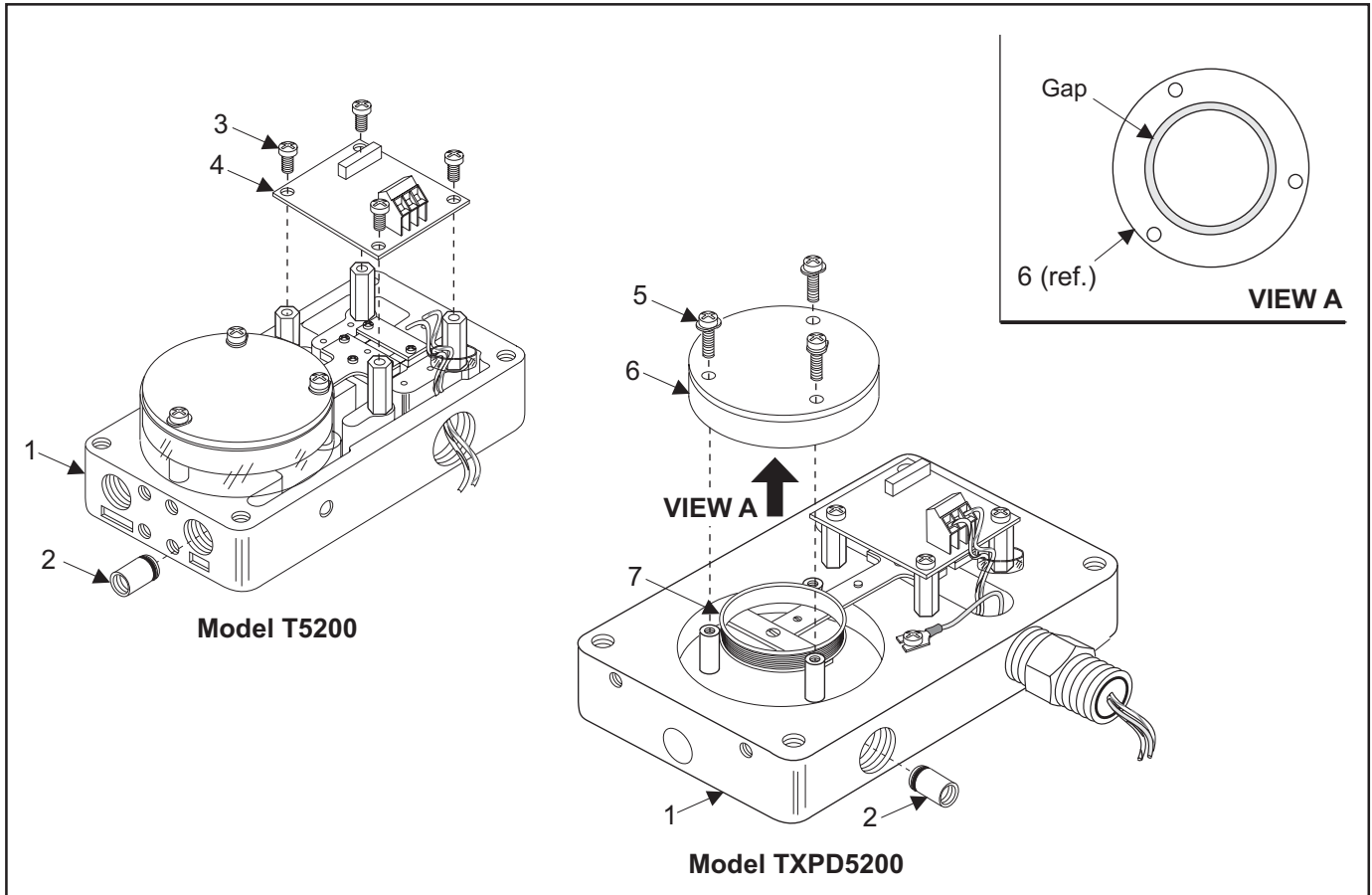

Figure 9. Exploded Drawing.

Maintenance (continued)

Item	Qty.	Part No.	Description
1	1	NS	Transducer
2	1	NS	Orifice
3	4	NS	Screw
4	1	13744-2 ¹	1-5 mA PC Board
4	1	15638-2 ²	1-5 mA PC Board
4	1	13745-2 ¹	4-20,10-50 mA PC Board
4	1	15483-2 ²	4-20,10-50 mA PC Board
4	1	14639-2 ¹	1-5 VDC PC Board
4	1	15640-2 ²	1-5 VDC PC Board
4	1	13746-2 ¹	1-9 VDC PC Board
4	1	15639-2 ²	1-9 VDC PC Board
5	3	NS	Screw
6	1	NS	Magnet
7	1	NS	Coil

¹ For T5200, TF15200, TFN5200, TFN15200, TXPD5200, & TXPDI5200 Units Only.

² For TCI5200 Units Only.

NS: (Not Serviceable) In the Part No. column, indicates that the part is not available for field replacement.

TROUBLE-SHOOTING

Problem	Solution (check)
No Output	Supply Pressure Clogged Orifice
Leakage	Pneumatic Connections
Low or Improper Span Adjust	Zero and Span Adjust Supply Pressure Low Output Leakage
Erratic Operation	DC Signal Loose Wires or Connections Liquid in Air Supply Dirt in Magnet Gap
Unit Does Not Operate	Replace PC Board

LEGAL NOTICE:

The information set forth in the foregoing Installation, Operation and Maintenance Instructions shall not be modified or amended in any respect without prior written consent of Fairchild Industrial Products Company. In addition, the information set forth herein shall be furnished with each product sold incorporating Fairchild's unit as a component thereof.



ISO 9001:2000
FM NO. 25571

**ISO 9001:2000
Certified**



Fairchild Industrial Products Company
3920 West Point Blvd .• Winston-Salem, NC 27103
phone: (336) 659-3400 • fax: (336) 659-9323
sales@fairchildproducts.com • www.fairchildproducts.com

 **FAIRCHILD**
precision pneumatic & motion control

IS-500T5200
Litho in USA
Rev. O 06/07