

FAIRCHILD MODEL 63 PNEUMATIC FILTER REGULATOR

Installation, Operation and Maintenance Instructions

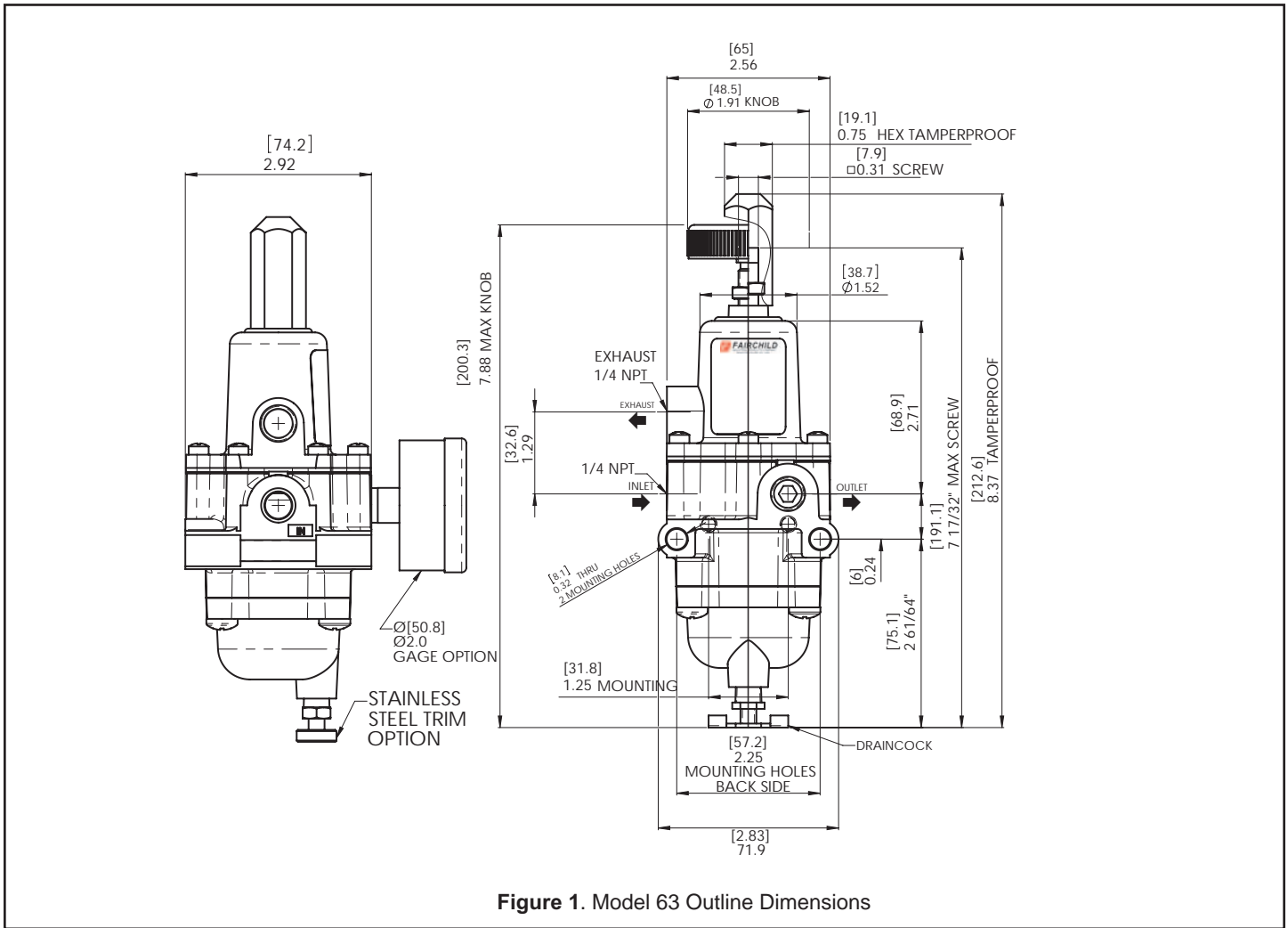

Figure 1. Model 63 Outline Dimensions

INSTALLATION

Use the two 23/64 thru holes in the Body to mount the Model 63. Mount the regulator with the Dripwell Drain Plug at the lowest point for adequate drainage.

Clean all pipelines to remove dirt and scale before installation.

Apply a minimum amount of pipe compound to the male threads of the fitting only. Do Not use teflon tape as a sealant. Start with the third thread back and work away from the end of the fitting to avoid contaminating the regulator. Install the regulator in the air line.

The Inlet and Outlet ports are labeled “In” and “Out”. Tighten all connections securely. Avoid undersized fittings that limit the flow through the regulator. For more information, see **Figure 1**.

NOTE: Oil free air must be applied to the regulator. If an air line lubricator is used, it **MUST** be located downstream of the regulator to avoid interference with performance.

OPERATION

The Model 63 has an Adjustment Screw that controls output pressure. To increase pressure, turn the Adjustment Screw clockwise. To decrease pressure, turn the Adjustment Screw counterclockwise. For more information, see **Figure 1**.

MAINTENANCE

To remove entrained liquids from the Dripwell, open the Drain Plug on the bottom of the Dripwell Assembly. The flow through the regulator and the amount of entrained oil or water in the air determine how often you should empty the Dripwell.

For more information, see **Figure 2**.

NOTE: The presence of some diester oils in the air lines can accelerate elastomer deterioration and decrease the life span of this unit.

TROUBLE SHOOTING

Problem	Source	Solution
Leakage	Body Screw	Tighten the Body Screw
High Bleed	<ul style="list-style-type: none"> • Relief Pintle • Relief Seat 	If contaminated, clean the source
Difficult to Adjust	<ul style="list-style-type: none"> • Adjustment Screw 	Lubricate the Adjustment Screw threads and ends

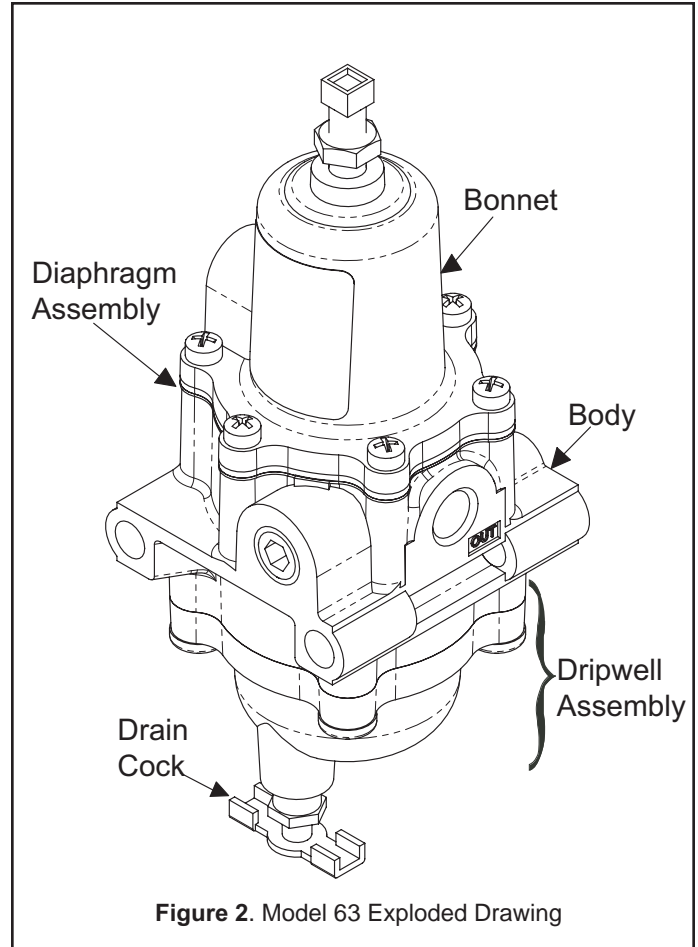

Figure 2. Model 63 Exploded Drawing

NOTE: If the standard maintenance procedure does not correct the problem, install the service kit.

Standard
 • 19968-NR

Pressure Ranges
 • 30 - 120 psig



ISO 9001:2000
 Certified

Fairchild Industrial Products Company
 3920 West Point Blvd. • Winston-Salem, NC 27103
 phone: (336) 659-3400 • fax: (336) 659-9323
 sales@fairchildproducts.com • www.fairchildproducts.com



IS-10000063
 Litho in USA
 Rev B 03/07