



The Model 10 is designed for applications that require high capacity and accurate process control. A poppet valve which is balanced by utilizing a rolling diaphragm, insures a constant output pressure even during wide supply pressure variations. Stability of regulated pressure is maintained under varying flow conditions through the use of an aspirator tube which adjusts the air supply in accordance with the flow velocity.

### Features

- Control sensitivity of 1/8" water column allows use in precision processes.
- Pressure balanced supply valve prevents supply pressure changes from affecting the setpoint.
- Optional check valve permits dumping of downstream pressure when supply is opened to atmosphere.
- Separate control chamber isolates the diaphragm from the main flow to eliminate hunting and buzzing.
- An aspirator tube compensates downstream pressure droop under flow conditions.
- Canadian Registration Number (CRN) certification for all territories and provinces.
- NO Yellow Metals available for harsh media.

### Operating Principles

The Model 10 Series regulator use the force balance principal to control the movement of the Valve Assembly that controls the output pressure. When the regulator is adjusted for a specific set point, the downward force of the Positive Bias Spring moves the Diaphragm Assembly downward. The Supply Valve opens and allows air to pass to the Outlet Port. As the set point is reached, the downward force exerted by the Positive Bias Spring is balanced by the force of the downstream pressure that acts on the Diaphragm Assembly. The resultant force moves the Supply Valve upward to reduce the flow of air to the Outlet Port.

Outlet pressure is maintained as a result of balance between forces acting on the top and bottom of the Diaphragm Assembly.

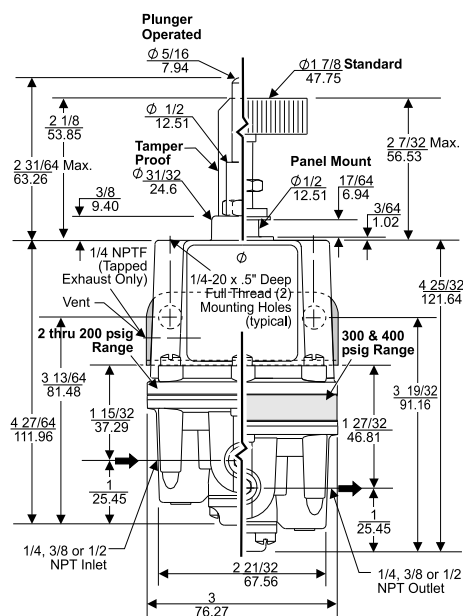
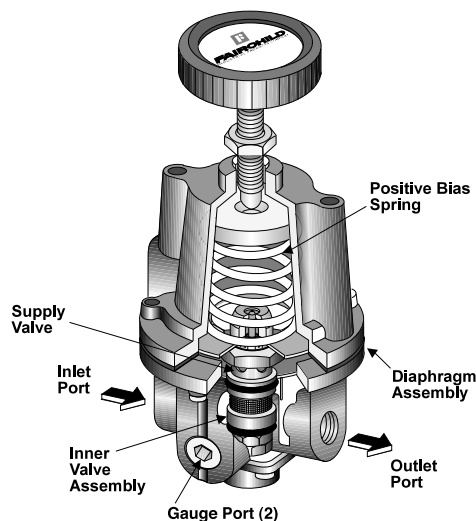

### Options

#### Low Bleed (B)

Option that reduces the bleed rate below that of a standard unit and can be used when bleed or consumption is an issue. A reduction in sensitivity will result from the lower bleed rate.

#### Low Flow (L)

Option that increases the bleed rate above that of a standard unit to improve response in low flow applications.

#### Check Valve (C)

Internal check valve that permits rapid dumping of downstream pressure through the supply line and exhaust port when supply pressure is removed.

#### Non-Relieving (N)

Option that includes no relief function or continuous bleed. Units with this feature must operate with a continuous downstream flow to regulate properly and prevent the output from equalizing with supply line pressure.

### Technical Information

#### Fairchild Model 10262

Operating Characteristics  
Fairchild Model 1022 100 PSI Supply

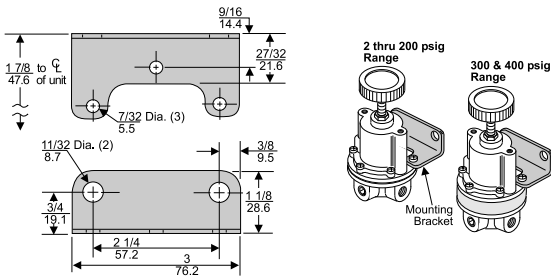
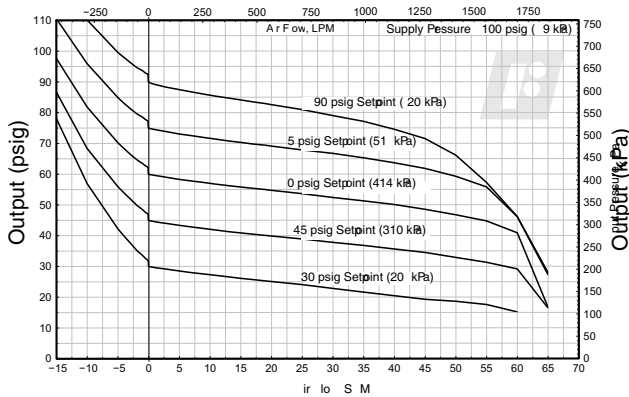

Mounting Bracket: 09921 (sold separately)  
14523 (sold separately)

### Model 10 Regulator Kits & Accessories

Mounting Bracket Kit .....09921 (Zinc Plated Steel)  
14523 (316 Stainless Steel)

### Specifications

#### Supply Pressure

500 psig, [35.0 BAR], (3500 kPa) Maximum

#### Flow Capacity

40 SCFM (68 m<sup>3</sup>/HR) @ 100 psig, [7.0 BAR], (700 kPa) supply and 20 psig, [1.5 BAR], (150 kPa) setpoint

#### Exhaust Capacity

5.5 SCFM (9.35 m<sup>3</sup>/HR) where downstream pressure is 5 psig, [.35 BAR], (35 kPa) above 20 psig, [1.5 BAR], (150 kPa) setpoint

#### Supply Pressure Effect

Less than 0.1 psig, [.007 BAR], (.7 kPa) for 100 psig, [7.0 BAR], (700 kPa) change in supply pressure

#### Ambient Temperature

-40°F to +200°F, (-40°C to 93.3°C)

#### Hazardous Locations

Acceptable for use in Zones 1 and 2 for gas atmosphere; Groups IIA and IIB and Zones 21 and 22 for dust atmospheres

#### Materials of Construction

Body and Housing .....Aluminum  
Diaphragms .....Buna N on Dacron (Std. unit only)  
Trim .....Brass, Zinc Plated Steel

### Catalog Information

Catalog Number 102

#### Pressure Range

psig	[BAR]	(kPa)
0-2	[0-0.15]	(0-15)
0-10	[0-0.70]	(0-70)
0-20	[0-1.5]	(0-150)
.5-30	[0.03-2]	(3-200)
1-60	[0.1-4]	(10-400)
2-150	[0.1-10]	(15-1000)
3-200	[0.2-14]	(20-1400)
5-300	[0.3-21]	(35-2100)
5-400	[0.3-28]	(35-2800)

#### Pipe Size

1/4" NPT	2
3/8" NPT	3
1/2" NPT	4

#### Options

- Silicone Elastomers <sup>1</sup>
- Low Bleed
- Check Valve <sup>2</sup>
- Tapped Exhaust
- BSPP (Parallel) <sup>3</sup>
- Fluorocarbon Elastomers
- Low Flow
- Non-Relieving
- Panel Mount <sup>4</sup>
- Plunger Operated <sup>5</sup>
- Screwdriver Adjust
- Tamper Proof
- BSPT (Tapered)
- No Yellow Metals**

	A	B	C	E	H	J	L	N	P	R	S	T	U	Y
<b>A</b>	-	Y	Y	Y	Y	N	Y	Y	Y	Y	Y	Y	Y	N
<b>B</b>	Y	-	Y	Y	Y	N	N	Y	Y	Y	Y	Y	Y	Y
<b>C</b>	Y	Y	-	Y	Y	Y	N	Y	Y	Y	Y	Y	Y	N
<b>E</b>	Y	Y	Y	-	Y	Y	Y	Y	Y	N	Y	Y	Y	Y
<b>H</b>	Y	Y	Y	Y	-	Y	Y	Y	Y	Y	Y	Y	N	Y
<b>J</b>	N	Y	Y	Y	Y	-	Y	Y	Y	Y	Y	Y	Y	Y
<b>L</b>	Y	N	Y	Y	Y	Y	-	N	Y	Y	Y	Y	Y	Y
<b>N</b>	Y	N	N	Y	Y	Y	N	-	Y	Y	Y	Y	Y	Y
<b>P</b>	Y	Y	Y	Y	Y	Y	Y	Y	-	N	Y	N	Y	Y
<b>R</b>	Y	Y	Y	N	Y	Y	Y	Y	N	-	N	N	Y	N
<b>S</b>	Y	Y	Y	Y	Y	Y	Y	Y	Y	N	-	N	Y	Y
<b>T</b>	Y	Y	Y	Y	Y	Y	Y	Y	N	N	N	-	Y	Y
<b>U</b>	Y	Y	Y	Y	N	Y	Y	Y	Y	Y	Y	Y	-	Y
<b>Y</b>	N	Y	N	Y	Y	Y	Y	Y	Y	N	Y	Y	Y	-

<sup>1</sup> Maximum Supply Pressure - 75 psig, [5.0 BAR], (500 kPa)

<sup>2</sup> Maximum Supply Pressure - 250 psig, [17.0 BAR], (1700 kPa)

<sup>3</sup> BSPP Threads in Inlet & Outlet Ports Only. Others BSPT.

<sup>4</sup> Panel Mount available for ranges 1, 2, 0, 3, 4 and 6 only.

<sup>5</sup> See Table 1 for Push Rod Travel and Thrust.

Table 1. Plunger Operated Regulator Parameters

Range	Push Rod Travel (inches)	Push Rod Thrust (pounds)
0-2 psig	.560 ± 10%	6.28 ± 10%
0-10 psig	.668 ± 10%	31.4 ± 10%
0-20 psig	.668 ± 10%	62.8 ± 10%
.5-30 psig	.673 ± 10%	94.2 ± 10%
1-60 psig	.698 ± 10%	188.4 ± 10%
2-150 psig	.589 ± 10%	471.0 ± 10%
5-300 psig	.589 ± 10%	471.0 ± 10%
3-200 psig	.418 ± 10%	628.0 ± 10
5-400 psig	.418 ± 10%	628.0 ± 10