

# FUNCTIONAL SAFETY SOLUTIONS

ASCO solenoid pilot valves are an integral part of the final control element for any safety instrumented system (SIS) or critical application. ASCO offers 3 solenoid pilot valve solutions that are widely used in the process control industry; individual 3-way pilot valves, manual reset valves, and redundant pilot valve systems. Each of these solutions are proven in use as a pilot valve in critical applications and in safety instrumented systems. Certified pilot valves per IEC 61508 Parts 1 and 2 are rated SIL 3 capable for domestic and international markets (ATEX). ASCO understands the need to keep your process running, but also understands that the process must shut down when commanded.

## 3-Way Pilot Valves

ASCO 3-way solenoids, 8314, 8316, 8320, 8327, 8551 and 8553 are the most widely used solenoid pilot valves in the world. For your spring return actuator applications, these valves are proven in use and have undergone 3rd party evaluation by Exida per IEC 61508 Parts 1 & 2. All 6 series are certified SIL 3 capable. Individual pilot valves are most commonly used in 1-out-of-1 and 1-out-of-2 voting architectures but can be easily piped into a 2-out-of-2 configuration. ASCO pilot valves are used as the primary device for process valve actuation as well as the shutdown valve when used with digital valve controllers for on-off and control valve applications.

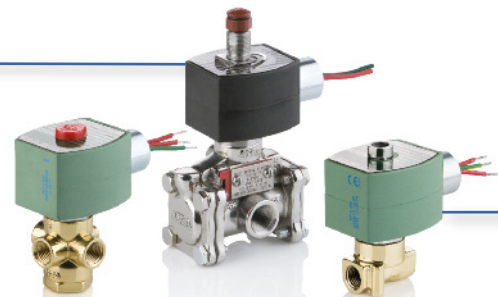

SIL 3 Capable, Certified by Exida

## Manual Reset & Redundant Coil Pilot Valves

ASCO Manual Reset Pilot Valves are a process industry standard, and are certified Sil 3 capable for harsh plant environments where reliability is a must, ASCO has the products to keep your process going. Lever operated manual reset valves are designed with corrosion resistant materials and industrial strength components. When you need to manually engage the final control element of your process system, ASCO has the proven solutions for your applications. Redundant coil pilot valves are also available for your high availability applications.

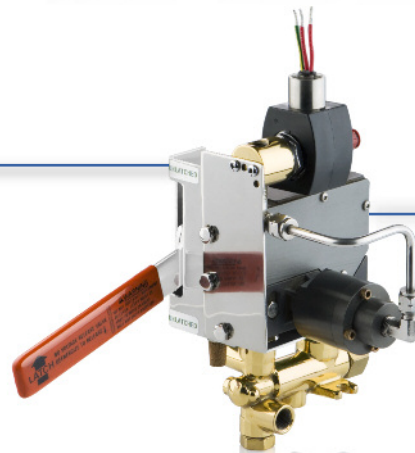

SIL 3 Capable, Certified by Exida  
(Tamper Proof and High Shock Manual Reset Valves)

## Redundant Control Pilot Valve Systems

The ASCO RCS is a redundant pilot valve system that acts as a single 3-way valve. The added features of this system above an individual valve include the ability to perform automatic online testing of the redundant solenoid valves, automatic partial stroke testing of the process valve, and online maintenance capabilities. This product is built for high reliability applications and functional safety. The redundant solenoids can operate in 1-out-of-1 Hot Standby mode or 2-out-of-2 Diagnostic mode. Both modes of operation are certified per IEC 61508 Parts 1 and 2 and are SIL 3 capable. To design an RCS product, please visit [www.ascovalve.com/RCSConfigurator](http://www.ascovalve.com/RCSConfigurator) for the RCS online configurator.



SIL 3 Capable, Certified by Exida,  ATEX Approved

Buy: [www.ValinOnline.com](http://www.ValinOnline.com) | Phone 844-385-3099 | Email: [CustomerService@valin.com](mailto:CustomerService@valin.com)



Gas shut-off valves used in burner applications for process heaters are critical to the refining process. This is one of the more common examples of the need for functional safety. In order for the refining process to run without disruption, the valve cannot trip spuriously, and must shut down when commanded in order to avert an unsafe condition.

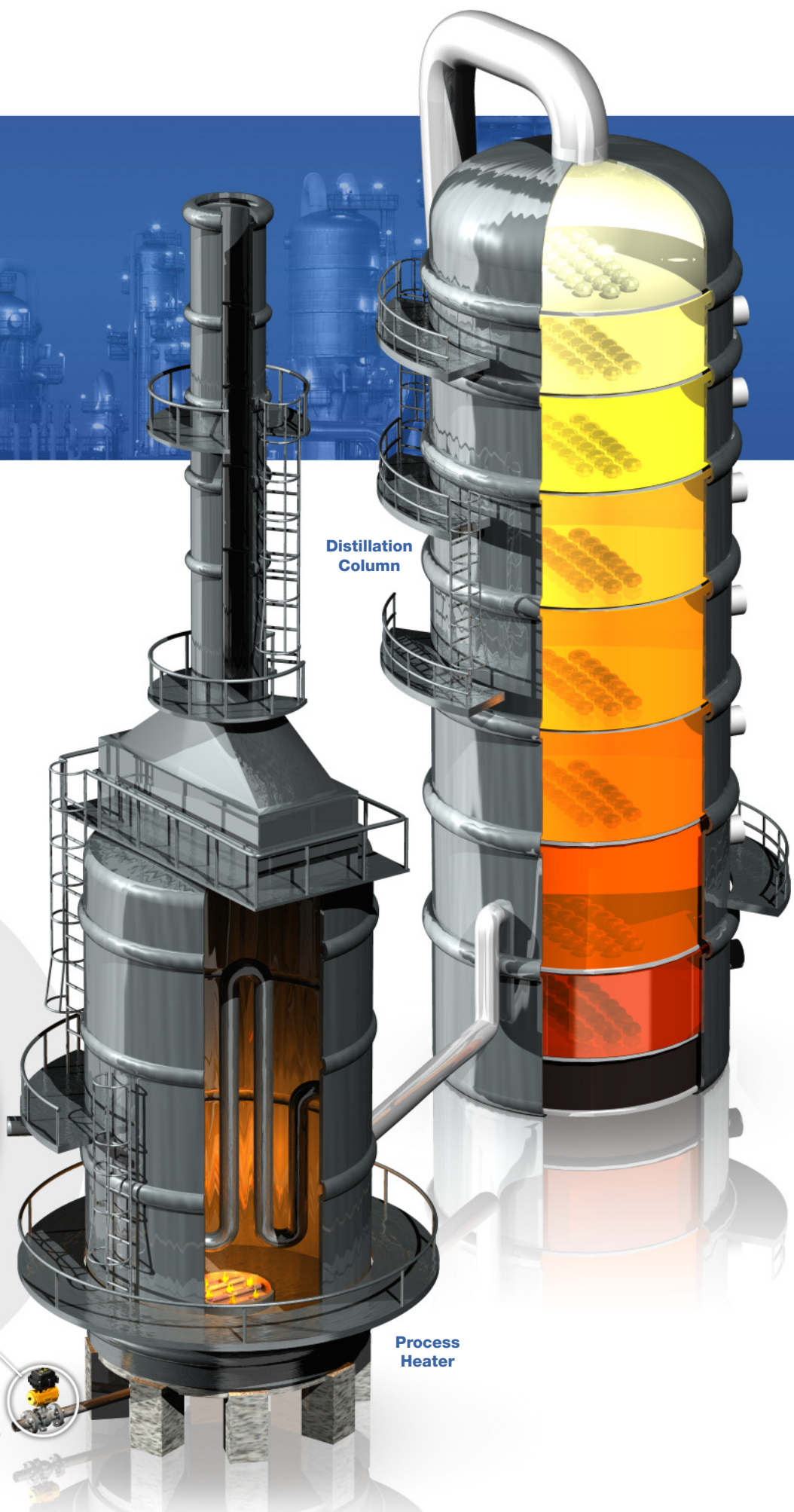

Distillation Column

Process Heater

Process Valve

Fuel Gas Line



## Operational Specifications

### 3-Way Pilot Valves

ASCO 3-way pilot valves certified to IEC 61508 are typically piped in the following two configurations:

#### 1 out-of 1

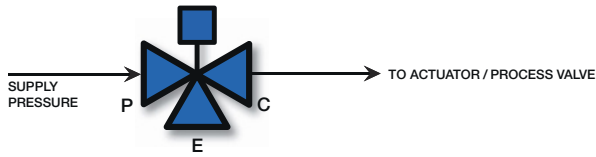

#### 1 out-of 2

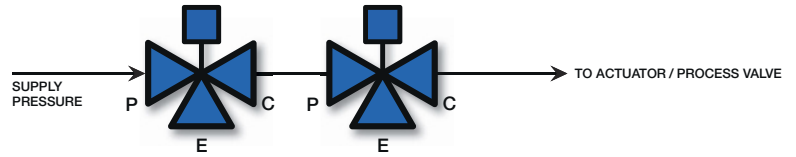

The 1 out-of 1 and 1 out-of 2 configurations are the most common pilot valve configurations used.

#### 2 out-of 2

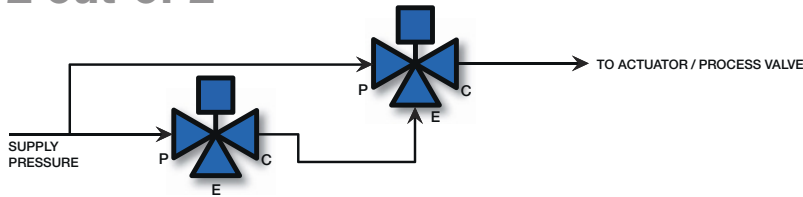

The 2 out-of 2 configurations are commonly used for high availability applications. In the case that one solenoid valve were to spuriously trip, the second solenoid still maintains the position of the actuator/process valve at its operating state. Both solenoids must close in order to shift the actuator/process valve to its non-operating state.

### Redundant Coil Pilot Valves

Redundant coil pilot valves are used for high availability applications. There are two coils (solenoid operators) that are redundantly keeping the main solenoid valve in the energized position, which in turn keeps the actuator/process valve in its operating position. Both coils must be de-energized in order to return the actuator/process valve to its non-operating position.

### Tamper-Proof Manual Reset Valves

**Electrically Tripped** – With the pilot valve solenoid de-energized, the handle is raised manually and latches the operator in the “up” (latched) position. Upon energizing the pilot valve solenoid, the latch is tripped returning the operator to the “down” (unlatched) position. If auxiliary air supply to the pilot valve is lost, the main valve will shift position.

**No Voltage Release** – With the pilot valve solenoid energized, the handle is raised manually and latches the operator in the “up” (latched) position. Upon loss of voltage, the latch is tripped returning the operator to the “down” (unlatched) position. If the auxiliary air supply to the pilot valve is lost, the main valve will shift position.

**Moving the handle while the valve is in its tripped state will not cause the actuator/process valve to shift. (Applies to both electrically tripped and no voltage release tamper-proof manual reset valves)**

### High Shock Manual Reset Valves

**Electrically Tripped** – With the pilot valve solenoid de-energized, the handle is raised manually and latches the operator in the “up” (latched) position. Upon energizing the pilot valve solenoid, the latch is tripped returning the operator to the “down” (unlatched) position.

**No Voltage Release** – With the pilot valve solenoid energized, the handle is raised manually and latches the operator in the “up” (latched) position. Upon loss of voltage, the latch is tripped returning the operator to the “down” (unlatched) position.

**Once tripped, the lever may be cycled causing the valve discs to open and close.**

**(Applies to both electrically tripped and no voltage release high shock manual reset valves)**

### Important

These solenoid valves are intended for use on clean dry air or inert gas, filtered to 40 micrometres or better. The dew point of the media should be at least 10°C (18° F) below the minimum temperature to which any portion of the clean air/inert gas system could be exposed to prevent freezing. If lubricated air is used, the lubricants must be compatible with Nitrile elastomers. Diester oils may cause operational problems. Instrument air in compliance with ANSI/ISA Standard 7.0.01-1996 exceeds the above requirements and is, therefore, an acceptable media for these valves.

### 3-Way Low Power Pilot Valves (0.55 W)\*

Pipe Size (in)	Orifice Size (in)	Cv Flow Factor		Operating Pressure Differential (psi)		Fluid and Ambient Temp. °F		Brass Body		Stainless Steel Body	
				Air-Inert Gas				Min.	Max.	Catalog Number	Const. Ref.
		Pressure to Cylinder	Cylinder to Exhaust	Min.	Max.						
<b>UNIVERSAL OPERATION (Pressure at any port) with NBR Disc – SIL 3 Capable, Certified by Exida ⑤⑦</b>											
1/4	1/20	0.06	0.06	0	130	-40	149	8314H300	1	8314H301 ④	1
<b>NORMALLY CLOSED (Closed when de-energized) with NBR Disc or FPM, as Listed – SIL 3 Capable, Certified by Exida ⑤</b>											
1/4	5/16	1.5	1.5	③	130	-20	149	8316H301 ①	2	EV8316H381 ①④	2A
3/8	5/16	1.8	1.8	③	130	-20	149	8316H302 ①	2	EV8316H382 ①④	2A
3/8	5/8	4	4	③	130	-20	149	8316H303 ①	3	-	-
1/2	5/8	4	4	③	130	-20	149	8316H304 ①	3	EV8316H384 ①④	3A
3/4	11/16	5.5	5.5	10	130	-20	149	8316J374 ①	4	-	-
1	1	13	13	10	130	-4	149	8316H334 ①⑥	5	-	-

① **IMPORTANT:** Internal Mode Minimum Operating Pressure Differential must be maintained between the pressure and exhaust ports. Supply and exhaust piping must be full area, unrestricted. ASCO flow controls and other similar components must be installed in the cylinder lines only. See graph on page 6 for main line pressure vs. pilot line pressure.

③ Zero minimum when valve selection gasket is in external position and proper auxiliary air pressure is applied. Minimum 15 psi Operating Pressure Differential when selection gasket is in the internal position (see graph on page 6 for mainline vs. pilot line pressure).

④ Can be used for *dry* natural gas service (no agency approvals) with the EF or EV prefix.

⑤ Safety manual and FMEDA (Failure Modes Effects and Diagnostic Analysis) report available.

⑥ Solenoid only approvals with EF or EV prefix, no approvals with general purpose coil (no prefix).

⑦ SIL 3 Capable, Certified by Exida, only valid when used as Normally Closed.

\***IMPORTANT:** Supervisory and leakage current above the drop out current of 1.8 mA for 24V DC will cause improper operation. Consult your local ASCO sales office for additional assistance.

### 3-Way Low Power Pilot Valves (1.4 W)\*

Pipe Size (in)	Orifice Size (in)	Cv Flow Factor		Operating Pressure Differential (psi)		Fluid and Ambient Temp. °F		Brass Body		Stainless Steel Body	
				Air-Inert Gas				Min.	Max.	Catalog Number	Const. Ref.
		Pressure to Cylinder	Cylinder to Exhaust	Min.	Max.						
<b>UNIVERSAL OPERATION (Pressure at any port) with NBR Disc – SIL 3 Capable, Certified by Exida ⑤⑥</b>											
1/4	1/16	.08	.08	0	150	-40	140	8314G300	6	8314G301 ④	7
<b>NORMALLY CLOSED (Closed when de-energized) with NBR Disc or FPM, as Listed – SIL 3 Capable, Certified by Exida ⑤</b>											
1/4	5/16	1.5	1.5	③	150	-20	149	8316G301 ①	8	EV8316G381 ①④	8
3/8	5/16	1.8	1.8	③	150	-20	149	8316G302 ①	8	EV8316G382 ①④	8
3/8	5/8	4	4	③	150	-20	149	8316G303 ①	9	-	-
1/2	5/8	4	4	③	150	-20	149	8316G304 ①	9	EV8316G384 ①④	9
3/4	11/16	5.5	5.5	10	150	-20	149	8316H374 ①	4	-	-
1	1	13	13	10	150	-4	140	8316G334 ①	5	-	-

① **IMPORTANT:** Internal Mode Minimum Operating Pressure Differential must be maintained between the pressure and exhaust ports. Supply and exhaust piping must be full area, unrestricted. ASCO flow controls and other similar components must be installed in the cylinder lines only. See graph on page 6 for main line pressure vs. pilot line pressure.

③ Zero minimum when valve selection gasket is in external position and proper auxiliary air pressure is applied. Minimum 15 psi Operating Pressure Differential when selection gasket is in the internal position (see graph on page 6 for mainline vs. pilot line pressure).

④ Can be used for *dry* natural gas service (no agency approvals) with the EF or EV prefix.

⑤ Safety manual and FMEDA (Failure Modes Effects and Diagnostic Analysis) report available.

⑥ SIL 3 Capable, Certified by Exida, only valid when used as Normally Closed.

\***IMPORTANT:** Supervisory and leakage current above the drop out current of 7mA for 24V DC will cause improper operation. Consult your local ASCO sales office for additional assistance.

### 3-Way Pilot Valves (8314 Series)

Pipe Size (in)	Orifice Size (in)	Cv Flow Factor 2-1	Cv Flow Factor 1-3	Operating Pressure Differential (psi)						Min. Fluid and Ambient Temp. °F	Max. Fluid Temp. °F ②		Max. Ambient Temp. °F		Brass Body		Stainless Steel Body		Watt Rating/Class of Coil Insulation		
				Max. AC			Max. DC				AC	DC	AC	DC	Catalog Number	Const. Ref.	Catalog Number	Const. Ref.	AC	DC	
				Air-Inert Gas	Water	Lt. Oil @ 45 SSU	Air-Inert Gas	Water	Lt. Oil @ 45 SSU												
<b>NORMALLY CLOSED (Closed when de-energized) – SIL 3 Capable, Certified by Exida ①</b>																					
1/8	3/64	0.05	0.06	300	300	300	250	250	250	-13	200	200	131	131	8314H031	10	8314H037	10	10.1/F	11.6/F	
1/8	3/32	0.15	0.20	205	205	190	150	120	90	-13	200	200	131	131	8314H032	10	8314H038	10	10.1/F	11.6/F	
1/8	1/8	0.25	0.20	145	145	100	90	90	70	-13	200	200	131	131	8314H033	10	8314H039	10	10.1/F	11.6/F	
1/4	3/64	0.05	0.06	300	300	300	250	250	250	-13	200	200	131	131	8314H034	11	8314H068	11	10.1/F	11.6/F	
1/4	3/32	0.15	0.20	205	205	190	150	120	90	-13	200	200	131	131	8314H035	11	8314H121	11	10.1/F	11.6/F	
1/4	1/8	0.25	0.20	145	145	100	90	90	70	-13	200	200	131	131	8314H036	11	8314H126	11	10.1/F	11.6/F	
1/4	5/32	0.50	0.20	75	75	75	50	50	50	-13	200	200	131	131	8314H130	11	8314H230	11	10.1/F	11.6/F	
1/4	7/32	0.70	0.20	40	40	40	25	25	25	-13	200	200	131	131	8314H131	11	8314H231	11	10.1/F	11.6/F	
1/4	9/32	0.85	0.20	25	25	25	15	15	15	-13	200	200	131	131	8314H132	11	8314H232	11	10.1/F	11.6/F	

① Safety manual and FMEDA (Failure Modes Effects and Diagnostic Analysis) report available.

② Max. Fluid Temp 180 F for light oil @ 45 SSU

### 3-Way Pilot Valves (8320 Series)

Pipe Size (in)	Orifice Size (in)	Cv Flow Factor	Operating Pressure Differential (psi)						Min. Fluid and Ambient Temp. °F	Max. Fluid Temp. °F		Max. Ambient Temp. °F		Brass Body		Stainless Steel Body		Watt Rating/Class of Coil Insulation ①	
			Max. AC			Max. DC				AC	DC	AC	DC	Catalog Number	Const. Ref.	Catalog Number	Const. Ref.	AC	DC
			Air-Inert Gas	Water	Lt. Oil @ 300 SSU	Air-Inert Gas	Water	Lt. Oil @ 300 SSU											
<b>NORMALLY CLOSED (Closed when de-energized) – SIL 3 Capable, Certified by Exida ④</b>																			
1/8	3/64	0.06	200	200	200	200	200	200	32	180	120	125	104	8320G132	12	8320G142 ②	12	6.1/F	10.6/F
1/8	1/16	0.09	150	125	125	125	125	125	32	180	120	125	104	8320G013	12	8320G045 ②	12	6.1/F	10.6/F
1/8	1/16	0.09	210	225	225	160	160	160	32	200	150	125	104	8320G215	13	8320G224 ③	13	17.1/F	11.6/F
1/8	3/32	0.12	100	100	100	100	100	100	32	180	120	125	104	8320G015	12	8320G047 ②	12	6.1/F	10.6/F
1/8	3/32	0.12	150	150	150	115	115	115	32	200	150	125	104	8320G216	13	8320G225 ③	13	10.1/F	11.6/F
1/8	1/8	0.21	40	40	40	40	40	40	32	180	120	125	104	8320G017	12	8320G049 ②	12	6.1/F	10.6/F
1/8	1/8	0.21	85	85	85	60	60	60	32	200	150	125	104	8320G217	13	8320G226 ③	13	10.1/F	11.6/F
1/4	1/16	0.09	210	225	225	160	160	160	32	200	150	125	104	8320G182	14	8320G231 ③	15	17.1/F	11.6/F
1/4	3/32	0.12	150	150	150	115	115	115	32	200	150	125	104	8320G184	14	8320G202 ②③	15	10.1/F	11.6/F
1/4	1/8	0.25	85	85	85	60	60	60	32	200	150	125	104	8320G186	14	8320G203 ②③	15	10.1/F	11.6/F
1/4	11/64	0.35	45	45	45	25	25	25	32	200	150	125	104	8320G188	14	-	-	10.1/F	11.6/F

① On 50 hertz service, the watt rating for the 6.1/F solenoid is 8.1 watts  
 ② Can be used for *dry* natural gas service with the EF or EV prefix.  
 ③ Constructions standard rated -40°F ambient temperature. EFX prefix and TPL # not required  
 ④ Safety manual and FMEDA (Failure Modes Effects and Diagnostic Analysis) report available.

### 3-Way Pilot Valves (8327 Series)

Pipe Size (in)	Orifice Size (in)	Cv Flow Factor		Operating Pressure Differential (psi)			Min. Fluid and Ambient Temp. °F	Max. Fluid Temp. °F	Max. Ambient Temp. °F	Brass Body		316 Stainless Steel Body		Watt Rating/Class of Coil Insulation	
		Ports 1-2	Ports 2-3	Max. DC						Catalog Number	Const. Ref.	Catalog Number	Const. Ref.	AC	DC
				Air-Inert Gas	Water	Lt. Oil @ 45 SSU									
<b>UNIVERSAL OPERATION (Pressure at any port) – SIL 3 Capable, Certified by Exida ①</b>															
1/4	1/4	0.49	0.56	150	150	150	-4	176	131	8327G041	16	-	-	12.0/F	11.6/F
1/4	1/4	0.49	0.56	150	150	150	-4	248	131	-	-	EV8327G042	16	12.0/F	11.6/F
1/4	1/4	0.49	0.56	150	-	-	-40	131	131	8327G051	16	-	-	12.0/F	11.6/F
1/4	1/4	0.49	0.56	150	-	-	-40	131	131	-	-	EV8327G052	16	12.0/F	11.6/F

① Safety manual and FMEDA (Failure Modes Effects and Diagnostic Analysis) report available. SIL 3 Capable, Certified by Exida, only valid when used as Normally Closed.

### 3-Way Pilot Valves (8551/8553 Series)

Pipe Size (in)	Orifice Size (in)	Cv Flow Factor	Operating Pressure Differential (psi)			Fluid and Ambient Temp °F			Aluminum Body		Watt Rating/Class of Coil Insulation	
			Air-Inert			Min.	Max. AC	Max. DC	Catalog Number	Const. Ref.	AC	DC
			Min.	Max. AC	Max. DC							
<b>NORMALLY CLOSED – OPEN FRAME DIN COIL – SIL 3 Capable, Certified by Exida ①</b>												
1/4	1/4	0.86	30	150	5	140	140	SC8551A005MS	17	2.5/F	3.0/F	
1/2	1/2	3.7	30	150	-15	140	140	SC8553A005MS	17	5.0/F	6.9/F	
<b>NORMALLY CLOSED – WATERTIGHT ENCLOSURE – SIL 3 Capable, Certified by Exida ①</b>												
1/4	1/4	0.86	30	150	5	140	77	WT8551A005MS	17	6.3/F	6.9/F	
1/2	1/2	3.7	30	150	-15	140	77	WT8553A005MS	17	6.3/F	6.9/F	
<b>NORMALLY CLOSED – EXPLOSIONPROOF ENCLOSURE – SIL 3 Capable, Certified by Exida ①</b>												
1/4	1/4	0.86	30	150	5	104	77	EF8551A005MS	17	6.3/F	6.9/F	
1/2	1/2	3.7	30	150	-15	104	77	EF8553A005MS	17	6.3/F	6.9/F	

① Safety manual and FMEDA (Failure Modes Effects and Diagnostic Analysis) report available.

### 3-Way Pilot Valves (8551/8553 Series)

Pipe Size (in)	Orifice Size (in)	Cv Flow Factor	Operating Pressure Differential (psi)			Fluid Temp. °F			Ambient Temp. °F			Aluminum Body	Brass Body	316L Stainless Steel Body	Const. Ref.	Watt Rating/Class of Coil Insulation	
			Air-Inert			Max. AC	Max. DC	Min.	Max. AC	Max. DC	Catalog Number					AC	DC
			Min.	Max. AC	Max. DC												
<b>NORMALLY CLOSED – SIL 3 Capable, Certified by Exida ①</b>																	
1/4	1/4	0.86	30	145	120	140	120	5	125	104	8551G405	-	-	18	10.1/F	11.6/F	
1/4	1/4	0.86	30	145	120	140	120	-40	125	104	-	EF8551G407③	-	18	10.1/F	11.6/F	
1/4	1/4	0.86	30	145	120	140	120	-40	125	104	-	-	EV8551G413②	18	10.1/F	11.6/F	
1/2	1/2	3.7	30	145	120	140	120	5	125	104	8553G405	-	-	18	10.1/F	11.6/F	
1/2	1/2	3.7	30	145	120	140	120	-40	125	104	-	-	EV8553G413②	18	10.1/F	11.6/F	

① Safety manual and FMEDA (Failure Modes Effects and Diagnostic Analysis) report available.  
 ② Stainless steel construction supplied standard with EV solenoid.  
 ③ Brass construction supplied standard with EF solenoid.

# Dimensions: inches [mm]

Const. Ref.		A	B	C	F	H	K	L	M	N	P	R	S	W
2	in	0.84	4.68	2.08	5.41	5.01	2.73	2.06	1.06	1.28	4.23	4.06	3.83	3.26
	mm	21	119	53	137	127	69	52	27	33	107	103	97	83
3	in	1.19	4.88	2.18	5.90	5.40	2.98	2.72	1.24	1.32	4.48	4.26	4.03	3.59
	mm	30	124	56	150	167	76	69	31	34	114	108	102	91
2A	in	1.00	4.71	2.11	5.57	5.17	2.73	2.06	1.08	1.28	4.24	4.09	3.86	3.28
	mm	25	120	54	141	131	69	52	27	33	108	104	98	83
3A	in	1.11	4.88	2.18	5.98	5.48	2.84	2.72	1.24	1.37	4.34	4.26	4.04	3.59
	mm	28	124	55	152	139	72	69	31	35	110	108	102	91

## Main Line Pressure vs. Pilot Line Pressure

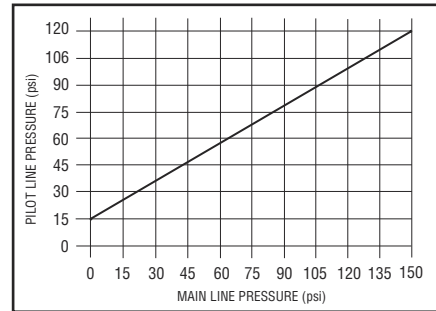

### Const. Ref. 1

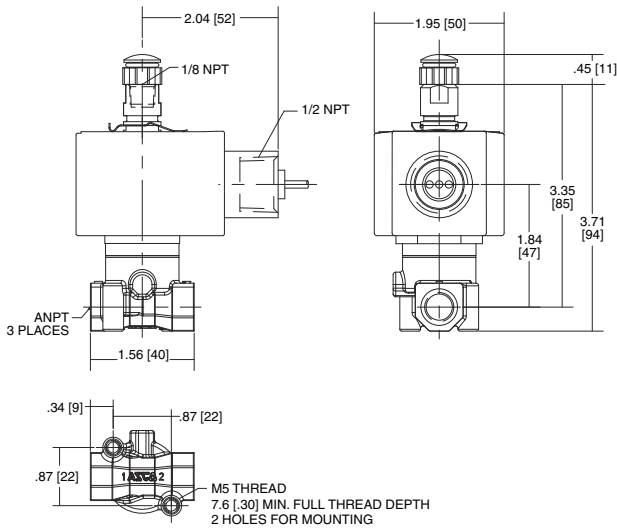

### Const. Ref. 2, 2A, 3, 3A

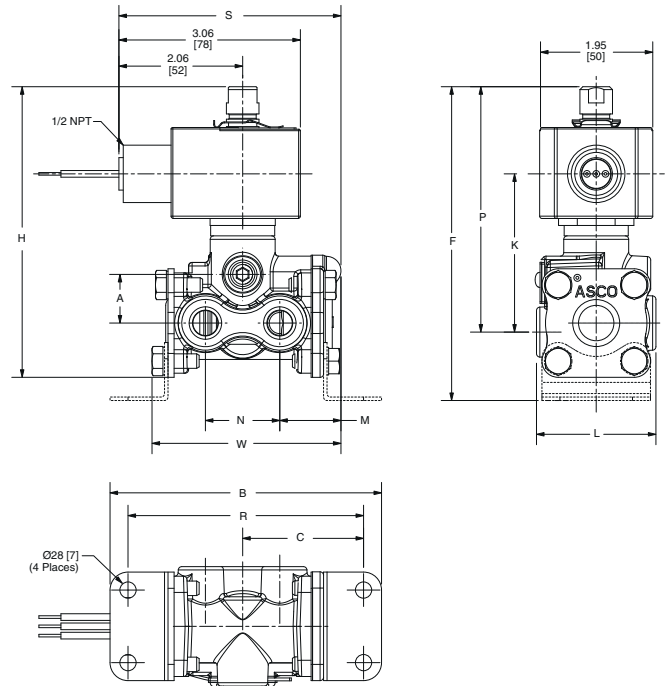

Const. Ref.		A	H	K	L	M	P
4	in	1.61	6.78	3.68	3.38	2.16	5.09
	mm	41	172	93	86	55	129
5	in	-	7.40	3.93	4.44	2.81	5.34
	mm	-	188	100	113	71	136

### Const. Ref. 4, 5

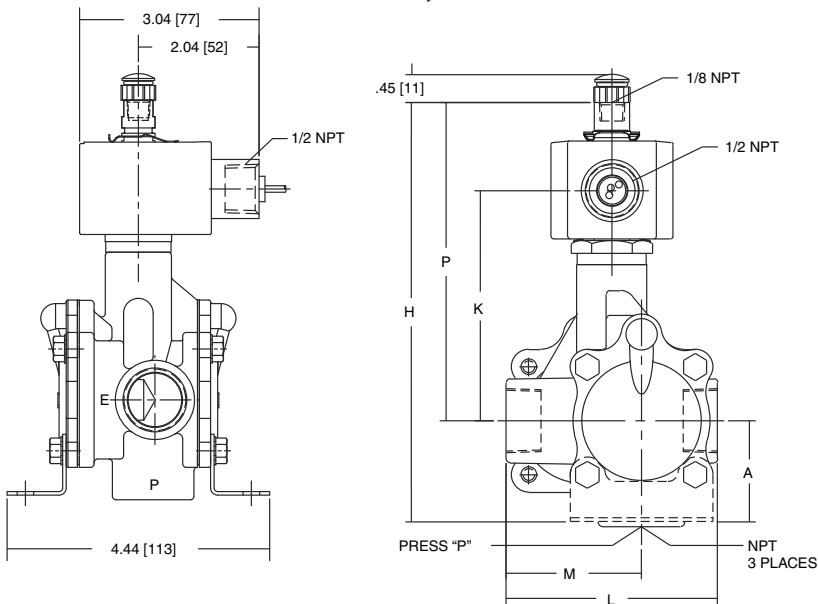

OPTIONAL MOUNTING BRACKET WITH  $\varnothing .28$  [7] HOLES [4 PLACES] AVAILABLE ON 3/4 SIZE ONLY

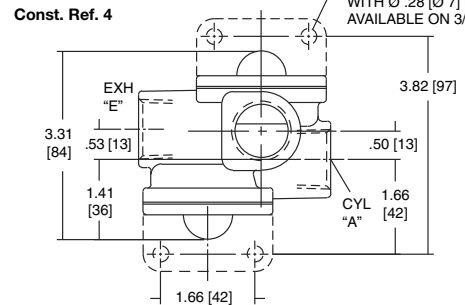

### Const. Ref. 5

