

BREATHERS:

Standards

Basic protection from moisture and particulate contamination in lubricant and equipment



APPLICATIONS:

- Totes
- Transformers
- Storage Tanks
- Hydraulics



The Overview

Standard Breathers: Typical Industries

- Power Generation
- Mining
- Aviation
- Storage
- Manufacturing
- Petrochemical

By the Numbers:

1-Integrated Nylon Standpipe

The integrated standpipe provides excellent vibration resistance and dissipates impact throughout the unit, eliminating weak points. It also allows even airflow distribution throughout the unit, eliminating inaccurate readings of desiccant saturation.

2-Resilient Polycarbonate Body

Shock-absorbing, clear casing provides reliable service and easy maintenance.

3-Filter Element

Polyester filter element removes airborne contamination to 3-micron absolute. Unique loops allow particles to release during system exhalation, helping to increase breather life.

4-Foam Pad

Foam filter captures any oil mist and disperses incoming air evenly over filtration and drying areas.

5-Water Vapor Adsorbent

Silica gel adsorbs water from incoming air and can hold up to 40% of its weight. Condition is indicated by change of color from blue to light pink.

6- Secondary Filter Element

Second polyester filter element protects against migration of desiccant dust, providing maximum efficiency.

7-Threaded Mounting

Easily replaces standard filler/breather cap with multi-fit connection or one of several adapters.

8-Air Vents

Individual air intakes are opened based on flow requirements of the system. Plugs protect unit during shipping and storage.

How It Works:

This breather unit replaces the standard dust cap or OEM breather cap on equipment. As air is drawn into equipment through the breather, the layered filter elements remove particulate while the desiccant beads strip harmful moisture.

While in service or during shut-down, the desiccant beads attract moisture from inside the equipment reservoir, actively drying the equipment.

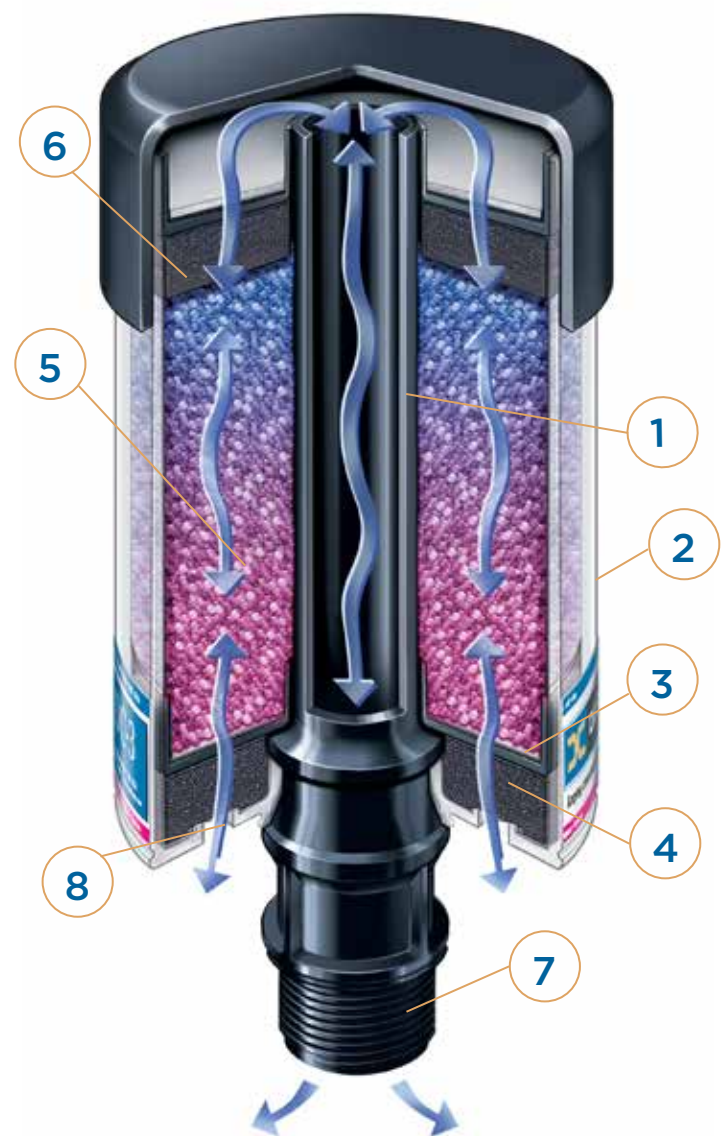

Charts & Graphs

Materials & Components:

Filter Housing: Polycarbonate, nylon, polypropylene, PVC, Buna-N

Filter Media: Polyurethane, polyester

Hydrophilic Media: Silica gel

Filter Efficiency:

(3 μ absolute ($\beta_3 \geq 200$))

Recommended Temperature Range:

-20°F to 200°F

-29°C to 93°C

Chemical Compatibility:

Recommended:

All Gear Oil

Most Hydraulic Fluid

Mineral & Synthetic Oil

Not Recommended:

Phosphate Ester

Hydrogen Sulfide

Sulfuric Acid

Highly Alkaline Cleaners

Humidity Protection:

A Des-Case standard breather is five times more effective than leading non-desiccant breather.

Humidity Level Below Ambient Conditions:

DC-4: protects 30,000+ cycles

Deliquescent: protects 5,000 cycles

(Testing parameters 73°F, 1cfm)*

*See test results on page 4.

Sizing Recommendations:

Model	Max. Airflow at 1psid	Recommended Max. Volume	
		Gearbox/Storage Tank	Hydraulic Reservoir
DC-BB	4.55cfm/129lpm	15gal/57L	2gal/8L
DC-1	4.16cfm/118lpm	35gal/132L	5gal/19L
DC-2	16cfm/453lpm	200gal/757L	60gal/227L
DC-3	16cfm/453lpm	350gal/1325L	100gal/379L
DC-4	16cfm/453lpm	500gal/1893L	200gal/757L

Water Adsorption Capacity:

Size	Maximum Water Retention
DC-BB	23ml / 0.8fl. oz.
DC-1	50ml / 4fl. oz
DC-2	118ml / 4fl. oz
DC-3	220ml / 7.45fl. oz.
DC-4	353ml / 11.3 fl. oz

Dimensions & Connections:

Model	Connection	Unit Height	Unit Width
DC-BB	" Multi-Fit (NPT, BSPP, BSPT)	3.90in	2.5in
		9.9cm	6.4cm
DC-1	" Multi-Fit (NPT, BSPP, BSPT)	5.351in	2.5in
		13.5cm	6.4cm
DC-2	1" Multi-Fit (NPT, BSPP, NPSM)	6in	4in
		15.6cm	10.2cm
DC-3	1" Multi-Fit (NPT, BSPP, NPSM)	8in	4in
		20.6cm	10.2cm
DC-4	1" Multi-Fit (NPT, BSPP, NPSM)	10in	4in
		25.7cm	10.2cm



ADDITIONAL SPECS.

Airflow:

DC-BB

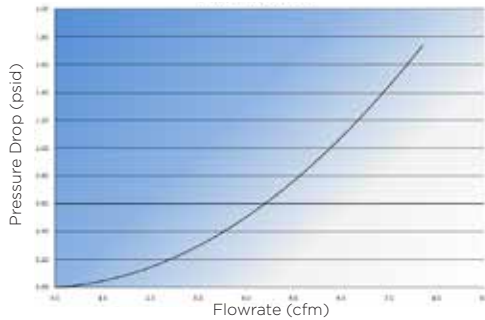

DC-1

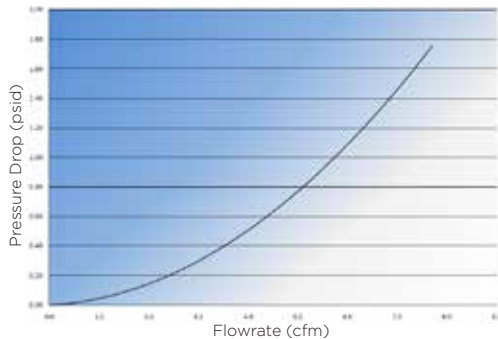

DC-2, DC-3, DC-4

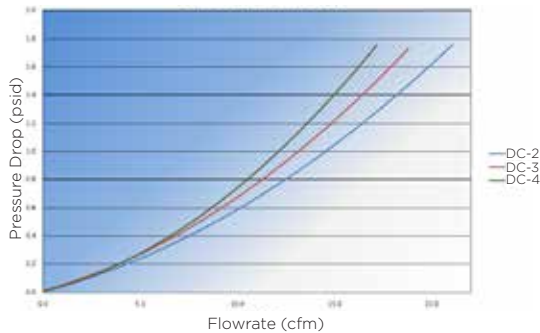

Miniatures:

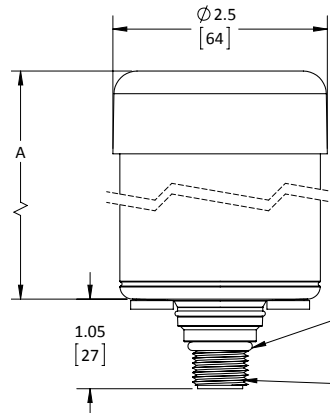

Standard Sizes:

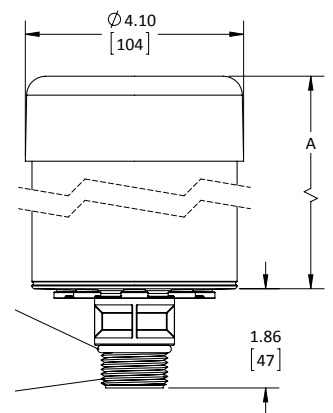

Breathers	A
DC-BB	2.824
DC-1	4.307

Breathers	A
DC-2	4.13
DC-3	6.13
DC-4	8.13

Humidity Protection:

Desiccant vs. Deliquescent (73°F, 1cfm)

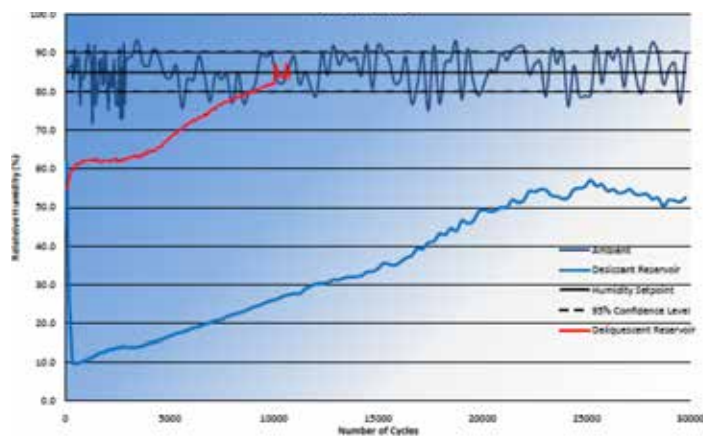

A Des-Case standard breather is five times more effective than leading non-desiccant breather.

Humidity Level Below Ambient Conditions:

DC-4: protects 30,000+ cycles

Deliquescent: protects 5,000 cycles

(Testing parameters 73°F, 1cfm)

Des-Case Corporation | 675 N. Main St. | Goodlettsville, TN 37072
D: 615.672.8800 | F: 615. 672.0701 | descase.com