

FLUID HANDLING:

LT Series Lubricant Management System (LT-LMS)

This system combines filtration, storage, and breathers in one simple solution to keep your lubricants clean and dry.



The Overview

The LT-LMS:

Where It's Used

- Storing lubricant
- Dispensing new oil
- Pre-filtering new oil
- Collecting oil samples for analysis

What Is Standard?

- Automatic pressure relief valve
- Dedicated pump and motor per tank
- Desiccant breathers
- Heavy-duty stand
- 12' hose assemblies with various hose-end connections
- One-year warranty
- Industrial powder-coated paint

What Can I Customize?

- Flow rates
- Various tank sizes in high-density polyethylene (HDPE) or steel
- Manual gravity drain
- Sample valves
- Filter micron rating
- Hose-end connection sizes and types

Did You Know?

New oil isn't clean. One of the best places to start any improvement is in the lube room. While it may not have the biggest effect on the quality of the lubricant in each machine, it helps to set the tone for the whole lubrication program, changing the way mechanics, lubricators and operators think about lubrication.

Performance

For filtering mineral-based industrial oils and most synthetic oils with a maximum operating viscosity range of ISO VG 680 (3000ssu/648cSt) at 100°F/38°C within ambient temperature ranges of -15°F to 150°F (-26°C to 66°C)

Materials:

- Stand: Carbon steel
- Tank: HDPE or steel
- Paint: Industrial powder coat
- Filter Heads: Aluminum
- Fittings: Zinc-plated steel and/or brass
- Pumps: Aluminum/steel
- Hoses: Clear PVC with steel wire
- Gaskets: Buna-N

Filter Indicators:

- Filter indicator pops at 22psid (1.55bar) as warning that filter elements need to be replaced.

Pump Relief:

- Opens at 65psi (5.49bar)

Stacking Recommendations for HDPE Tanks:

- Stack tanks to a maximum height of 75" tall (including the stand, which is 20" tall).

Tank Dimensions:

80-gallon tank: 36"L x 36"W x 18"H

120-gallon tank: 36"L x 36"W x 27"H

180-gallon tank: 36"L x 36"W x 39"H

225-gallon tank: 36"L x 36"W x 49"H

Stacking Recommendations for Steel Tanks:

- 75-gallon tank: maximum of 3 stacked high
- 150-gallon tank: non-stackable
- 300-gallon tank: non-stackable

The Specs

By the Numbers

Item No.	Description	Qty.*
1	Spill Containment Pan (purchased separately)	1
2	Filter Element	3
3	Filter Head	3
4	Stand	1
5	Gear Pump	3
6	Motor	3
7	HDPE Tank	3
8	Tote Adapter	3
9	Drain Port	3
10	Fill Port	3
11	Desiccant Breather	3
12	Discharge Hose	3
13	Suction Hose	3

*For a 3-tank system configuration

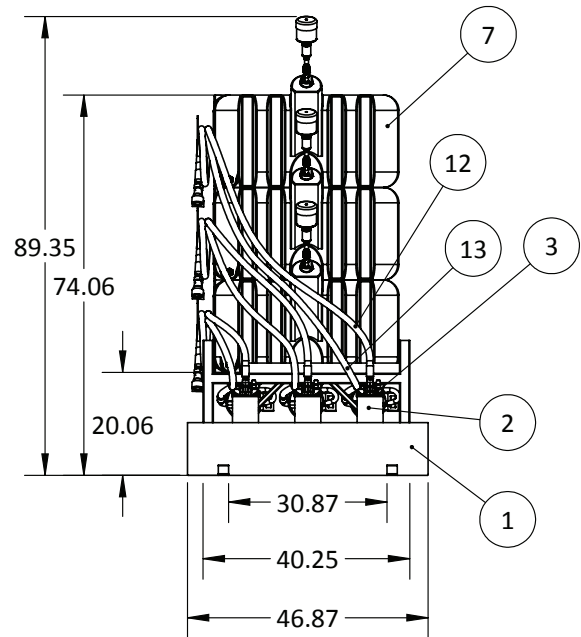

How to Size Spill Containment Pans:

- 110% of the volume of the largest container
Ex: For a 3-stackable 80-gallon HDPE tank system, use the 95-gallon containment pan.

Aluminum Spill Containments:

- "A" L x 46.20"W x 10.26"H

Spill Containment Size	"A" Dimension
95	46.87
135	66.62
200	98.62
265	130.62

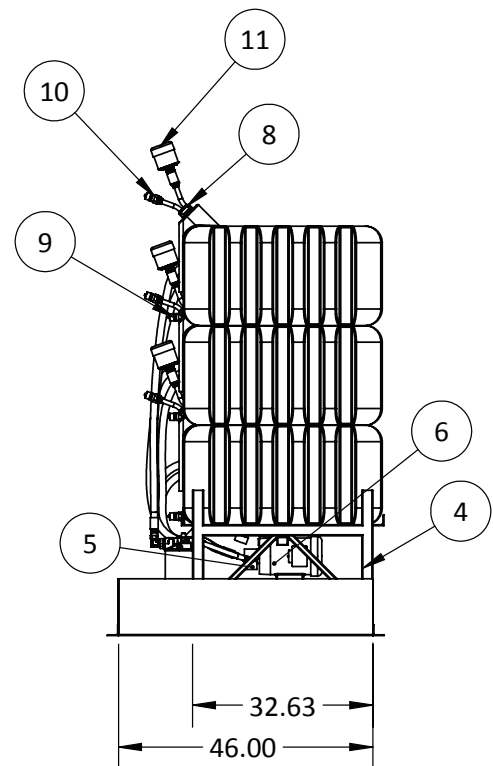
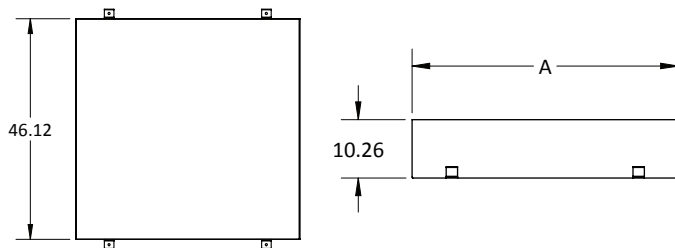

HDPE Spill Containment Pan:

- 203 gallon (for 80-gal and 120-gal options)
 58"L x 52"W x 20"H



TO ORDER:

LT-LMS

LT	C Upper Unit									
LT	B Middle Unit									
LT	A Lower Unit									
		Box 1	Box 2	Box 3	Box 4	Box 5	Box 6	Box 7	Box 8	Box 9



Tank Size [Box 2]

Code	Description
75	75-gallon tank (Steel only)
80	80-gallon tank (HDPE only)
120	120-gallon tank (HDPE only)
150	150-gallon tank (Steel only)
180	180-gallon tank (HDPE only)
240	225-gallon tank (HDPE only)
300	300-gallon tank (Steel only)

Pump/Motor Combinations [Box 3]

60 Hz Options		50 Hz Options	
Code	Description	Code	Description
O2E	2gpm/1 hp electric, 115 vac, 60 Hz, 1725 rpms, 13 amps	O2G	1.5gpm/1 hp electric, 110 vac, 50 Hz, 1425 rpms, 12.4 amps
O5E	5gpm/1 hp electric, 115 vac, 60 Hz, 1725 rpms, 13 amps	O5G	4gpm/1 hp electric, 110 vac, 50 Hz, 1425 rpms, 12.4 amps
10E*	10gpm/1 hp electric, 115 vac, 60 Hz, 1725 rpms, 13 amps	10G*	8gpm/1 hp electric, 110 vac, 50 Hz, 1425 rpms, 12.4 amps
O2F	2gpm/1 hp electric, 230 vac, 60 Hz, 1725 rpms, 6.5 amps	O2H	1.5gpm/1 hp electric, 220 vac, 50 Hz, 1425 rpms, 6.2 amps
O5F	5gpm/1 hp electric, 230 vac, 60 Hz, 1725 rpms, 6.5 amps	O5H	4gpm/1 hp electric, 220 vac, 50 Hz, 1425 rpms, 6.2 amps
10F*	10gpm/1 hp electric, 230 vac, 60 Hz, 1725 rpms, 6.5 amps	10H*	8gpm/1 hp electric, 220 vac, 50 Hz, 1425 rpms, 6.2 amps
Pneumatic Options		Pneumatic Options	
O2A	2gpm/1 hp air, 0-3000 rpms	O8A	8gpm/1 hp air, 0-3000 rpms

NOTE: Performance will vary depending on operating temperature, fluid type, and unit options. Call Des-Case for assistance in choosing a flow rate specific to your needs. 65psi pressure relief valve included.

*Not recommended for steel tanks.

Options 4 through 9 listed on reverse



TO ORDER:

LT-LMS

Drain & Fill Connector Type [Box 4]

Code	Description
B	ISO B Connector
A	ISO A Connector
F	Flush Face Connector
R	ISO B Connector-BSPP
Q	ISO A Connector-BSPP
P	Flush Face Connector-BSPP

NOTE: All connectors are coupler ends (female)

Filter Box [Box 6]

Code	Description
Large Filter	
A	3-micron Particulate Filter
B	6-micron Particulate Filter
C	12-micron Particulate Filter
D	25-micron Particulate Filter
J	Water Filter

Breather Filters [Box 9]

Code	Description
2*	3-micron particulate desiccant breather [DC-2]
3	3-micron particulate desiccant breather [DC-3]
4	3-micron particulate desiccant breather [DC-4]

*Standard

Replace Your Elements

Part No.	Micron Rating
FC-AF	Beta 200 @ 3um
FC-BF	Beta 200 @ 6um
FC-CF	Beta 200 @ 12um
FC-DF	Beta 200 @ 25um
FC-JF	Water Removal

NOTE: Other micron sizes available upon request.

Drain & Fill Sizing [Box 5]

Code	Description
1	Drain: 1" hose & connection Fill: 3/4" hose & connection
2	Drain: 3/4" hose & connection Fill: 1/2" hose & connection

NOTE: Units are built for optimum performance when using 1" (drain) and 3/4" (fill) connections. Decrease in performance may occur when selecting other size combinations. Hoses are 1" and 3/4" respectively, regardless of connection sizes.

Sample Valves [Box 7]

Code	Description
0	None
1	Standard Minimes
2	High Viscosity

Manual Gravity Drain [Box 8]

Code	Description
0	None
D	Gravity Drain

You also can customize your system online at www.descase.com.



FLUID HANDLING:

The Entire Des-Case Line

We offer a full range of fluid handling and filtration products in Portable Filtration, Dedicated Filtration, Water Removal, Lubricant Storage & Filtration, Filter Elements, and Adapter Kits to suit your needs.

**Customize your system today at
www.descase.com.**

**Des-Case Corporation | 675 N. Main St. | Goodlettsville, TN 37072
D: 615.672.8800 | F: 615. 672.0701 | descase.com**