

Section 4: Fasteners

Fasteners

T-Nuts **GoTo**

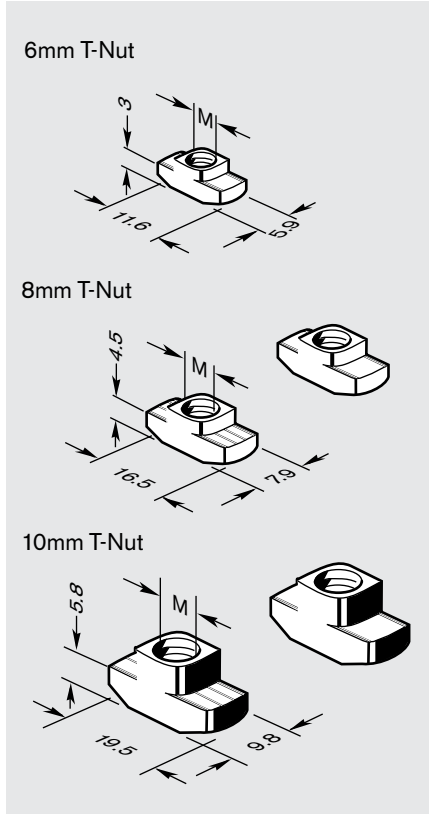

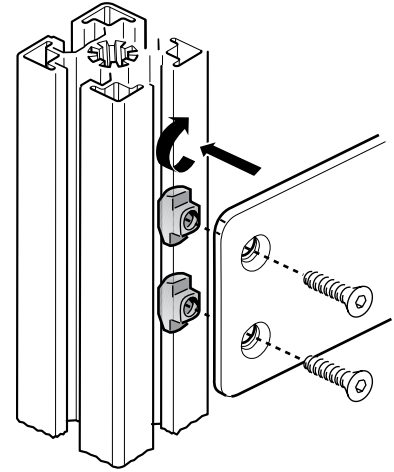

Features:

- Installs anywhere along the profile's T-slot and rotates into position
- Ridges "bite" into profile to lock the T-nut into position, and provide ESD protection and resistance to vibration
- Large contact surface improves gripping strength
- Tapered neck simplifies assembly; T-nut is self-aligning in T-slot
- M4 & M5 threads have 2 ridges
- M6 & M8 threads have 4 ridges
- 8-32 & 10-32 have 2 ridges
- 1/4" & 5/16" have 4 ridges



Material:

- Zinc-plated 8.8 steel (except as noted below)

Description	Tightening Torque (± 5%)	Lot Size	Part Number
6mm T-Nut 			
M4	2.5 Nm	1	3 842 523 135 <i>GoTo</i>
8mm T-Nuts 			
M4	2.5 Nm	1	3 842 501 751 <i>GoTo</i>
M5	5 Nm	1	3 842 501 752 <i>GoTo</i>
M6	10 Nm	1	3 842 501 753 <i>GoTo</i>
M6, nickel-plated	10 Nm	1	8 981 020 861
1/4"x20 U.N.C.	10 Nm	1	8 981 016 124
8-32 U.N.C.	10 Nm	1	8 981 016 122
10-32 U.N.F.	10 Nm	1	8 981 016 123
10mm T-Nuts			
M4	2.5 Nm	1	3 842 530 281 <i>GoTo</i>
M5	5 Nm	1	3 842 530 283 <i>GoTo</i>
M6	10 Nm	1	3 842 530 285 <i>GoTo</i>
M8	25 Nm	1	3 842 530 287 <i>GoTo</i>
M8, nickel-plated	25 Nm	1	8 981 019 580
1/4"x20 U.N.C.	10 Nm	1	8 981 021 323 <i>GoTo</i>
8-32 U.N.C.	10 Nm	1	8 981 021 321
10-32 U.N.F.	10 Nm	1	8 981 021 322
5/16"x18 U.N.C.	25 Nm	1	8 981 021 324 <i>GoTo</i>

Helpful Hint

Die-cast nut gives maximum material thickness for more thread engagement.

Tapered design is self-aligning and locks in T-slot.

Ridges bite through the anodized surface for the best possible ESD connection and vibration resistance.

