

# ACS850

## Hardware Manual

ACS850-04 Drive Modules (400 to 560 kW, 450 to 700 hp)



## List of related manuals

Manual	Code (English)
<b>STANDARD MANUALS</b>	
<i>ACS850-04 Hardware Manual 400 to 560 kW (450 to 700 hp)</i>	<a href="#">3AUA0000081249</a>
<i>ACS850 Standard Control Program Firmware Manual</i>	<a href="#">3AUA0000045497</a>
<i>ACS850 Quick Start-up Guide (Standard Control Program)</i>	<a href="#">3AUA0000045498</a>
<b>OPTION MANUALS</b>	
<i>ACS-CP-U Control Panel IP54 Mounting Platform Kit (+J410) Installation Guide</i>	<a href="#">3AUA0000049072</a>
Fieldbus Adapters, I/O Extension Modules etc.	

You can find manuals and other product documents in PDF format on the Internet. See section [Document library on the Internet](#) on the inside of the back cover. For manuals not available in the Document library, contact your local ABB representative.

ACS850-04 Drive Modules  
400 to 560 kW (450 to 700 hp)

**Hardware Manual**

3AUA0000081249 Rev A EN  
EFFECTIVE: 2011-03-11

© 2011 ABB Oy. All Rights Reserved.



# Update Notice

This notice concerns the following *ACS850-04 Hardware Manuals*:

Code	Revision	Language	
3AUA0000081249	A	English	EN
3AUA0000097784	A	Dansk	DA
3AUA0000097785	A	Deutsch	DE
3AUA0000097786	A	Español	ES
3AUA0000097787	A	Suomi	FI
3AUA0000097788	A	Français	FR
3AUA0000097789	A	Italiano	IT
3AUA0000097790	A	Nederlands	NL
3AUA0000097791	A	Português	PT
3AUA0000097792	A	Русский	RU
3AUA0000097793	A	Svenska	SV
3AUA0000097804	A	Türkçe	TR

**Code:** 3AUA0000102679 Rev A

**Valid:** From 29.6.2011 until the release of Rev B of the manual

**Contents:** Unpacking drawings for the additional boxes in the transport package of the drive module and installation instructions for the PE terminal, assembly support and grounding busbar.

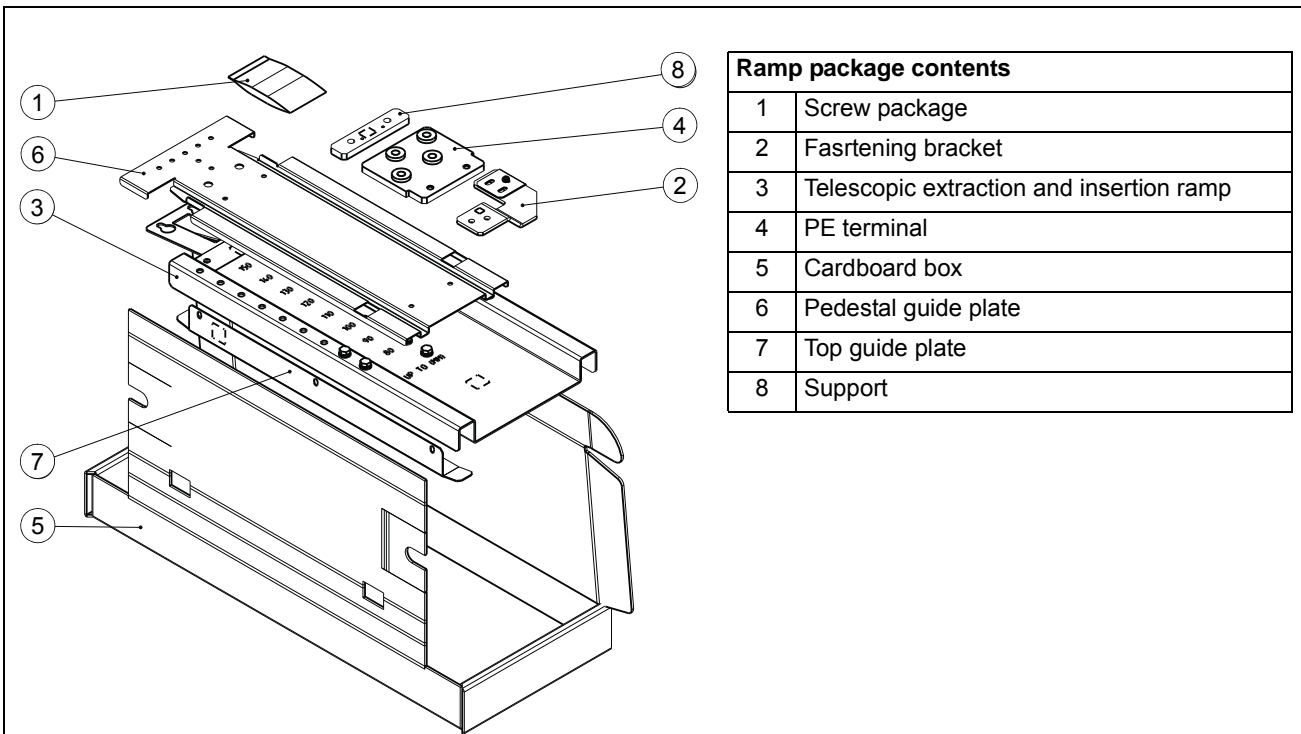

Ramp package contents	
1	Screw package
2	Fastening bracket
3	Telescopic extraction and insertion ramp
4	PE terminal
5	Cardboard box
6	Pedestal guide plate
7	Top guide plate
8	Support

Install the PE terminal (4) and assembly support (8) as shown below.

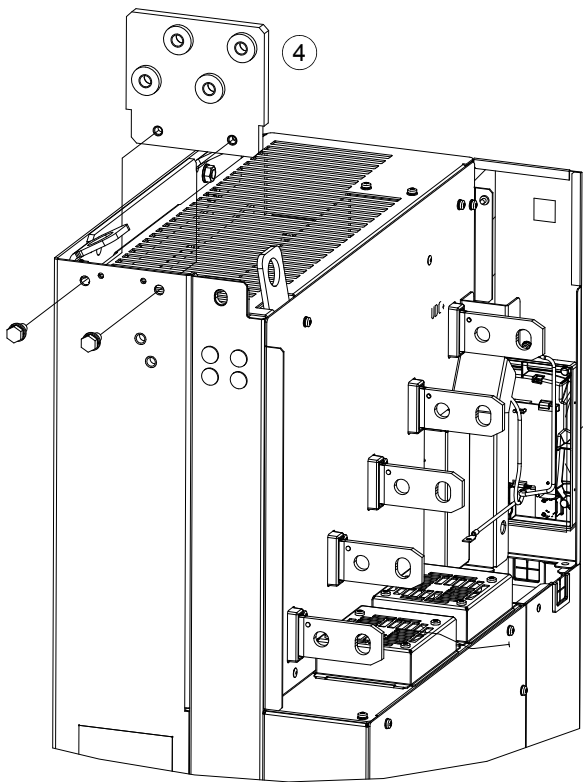

M8x16 Hex

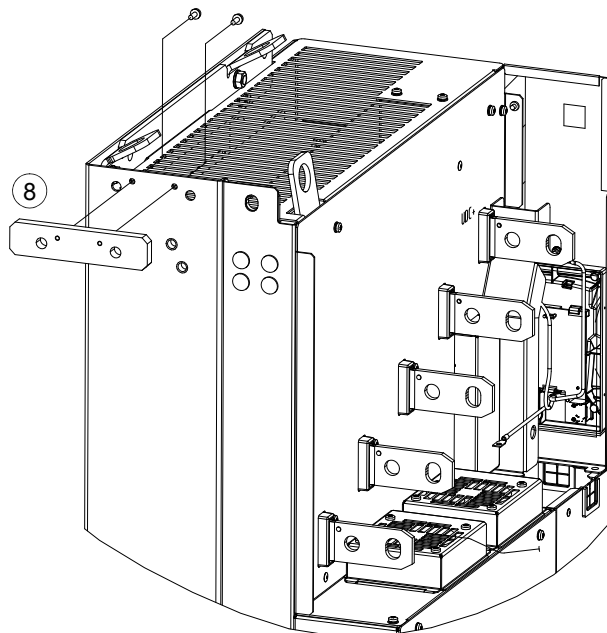

M4x12 Torx

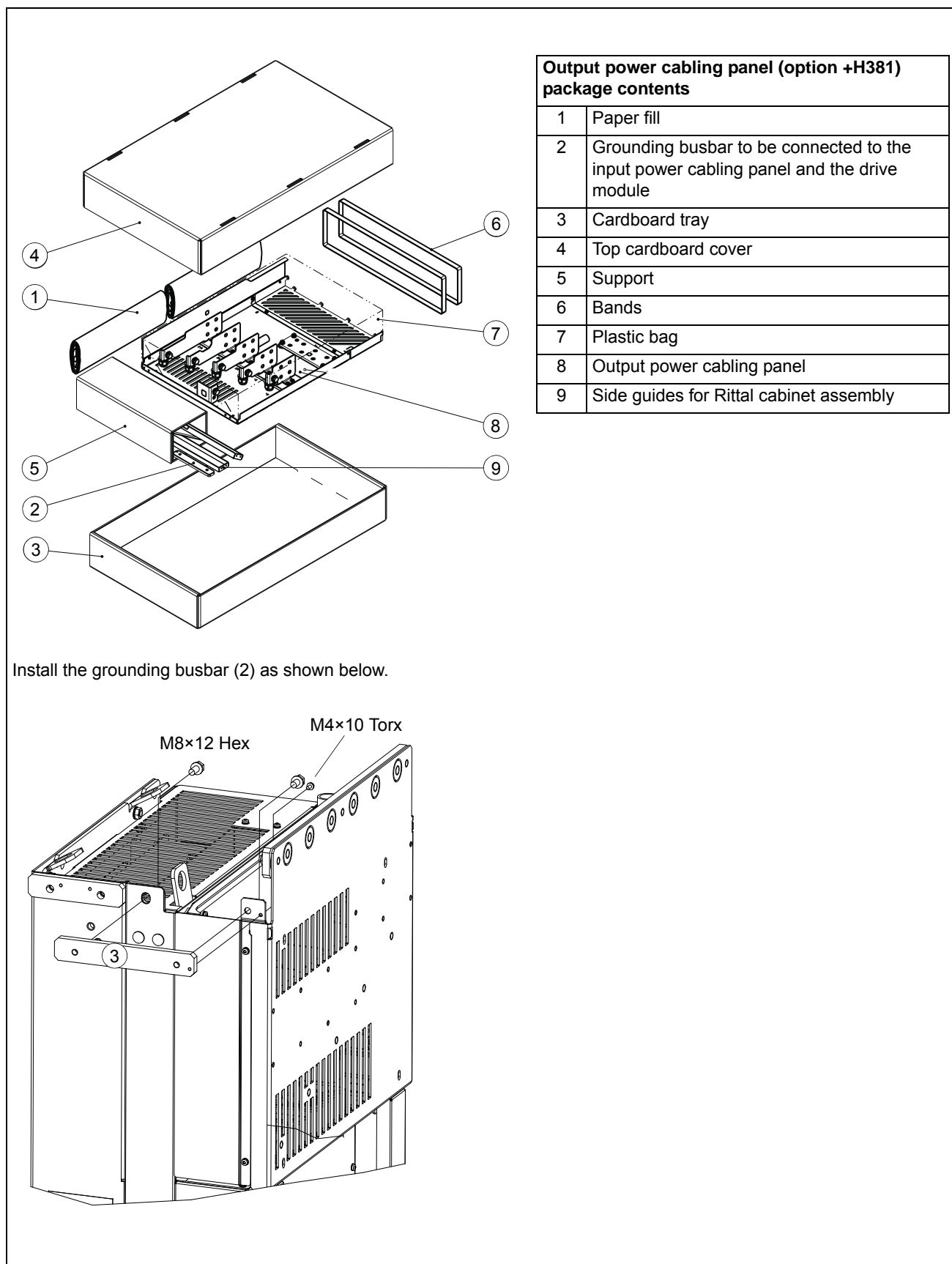

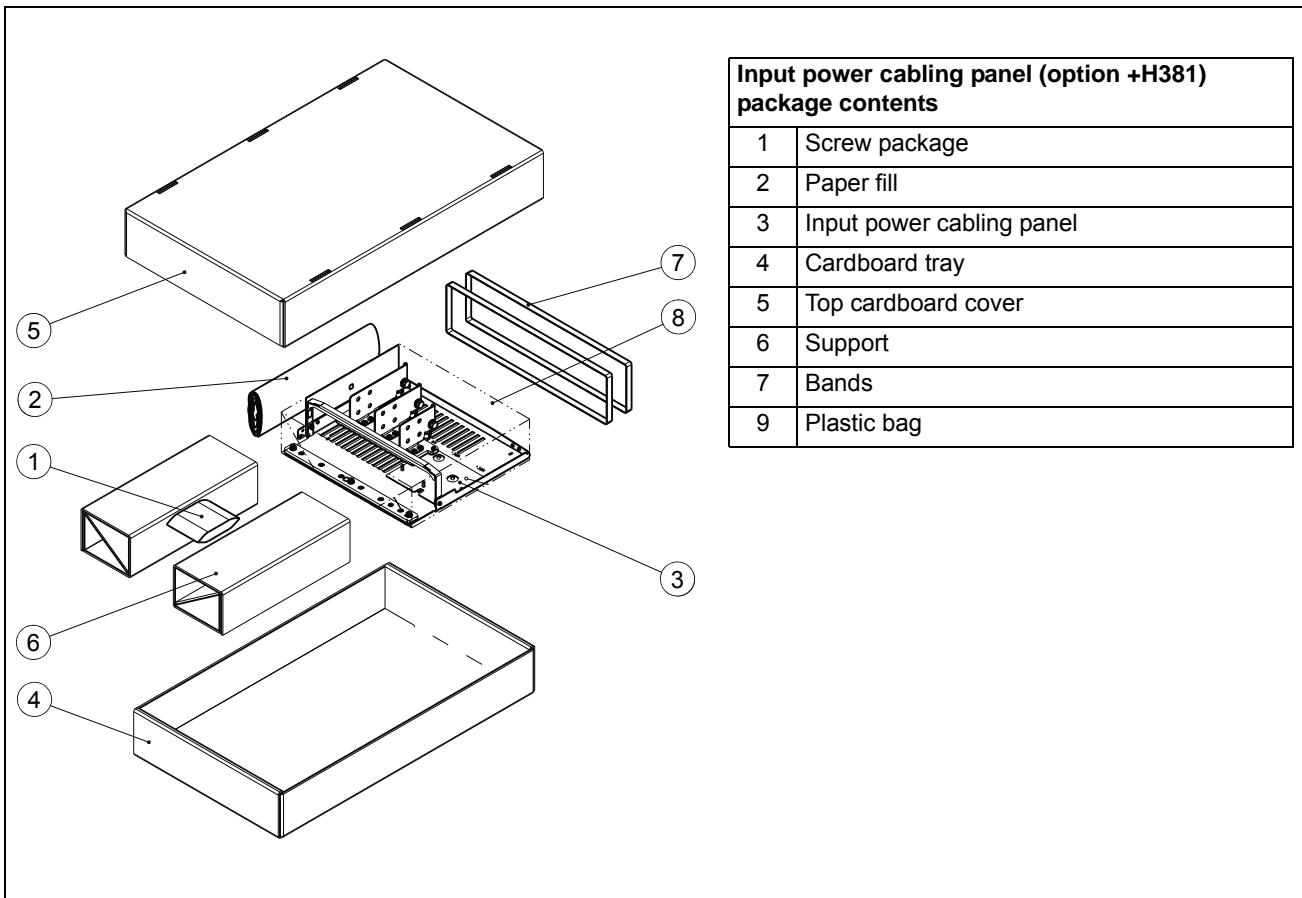

# Table of contents

---

List of related manuals .....	2
-------------------------------	---

## ***Table of contents***

### ***Safety instructions***

What this chapter contains .....	11
Use of warnings .....	11
Safety in installation and maintenance .....	12
Electrical safety .....	12
Grounding .....	13
Permanent magnet motor drives .....	14
General safety .....	15
Fiber optic cables .....	16
Printed circuit boards .....	17
Safe start-up and operation .....	17
General safety .....	17
Permanent magnet motor drives .....	17

### ***Introduction to the manual***

What this chapter contains .....	19
Target audience .....	19
Contents of the manual .....	19
Categorization by option code .....	20
Quick installation, commissioning and operating flowchart .....	20
Terms and abbreviations .....	22

### ***Operation principle and hardware description***

What this chapter contains .....	25
Product overview .....	25
Layout .....	26
Power connections and control interfaces .....	30
External control unit connection cables .....	31
Type designation label .....	31
Type designation key .....	32

### ***Planning the cabinet installation***

What this chapter contains .....	35
Basic requirements for the cabinet .....	35
Planning the layout of the cabinet .....	35
Layout examples, door closed .....	36
Layout examples, door open .....	37

Arranging the grounding inside the cabinet	38
Selecting the busbar material and preparation of the joints	38
Tightening torques	38
Planning the fastening of the cabinet	38
Planning the cabinet placement on a cable channel	39
Planning the electromagnetic compatibility (EMC) of the cabinet	39
Planning the grounding of the cable shields at the cabinet lead-through	41
Planning the cooling	41
Preventing the recirculation of hot air	43
Required free space	43
Free space at top with air inlet gratings in the cabinet door	44
Free space around the drive module	44
Other installation positions	44
Planning the placement of the control panel	44
Planning the use of the cubicle heaters	45

### ***Planning the electrical installation***

What this chapter contains	47
Selecting the supply disconnecting device (disconnecting means)	47
European Union	47
Other regions	47
Selecting and dimensioning the main contactor	47
Protecting the motor insulation and bearings	48
Checking the compatibility of the motor and drive	48
Requirements table	49
Explosion-safe (EX) motors	50
High-output motors and IP 23 motors	51
HXR and AMA motors	51
ABB motors of types other than M2_, M3_, HX_ and AM_	51
Resistor braking of the drive	51
Calculating the rise time and the peak line-to-line voltage	51
Sine filters	52
Common mode filters	52
Selecting the power cables	52
General rules	52
Typical power cable sizes	53
Typical power cable sizes (US)	54
Alternative power cable types	54
Motor cable shield	55
Additional US requirements	55
Conduit	55
Armored cable / shielded power cable	55
Selecting the control cables	56
Shielding	56
Signals in separate cables	56
Signals allowed to be run in the same cable	56
Relay cable type	56
Control panel cable length and type	56

Routing the cables	56
Separate control cable ducts	58
Continuous motor cable shield or enclosure for equipment in the motor cable	58
Implementing thermal overload and short-circuit protection	59
Protecting the drive and input power cable in short-circuits	59
Protecting the motor and motor cable in short-circuits	59
Protecting the drive and the input power and motor cables against thermal overload	60
Protecting the motor against thermal overload	60
Protecting the drive against ground faults	60
Residual current device compatibility	60
Implementing the Emergency stop function	61
Implementing the Safe torque off function	61
Implementing the ATEX-certified Safe motor disconnection function (option +Q971)	63
Implementing the Power loss ride-through function	63
Using power factor compensation capacitors with the drive	63
Implementing a safety switch between the drive and motor	64
Using a contactor between the drive and the motor	64
Implementing a bypass connection	64
Example bypass connection	65
Switching the motor power supply from drive to direct-on-line	66
Switching the motor power supply from direct-on-line to drive	66
Protecting the contacts of relay outputs	66
Connecting a motor temperature sensor to the drive I/O	67
Example circuit diagram	67

## ***Installation***

What this chapter contains	69
Safety	70
Checking the installation site	70
Required tools	70
Moving and unpacking the unit	71
Checking the delivery	72
Checking the insulation of the assembly	72
Drive	72
Input cable	72
Motor and motor cable	72
Brake resistor and resistor cable	73
Overall flowchart of the installation process	73
Installing the mechanical accessories into the cabinet	73
Connecting the power cables	75
Connection diagram	75
Input cable connection procedure	77
Motor cable connection procedure	78
DC connection	79
Mounting the drive module into the cabinet	80
Mounting procedure	80
Assembly drawing of fastening the drive module to the cabinet	82
Removing the protective covering from the module air outlet	83

Connecting the control cables .....	83
Flowchart of the control cable installation process (external control unit) .....	83
Flowchart of the control cable installation process (internal control unit, option +P905) .....	83
Removing the cover assembly of the external control unit .....	84
Fastening the control cable clamp plate .....	85
Connecting the external control unit to the drive module .....	85
Mounting the external control unit .....	87
Mounting the external control unit to wall .....	87
Mounting the external control unit vertically on a DIN rail .....	88
Mounting the control unit horizontally on a DIN rail .....	88
Installing optional modules .....	89
Mechanical installation .....	89
Wiring the modules .....	89
Connecting the control cables to the terminals of the control unit .....	90
Default I/O connection diagram .....	92
Jumpers .....	93
External power supply for the JCU Control Unit (XPOW) .....	94
DI6 (XDI:6) as a thermistor input .....	94
Drive-to-drive link (XD2D) .....	95
Safe torque off (XSTO) .....	96
Control cable connection procedure of units with internal control unit (option +P905) .....	96
Connecting a PC .....	97

### ***Installation checklist***

What this chapter contains .....	99
Installation checklist .....	99

### ***Start-up***

What this chapter contains .....	103
Start-up procedure .....	103

### ***Fault tracing***

What this chapter contains .....	105
LEDs .....	105
Warning and fault messages .....	105

### ***Maintenance***

What this chapter contains .....	107
Applicability .....	107
Maintenance intervals .....	107
Cabinet .....	108
Cleaning the interior of the cabinet .....	108
Heatsink .....	109
Cleaning the interior of the heatsink .....	109

Fans	110
Replacing the circuit board compartment cooling fan	110
Replacing the main cooling fans	111
Replacing the drive module	112
Capacitors	114
Reforming the capacitors	114
Memory unit	114

### **Technical data**

What this chapter contains	115
Ratings	115
Derating	115
Ambient temperature derating	116
Altitude derating	116
Fuses (IEC)	116
Ultrarapid (aR) fuses	116
Dimensions, weights and free space requirements	117
Losses, cooling data and noise	117
Terminal and lead-through data for the power cables	117
Units with optional common mode filter(+E208)	118
Units with optional cabling panels (+H381)	118
Terminal data for the control cables	118
Electrical power network specification	119
Motor connection data	119
Brake resistor connection data	119
DC connection data	119
Control unit (JCU-11) connection data	120
Efficiency	122
Degree of protection	122
Ambient conditions	122
Materials	123
Applicable standards	123
CE marking	124
Compliance with the European Low Voltage Directive	124
Compliance with the European EMC Directive	124
Compliance with the European Machinery Directive	124
Compliance with the EN 61800-3:2004	124
Definitions	124
Category C3	124
Category C4	125

### **Dimension drawings**

What this chapter contains	127
Drive module dimensions	128
Drive module dimensions with optional cabling panels (+H381)	129
Cabling panels (option +H381) installed into a Rittal TS 8 cabinet	131

**Example circuit diagrams**

What this chapter contains .....	133
Example circuit diagram .....	134

**Resistor braking**

What this chapter contains .....	135
Availability of brake choppers and resistors .....	135
When is resistor braking needed .....	135
Operation principle .....	135
Hardware description .....	135
Planning the braking system .....	135
Selecting the brake circuit components .....	135
Placing the brake resistors .....	136
Protecting the system in fault situations .....	137
Thermal overload protection .....	137
Short-circuit protection .....	137
Selecting and routing the brake circuit cables .....	137
Minimizing electromagnetic interference .....	137
Maximum cable length .....	138
EMC compliance of the complete installation .....	138
Mechanical installation .....	138
Electrical installation .....	138
Brake circuit commissioning .....	138
Technical data .....	139
Ratings .....	139
Brake resistor connection data .....	139
SAFUR resistors .....	139
Maximum resistor cable length .....	139
Dimensions and weights .....	140

**du/dt filters**

What this chapter contains .....	141
du/dt filters .....	141
When is du/dt filter needed? .....	141
Selection table .....	141
Description, installation and technical data of the FOCH filters .....	141

**Further information**

Product and service inquiries .....	143
Product training .....	143
Providing feedback on ABB Drives manuals .....	143
Document library on the Internet .....	143

# Safety instructions

---

## What this chapter contains

This chapter contains the safety instructions which you must follow when installing, operating and servicing the drive. If ignored, physical injury or death may follow, or damage may occur to the drive, motor or driven equipment. Read the safety instructions before you work on the unit.

## Use of warnings

Warnings caution you about conditions which can result in serious injury or death and/or damage to the equipment and advise on how to avoid the danger. The following warning symbols are used in this manual:



**Electricity warning** warns of hazards from electricity which can cause physical injury and/or damage to the equipment.



**General warning** warns about conditions, other than those caused by electricity which can result in physical injury and/or damage to the equipment.



**Electrostatic sensitive devices warning** warns of electrostatic discharge which can damage the equipment.



**Hot surface warning** warns of component surfaces that may become hot enough to cause burns if touched.

## Safety in installation and maintenance

### Electrical safety

These warnings are intended for all who work on the drive, motor cable or motor.



**WARNING!** Ignoring the following instructions can cause physical injury or death, or damage to the equipment:

- **Only qualified electricians are allowed to install and maintain the drive.**
- Never work on the drive, motor cable or motor when main power is applied. After disconnecting the input power, always wait for 5 min to let the intermediate circuit capacitors discharge before you start working on the drive, motor or motor cable.

Always ensure by measuring with a multimeter (impedance at least 1 Mohm) that:

1. voltage between drive input phases U1, V1 and W1 and the frame is close to 0 V.
  2. voltage between terminals UDC+ and UDC- and the frame is close to 0 V.
- Do not work on the control cables when power is applied to the drive or to the external control circuits. Externally supplied control circuits may cause dangerous voltages inside the drive even when the main power on the drive is switched off.
  - Do not make any insulation or voltage withstand tests on the drive or drive modules.

#### Note:

- The motor cable terminals on the drive are at a dangerously high voltage when the input power is on, regardless of whether the motor is running or not.
- The brake control terminals (UDC+, UDC-, R+ and R- terminals) carry a dangerous DC voltage (over 500 V).
- Depending on the external wiring, dangerous voltages (115 V, 220 V or 230 V) may be present on the terminals of relay outputs (X2) or Safe torque off (X6).
- The Safe torque off function does not remove the voltage from the main and auxiliary circuits.

## Grounding

These instructions are intended for all who are responsible for the grounding of the drive.



---

**WARNING!** Ignoring the following instructions can cause physical injury, death, increased electromagnetic interference and equipment malfunction:

- Ground the drive, motor and adjoining equipment to ensure personnel safety in all circumstances, and to reduce electromagnetic emission and interference.
- Make sure that grounding conductors are adequately sized as required by safety regulations.
- In a multiple-drive installation, connect each drive separately to protective earth (PE).
- Where EMC emissions must be minimized, make a 360° high frequency grounding of cable entries at the cabinet lead-through in order to suppress electromagnetic disturbances. In addition, connect the cable shields to protective earth (PE) in order to meet safety regulations.

---

**Note:**

- Power cable shields are suitable for equipment grounding conductors only when adequately sized to meet safety regulations.
- As the normal leakage current of the drive is higher than 3.5 mA AC or 10 mA DC, a fixed protective earth connection is required by EN 50178, 5.2.11.1.

### *Permanent magnet motor drives*

These are additional warnings concerning permanent magnet motor drives.

---



**WARNING!** Ignoring the instructions can cause physical injury or death, or damage to the equipment.

- Do not work on the drive when the permanent magnet motor is rotating. Also, when the supply power is switched off and the inverter is stopped, a rotating permanent magnet motor feeds power to the intermediate circuit of the drive and the supply connections become live.

Before installation and maintenance work on the drive:

- Stop the motor.
  - Ensure that there is no voltage on the drive power terminals according to step 1 or 2, or if possible, according to the both steps.
1. Disconnect the motor from the drive with a safety switch or by other means. Measure that there is no voltage present on the drive input or output terminals (U1, V1, W1, U2, V2, W2, UDC+, UDC-).
  2. Ensure that the motor cannot rotate during work. Make sure that no other system, like hydraulic crawling drives, is able to rotate the motor directly or through any mechanical connection like felt, nip, rope, etc. Measure that there is no voltage present on the drive input or output terminals (U1, V1, W1, U2, V2, W2, UDC+, UDC-). Ground the drive output terminals temporarily by connecting them together as well as to the PE.
-

## General safety

These instructions are intended for all who install and service the drive.



**WARNING!** Ignoring the following instructions can cause physical injury or death, or damage to the equipment:

- Lift the drive module using the lifting lugs attached to the top and base of the unit.

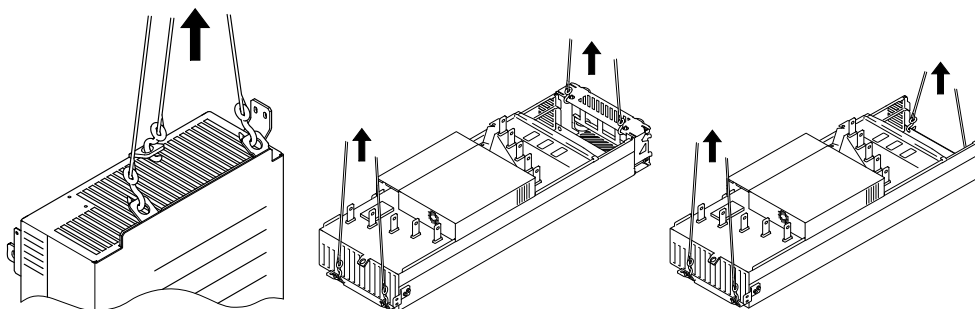

- Handle the drive module carefully. Make sure that the module does not fall down when moving it on the floor and during installation and maintenance work: Open the support legs by pressing each leg a little down (1, 2) and turning it aside. When ever possible secure the module also with chains.
- Do not tilt the drive module (A). It is **heavy** (over 200 kg [440 lb]) and its **center of gravity is high**. The module will overturn from a sideways tilt of 5 degrees. Do not leave the module unattended on a sloping floor.

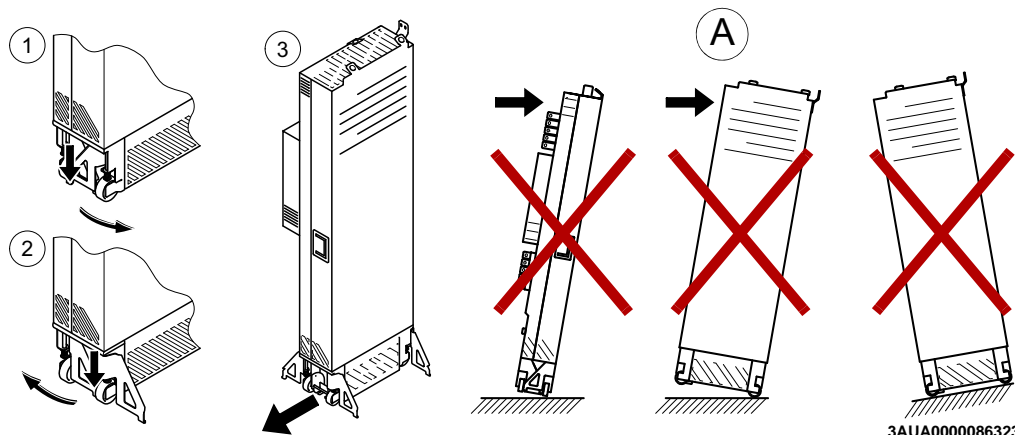

3AUA0000086323

- Push the drive module into the cabinet and pull it from the cabinet carefully preferably with help from another person as shown below. Keep a constant pressure with one foot on the base of the module to prevent the module from falling on its back. Use safety shoes with metal toe cap to avoid foot injury. Do not use the ramp with plinth heights which exceed the maximum height marked on the ramp next to the fastening screw. (The maximum plinth height is 50 mm when the telescopic ramp is shortest and 150 mm when the ramp is longest.) Tighten the two fastening bolts of the ramp carefully.

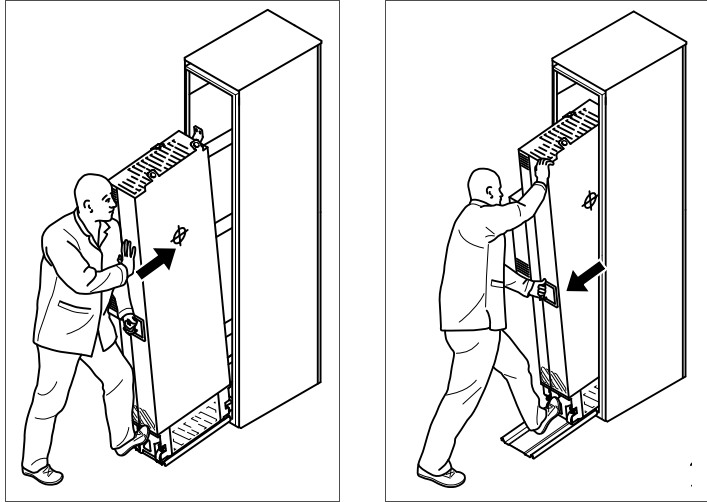

3AUA0000086323

- Beware of hot surfaces. Some parts, such as heatsinks of power semiconductors, remain hot for a while after disconnection of the electrical supply.
- Make sure that dust from borings and grindings does not enter the drive when installing. Electrically conductive dust inside the unit may cause damage or malfunctioning.
- Ensure sufficient cooling.
- Do not fasten the drive by riveting or welding.

---

#### *Fiber optic cables*



**WARNING!** Ignoring the following instructions can cause equipment malfunction and damage to the fiber optic cables:

- Handle the fiber optic cables with care. When unplugging optic cables, always grab the connector, not the cable itself. Do not touch the ends of the fibers with bare hands as the fiber is extremely sensitive to dirt. The minimum allowed bend radius is 35 mm (1.4 in.).
-

### Printed circuit boards



**WARNING!** Ignoring the following instructions can cause damage to the printed circuit boards:

- Wear a grounding wrist band when handling the boards. Do not touch the boards unnecessarily. The printed circuit boards contain components sensitive to electrostatic discharge.



## Safe start-up and operation

### General safety

These warnings are intended for all who plan the operation of the drive or operate the drive.



**WARNING!** Ignoring the following instructions can cause physical injury or death, or damage to the equipment:

- Before adjusting the drive and putting it into service, make sure that the motor and all driven equipment are suitable for operation throughout the speed range provided by the drive. The drive can be adjusted to operate the motor at speeds above and below the speed provided by connecting the motor directly to the power line.
- Do not activate any automatic fault reset functions of the drive control program if dangerous situations can occur. When activated, these functions will reset the drive and resume operation after a fault.
- Do not control the motor with an AC contactor or disconnecting device (disconnecting means); instead, use the control panel keys  and , or commands via the I/O board of the drive. The maximum allowed number of charging cycles of the DC capacitors, ie, power-ups by applying power, is five in ten minutes.

#### Note:

- If an external source for start command is selected and it is ON, the drive will start immediately after an input voltage break or fault reset unless the drive is configured for 3-wire (a pulse) start/stop.
- When the control location is not set to local, the stop key on the control panel will not stop the drive.

### Permanent magnet motor drives



**WARNING!** Do not run the motor over the rated speed. Motor overspeed leads to overvoltage which may damage or explode the capacitors in the intermediate circuit of the drive.



# Introduction to the manual

---

## What this chapter contains

This chapter describes the intended audience and contents of the manual. It contains a flowchart of steps in checking the delivery, installing and commissioning the drive. The flowchart refers to chapters/sections in this manual and other manuals.

## Target audience

This manual is intended for persons who

- plan the cabinet assembly of the drive module and install the module into a user-defined cabinet
- plan the electrical installation of the drive cabinet
- make instructions for the end user of the drive concerning the mechanical installation of the drive cabinet, connection of power and control cables to the cabinet-installed drive and maintenance of the drive.

Read the manual before working on the drive. You are expected to know the fundamentals of electricity, wiring, electrical components and electrical schematic symbols.

The manual is written for readers worldwide. Both SI and imperial units are shown.

## Contents of the manual

This manual contains the instructions and information for the basic drive module configuration. The chapters of the manual are briefly described below.

*Safety instructions* give safety instructions for the installation, commissioning, operation and maintenance of the drive module.

*Introduction to the manual* introduces the manual.

*Operation principle and hardware description* describes the drive module.

*Planning the cabinet installation* guides in planning drive cabinets and installing the drive module into a user-defined cabinet. The chapter gives cabinet layout examples and free space requirements around the module for cooling.

*Planning the electrical installation* instructs in the motor and cable selection, protections and cable routing.

*Installation* describes how to install the drive module into a cabinet and connect the cables to the drive.

*Installation checklist* contains lists for checking the mechanical and electrical installation of the drive.

*Start-up* refers to the start-up instructions of the cabinet-installed drive.

*Fault tracing* describes the LED indications and refers to the fault tracing instructions of the drive.

*Maintenance* contains preventive maintenance instructions.

*Technical data* contains the technical specifications of the drive module, eg, the ratings, sizes and technical requirements, provisions for fulfilling the requirements for CE and other markings.

*Dimension drawings* contains dimension drawings of the drive module installed into a Rittal TS 8 cabinet.

*Example circuit diagram* shows an example circuit diagram for a cabinet-installed drive module.

*Resistor braking* describes how to select, protect and wire brake resistors.

*du/dt filters* describes how to select du/dt filters for the drive.

## Categorization by option code

The instructions and technical data which concern only certain optional selections are marked with option codes, eg, +H381. The options included in the drive can be identified from the option codes visible on the type designation label. The option selections are listed in section *Type designation key* on page 32.

## Quick installation, commissioning and operating flowchart

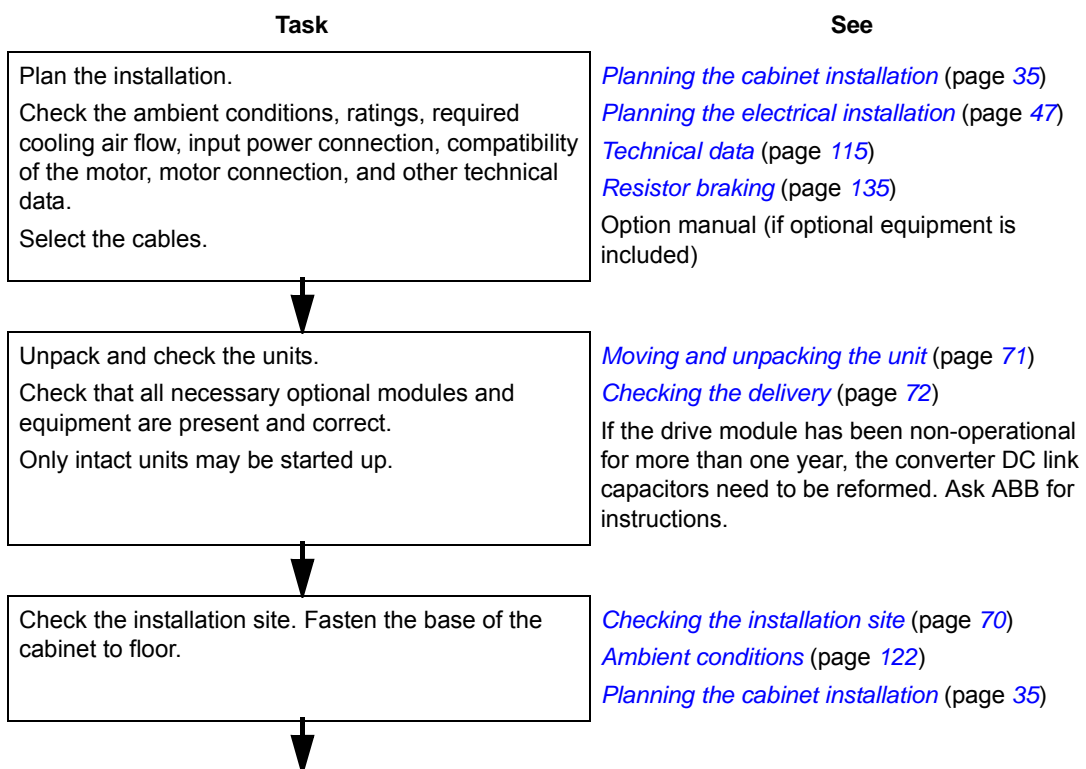

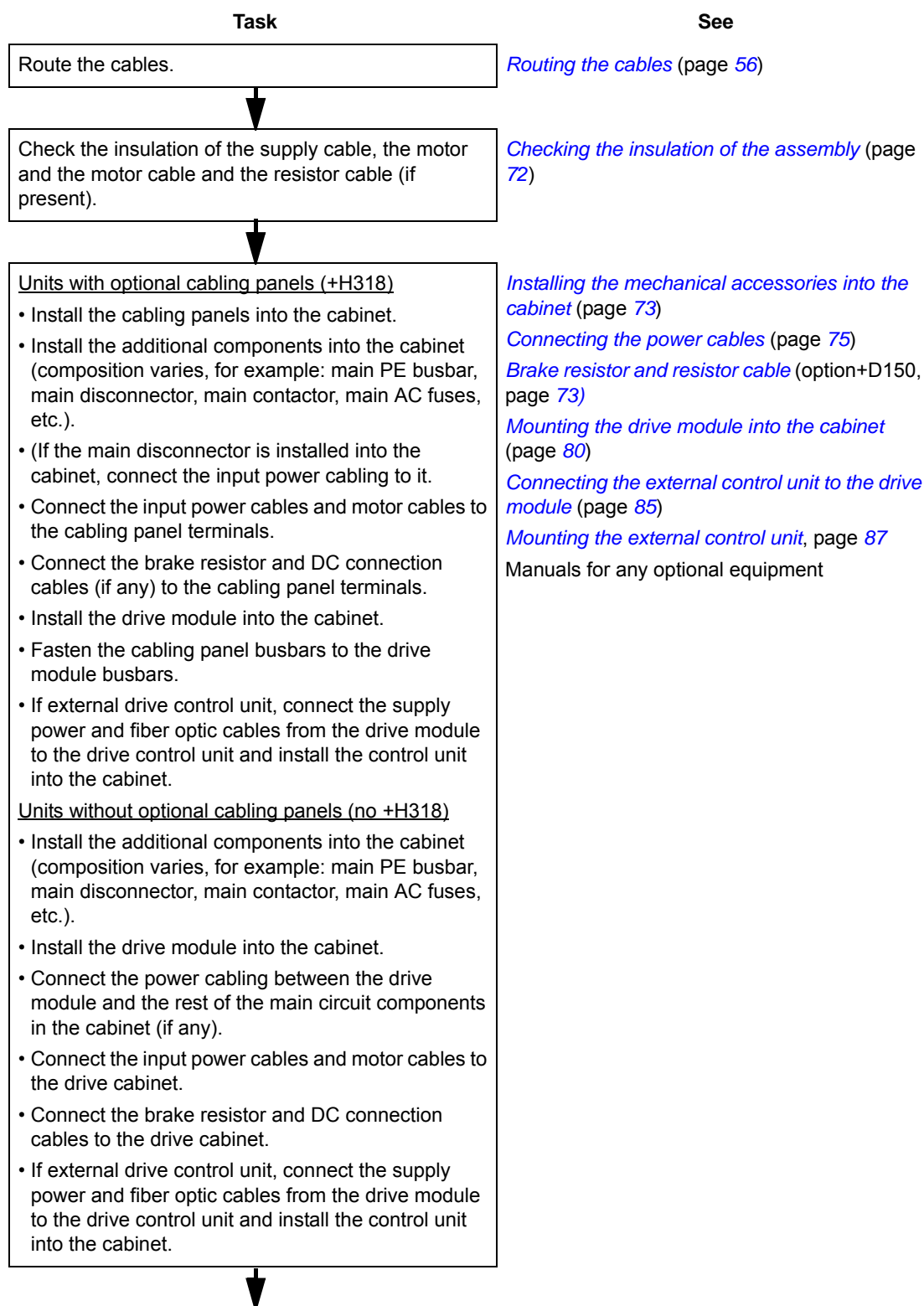

Task	See
Connect the external control cables to the drive control unit.	<a href="#">Connecting the control cables</a> (page 83) <a href="#">Control cable connection procedure of units with internal control unit (option +P905)</a> , page 96
↓	
Check the installation.	<a href="#">Installation checklist</a> (page 99)
↓	
Commission the drive.	<a href="#">Start-up</a> (page 103)
↓	
Commission the brake chopper (if used).	<a href="#">Resistor braking</a> (page 135)
↓	
Operating of the drive: start, stop, speed control etc.	Appropriate <i>Firmware Manual</i>

## Terms and abbreviations

Term/Abbreviation	Explanation
APOW	Power supply board
BFPS	Power supply board
EMC	Electromagnetic compatibility
EMI	Electromagnetic interference
FCAN-0x	Optional CANopen adapter module
FDNA-0x	Optional DeviceNet™ adapter module
FECA-01	Optional EtherCAT® adapter module
FEN-01	Optional TTL encoder interface module
FEN-11	Optional absolute encoder interface module
FEN-21	Optional resolver interface module
FENA-0x	Optional Ethernet/IP™ adapter module
FIO-01	Optional digital I/O extension module
FIO-11	Optional analog I/O extension module
FIO-21	Optional analog and digital I/O extension module
FLON-0x	Optional LonWorks® adapter module
FPBA-0x	Optional PROFIBUS DP adapter module
Frame (size)	Size of the drive module. The drive modules described in this manual are of frame size G2.
FSCA-0x	Optional Modbus adapter v

HTL	High-threshold logic
IGBT	Insulated gate bipolar transistor; a voltage-controlled semiconductor type widely used in inverters due to their easy controllability and high switching frequency.
I/O	Input/Output
JCU	The control unit of the drive module. The external I/O control signals are connected to the JCU, or optional I/O extensions mounted on it.
JGDR	Gate driver board
JINT	Main circuit board
JMU-xx	The memory unit attached to the control unit of the drive
JRIB	Adapter board connected to the control board in the control unit (JCU)
RFI	Radio-frequency interference
TTL	Transistor-transistor logic



# Operation principle and hardware description

## What this chapter contains

This chapter describes the operating principle and construction of the drive module in short.

## Product overview

The ACS850-04 is a drive module for controlling asynchronous AC induction motors and permanent magnet synchronous motors.

The main circuit of the drive module is shown below.

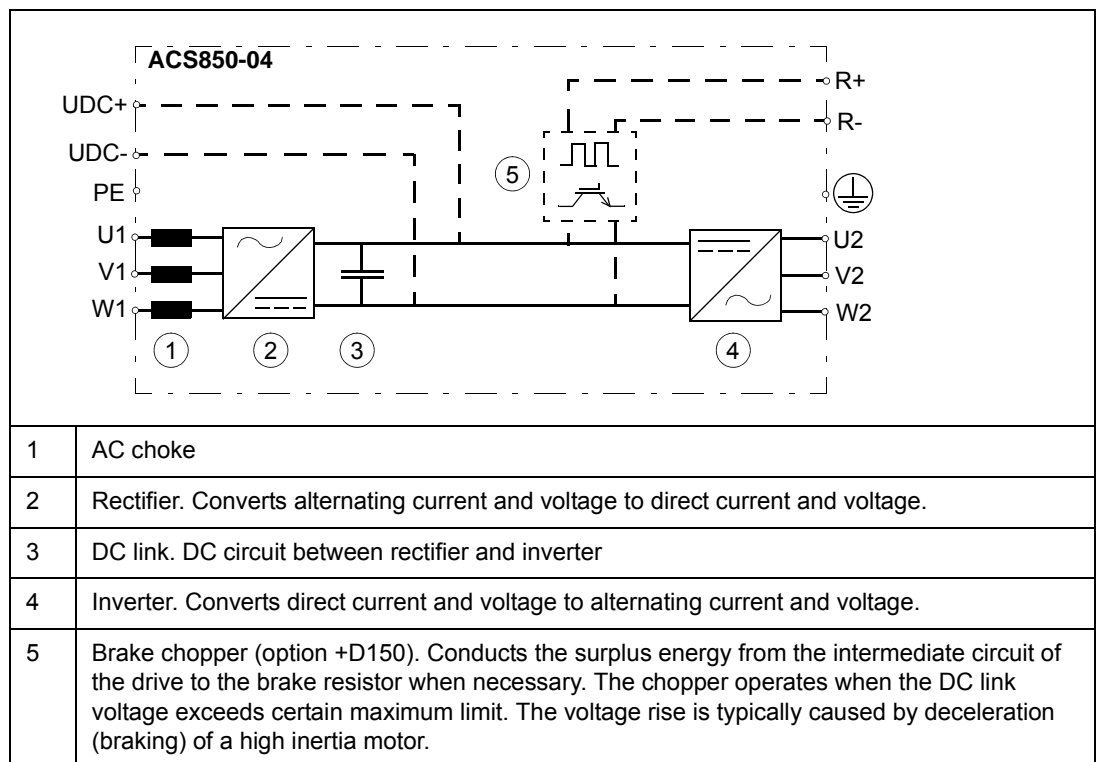

**Layout**

The components of the standard unit are shown below.

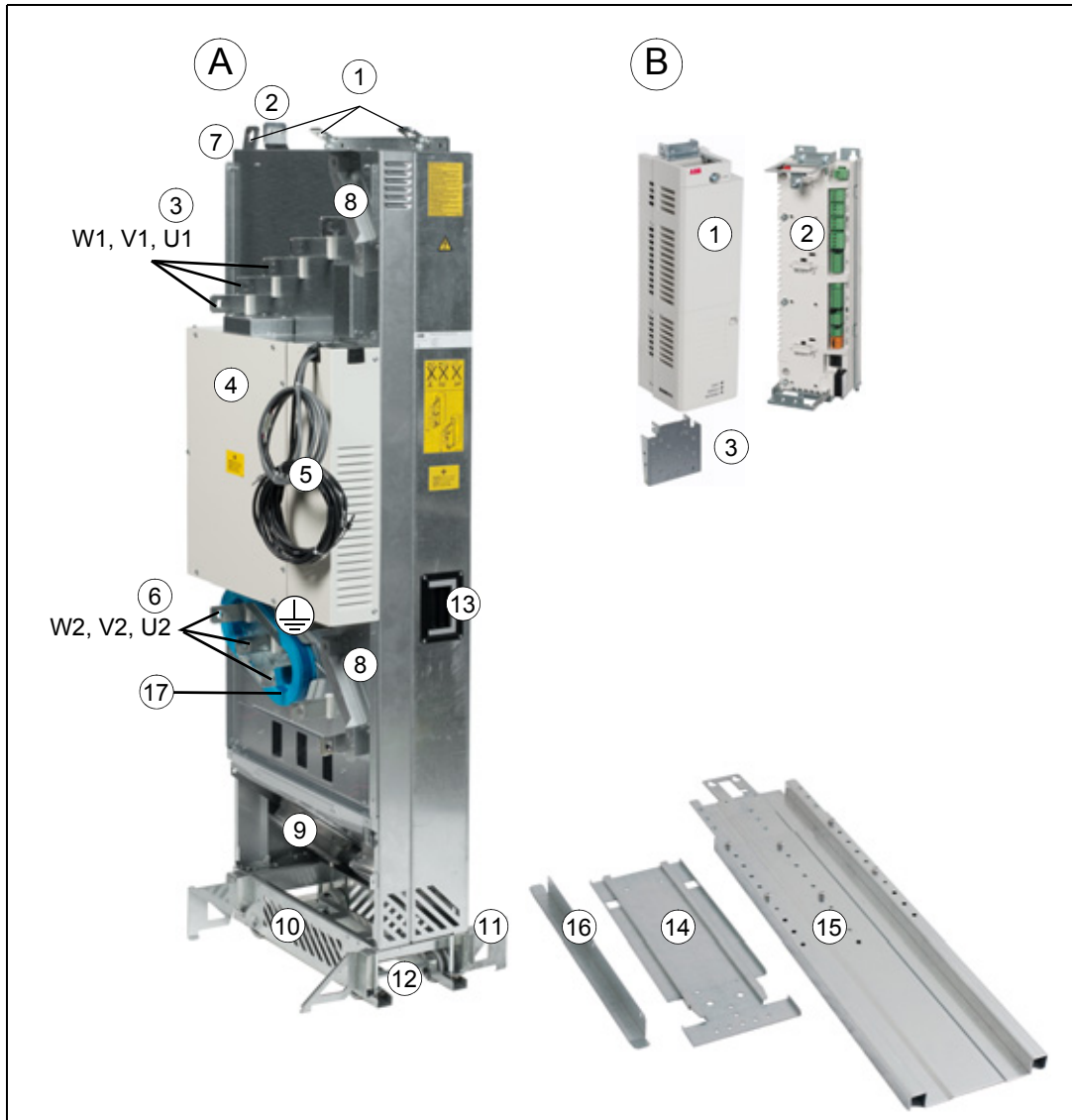

Item	Description
<b>A</b>	<b>Drive module</b>
1	Lifting lugs
2	Fastening bracket
3	Input cable connection busbars and optional DC+ and DC- busbars (+H356)
4	Circuit board compartment
5	Power supply and fiber optic cables to be connected to the external control unit
6	Output cable connection busbars and optional brake resistor connection busbars (+D150)
7	PE terminal
8	Control cable duct
9	Main cooling fans
10	Pedestal
11	Retractable support legs

<b>Item</b>	<b>Description</b>
12	Base fastening screws
13	Handle for pulling the drive module out of the cabinet
14	Pedestal guide plate
15	Telescopic extraction and insertion ramp
16	Top guide plate
17	Optional common mode filter (+E208)
<b>B</b>	<b>Control unit (JCU)</b>
1	Control unit with front cover
2	Control unit with front cover removed
3	Control cable clamp plate

The drive module and optional selections are shown below: control unit and control panel variations and cabling panels.

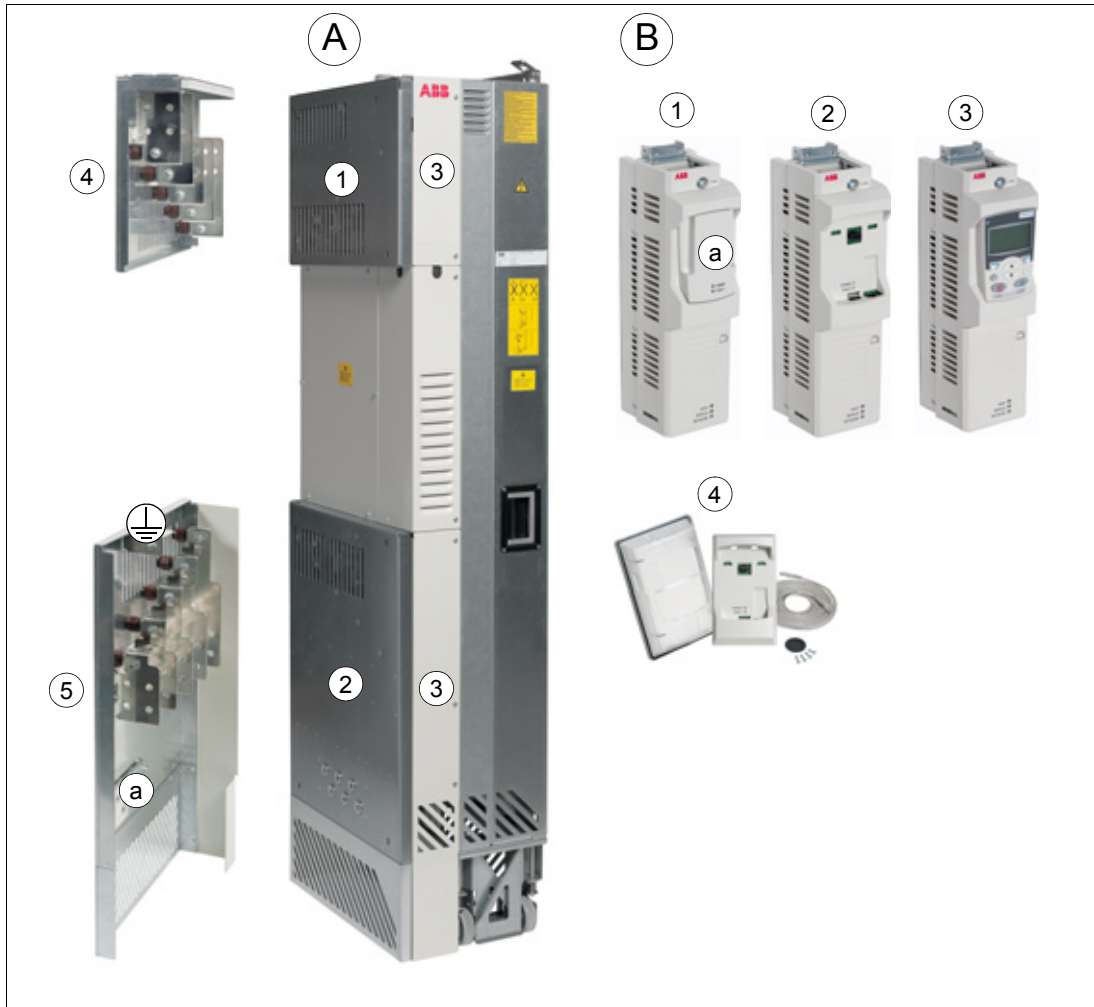

Item	Description
<b>A</b>	<b>Drive module</b>
1	Input power cabling panel fastened to the drive module
2	Output power cabling panel fastened to the drive module
3	Front cover. With option +P905, the control panel is placed on this cover.
4	Input power cabling panel (+H381)
5	Output power cabling panel (+H381). a) Grounding terminal.
<b>B</b>	<b>Control unit variants</b>
1	Control unit with control panel holder (+J414)
2	Control unit with control panel holder (+J414) when cover (a) is removed
3	Control unit with control panel (+J400)
4	Control panel door mounting kit (+J410)

The control unit layout is shown below (cover assembly and protective coverings of the slots removed).

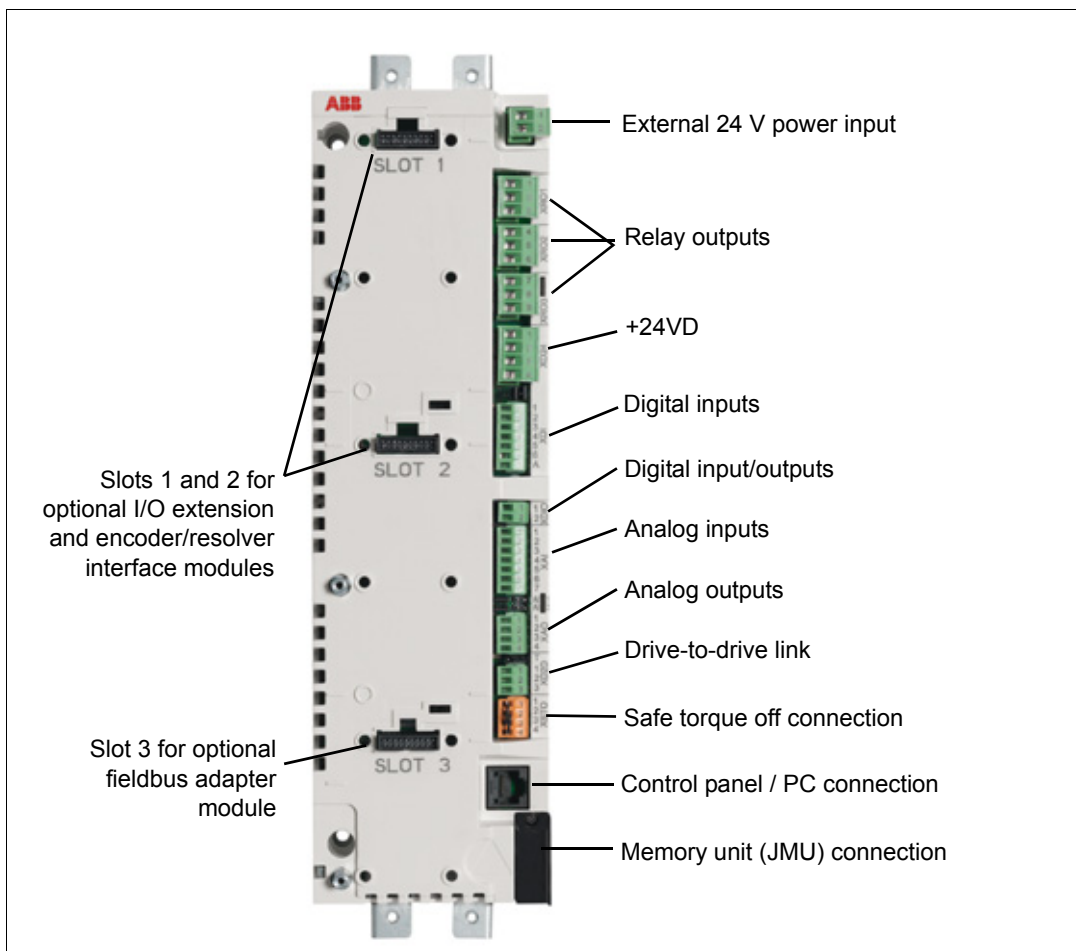

### Power connections and control interfaces

The diagram shows the power connections and control interfaces of the drive module.

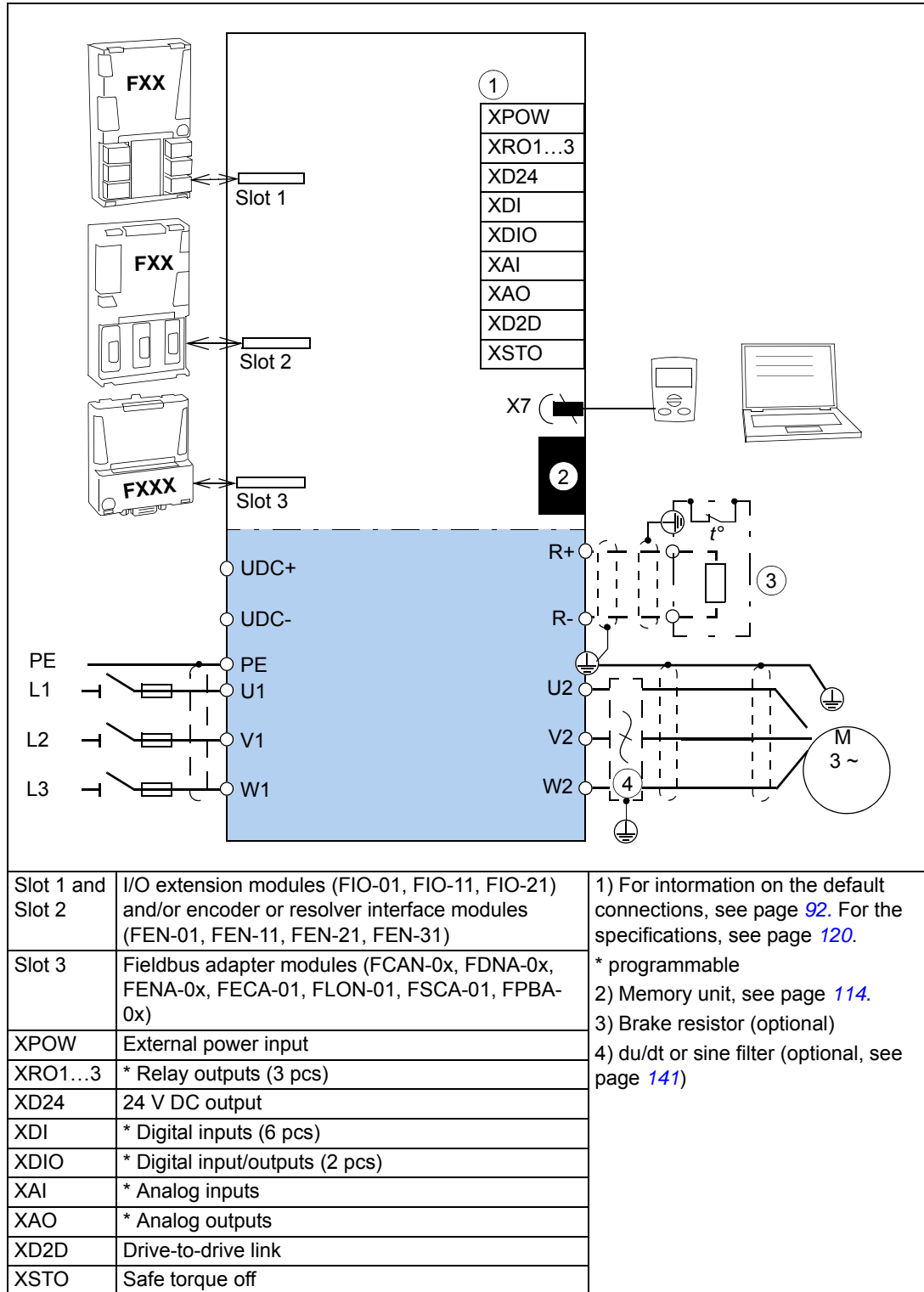

## External control unit connection cables

The cables for connecting the drive module and control panel to the control unit are shown below. See sections [Connecting the external control unit to the drive module](#) (page 85) and [Connecting a PC](#) (page 97) for the actual connections.

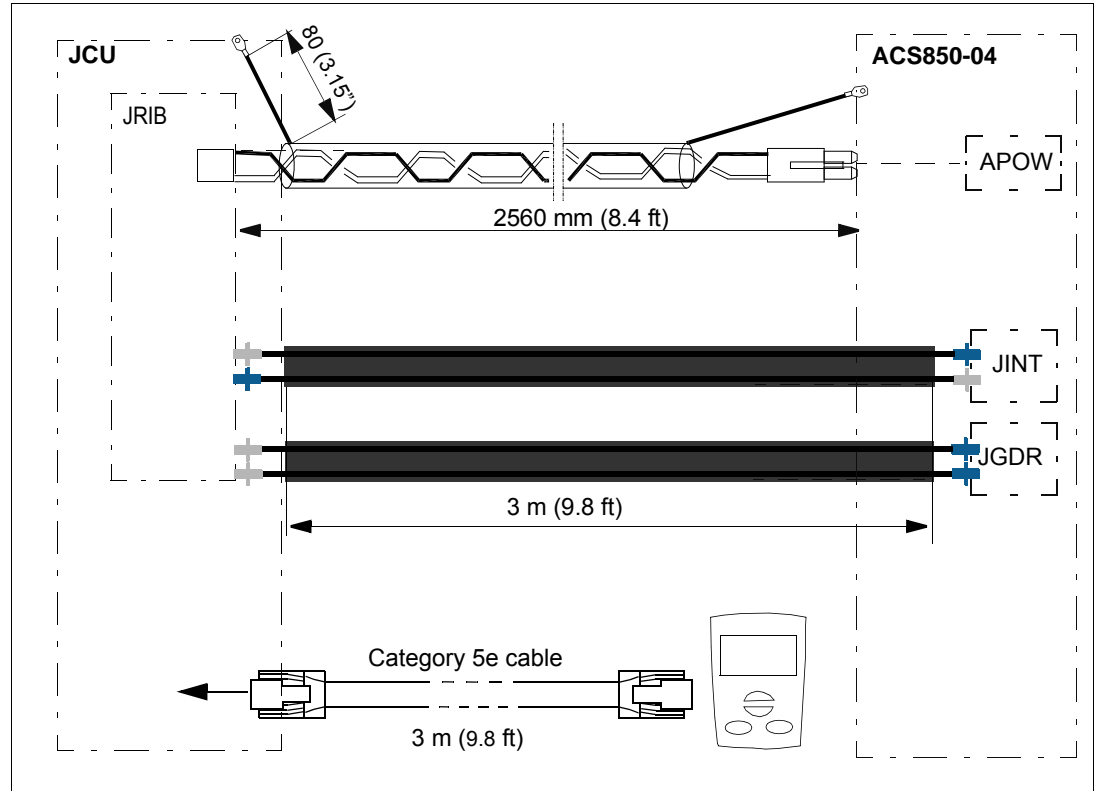

## Type designation label

The type designation label includes an IEC and NEMA rating, CE, C-UL US, and CSA markings, a type designation and a serial number, which allow individual recognition of each unit. The type designation label is located on the front cover. An example label is shown below.

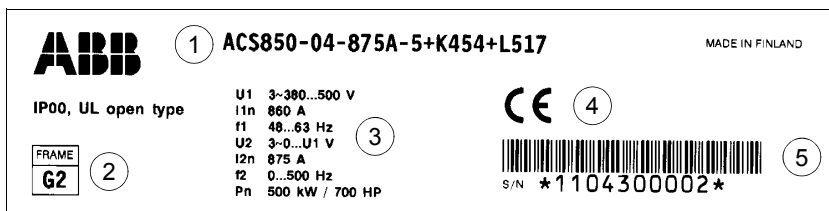

No.	Description
1	Type designation, see section <a href="#">Type designation key</a> on page 32.
2	Frame size
3	Ratings
4	Valid markings
5	Serial number. The first digit of the serial number refers to the manufacturing plant. The next four digits refer to the unit's manufacturing year and week, respectively. The remaining digits complete the serial number so that there are no two units with the same number.

## Type designation key

The type designation contains information on the specifications and configuration of the drive module. The first digits from left express the basic configuration. The optional selections are given thereafter, separated by plus signs, eg, +E210. The main selections are described below. Not all selections are available for all types. For more information, refer to *ACS850-04 Ordering Information* (3AXD00000579470), available on request.

Code	Description
<b>Basic code, eg, ACS850-04-710A-5</b>	
<b>Product series</b>	
ACS850	ACS850 product series
<b>Type</b>	
04	Air-cooled drive module. When no options are selected: IP00 (UL type open), top entry and bottom exit for cables (terminals at the side of the module), external JCU Control Unit with a front cover but no control panel, no EMC filter, Standard Control Program, AC choke, coated boards, Safe torque off function, pedestal guide plate, extraction and insertion ramp, module fastening bracket and screws, <i>Hardware Manual</i> and multilingual <i>Quick Start-up Guide</i> and CD containing all manuals.
<b>Size</b>	
xxxA	Refer to the rating tables, page 115.
<b>Voltage range</b>	
5	380...500 V AC

Code	Description
<b>Option codes (plus codes)</b>	
<b>Resistor braking</b>	
D150	Brake chopper and brake resistor connection busbars, and R+ and R- terminals in the power cabling panel (+H381) if the panel is ordered
<b>Filters</b>	
E205	du/dt filter
E208	Common mode filter. Includes three extension busbars to the drive module output busbars with units without option +H381.
<b>Cabling panels</b>	
H381	Power cabling panels (U1, V1, W1, U2, V2, W2 terminals)
<b>DC busbars</b>	
H356	DC output busbars, and DC+ and DC- terminals in the power cabling panel (H381) if the panel is ordered
<b>Pedestal</b>	
0H354	No pedestal
<b>Control panel and control unit</b>	
J400	Control panel inserted onto the JCU Control Unit. Includes control panel mounting platform and internal cable.
J410	Control panel with door mounting kit. Includes control panel mounting platform, IP54 cover and a 3-meter panel connection cable.
J414	Control panel holder with cover and internal cable but no control panel. Not to be used with +J400.
0C168	Without front cover for the JCU Control Unit
P905	JCU Control Unit inside the circuit board compartment of drive module.
<b>Fieldbus adapter modules</b>	
K451	FDNA-01 DeviceNet™ adapter module
K452	FLON-01 LonWorks® adapter module
K454	FPBA-01 PROFIBUS DP adapter module
K457	FCAN-01 CANopen adapter module
K458	FSCA-01 Modbus adapter module
K466	FENA-01 Ethernet/IP™ and Modbus/TCP adapter module
K469	FECA-01 EtherCAT® adapter module
<b>I/O extension and feedback interface modules</b>	
L500	FIO-11 analog I/O extension module
L501	FIO-01 digital I/O extension module
L502	FEN-31 HTL incremental encoder interface module
L516	FEN-21 resolver interface module
L517	FEN-01 TTL incremental encoder interface module
L518	FEN-11 TTL absolute encoder interface module
L519	FIO-21 analog and digital I/O extension module
<b>Control programs</b>	
N2003	Standard control program version UIF12000
N2005	Standard control program version UIF12020
N3050	Crane technology library
N5050	Crane control program. Requires option +N3050.
<b>Warranty</b>	
P904	Extended warranty
<b>ATEX-certified function</b>	
Q971	ATEX-certified Safe motor disconnection function using the drive Safe torque off function

Code	Description
<b>Paper manuals. Note:</b> The delivered manual set may include manuals in English if the translation is not available.	
R700	English
R701	German
R702	Italian
R703	Dutch
R704	Danish
R705	Swedish
R706	Finnish
R707	French
R708	Spanish
R709	Portuguese
R711	Russian
R712	Chinese
R714	Turkish

# Planning the cabinet installation

---

## What this chapter contains

This chapter guides in planning drive cabinets and installing the drive module into a user-defined cabinet so that the front of the module faces the cabinet door. The chapter gives cabinet layout examples and free space requirements around the module for cooling. The issues discussed are essential for the safe and trouble-free use of the drive system.

**Note:** The installation must always be designed and made according to applicable local laws and regulations. ABB does not assume any liability whatsoever for any installation which breaches the local laws and/or other regulations.

## Basic requirements for the cabinet

Use a cabinet which:

- has a frame sturdy enough to carry the weight of the drive components, control circuitry and other equipment installed in it
- protects the user and drive module against contact and meets the requirements for dust and humidity
- has sufficient air inlet and outlet vents that allow free flow of the drive cooling air through the cabinet.

## Planning the layout of the cabinet

Design a spacious layout to ensure easy installation and maintenance. Sufficient cooling air flow, obligatory clearances, cables and cable support structures all require space.

Place the control board(s) away from:

- main circuit components such as contactor, switches and power cables
- hot parts (heat sink, air outlet of the drive module).

### Layout examples, door closed

Layout examples for IP22 and IP54 cabinets are shown below (input power cable lead-through from top and motor cable lead-through from bottom).

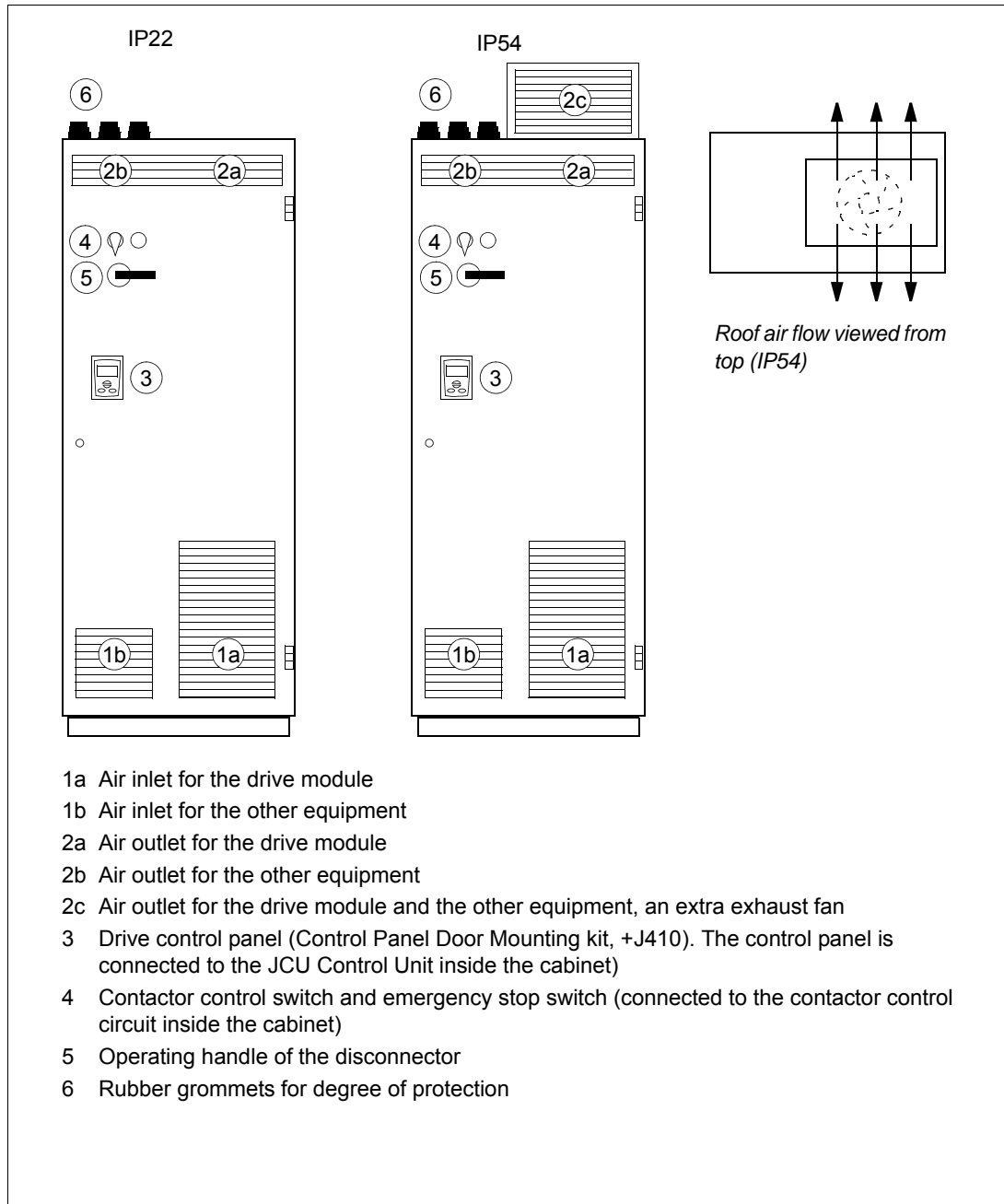

### Layout examples, door open

Layout examples for units in IP22 and IP54 cabinets are shown below. Optional cabling panels (+H318) are not used. .

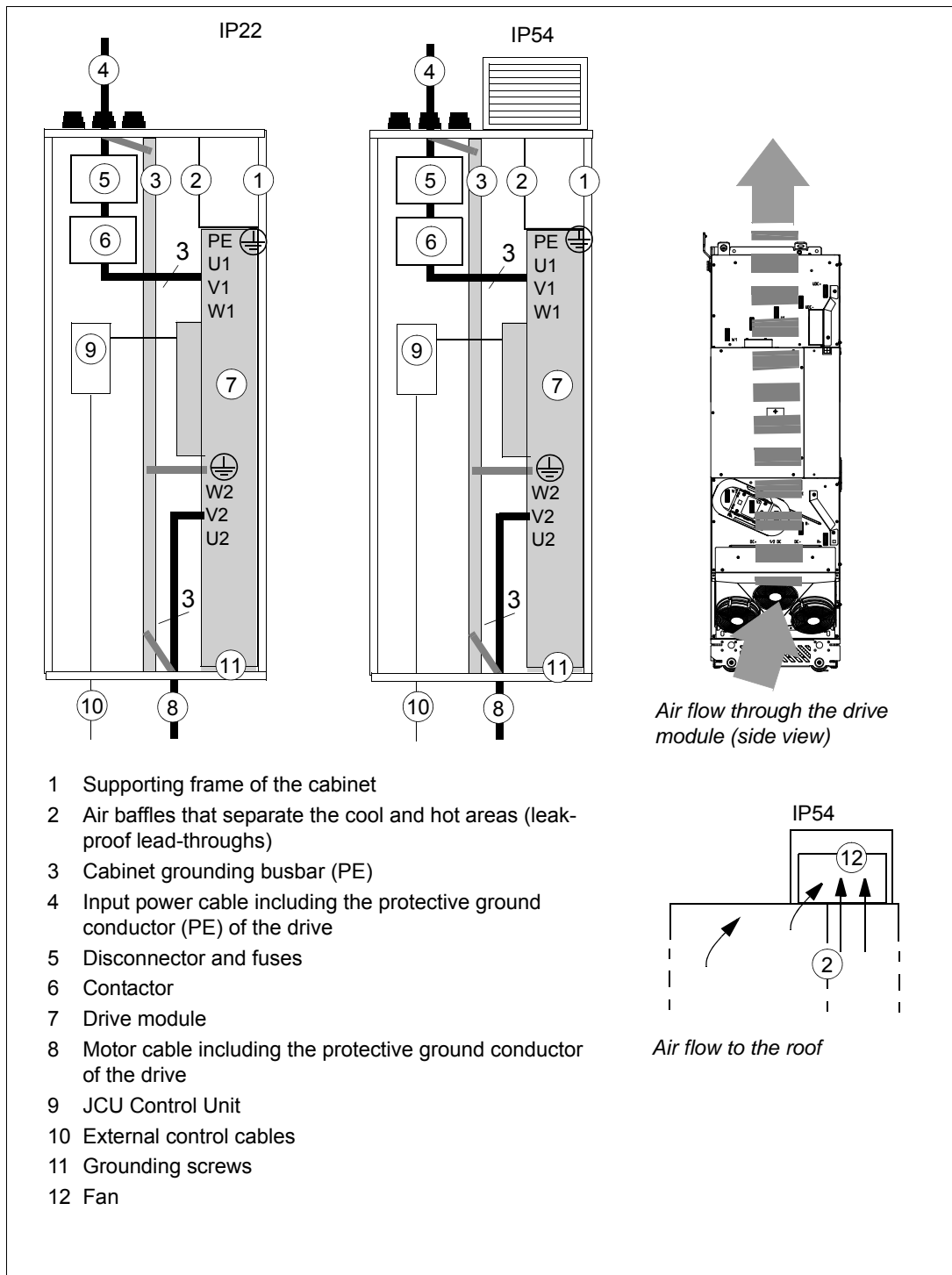

**Note 1:** The power cable shields can also be grounded to the drive module grounding terminals.

**Note 2:** See also section [Required free space](#), page 43.

## Arranging the grounding inside the cabinet

Arrange the grounding of the drive module by leaving the contact surfaces of the fastening points unpainted (bare metal-to-metal contact). The module frame will be grounded to the PE busbar of the cabinet via the fastening surfaces, screws and the cabinet frame. Alternatively, use a separate grounding conductor between the PE terminal of the drive module and the PE busbar of the cabinet.

Ground also the other components in the cabinet according to the principle above.

## Selecting the busbar material and preparation of the joints

If planning the use of busbars, note the following:

- Tin-plated copper is recommended but aluminium can also be used.
- The oxide layer from aluminium busbar joints must be removed and suitable anti-oxidant joint compound applied.

## Tightening torques

Apply the following torques to grade 8.8 screws (with or without joint compound) that tighten electric contacts.

Screw size	Torque
M5	3.5 N·m (2.6 lbf·ft)
M6	9 N·m (6.6 lbf·ft)
M8	20 N·m (14.8 lbf·ft)
M10	40 N·m (29.5 lbf·ft)
M12	70 N·m (52 lbf·ft)
M16	180 N·m (133 lbf·ft)

## Planning the fastening of the cabinet

Note the following when planning the fastening of the cabinet:

- Fasten the cabinet to the floor from the front and to the floor or wall from the back.
- Always fasten the drive module from its fastening points to the cabinet . For details, see the module installation instructions.



**WARNING!** Do not fasten the cabinet by electric welding. ABB does not assume any liability for damages caused by electric welding as the welding circuit may damage electronic circuits in the cabinet.

## Planning the cabinet placement on a cable channel

Note the following when planning to place the cabinet on a cable channel:

- The cabinet structure must be sturdy enough. If the whole cabinet base will not be supported from below, the cabinet weight will lie on the sections that the floor carries.
- Equip the cabinet with a sealed bottom plate and cable lead-throughs to ensure the degree of protection and to prevent the cooling air flow from the cable channel into the cabinet.

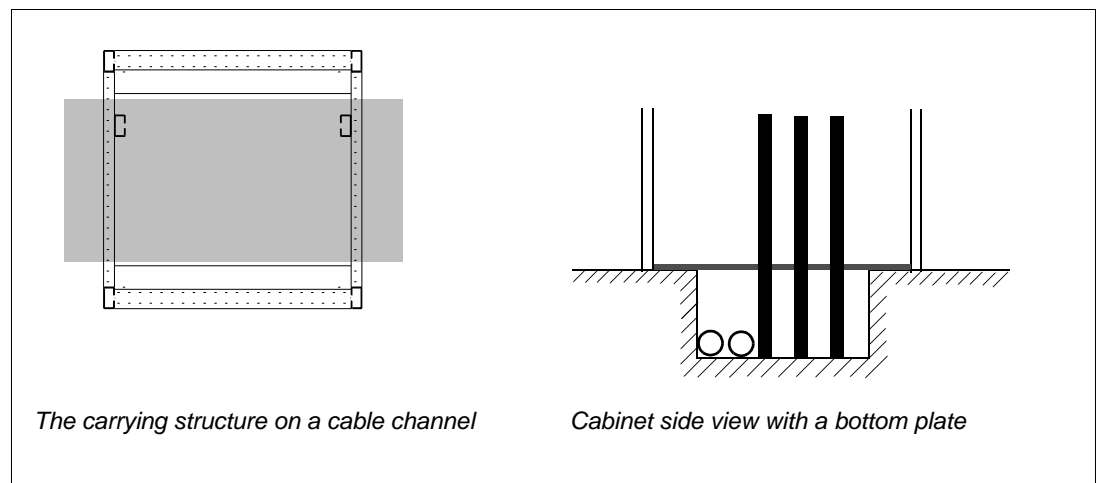

## Planning the electromagnetic compatibility (EMC) of the cabinet

Note following when planning the electromagnetic compatibility of the cabinet:

- Generally, the fewer and smaller the holes in the cabinet, the better the interference attenuation. The maximum recommended diameter of a hole in galvanic metal contact in the covering cabinet structure is 100 mm. Pay special attention to the cooling air inlet and outlet gratings.
- The best galvanic connection between the steel panels is achieved by welding them together as no holes are necessary. If welding is not possible, the seams between the panels **are recommended to be left unpainted** and equipped with special conductive EMC strips to provide adequate galvanic connection. Usually, reliable strips are made of flexible silicon mass covered with a metal mesh. The non-tightened touch-contact of the metal surfaces is not sufficient, so a conductive gasket between the surfaces is required. The maximum recommended distance between assembly screws is 100 mm.
- Construct sufficient high-frequency grounding network in the cabinet to avoid voltage differences and forming of high-impedance radiator structures. A good high-frequency grounding is made with short flat copper braids for low inductance. One-point high-frequency grounding cannot be used due to the long distances inside the cabinet.

- 360° high frequency grounding of the cable shields at the cable lead-throughs improves the EMC shielding of the cabinet.
- 360° high frequency grounding of the motor cable shields at their entries is recommended. The grounding can be implemented by a knitted wire mesh screening as shown below.

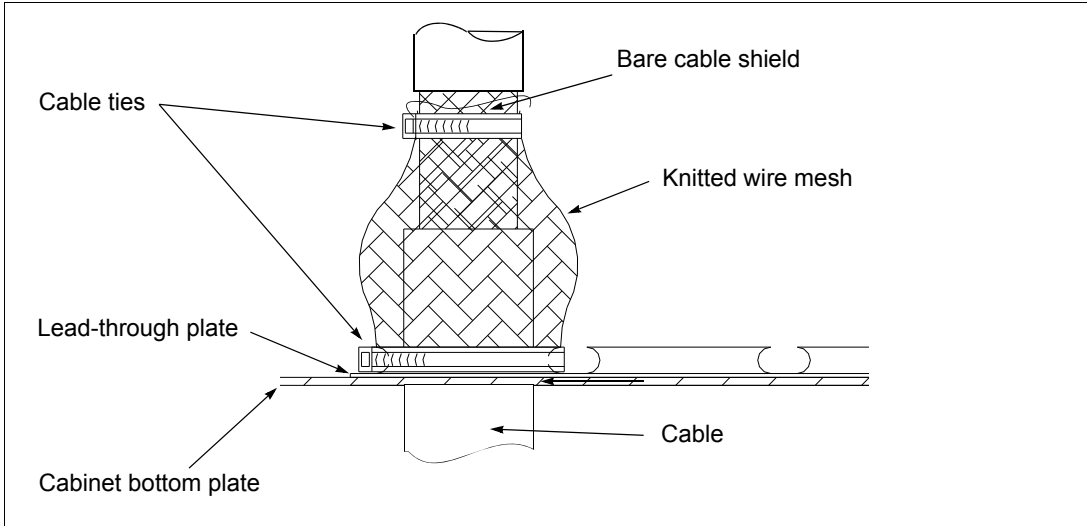

- 360° high frequency grounding of the control cable shields is recommended at their entries. The shields can be grounded by means of conductive shielding cushions pressed against the cable shield from both directions:

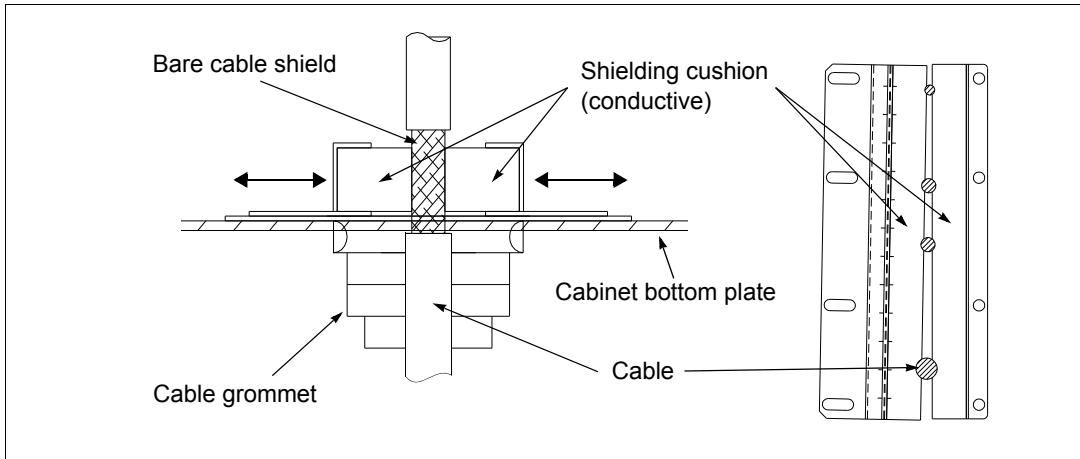

## Planning the grounding of the cable shields at the cabinet lead-through

Follow the principle shown below when planning the grounding of the cable shields at the cabinet lead-through.

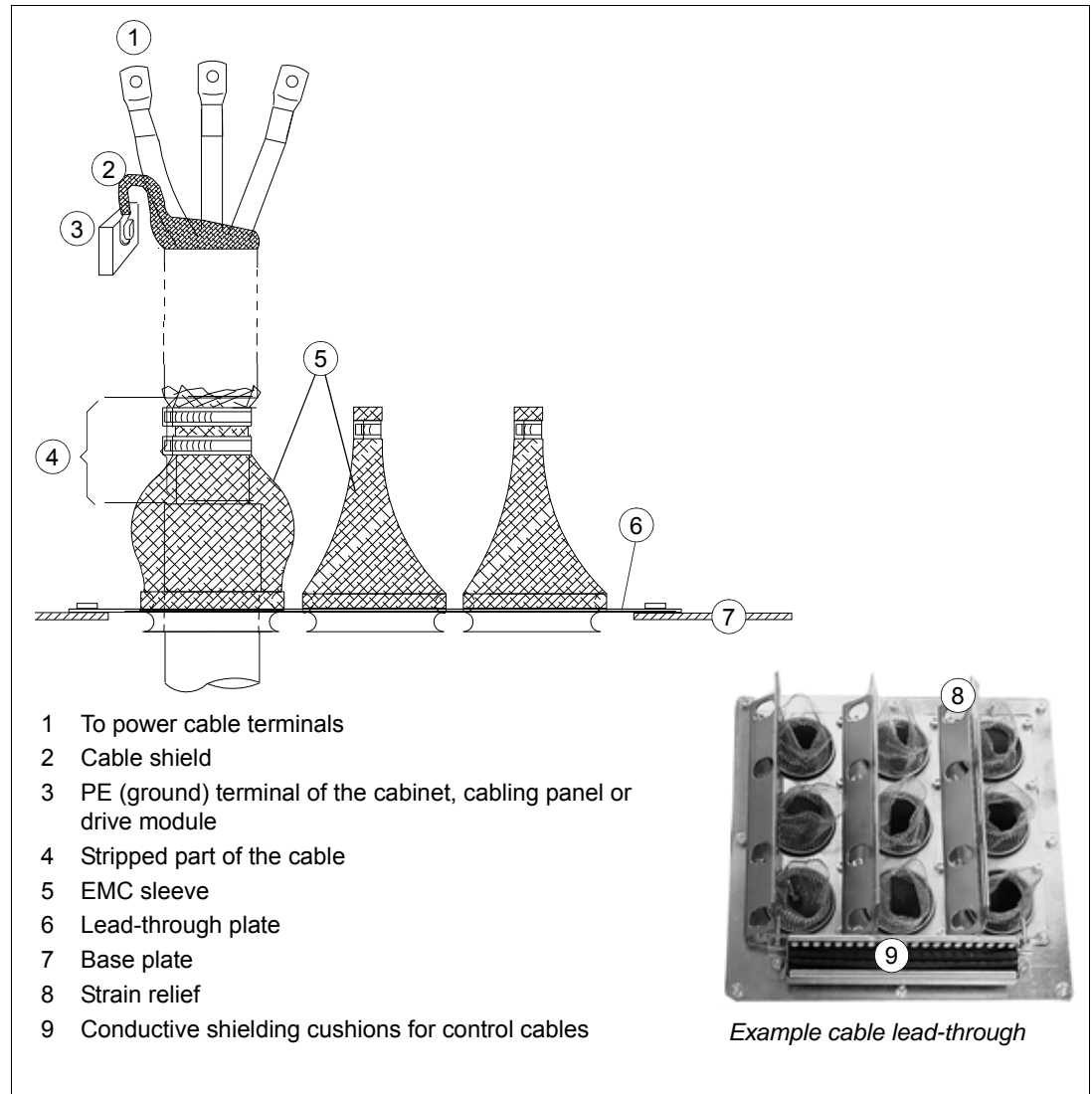

## Planning the cooling

Note following guidelines when planning the cooling of the cabinet:

- Ventilate the installation site sufficiently so that the cooling air flow and ambient temperature requirements of the drive module are met, see pages 117 and 122. The internal cooling fan of the drive module rotates at a constant speed thus blowing constant air flow through the module. Whether the same amount of air must be replaced all the time in the facility depends on how much heat must be removed.

- Leave enough free space around the components to ensure sufficient cooling. Observe the minimum clearances given for each component. For the required free space around the drive module, see page 43.
- Also ventilate the heat dissipated by cables and other additional equipment.
- Equip the air inlets and outlets with gratings that:
  - guide the air flow
  - protect against contact
  - prevent water splashes from entering the cabinet.
- The drawing below shows two typical cabinet cooling solutions. The air inlet is at the bottom of the cabinet, while the outlet is at the top, either on the upper part of the door or on the roof.

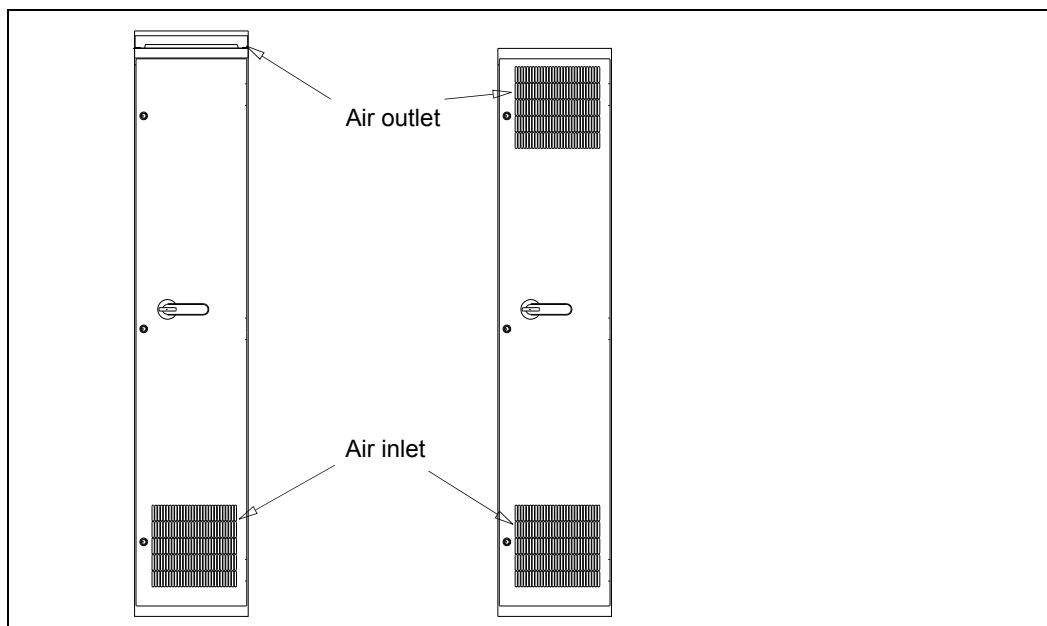

- The internal cooling fans of the drive modules and reactors/chokes are usually sufficient to keep the component temperatures low enough in IP22 cabinets.
- In IP54 cabinets, thick filter mats are used to prevent water splashes from entering the cabinet. This entails the installation of additional cooling equipment, such as a hot air exhaust fan.
- See page 117 for:
  - allowed temperature rise inside the cabinet
  - allowed pressure drop over the cabinet that the module fan can overcome
  - air inlet and outlet sizes required for the module cooling and recommended filter material (if used).

## Preventing the recirculation of hot air

Prevent hot air circulation outside the cabinet by leading the outgoing hot air away from the area where the inlet air to the cabinet is taken. Possible solutions are listed below:

- gratings that guide air flow at the air inlet and outlet
- air inlet and outlet at different sides of the cabinet
- cool air inlet in the lower part of the front door, and an extra exhaust fan on the roof of the cabinet.

Prevent hot air circulation inside the cabinet with, for example, leak-proof air baffles at the positions shown below. No gaskets are usually required.

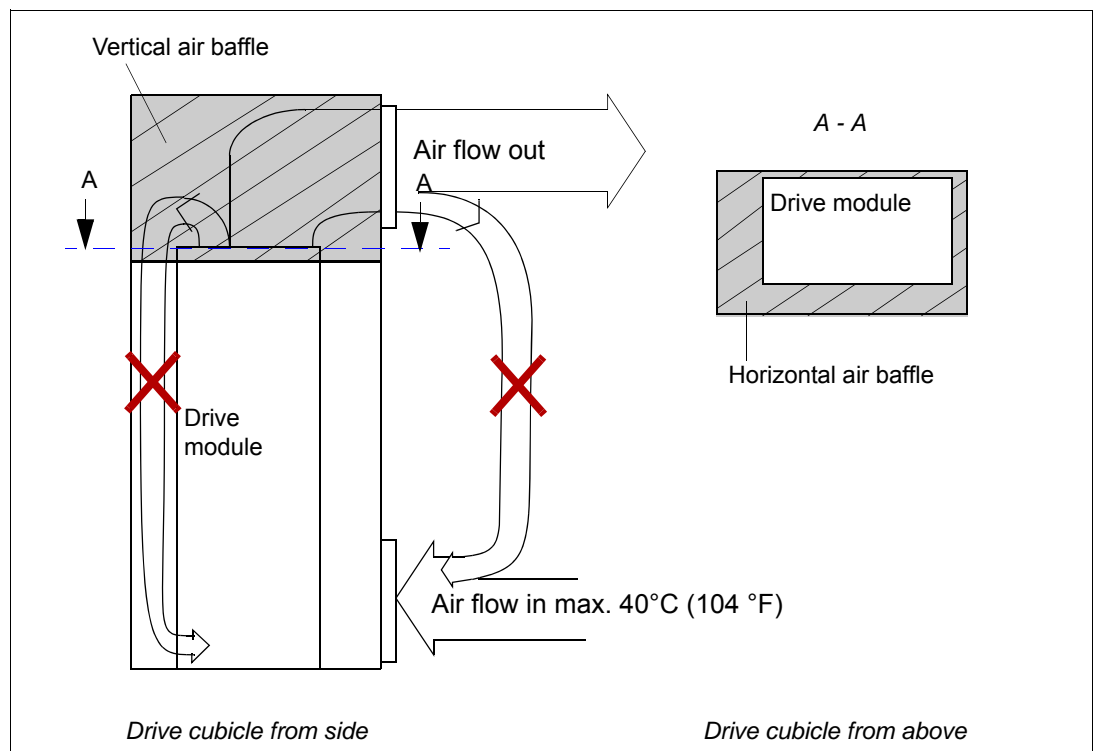

## Required free space

Free space around the drive module is needed for ensuring that sufficient cooling air flows through the module and that the module cools properly.

### Free space at top with air inlet gratings in the cabinet door

The required free space at the top of the module is shown below when the air inlet gratings are located only in the lower part of the cabinet door.

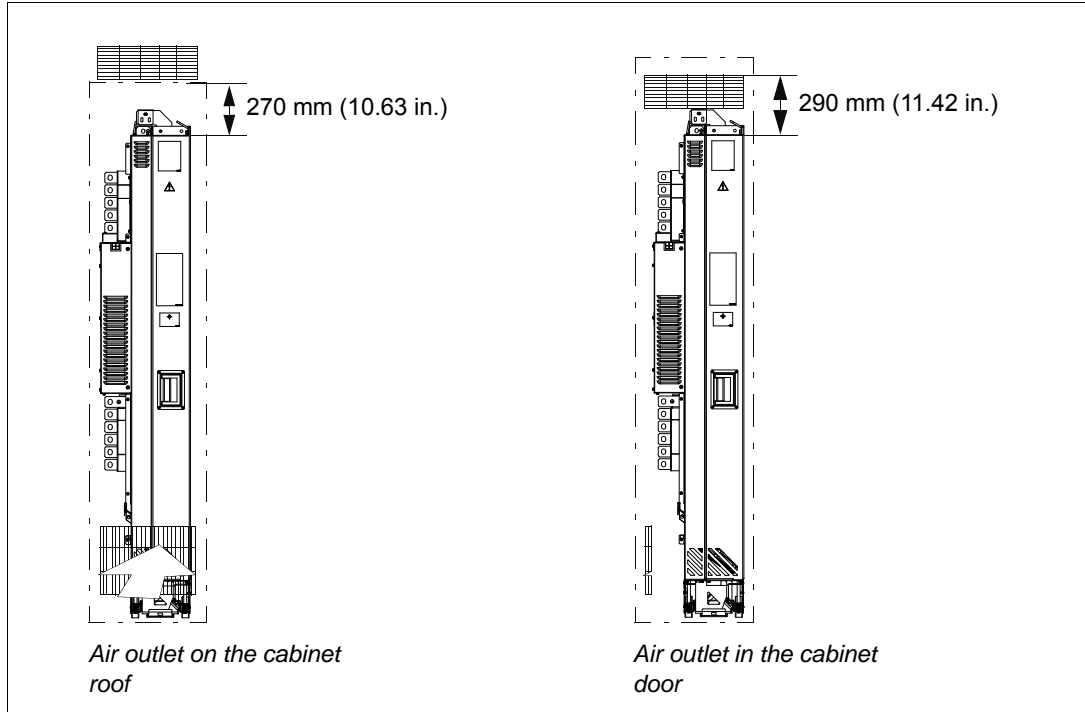

### Free space around the drive module

45 mm (1.77 in.) free space around the drive module is required from the cabinet right-hand side, back panel and front door. 20 mm (0.79 in.) free space is required at the left-hand side of the module.

### Other installation positions

Contact your local ABB representative.

### Planning the placement of the control panel

Note the following alternatives when planning the placement of the control panel:

- The control panel can be snapped on the control unit of the drive. See page 28.
- The control panel can be mounted onto the cabinet door using the control panel mounting kit (+J410). For the installation instructions, refer to *ACS-CP-U Control Panel IP54 Mounting Platform Kit (+J410) Installation Guide (3AUA0000049072 [English])*.

## **Planning the use of the cubicle heaters**

Use a cubicle heater if there is a risk of condensation in the cabinet. Although the primary function of the heater is to keep the air dry, it may also be required for heating at low temperatures.



# Planning the electrical installation

---

## What this chapter contains

This chapter contains the instructions that you must follow when selecting the motor, cables, protections, cable routing and way of operation for the drive system.

**Note:** The installation must always be designed and made according to applicable local laws and regulations. ABB does not assume any liability whatsoever for any installation which breaches the local laws and/or other regulations. Furthermore, if the recommendations given by ABB are not followed, the drive may experience problems that the warranty does not cover.

## Selecting the supply disconnecting device (disconnecting means)

Install a hand-operated input disconnecting device (disconnecting means) between the AC power source and the drive. The disconnecting device must be of a type that can be locked to the open position for installation and maintenance work. The disconnecting device must be located in the cabinet in which the drive module is installed.

### European Union

To meet the European Union Directives, according to standard EN 60204-1, *Safety of Machinery*, the disconnecting device must be one of the following types:

- switch-disconnector of utilization category AC-23B (EN 60947-3)
- disconnector that has an auxiliary contact that in all cases causes switching devices to break the load circuit before the opening of the main contacts of the disconnector (EN 60947-3)
- circuit breaker suitable for isolation in accordance with EN 60947-2.

### Other regions

The disconnecting device must conform to the applicable safety regulations.

## Selecting and dimensioning the main contactor

If a main contactor is used, its utilization category (number of operations under load) must be AC-1 according to IEC 60947-4, *Low-voltage switchgear and controlgear*. Dimension the main contactor according to the nominal voltage and current of the drive.

## Protecting the motor insulation and bearings

The drive employs modern IGBT inverter technology. Regardless of frequency, the drive output comprises pulses of approximately the drive DC bus voltage with a very short rise time. The pulse voltage can almost double at the motor terminals, depending on the attenuation and reflection properties of the motor cable and the terminals. This can cause additional stress on the motor and motor cable insulation.

Modern variable speed drives with their fast rising voltage pulses and high switching frequencies can generate current pulses that flow through the motor bearings, which can gradually erode the bearing races and rolling elements.

Optional  $du/dt$  filters protect motor insulation system and reduce bearing currents. Common mode filters mainly reduce bearing currents. Insulated N-end (non-drive) bearings protect the motor bearings. See section [Checking the compatibility of the motor and drive](#) below for the required filters and N-end bearings to be used with the drive. Select and install the cables according to the instructions given in the hardware manual.

## Checking the compatibility of the motor and drive

Use an AC induction motor or a permanent magnet synchronous motor with the drive. Several induction motors can be connected at a time but only one permanent magnet motor.

Select the motor and drive according to the rating tables in chapter *Technical Data*. Use the DriveSize PC tool if the default load cycles are not applicable.

1. Check that the motor ratings lie within the allowed ranges of the drive control program:
  - motor nominal voltage is in the range of  $1/2 \dots 2 \cdot U_N$
  - motor nominal current is  $1/6 \dots 2 \cdot I_{Hd}$  of the drive in DTC control and  $0 \dots 2 \cdot I_{Hd}$  in scalar control. The control mode is selected by a control program parameter.
2. Check that the motor voltage rating meets the application requirements:

When	... the motor voltage rating should be ...
No resistor braking is in use	$U_N$
Frequent or long term brake cycles will be used	$1.21 \cdot U_N$

$U_N \hat{=}$  Input voltage of the drive

See section [Resistor braking of the drive](#) on page 51.

3. Consult the motor manufacturer before using a motor in a drive system where the motor nominal voltage differs from the AC power source voltage.
4. Ensure that the motor insulation system withstands the maximum peak voltage in the motor terminals. See the [Requirements table](#) below for the required motor insulation system and drive filtering.

**Example 1:** When the supply voltage is 440 V and the drive is operating in the motor mode only, the maximum peak voltage in the motor terminals can be approximated as follows:  $440 \text{ V} \cdot 1.35 \cdot 2 = 1190 \text{ V}$ . Check that the motor insulation system withstands this voltage.

### Requirements table

The following table shows how to select the motor insulation system and when optional ABB  $du/dt$  filters, insulated N-end (non-drive end) motor bearings and ABB common mode filters are required. Failure of the motor to fulfil the following requirements or improper installation may shorten motor life or damage the motor bearings and voids the warranty.

Manufacturer	Motor type	Nominal AC line voltage	Requirement for		
			Motor insulation system	ABB $du/dt$ filter, insulated N-end bearing and ABB common mode filter	
				$P_N < 350 \text{ kW}$ or frame size $\geq \text{IEC 315}$	$P_N \geq 350 \text{ kW}$ or frame size $\geq \text{IEC 400}$
			$P_N < 469 \text{ hp}$ or frame size $\geq \text{NEMA 500}$	$P_N \geq 469 \text{ hp}$ or frame size $> \text{NEMA 580}$	
A B B	Random-wound M2_ and M3_	$U_N \leq 500 \text{ V}$	Standard	+ N	+ N + CMF
		$500 \text{ V} < U_N \leq 600 \text{ V}$	Standard	+ $du/dt$ + N	+ $du/dt$ + N + CMF
			or		
			Reinforced	+ N	+ N + CMF
		$600 \text{ V} < U_N \leq 690 \text{ V}$ (cable length $\leq 150 \text{ m}$ )	Reinforced	+ $du/dt$ + N	+ $du/dt$ + N + CMF
	$600 \text{ V} < U_N \leq 690 \text{ V}$ (cable length $> 150 \text{ m}$ )	Reinforced	+ N	+ N + CMF	
Form-wound HX_ and AM_	$380 \text{ V} < U_N \leq 690 \text{ V}$	Standard	+ N + CMF	$P_N < 500 \text{ kW}$ : + N + CMF	
				$P_N \geq 500 \text{ kW}$ : + N + CMF + $du/dt$	
Old* form-wound HX_ and modular	$380 \text{ V} < U_N \leq 690 \text{ V}$	Check with the motor manufacturer.	+ $du/dt$ with voltages over 500 V + N + CMF		
Random-wound HX_ and AM_**	$0 \text{ V} < U_N \leq 500 \text{ V}$	Enamelled wire with fiber glass taping	+ N + CMF		
	$500 \text{ V} < U_N \leq 690 \text{ V}$		+ $du/dt$ + N + CMF		

Manufacturer	Motor type	Nominal AC line voltage	Requirement for			
			Motor insulation system	ABB du/dt filter, insulated N-end bearing and ABB common mode filter		
				$P_N < 350 \text{ kW}$ or frame size $\geq \text{IEC 315}$	$P_N \geq 350 \text{ kW}$ or frame size $\geq \text{IEC 400}$	
			$P_N < 469 \text{ hp}$ or frame size $\geq \text{NEMA 500}$	$P_N \geq 469 \text{ hp}$ or frame size $> \text{NEMA 580}$		
NON-ABB	Random-wound and form-wound	$U_N \leq 420 \text{ V}$	Standard: $\hat{U}_{LL} = 1300 \text{ V}$	+ N or CMF	+ N + CMF	
		$420 \text{ V} < U_N \leq 500 \text{ V}$	Standard: $\hat{U}_{LL} = 1300 \text{ V}$	+ du/dt + N	+ du/dt + N + CMF	
				or		
				+ du/dt + CMF		
		or				
		$500 \text{ V} < U_N \leq 600 \text{ V}$	Reinforced: $\hat{U}_{LL} = 1600 \text{ V}$ , 0.2 microsecond rise time	+ N or CMF	+ N + CMF	
				+ du/dt + N		+ du/dt + N + CMF
				or		
				+ du/dt + CMF		
		or				
$600 \text{ V} < U_N \leq 690 \text{ V}$	Reinforced: $\hat{U}_{LL} = 1800 \text{ V}$	+ N or CMF	+ N + CMF			
		+ du/dt + N		+ du/dt + N + CMF		
		Reinforced: $\hat{U}_{LL} = 2000 \text{ V}$ , 0.3 microsecond rise time ***			N + CMF	N + CMF

\* manufactured before 1.1.1998

\*\* For motors manufactured before 1.1.1998, check for additional instructions with the motor manufacturer.

\*\*\* If the intermediate DC circuit voltage of the drive is increased from the nominal level by resistor braking, check with the motor manufacturer if additional output filters are needed in the applied drive operation range.

The abbreviations used in the table are defined below.

Abbreviation	Definition
$U_N$	Nominal voltage of the supply network
$\hat{U}_{LL}$	Peak line-to-line voltage at motor terminals which the motor insulation must withstand
$P_N$	Motor nominal power
du/dt	du/dt filter at the output of the drive +E205
CMF	Common mode filter +E208
N	N-end bearing: insulated motor non-drive end bearing
n.a.	Motors of this power range are not available as standard units. Consult the motor manufacturer.

### Explosion-safe (EX) motors

Consult the motor manufacturer regarding the construction of the motor insulation and additional requirements for explosion-safe (EX) motors.

### High-output motors and IP 23 motors

For motors with higher rated output than what is stated for the particular frame size in EN 50347 (2001) and for IP23 motors, the requirements of ABB random-wound motor series (for example M3AA, M3AP, M3BP) are given below. For non-ABB motor types, see the [Requirements table](#) above. Apply the requirements of range  $P_N \geq 350 \text{ kW}$  to motors within the range  $P_N < 350 \text{ kW}$ . In other cases, consult the motor manufacturer.

Manufacturer	Motor type	Nominal mains voltage (AC line voltage)	Requirement for		
			Motor insulation system	ABB du/dt filter, insulated N-end bearing and ABB common mode filter	
				$P_N < 200 \text{ kW}$	$P_N \geq 200 \text{ kW}$
				$P_N < 268 \text{ hp}$	$P_N \geq 268 \text{ hp}$
A B B	Random-wound	$U_N \leq 500 \text{ V}$	Standard	+ N	+ N + CMF
		$500 \text{ V} < U_N \leq 600 \text{ V}$	Standard	+ du/dt + N	+ du/dt + N + CMF
			or		
		Reinforced	+ N	+ N + CMF	
$600 \text{ V} < U_N \leq 690 \text{ V}$	Reinforced	+ du/dt + N	+ du/dt + N + CMF		

### HXR and AMA motors

All AMA machines (manufactured in Helsinki) for drive systems have form-wound windings. All HXR machines manufactured in Helsinki starting 1.1.1998 have form-wound windings.

### ABB motors of types other than M2\_, M3\_, HX\_ and AM\_

Use the selection criteria given for non-ABB motors.

### Resistor braking of the drive

When the drive is in the braking mode for a large part of its operation time, the intermediate circuit DC voltage of the drive increases, the effect being similar to increasing the supply voltage by up to 20 percent. Take voltage increase into consideration when determining the motor insulation requirement.

Example: Motor insulation requirement for a 400 V application must be selected as if the drive were supplied with 480 V.

### Calculating the rise time and the peak line-to-line voltage

The peak line-to-line voltage at the motor terminals generated by the drive as well as the voltage rise time depend on the cable length. The requirements for the motor insulation system given in the table are "worst case" requirements covering installations with 30 meter and longer cables. The rise time can be calculated as follows:  $\Delta t = 0.8 \cdot \hat{U}_{LL} / (du/dt)$ . Read  $\hat{U}_{LL}$  and  $du/dt$  from the diagrams below. Multiply the values of the graph by the supply voltage ( $U_N$ ). In case of drives with resistor braking, the  $\hat{U}_{LL}$  and  $du/dt$  values are approximately 20% higher.

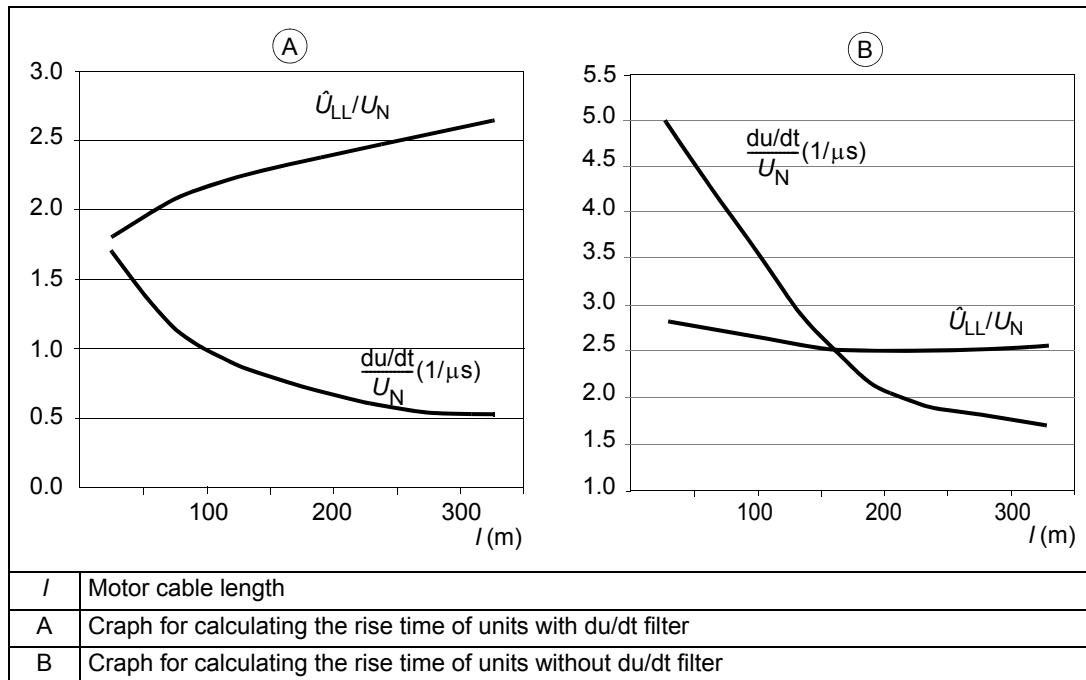

### Sine filters

Sine filters protect the motor insulation system. Therefore,  $du/dt$  filter can be replaced with a sine filter. The peak phase-to-phase voltage with the sine filter is approximately  $1.5 \cdot U_N$ .

### Common mode filters

Common mode filter is available as a plus code option (+E208).

## Selecting the power cables

### General rules

Dimension the input power and motor cables **according to local regulations**:

- Dimension the cable to carry the drive load current. See chapter *Technical data* for the rated currents.
- Select a cable rated for at least 70 °C maximum permissible temperature of conductor in continuous use. For US, see [Additional US requirements](#), page 55.
- The inductance and impedance of the PE conductor/cable (grounding wire) must be rated according to permissible touch voltage appearing under fault conditions (so that the fault point voltage will not rise excessively when a ground fault occurs).
- 600 V AC cable is accepted for up to 500 V AC.

Use symmetrical shielded motor cable, see page 55.

**Note:** When continuous metal conduit is employed, shielded cable is not required. The conduit must have bonding at both ends as with cable shield.

A four-conductor system is allowed for input cabling, but shielded symmetrical cable is recommended. To operate as a protective conductor, the shield conductivity requirements according to IEC 60439-1 are shown below when the protective conductor is made of the same metal as the phase conductors:

Cross-sectional area of the phase conductors $S$ (mm <sup>2</sup> )	Minimum cross-sectional area of the corresponding protective conductor $S_p$ (mm <sup>2</sup> )
$S \leq 16$	$S$
$16 < S \leq 35$	16
$35 < S$	$S/2$

Compared to a four-conductor system, the use of symmetrical shielded cable reduces electromagnetic emission of the whole drive system as well as the stress on motor insulation, bearing currents and wear.

Keep the motor cable and its PE pigtail (twisted shield) as short as possible to reduce high-frequency electromagnetic emissions.

### Typical power cable sizes

The table below gives copper and aluminium cable types for different load currents. Cable sizing is based on max. 9 cables laid on a cable ladder side by side, three ladder type trays one on top of the other, ambient temperature 30 °C, PVC insulation, surface temperature 70 °C (EN 60204-1 and IEC 60364-5-52). For other conditions, dimension the cables according to local safety regulations, appropriate input voltage and the load current of the drive. See also [Terminal and lead-through data for the power cables](#) on page 117.

Copper cables with concentric copper shield		Aluminium cables with concentric copper shield	
Max. load current A	Cable type mm <sup>2</sup>	Max. load current A	Cable type mm <sup>2</sup>
669	3 × (3×150)	693	3 × (3×240)
765	3 × (3×185)	800	3 × (3×300)
903	3 × (3×240)	924	4 × (3×240)

3BFA 01051905 D

### Typical power cable sizes (US)

Cable sizing is based on NEC Table 310-16 for copper wires, 75 °C (167 °F) wire insulation at 40 °C (104 °F) ambient temperature. Not more than three current-carrying conductors in raceway or cable or earth (directly buried). For other conditions, dimension the cables according to local safety regulations, appropriate input voltage and the load current of the drive. See also *Terminal and lead-through data for the power cables* on page 117.

Copper cables with concentric copper shield		Aluminium cables with concentric copper shield	
Max. load current A	Cable type AWG/kcmil	Max. load current A	Cable type AWG/kcmil
739	2 × 600 MCM or 3 × 300 MCM	660	2 × 700 MCM or 3 × 350 MCM
810	2 × 700 MCM or 3 × 350 MCM	884	3 × 400 MCM or 4 × 250 MCM
884	3 × 400 MCM or 4 × 250 MCM	898	3 × 600 MCM or 4 × 400 MCM

### Alternative power cable types

The power cable types that can be used with the drive are represented below.

**Recommended:** Symmetrical shielded cable: three phase conductors and a concentric or otherwise symmetrically constructed PE conductor, and a shield

**Note:** A separate PE conductor is required if the conductivity of the cable shield is < 50 % of the conductivity of the phase conductor.

**Not allowed for motor cabling:** A four-conductor system (three phase conductors and a protective conductor)

**Not allowed for input or motor cabling:** Symmetrical cable with individual shields for each phase conductor

### Motor cable shield

To effectively suppress radiated and conducted radio-frequency emissions, the shield conductivity must be at least 1/10 of the phase conductor conductivity. The requirements are easily met with a copper or aluminium shield. The minimum requirement of the motor cable shield of the drive is shown below. It consists of a concentric layer of copper wires with an open helix of copper tape or copper wire. The better and tighter the shield, the lower the emission level and bearing currents.

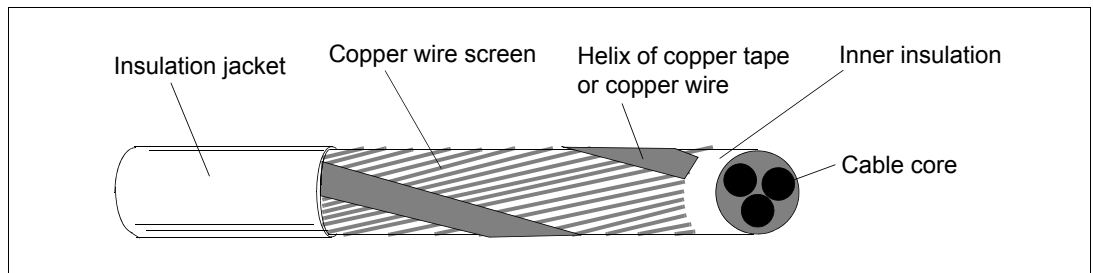

### Additional US requirements

Use type MC continuous corrugated aluminum armor cable with symmetrical grounds or shielded power cable for the motor cables if metallic conduit is not used. For the North American market, 600 V AC cable is accepted for up to 500 V AC. For drives rated over 100 amperes, the power cables must be rated for 75 °C (167 °F).

#### Conduit

Couple separate parts of a conduit together: bridge the joints with a ground conductor bonded to the conduit on each side of the joint. Bond the conduits also to the drive enclosure and motor frame. Use separate conduits for input power, motor, brake resistor, and control wiring. When conduit is employed, type MC continuous corrugated aluminium armor cable or shielded cable is not required. A dedicated ground cable is always required.

**Note:** Do not run motor wiring from more than one drive in the same conduit.

#### Armored cable / shielded power cable

Six conductor (3 phases and 3 ground) type MC continuous corrugated aluminum armor cable with symmetrical grounds is available from the following suppliers (trade names in parentheses):

- Anixter Wire & Cable (Philsheath)
- BICC General Corp (Philsheath)
- Rockbestos Co. (Gardex)
- Oaknite (CLX).

Shielded power cables are available from Belden, LAPPKABEL (ÖLFLEX) and Pirelli.

## Selecting the control cables

### Shielding

All control cables must be shielded.

Use a double-shielded twisted pair cable for analog signals. This type of cable is recommended for the pulse encoder signals also. Employ one individually shielded pair for each signal. Do not use common return for different analog signals.

A double-shielded cable is the best alternative for low-voltage digital signals but single-shielded twisted pair cable is also usable.

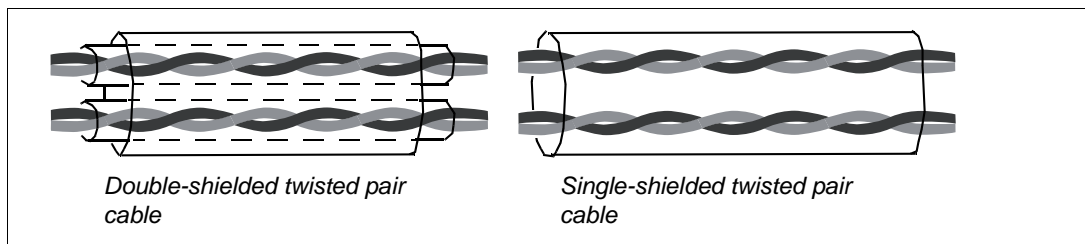

### Signals in separate cables

Run analog and digital signals in separate, shielded cables.

Never mix 24 V DC and 115/230 V AC signals in the same cable.

### Signals allowed to be run in the same cable

Relay-controlled signals, providing their voltage does not exceed 48 V, can be run in the same cables as digital input signals. It is recommended that the relay-controlled signals be run as twisted pairs.

### Relay cable type

The cable type with braided metallic screen (for example ÖLFLEX by LAPPKABEL, Germany) has been tested and approved by ABB.

### Control panel cable length and type

In remote use, the cable connecting the control panel to the drive must not exceed 3 meters (10 ft). The cable type tested and approved by ABB is used in control panel option kits.

## Routing the cables

Route the motor cable away from other cable routes. Motor cables of several drives can be run in parallel installed next to each other. It is recommended that the motor cable, input power cable and control cables be installed on separate trays. Avoid long parallel runs of motor cables with other cables in order to decrease electromagnetic interference caused by the rapid changes in the drive output voltage.

Where control cables must cross power cables ensure that they are arranged at an angle as near to 90 degrees as possible. Do not run extra cables through the drive.

The cable trays must have good electrical bonding to each other and to the grounding electrodes. Aluminium tray systems can be used to improve local equalizing of potential.

A diagram of the cable routing is shown below.

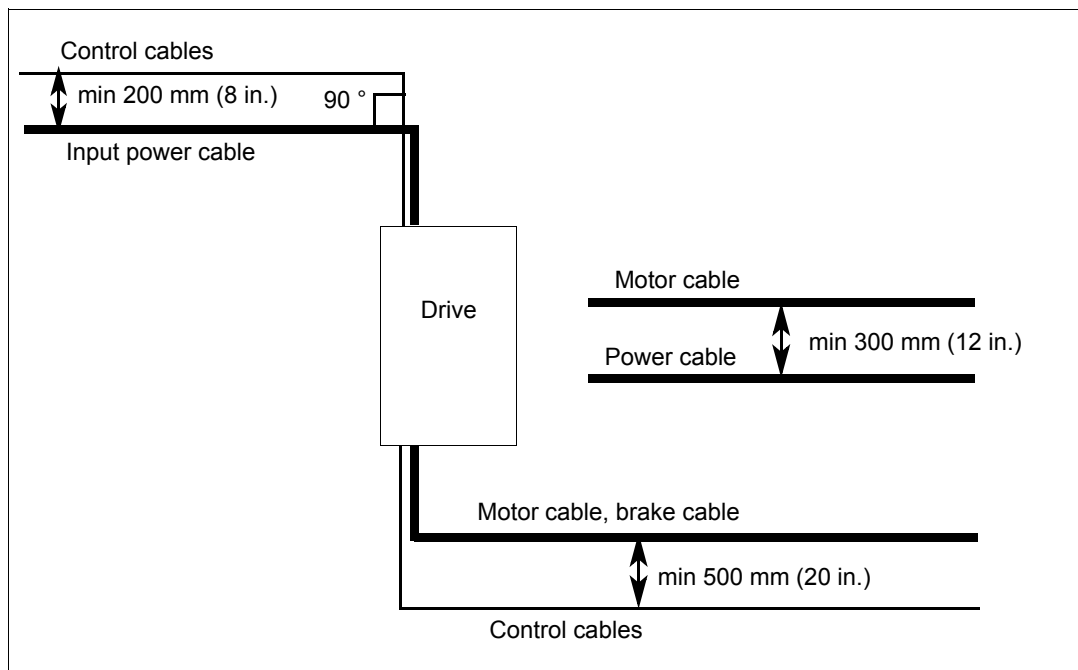

### Separate control cable ducts

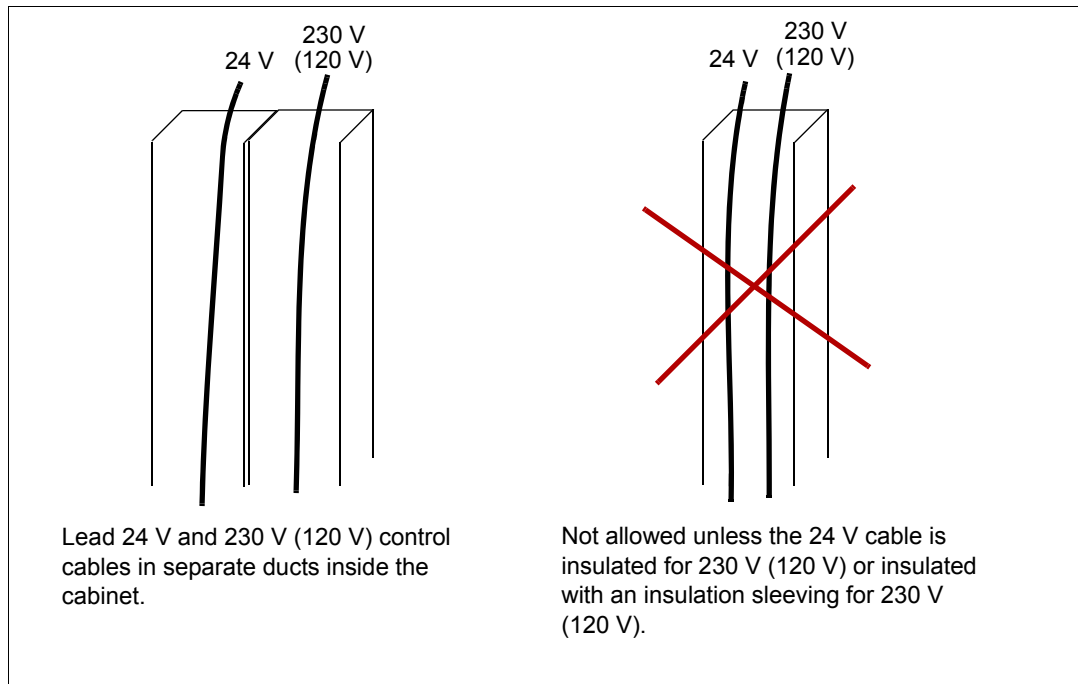

### Continuous motor cable shield or enclosure for equipment in the motor cable

To ensure safety and minimize the emission level when safety switches, contactors, connection boxes or similar equipment are installed in the motor cable between the drive and the motor:

- European Union: Install the equipment in a metal enclosure with 360 degree grounding for the shields of both the incoming and outgoing cable, or connect the shields of the cables otherwise together.
- US: Install the equipment in a metal enclosure in a way that the conduit or motor cable shielding runs consistently without breaks from the drive to the motor.

## Implementing thermal overload and short-circuit protection

### Protecting the drive and input power cable in short-circuits

Protect the drive with fuses and the input cable with fuses or a circuit breaker as shown below:

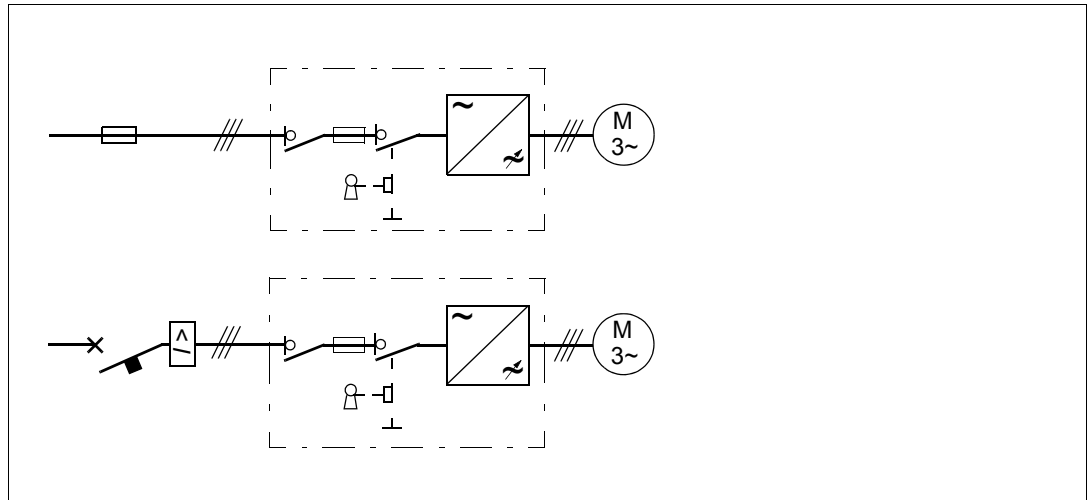

Size the fuses or circuit breaker at the distribution board according to local regulations for the input cable protection. Select the fuses for the drive according to the instructions given in chapter [Technical data](#). The fuses for the drive protection will restrict drive damage and prevent damage to adjoining equipment in case of a short-circuit inside the drive.

**Note 1:** If the fuses for the drive protection are placed at the distribution board and the input cable is dimensioned according to the nominal input current of the drive given in the rating table on page [115](#), the fuses will protect also the input cable in short-circuit situations, restrict drive damage and prevent damage to adjoining equipment in case of a short-circuit inside the drive. No separate fuses for the input cable protection are needed.

**Note 2:** Circuit breakers must not be used without fuses.

### Protecting the motor and motor cable in short-circuits

The drive protects the motor cable and motor in a short-circuit situation when the motor cable is dimensioned according to the nominal current of the drive. No additional protection devices are needed.

## Protecting the drive and the input power and motor cables against thermal overload

The drive protects itself and the input and motor cables against thermal overload when the cables are dimensioned according to the nominal current of the drive. No additional thermal protection devices are needed.



---

**WARNING!** If the drive is connected to multiple motors, a separate thermal overload switch or a circuit breaker must be used for protecting each cable and motor. These devices may require a separate fuse to cut off the short-circuit current.

---

## Protecting the motor against thermal overload

According to regulations, the motor must be protected against thermal overload and the current must be switched off when overload is detected. The drive includes a motor thermal protection function that protects the motor and switches off the current when necessary. Depending on a drive parameter value, the function either monitors a calculated temperature value (based on a motor thermal model) or an actual temperature indication given by motor temperature sensors. The user can tune the thermal model further by feeding in additional motor and load data.

The most common temperature sensors are:

- motor sizes IEC180...225: thermal switch, eg, Klixon
- motor sizes IEC200...250 and larger: PTC or Pt100.

See the *Firmware Manual* for more information on the motor thermal protection, and the connection and use of the temperature sensors.

## Protecting the drive against ground faults

The drive is equipped with an internal ground fault protective function to protect the unit against ground faults in the motor and motor cable. This is not a personal safety or a fire protection feature. The ground fault protective function can be disabled with a parameter, refer to the *Firmware Manual*.

Measures for protection in case of direct or indirect contact, such as separation from the environment by double or reinforced insulation or isolation from the supply system by a transformer, can be applied.

## Residual current device compatibility

The drive is suitable to be used with residual current devices of Type B.

**Note:** The EMC filter of the drive includes capacitors connected between the main circuit and the frame. These capacitors and long motor cables increase the ground leakage current and may cause fault current circuit breakers to function.

## Implementing the Emergency stop function

For safety reasons, install the emergency stop devices at each operator control station and at other operating stations where emergency stop may be needed.

**Note:** Pressing the stop key (  ) on the control panel of the drive does not generate an emergency stop of the motor or separate the drive from dangerous potential.

## Implementing the Safe torque off function

The drive supports the Safe torque off function according to standards EN 61800-5-2:2007; EN ISO 13849-1:2008, IEC 61508, IEC 61511:2004 and EN 62061:2005. The function also corresponds to prevention of unexpected start-up of EN 1037.

The Safe torque off function disables the control voltage of the power semiconductors of the drive output stage, thus preventing the inverter from generating the voltage required to rotate the motor (see diagram below). By using this function, short-time operations (like cleaning) and/or maintenance work on non-electrical parts of the machinery can be performed without switching off the power supply to the drive.

Start up and validate the Safe torque off function according to *ACSM1*, *ACS850* and *ACQ810 application guide* (3AFE68929814 [English]). The manual includes the safety data for the function.

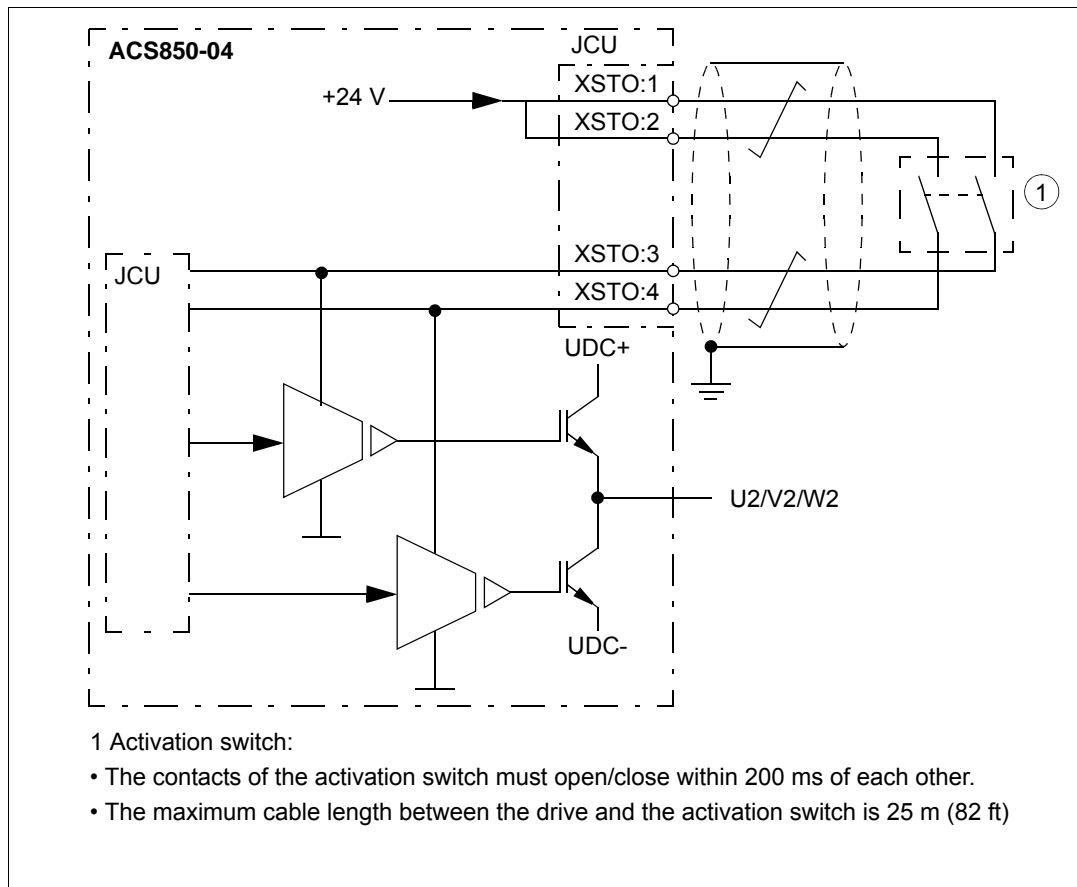

**WARNING!** The Safe torque off function does not disconnect the voltage of the main and auxiliary circuits from the drive. Therefore maintenance work on electrical parts of the drive or the motor may only be carried out after isolating the drive system from the main supply.

**Note:** It is not recommended to stop the drive by using the Safe torque off function. If a running drive is stopped by using the Safe torque off function, the drive will stop by coasting. If this is not acceptable eg, causes danger, the drive and machinery must be stopped using the appropriate stopping mode before using this function.

**Note concerning permanent magnet motor drives in case of a multiple IGBT power semiconductor failure:** In spite of the activation of the Safe torque off function, the drive system can produce an alignment torque which maximally rotates the motor shaft by  $180/p$  degrees.  $p$  denotes the pole pair number.

## Implementing the ATEX-certified Safe motor disconnection function (option +Q971)

With option +Q971, the drive provides ATEX-certified safe motor disconnection without contactor using the drive Safe torque off function. For more information, see *ACS850 ATEX-certified Safe disconnection function application guide* (3AUA0000074343 [English]).

## Implementing the Power loss ride-through function

Implement the power loss ride-through function as follows:

1. Activate the power loss ride-through function of the drive (parameter 47.02 UNDERVOLTAGE CTRL in the Standard Control Program).
2. If the installation is equipped with a main contactor, prevent its tripping at the input power break. For example, use a time delay relay (hold) in the contactor control circuit.



**WARNING!** Make sure that the flying restart of the motor will not cause any danger. If you are in doubt, do not implement the power-loss ride-through function.

---

## Using power factor compensation capacitors with the drive

Power factor compensation is not needed with AC drives. However, if a drive is to be connected in a system with compensation capacitors installed, note the following restrictions.



**WARNING!** Do not connect power factor compensation capacitors or harmonic filters to the motor cables (between the drive and the motor). They are not meant to be used with AC drives and can cause permanent damage to the drive or themselves.

---

If there are power factor compensation capacitors in parallel with the three phase input of the drive:

1. Do not connect a high-power capacitor to the power line while the drive is connected. The connection will cause voltage transients that may trip or even damage the drive.
2. If capacitor load is increased/decreased step by step when the AC drive is connected to the power line, ensure that the connection steps are low enough not to cause voltage transients that would trip the drive.
3. Check that the power factor compensation unit is suitable for use in systems with AC drives, ie, harmonic generating loads. In such systems, the compensation unit should typically be equipped with a blocking reactor or harmonic filter.

## Implementing a safety switch between the drive and motor

It is recommended to install a safety switch between the permanent magnet synchronous motor and the drive output. The switch is needed to isolate the motor during any maintenance work on the drive.

## Using a contactor between the drive and the motor

Arrange the control of the output contactor by applying one of the alternatives described below.

Alternative 1: When you have selected to use the default motor control mode (DTC) and motor coast stop in the drive, open the contactor as follows:

1. Give a stop command to the drive.
2. Open the contactor.

Alternative 2: When you have selected to use the default motor control mode (DTC) and motor ramp stop in the drive, open the contactor as follows:

1. Give a stop command to the drive.
2. Wait until the drive decelerates the motor to zero speed.
3. Open the contactor.

Alternative 3: When you have selected to use the scalar motor control mode in the drive, open the contactor as follows:

1. Give a stop command to the drive.
2. Open the contactor.



**WARNING!** When you have the default motor control mode (DTC) in use, never open the output contactor while the drive rotates the motor. The DTC motor control operates extremely fast, much faster than it takes for the contactor to open its contacts. When the contactor starts opening while the drive rotates the motor, the DTC will try to maintain the load current by immediately increasing the drive output voltage to the maximum. This will damage, or even burn the contactor completely.

---

## Implementing a bypass connection

If bypassing is required, employ mechanically or electrically interlocked contactors between the motor and the drive and between the motor and the power line. Ensure with interlocking that the contactors cannot be closed simultaneously.



**WARNING!** Never connect the supply power to the drive output terminals U2, V2 and W2. Line voltage applied to the output can result in permanent damage to the unit.

---

### Example bypass connection

An example bypass connection is shown below.

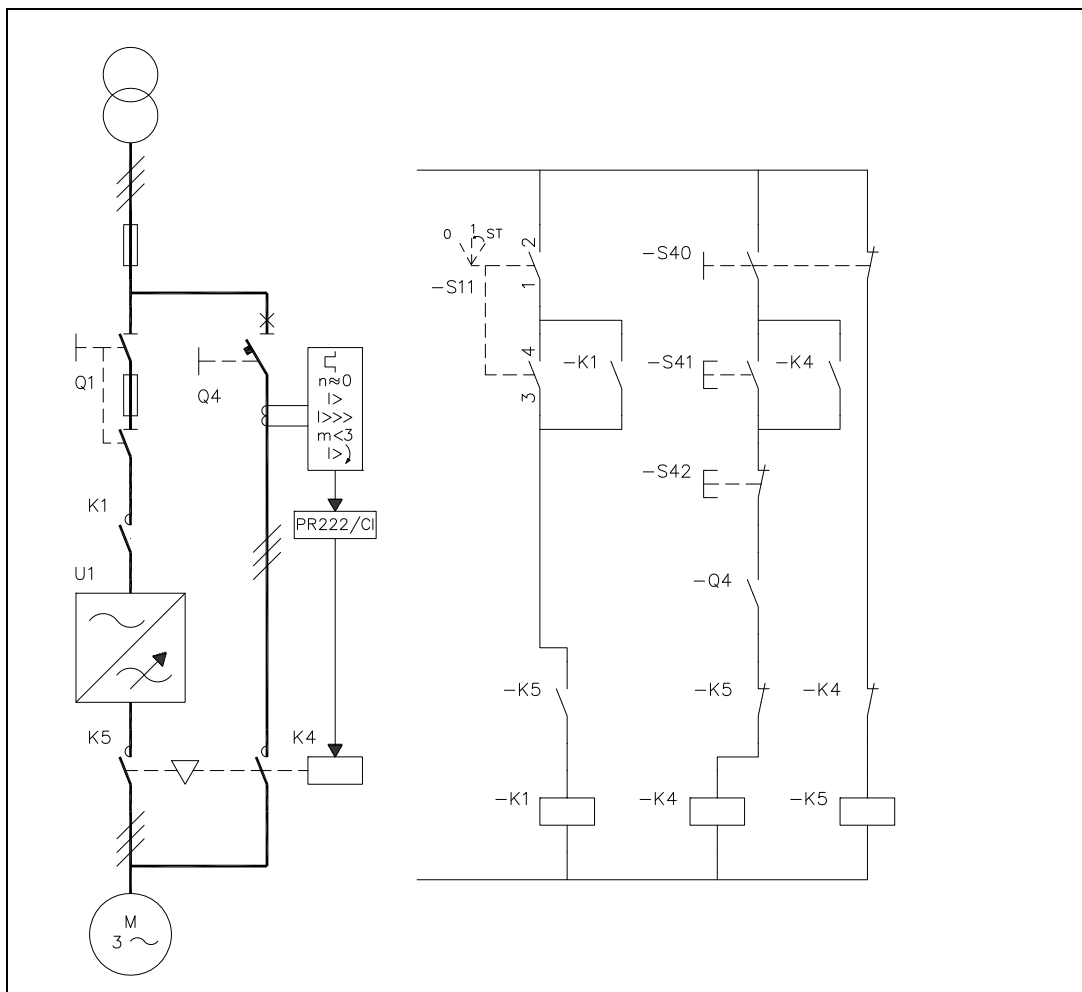

Switch	Description
Q1	Drive main switch
Q4	Bypass circuit breaker
K1	Drive main contactor
K4	Bypass contactor
K5	Drive output contactor
S11	Drive main contactor on/off control
S40	Motor power supply selection (drive or direct-on-line)
S41	Start when motor is connected direct-on-line
S42	Stop when motor is connected direct-on-line

#### *Switching the motor power supply from drive to direct-on-line*

1. Stop the drive and the motor with the drive control panel (drive in the local control mode) or the external stop signal (drive in the remote control mode).
2. Open the main contactor of the drive with S11.
3. Switch the motor power supply from the drive to direct-on-line with S40.
4. Wait for 10 seconds to allow the motor magnetization to die away.
5. Start the motor with S41.

#### *Switching the motor power supply from direct-on-line to drive*

1. Stop the motor with S42.
2. Switch the motor power supply from direct-on-line to the drive with S40.
3. Close the main contactor of the drive with switch S11 (-> turn to position ST for two seconds and leave to position 1).
4. Start the drive and the motor with the drive control panel (drive in the local control mode) or the external start signal (drive in the remote control mode).

## **Protecting the contacts of relay outputs**

Inductive loads (relays, contactors, motors) cause voltage transients when switched off.

The relay contacts on the JCU Control Unit are protected with varistors (250 V) against overvoltage peaks. In spite of this, it is highly recommended to equip inductive loads with noise attenuating circuits (varistors, RC filters [AC] or diodes [DC]) in order to minimize the EMC emission at switch-off. If not suppressed, the disturbances may connect capacitively or inductively to other conductors in the control cable and form a risk of malfunction in other parts of the system.

Install the protective component as close to the inductive load as possible. Do not install protective components at the relay outputs.

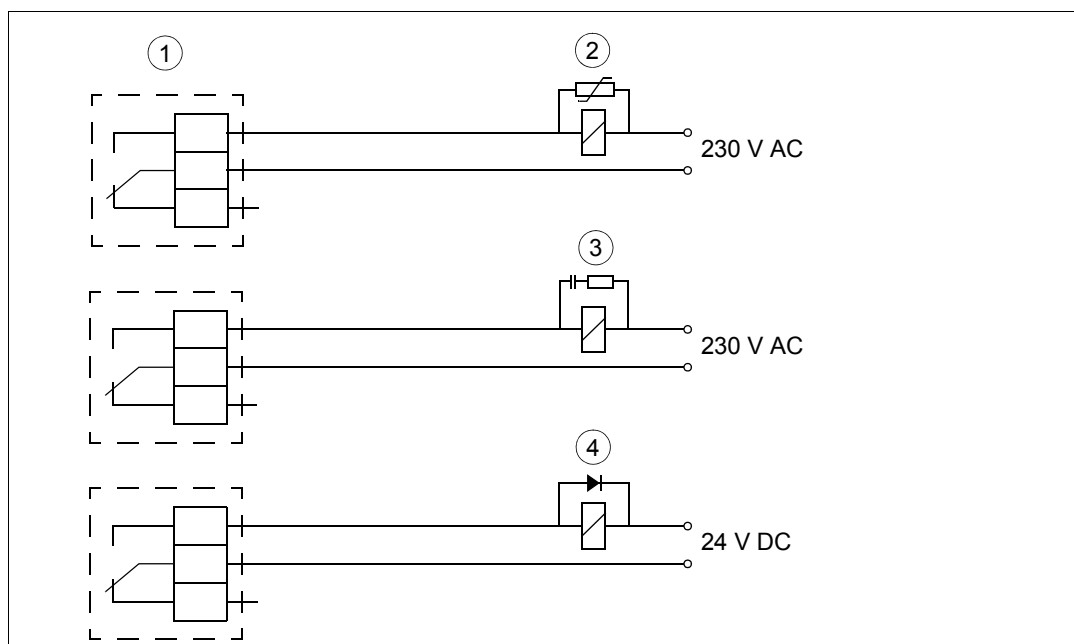

1) Relay outputs; 2) Varistor; 3) RC filter; 4) Diode

## Connecting a motor temperature sensor to the drive I/O



**WARNING!** IEC 60664 requires double or reinforced insulation between live parts and the surface of accessible parts of electrical equipment which are either non-conductive or conductive but not connected to the protective earth.

To fulfil this requirement, the connection of a thermistor (and other similar components) to the digital inputs of the drive can be implemented in three alternate ways:

1. There is double or reinforced insulation between the thermistor and live parts of the motor.
2. Circuits connected to all digital and analog inputs of the drive are protected against contact and insulated with basic insulation (the same voltage level as the drive main circuit) from other low voltage circuits.
3. An external thermistor relay is used. The insulation of the relay must be rated for the same voltage level as the main circuit of the drive. For connection, see *Firmware Manual*.

## Example circuit diagram

See page [134](#).



# Installation

---

## What this chapter contains

In this chapter, the drive module is installed in a 400 mm wide Rittal TS 8 cabinet in a bookshelf way of mounting: The module is placed in an upright position on the cabinet bottom with its front facing the cabinet door. The following Rittal parts and drive module options are used in the installation examples:

Drive module standard parts		
<ul style="list-style-type: none"> <li>• Drive module</li> <li>• Top guide plate</li> <li>• Pedestal guide plate</li> <li>• Telescopic extraction and insertion ramp</li> <li>• Fastening screws in a plastic bag</li> <li>• External control unit</li> </ul>		
Drive module options		
Option code	Qty (pcs)	Description
+H381	1	Power cabinet panels
+P905	1	Internal control unit
Rittal parts		
Rittal part code	Qty (pcs)	Description
TS 8406.510	1	Enclosure without mounting plate. Includes frame, door, side and back panels.
TS 8612.160	5	Punched section with mounting flange, outer mounting level for 600 mm horizontal
TS 8612.140	1	Punched section with mounting flange, outer mounting level for 400 mm horizontal
3243.200	2	Air filter 323 mm × 323 mm
Customer-defined parts		
Cabinet bottom plate	1	The customer must provide a bottom plate to the cabinet for ensuring the degree of protection.
Cabinet grounding busbar	1	The customer must provide a cabinet grounding busbar in this installation example.

Always follow the general rules given in this chapter and local laws and regulations. ABB does not assume any liability whatsoever for any installation which breaches local laws and/or other regulations.

**Note 1:** The drive module can also be installed in other than Rittal TS 8 cabinets.

**Note 2:** With input and motor cables of size  $4 \times 240 \text{ mm}^2$  per phase, DC cables cannot be lead to the terminals of the input cabling panel through the input cabling panel lead-throughs. Lead the DC cables then through the cabinet roof directly to the terminals. If resistor cables are to be connected, the lower side plate of the output cabling panel must be removed and the resistor cables lead from side to the terminals of the output cabling panel.

**Note 3:** In addition to the installation examples presented in this chapter, there are a few alternative installation means, such as:

- The power cables can be connected directly to the drive module input and output terminals with cable lugs or by busbars. The drive module can also be fastened selfstanding to the floor in an electrical equipment room when the power cable terminals and electrical parts are protected against contact and the unit is grounded properly.
- The drive module without pedestal (option +0H354) can be fastened to wall or cabinet with four screws through the fastening holes at the top and bottom of the right-hand side of the module.

## Safety



---

**WARNING!** Only qualified electricians are allowed to carry out the electrical installation work described in this chapter. Follow the [Safety instructions](#) on the first pages of this manual. Ignoring the safety instructions can cause injury or death.

---

## Checking the installation site

The material below the drive must be non-flammable and strong enough to carry the weight of the drive.

See section [Ambient conditions](#) on page 122 for the allowed ambient conditions and section [Losses, cooling data and noise](#) on page 117 for the required cooling air.

## Required tools

- Set of screw drivers
- Torque wrench with a 500 mm (20 in.) or  $2 \times 250 \text{ mm}$  ( $2 \times 10 \text{ in.}$ ) long extension bar
- 17 mm (11/16 in.) magnetic-end socket for fastening the drive module busbars to the optional cabling panels (+H381)
- 10 mm magnetic-end socket or a torx screw driver for fastening the drive module top fastening bracket to the cabinet back and for fastening the optional cabling panels (+H381) to the cabinet side panels
- 13 mm socket for fastening the drive module to the cabinet bottom plate or floor
- 22 mm magnetic-end socket for fastening the cable lugs to the terminals (M12 bolt).

## Moving and unpacking the unit



**WARNING!** Follow the safety instructions, page 12. Ignoring the instructions can cause physical injury or death, or damage to the equipment

Move the transport package by pallet truck to the installation site.

Unpack the package as follows:

- Cut the bands (A).
- Unpack the additional boxes (B).
- Remove the outer sheathing by lifting it (C).
- Remove the sheathing by lifting it (D).
- Fasten lifting hooks to the drive module lifting eyes and lift the module to the installation place.

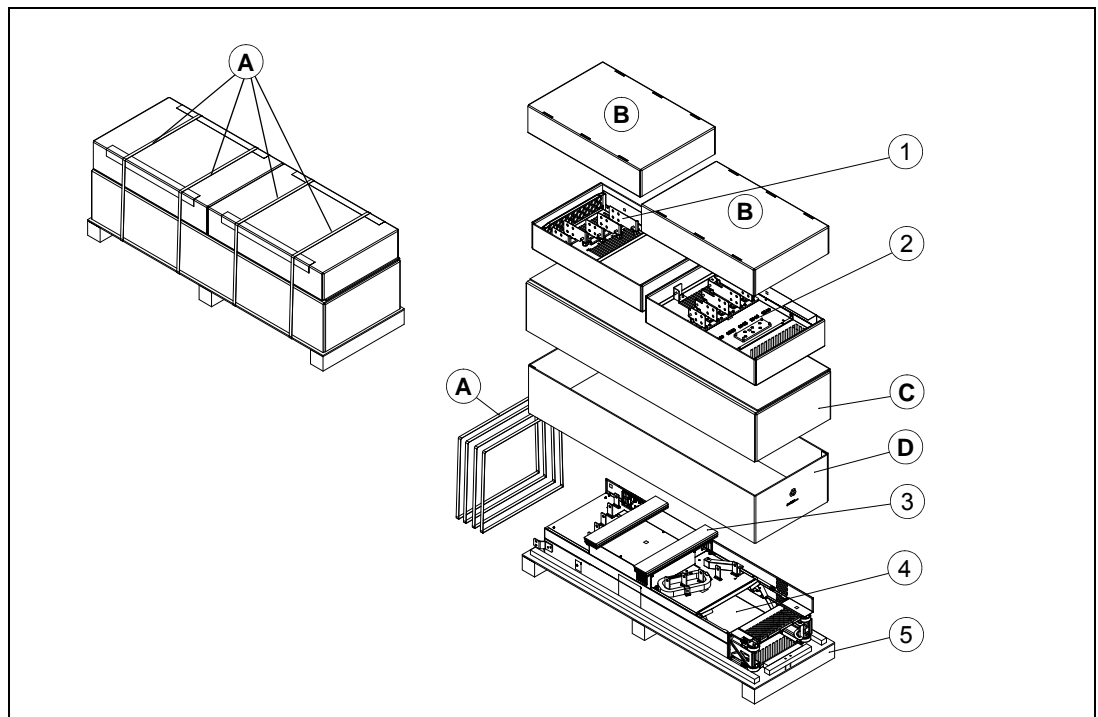

Description of the package contents	
1	Input cabling panel (option +H381), top guide plate, pedestal guide plate, telescopic ramp, fastening screws in a plastic bag, external control unit with control cable clamp plate and factory installed optional modules, control panel with door mounting kit (option +J410), delivery documents, printed <i>Hardware Manual</i> and multilingual <i>Quick Start-up Guide</i> and manuals CD. Other printed manuals with options +R700 to +R714.
2	Output cabling panel (option +H381)
3	Plywood support
4	Drive module with factory installed options and multilingual residual voltage warning sticker
5	Pallet

## Checking the delivery

Check that all items listed under section *Moving and unpacking the unit* are present.

Check that there are no signs of damage. Before attempting installation and operation, check the information on the type designation label of the drive to verify that the unit is of the correct type.

## Checking the insulation of the assembly

### Drive

Do not make any voltage tolerance or insulation resistance tests (e.g. hi-pot or megger) on any part of the drive as testing can damage the drive. Every drive has been tested for insulation between the main circuit and the chassis at the factory. Also, there are voltage-limiting circuits inside the drive which cut down the testing voltage automatically.

### Input cable

Check the insulation of the input cable according to local regulations before connecting it to the drive.

### Motor and motor cable

Check the insulation of the motor and motor cable as follows:

1. Check that the motor cable is disconnected from the drive output terminals U2, V2 and W2.
2. Measure the insulation resistance between each phase conductor and the Protective Earth conductor using a measuring voltage of 500 V DC. The insulation resistance of an ABB motor must exceed 100 Mohm (reference value at 25 °C or 77 °F). For the insulation resistance of other motors, please consult the manufacturer's instructions. **Note:** Moisture inside the motor casing will reduce the insulation resistance. If moisture is suspected, dry the motor and repeat the measurement.

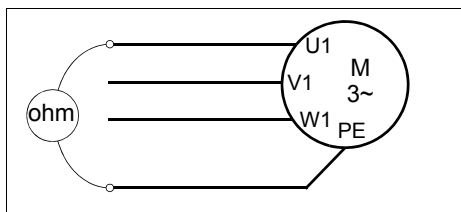

## Brake resistor and resistor cable

Check the insulation of the brake resistor assembly (if present) as follows:

1. Check that the resistor cable is connected to the resistor, and disconnected from the drive output terminals R+ and R-.
2. At the drive end, connect the R+ and R- conductors of the resistor cable together. Measure the insulation resistance between the conductors and the PE conductor by using a measuring voltage of 1 kV DC. The insulation resistance must be higher than 1 Mohm.

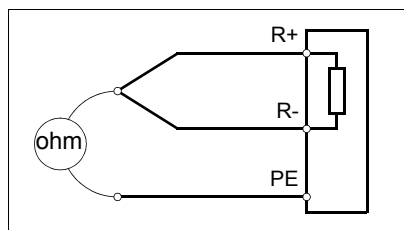

## Overall flowchart of the installation process

This flowchart describes the installation process of the units listed under [What this chapter contains](#) on page 69.

Step	Task	For instructions, see
1	Install the Rittal parts, cabinet bottom plate, drive bottom guide plate and top guide and loose drive options (cabling panels, option +H381) in the drive module cubicle.	<a href="#">Installing the mechanical accessories into the cabinet</a> , page 73
2	Install the auxiliary components (such as mounting plates, air baffles, switches, busbars etc.).	The component manufacturer's instructions <a href="#">Layout examples, door open</a> , page 37
3	Connect the power cables to the cabling panels.	<a href="#">Connecting the power cables</a> , page 75
4	Mount the drive module into the cabinet.	<a href="#">Mounting the drive module into the cabinet</a> , page 80
5	<u>Drive modules with an external control unit:</u> Mount the external control unit.	<a href="#">Mounting the external control unit</a> , page 87
6	Connect the control cables.	<a href="#">Connecting the power cables</a> , page 83
7	Install the remaining parts, for example, cabinet doors, side plates, etc.	The component manufacturer's instructions

## Installing the mechanical accessories into the cabinet

Install the cabling panels (option +H381), bottom plate, grounding busbar, bottom guide plate, top guide and Rittal parts into the cabinet according to the following assembly drawing and the dimension drawing on page 131.

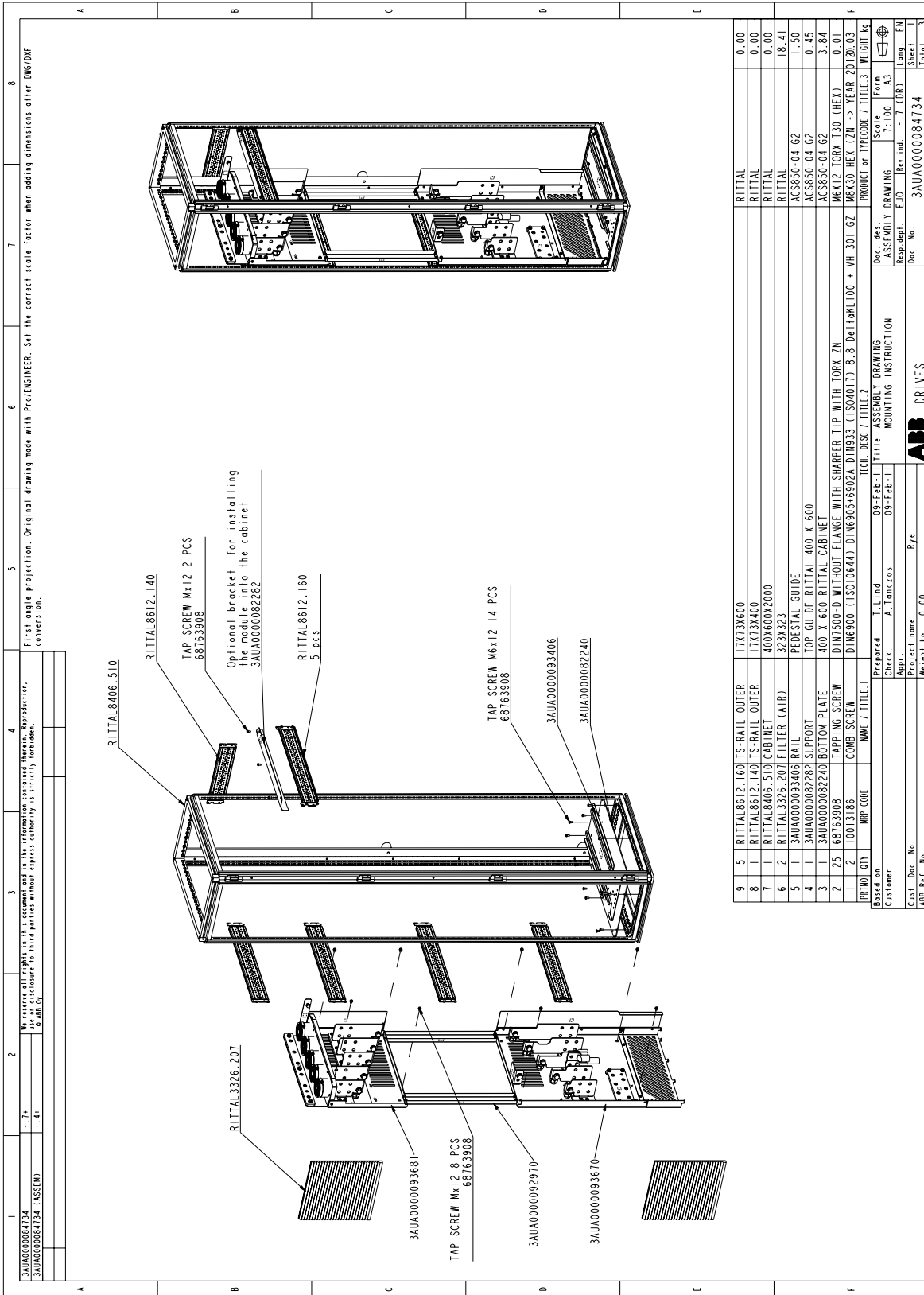

QTY	WPP CODE	NAME / TITLE.1	Prepared	T.Lind	09-Feb-11	ASSEMBLY DRAWING	Score	Form	Weight kg
9		RITTAL8612_160 IS-RAIL OUTER	17X73X600			RITTAL	0.00		
8		RITTAL8612_140 IS-RAIL OUTER	17X73X400			RITTAL	0.00		
7		RITTAL8406_510 CABINET	400X600X2000			RITTAL	0.00		
6		RITTAL3326_207 FILTER (AIR)	323X323			RITTAL	18.41		
5		3AUA0000093406 RAIL	PEDESTAL GUIDE			ACS850-04 G2	1.50		
4		3AUA0000082282 SUPPORT	TOP GUIDE RITTAL 400 X 600			ACS850-04 G2	0.45		
3		3AUA0000082240 BOTTOM PLATE	400 X 600 RITTAL CABINET			ACS850-04 G2	3.84		
2	25	68763908 TAPPING SCREW	DIN7500-D WITHOUT FLANGE WITH SHARPER TIP WITH TORX ZN			M6X12 TORX T30 (HEX)	0.01		
1	2	10013186 COMBI SCREW	DIN6900 (ISO.0644) DIN6905+6902A DIN933 (ISO4017) 8.8 DeHAKL00 + VH_30_GZ M8X30 HEX (ZN -> YEAR 2012).03			PRODUCT or TYPECODE / TITLE.3			
Based on: I.Lind 09-Feb-11 Title: ASSEMBLY DRAWING Customer: A.Lanczos 09-Feb-11 MOUNTING INSTRUCTION Project name: Rye Weight kg: 0.00 Doc. No.: 3AUA0000084734 Sheet: 1 of 3									

## Connecting the power cables



**WARNING!** Follow the safety instructions, page 12. Ignoring the instructions can cause physical injury or death, or damage to the equipment

### Connection diagram

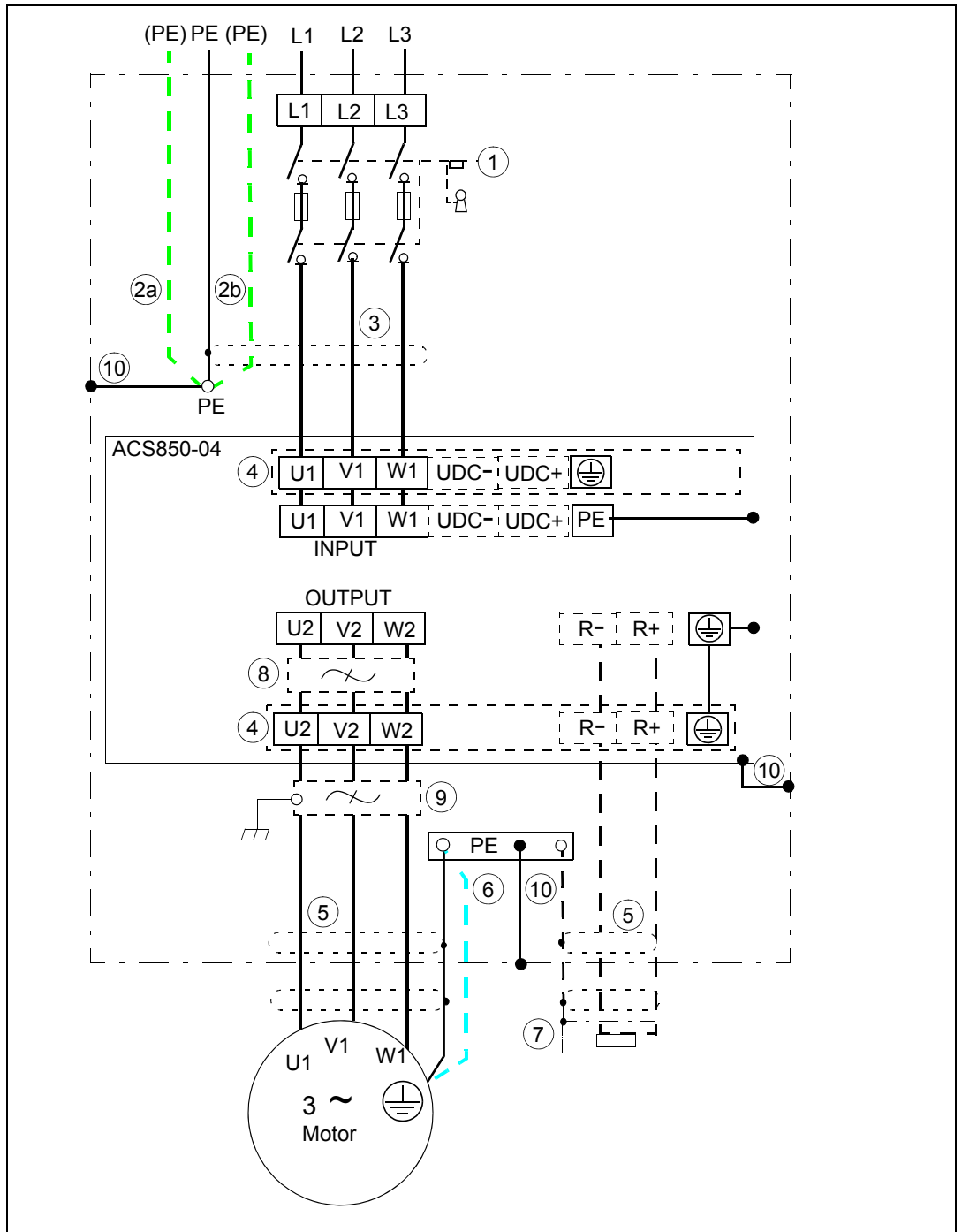

1	For alternatives, see section <a href="#">Selecting the supply disconnecting device (disconnecting means)</a> on page 47. In the mounting example of this chapter, the disconnecting device is not in the same cubicle with the drive module.
2	If a shielded cable is used (not required but recommended) and the conductivity of the shield is < 50% of the conductivity of the phase conductor, use a separate PE cable (2a) or a cable with a grounding conductor (2b).
3	360-degree grounding is recommended at the cabinet entry if a shielded cable is used. Ground the other end of the input cable shield or PE conductor at the distribution board.
4	Input and output power cabling panels (option +H318).
5	360-degree grounding at the cabinet entry is recommended, see page 39.
6	Use a separate grounding cable if the conductivity of the cable shield is < 50% of the conductivity of the phase conductor and there is no symmetrically constructed grounding conductor in the cable (see page 54).
7	External brake resistor, see page 135.
8	Common mode filter (option +E208), see page 49.
9	du/dt filter (optional, see page 141).
10	The drive module frame and the cabinet PE (ground) busbar must be connected to the cabinet frame. See section <a href="#">Arranging the grounding inside the cabinet</a> on page 38.
<p><b>Note:</b></p> <p>If there is a symmetrically constructed grounding conductor in the motor cable in addition to the conductive shield, connect the grounding conductor to the grounding terminal at the drive and motor ends.</p> <p>Do not use an asymmetrically constructed motor cable. Connecting its fourth conductor at the motor end increases bearing currents and causes extra wear.</p>	

## Input cable connection procedure



**WARNING!** Follow the instructions in chapter [Safety instructions](#). Ignoring the instructions can cause physical injury or death, or damage to the equipment.

1. Lead the cables into the inside of the cabinet. It is recommended to apply 360° grounding of the cable shields at the lead-through plate.
2. Twist the cable shields into bundles and connect them to cabinet PE (ground) busbar. Connect any separate ground conductors or cables to cabinet PE (ground) busbar.
3. Connect the phase conductors to terminals U1, V1, W1 of the input cabling panel. For the tightening torques, see page [117](#).

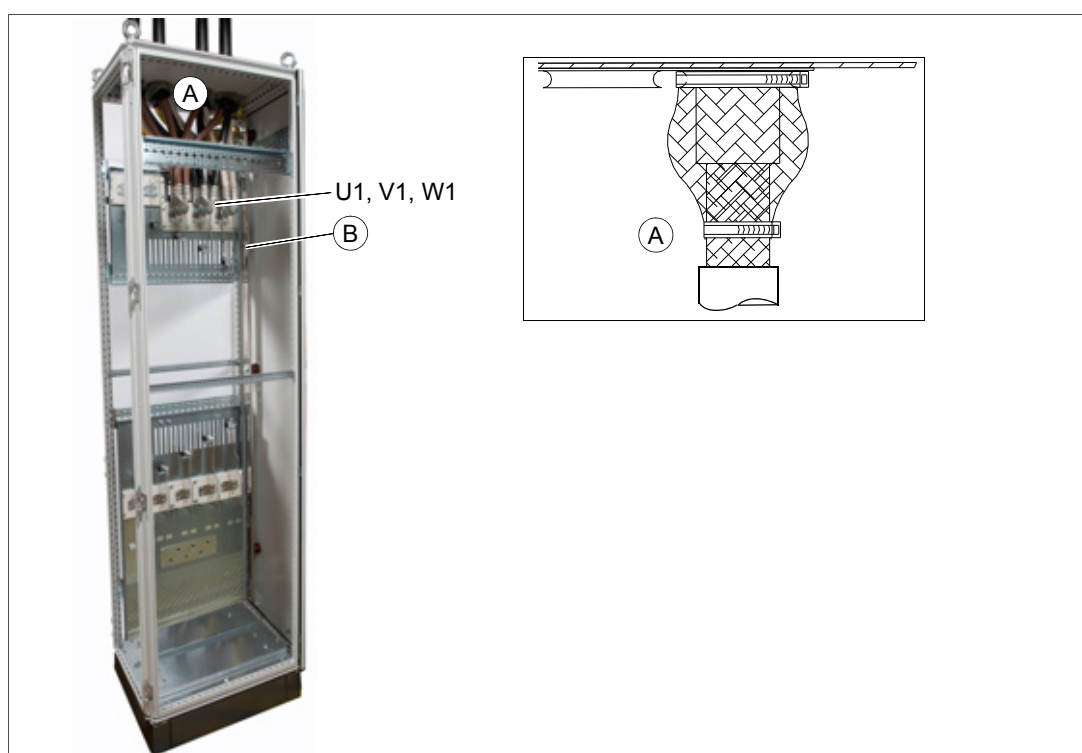

View without cabinet side plates or door in place. A) 360-degree grounding at the cabinet lead-through plate; B) PE (ground) busbar of the cabinet

## Motor cable connection procedure



**WARNING!** Follow the instructions in chapter [Safety instructions](#). Ignoring the instructions can cause physical injury or death, or damage to the equipment.

1. Lead the cables into the inside of the cabinet. Ground the cable shield 360° at the lead-through plate.
2. Twist the cable shields into bundles and connect them to cabinet PE (ground) busbar. Connect also the separate PE conductors or cable if any.
3. Connect the phase conductors to terminals U2, V2 and W2 of the output cabling panel. For the tightening torques, see page [117](#).

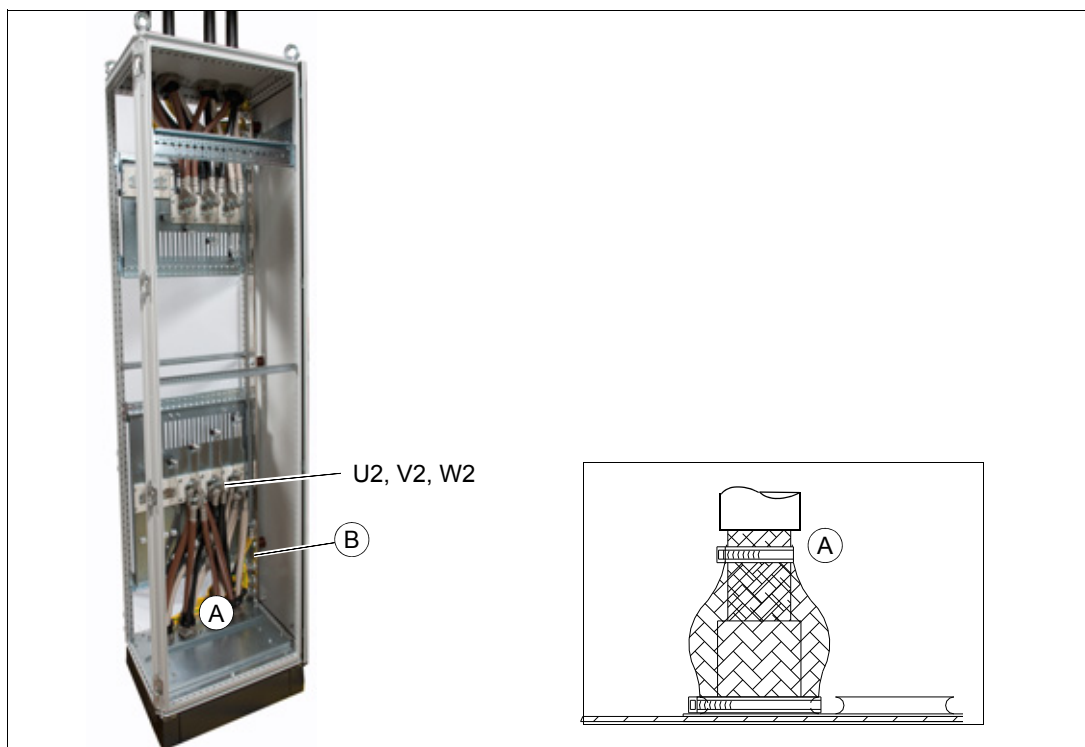

View without cabinet side plate or door in place. A) 360-degree grounding at the cabinet lead-through plate; B) PE (ground) busbar of the cabinet

Ground the motor cable shield at the motor end as follows:

- 360 degrees at the lead-through of the motor terminal box (1)

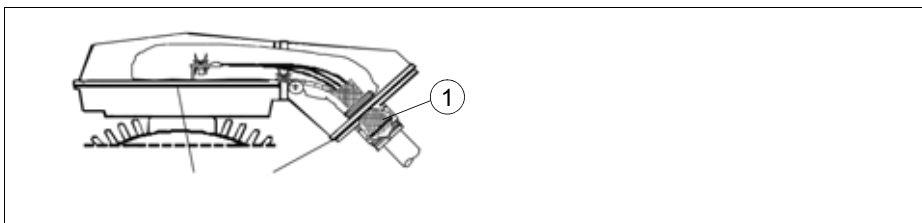

- or by twisting the shield as follows: flattened width  $\geq 1/5 \cdot \text{length}$ .

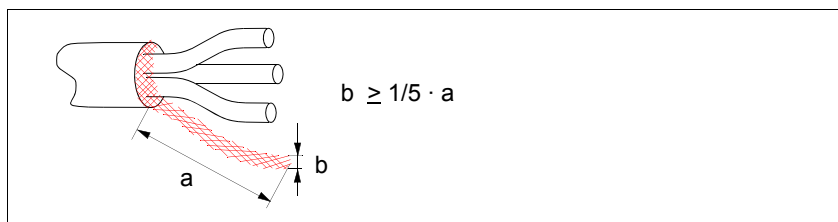

### DC connection

The UDC+ and UDC– terminals are intended for common DC configurations of a number of drives, allowing regenerative energy from one drive to be utilised by the other drives in the motoring mode. Contact your local ABB representative for further instructions.

## Mounting the drive module into the cabinet



**WARNING!** Follow the safety instructions, page 12. Ignoring the instructions can cause physical injury or death, or damage to the equipment.

Handle the drive module carefully. Make sure that the module does not fall down when moving it on the floor and during installation and maintenance work: Open the support legs by pressing each leg a little down and turning it aside (1, 2). When ever possible secure the module also with chains from top.

Do not tilt the drive module (A). It is **heavy** (over 200 kg [440 lb]) and its **center of gravity is high**. The module will overturn from a sideways tilt of 5 degrees. Do not leave the module unattended on a sloping floor.

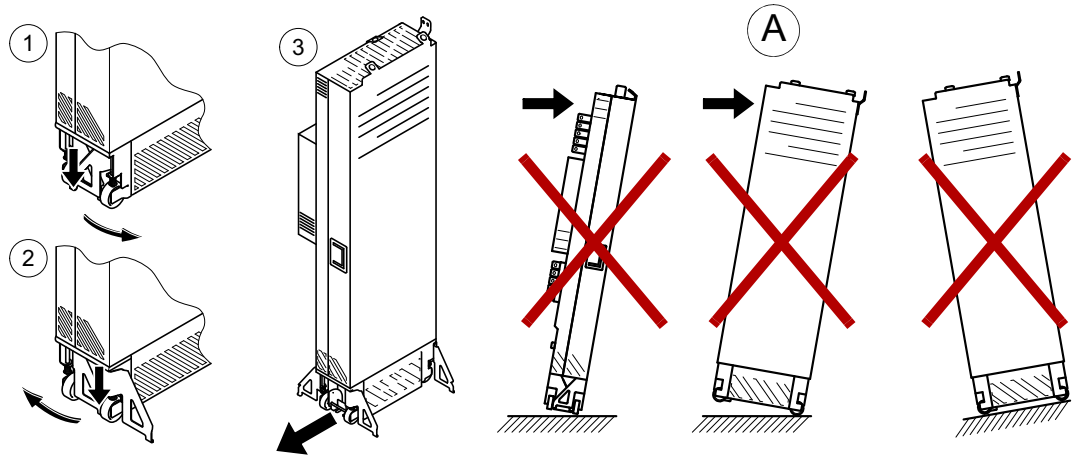

### Mounting procedure

1. Fasten the extraction and insertion ramp to the cabinet base with two screws.
2. Remove the upper and lower left-side front covers of the drive module. M4×8 combi screws, 2 Nm.
3. Push the drive module carefully into to the cabinet preferably with help from another person.
4. Fasten the busbars of the drive module to the busbars of the cabling panels. combi screw M12, 70 N·m (52 lbf·ft).
5. Fasten the drive module to the cabinet from top and bottom as shown below and in the assembly drawing on page 82. **Note:** The screws ground the module to the cabinet frame.
6. Units with external control unit: Replace the front covers of the drive module on the power cable sections.  
Units with internal control unit (option +P905): Replace the front covers of the drive module on the power cable sections after connecting the control cables to the control unit.

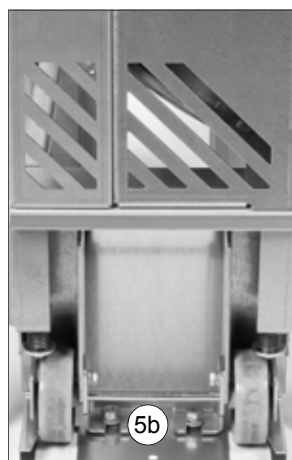
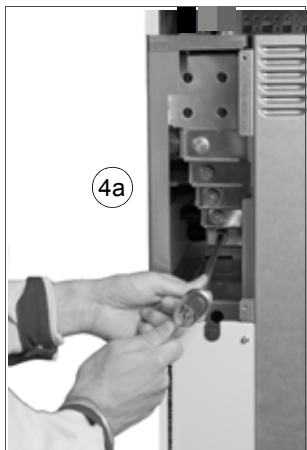
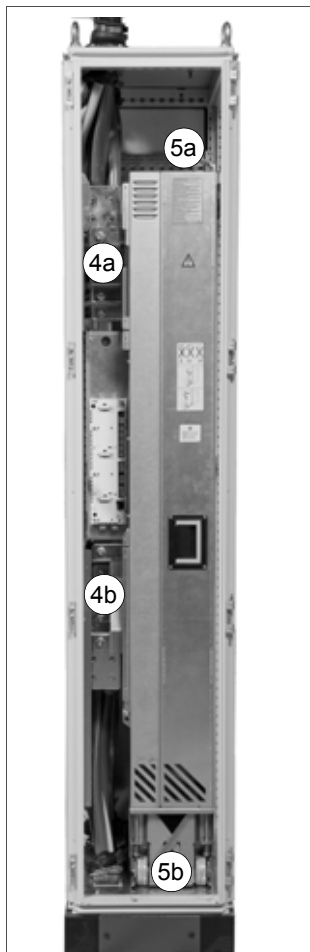
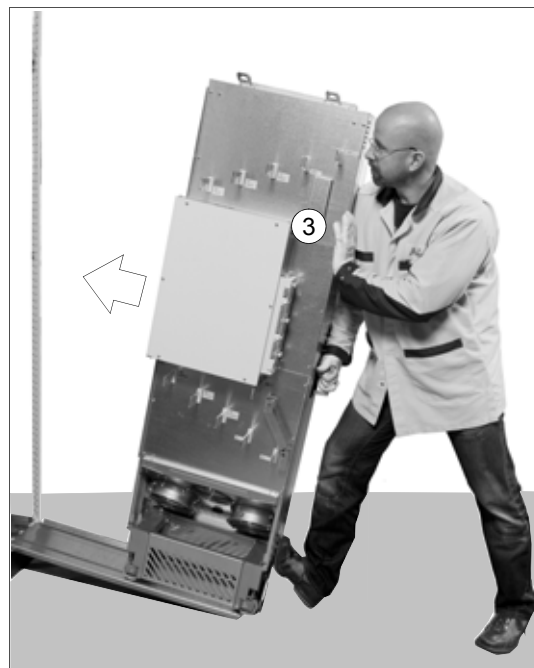

### Assembly drawing of fastening the drive module to the cabinet

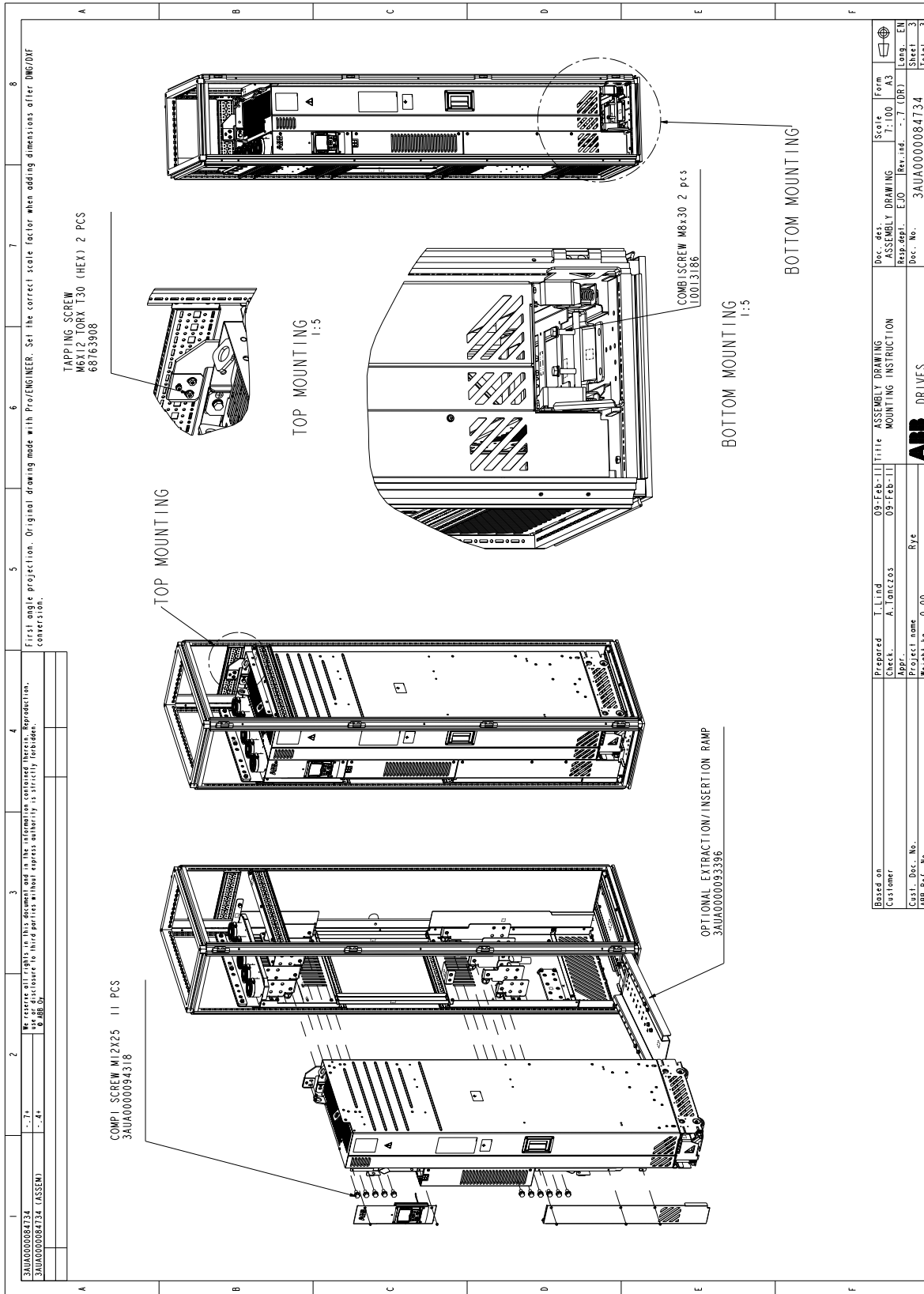

First angle projection. Original drawing made with Pro/ENGINEER. Set the correct scale factor when adding dimensions after DWG/DXF conversion.

We reserve all rights in this document and in the information contained therein. Reproduction, distribution or disclosure to third parties without express authority is strictly prohibited.

3AUJA000084734 (ASSEM)  
 3AUJA000084734 (ASSEM)

Doc. No.	3AUJA000084734	Form	A3
Scale	1:100	Form	A3
Doc. des.	ASSEMBLY DRAWING	Scale	1:100
Responsible	EJO	Rev. no.	1
Doc. No.	3AUJA000084734	Lang.	EN
Sheet	3	Sheet	3
Total	3	Total	3

Based on	T. Lind	Prepared	09-Feb-11	Title	ASSEMBLY DRAWING
Customer	A. Tarozzi	Check.	09-Feb-11	Mounting Instruction	
Proj. name	ABB DRIVES	Project name		Bye	
Weight kg	0.20	Weight kg	0.20		

## Removing the protective covering from the module air outlet



**WARNING!** Remove the protective covering from the top of the drive module after the installation. If the covering is not removed, the cooling air cannot flow freely through the module and the drive will run to overtemperature.



## Connecting the control cables

### Flowchart of the control cable installation process (external control unit)

Step	Task	For instructions, see section
1	Remove the cover assembly of the control unit.	<i>Removing the cover assembly of the external control unit, page 84</i>
2	Fasten the control cable clamp plate to the control unit.	<i>Fastening the control cable clamp plate, page 85</i>
3	Install the optional modules to the control unit (if not mounted yet).	<i>Installing optional modules, page 89</i>
4	Connect the power supply and fiber optic cables between the control unit and the drive module.	<i>Connecting the external control unit to the drive module, page 85</i>
5	Mount the control unit to the wall or DIN rail.	<i>Mounting the external control unit, page 87</i>
3	Connect the external control cables to the control unit and the optional modules.	<i>Connecting the control cables to the terminals of the control unit, page 90</i>
	Refit the control unit cover assembly	<i>Removing the cover assembly of the external control unit, page 84</i>

### Flowchart of the control cable installation process (internal control unit, option +P905)

Step	Task	For instructions, see section
1	Route the control cables inside the cabinet and connect them.	<i>Control cable connection procedure of units with internal control unit (option +P905), page 96</i>

### Removing the cover assembly of the external control unit

The cover assembly needs to be removed before the installation of optional modules and the connection of control cabling. Follow this procedure to remove the cover assembly. The numbers refer to the illustrations below.

1. Press the tab slightly with a screwdriver.
2. Slide the lower cover plate slightly downwards and pull it out.
3. Disconnect the panel cable if present.
4. Remove the fastening screw at the top of the cover assembly.
5. Carefully pull the lower part of the base outwards by the two tabs.
6. Refit the cover in reverse order to the above when the control cables have been connected.

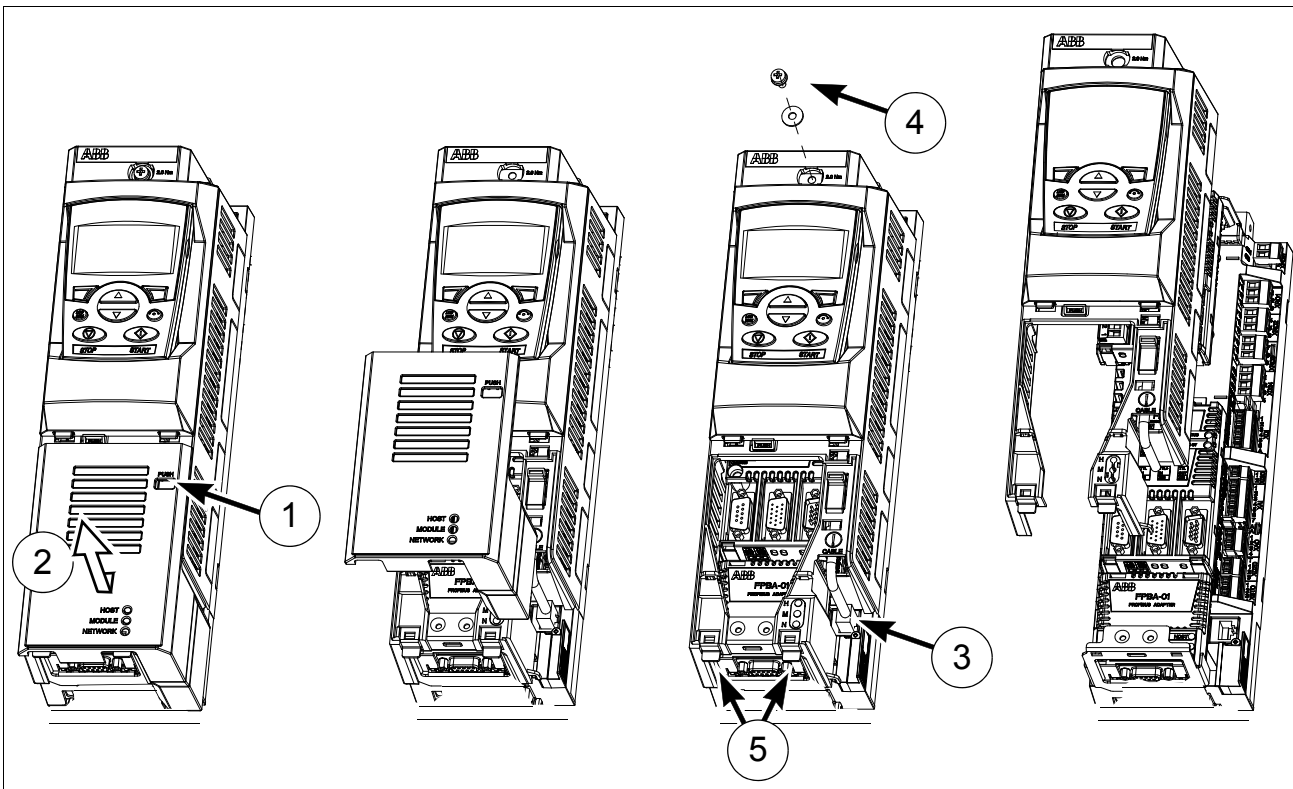

### Fastening the control cable clamp plate

Fasten the control cable clamp plate either to the top or base of the control unit with four screws as shown below.

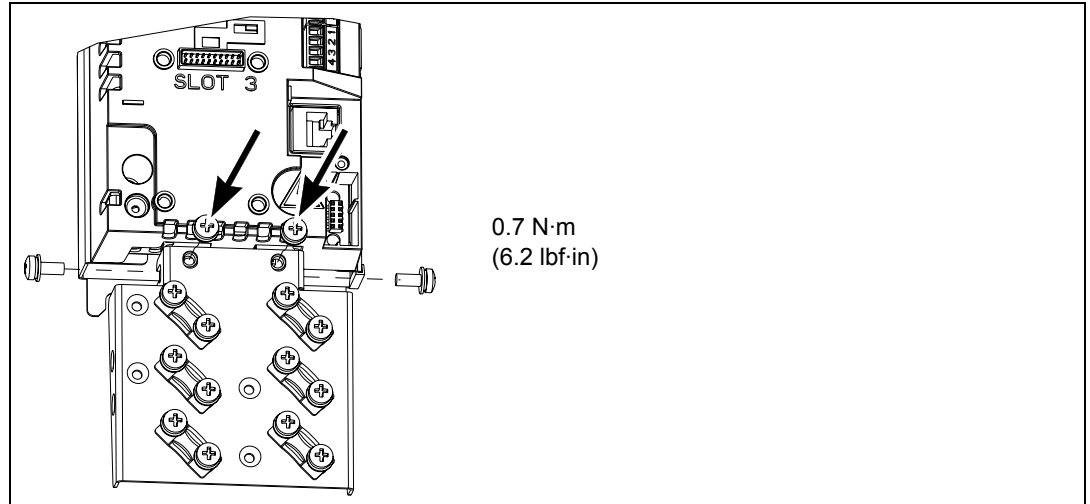

### Connecting the external control unit to the drive module



**WARNING!** Handle the fiber optic cables with care. When unplugging optic cables, always grab the connector, not the cable itself. Do not touch the ends of the fibers with bare hands as the fiber is extremely sensitive to dirt.

Connect the fiber optic cables and power supply cable coming from the drive module through the U-hole in the circuit board compartment cover to the external control unit as follows:

1. Thread the cables inside the back frame of the control unit as shown below.
2. Insert the fiber optic cables to the JRIB board terminals.
3. Connect the power supply wires to the JRIB board terminals.

Connection table	
APOW	JRIB
X3: 1	X202: 1
X3: 2	X202: 2
JINT	JRIB
V1	V1
V2	V2
JGDR	JRIB
V6	V6
V7	V7

4. Connect the APOW cable grounding wire to the grounding terminal at the back top or bottom of the control unit.

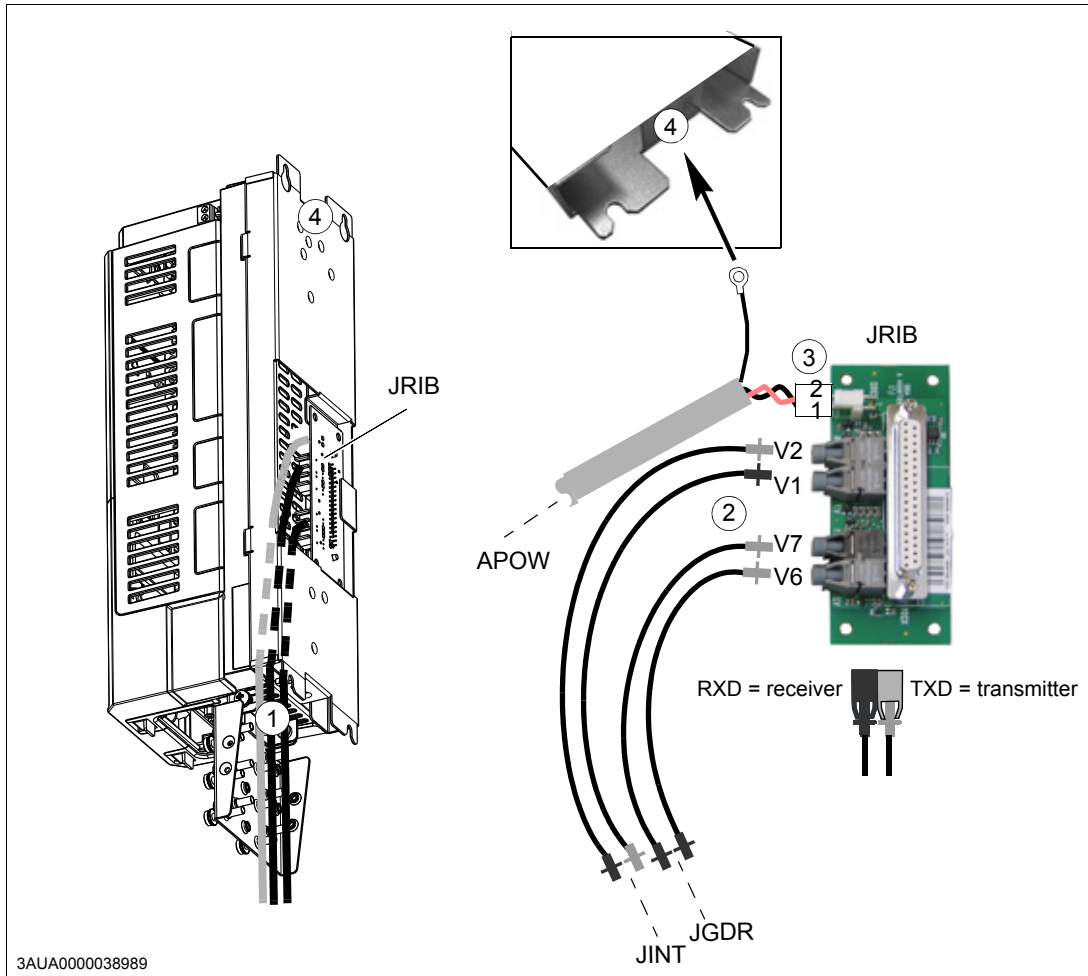

### Mounting the external control unit

The drive control unit can be fastened on a mounting plate through the fastening holes in its back or by using a DIN rail.

#### *Mounting the external control unit to wall*

1. Fasten the fastening screws in the wall.
2. Lift the unit onto the screws and tighten the screws.

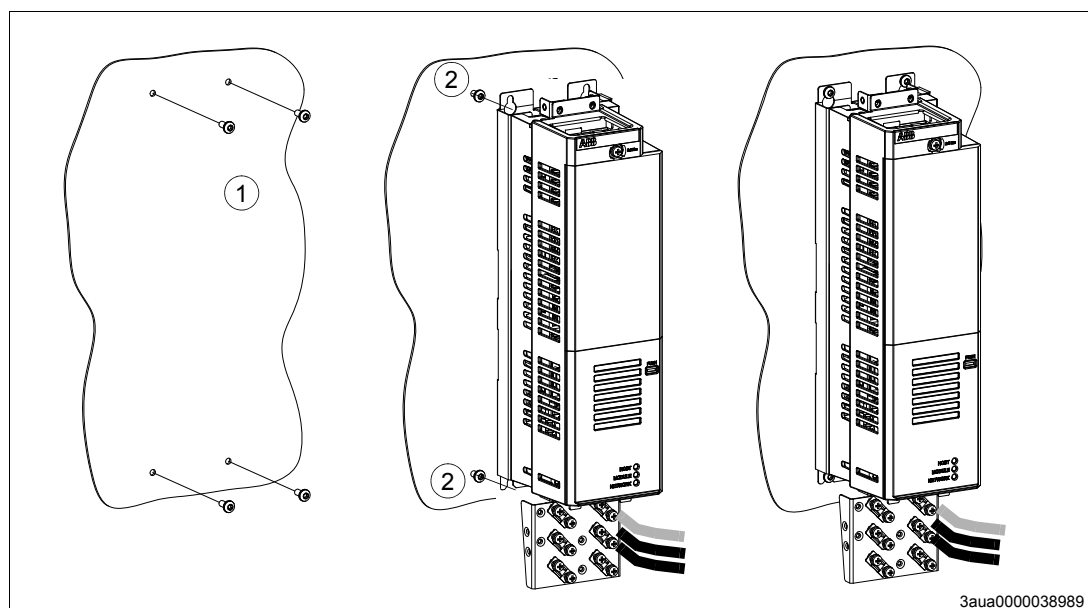

3aua0000038989

*Mounting the external control unit vertically on a DIN rail*

1. Fasten the latch (A) to the back of the control unit with four screws.
2. Click the control unit to the rail as shown below (B).

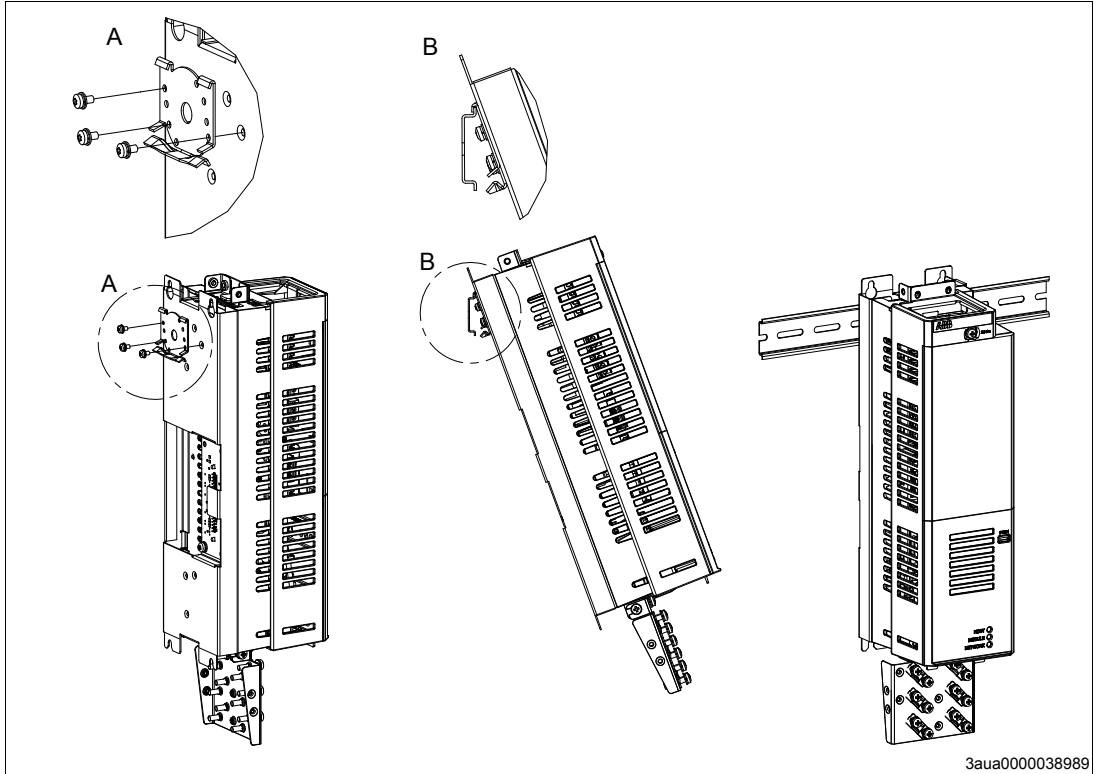

*Mounting the control unit horizontally on a DIN rail*

1. Fasten the latches (A) to the back of the control unit with four screws.
2. Click the control unit to the rail as shown below (B).

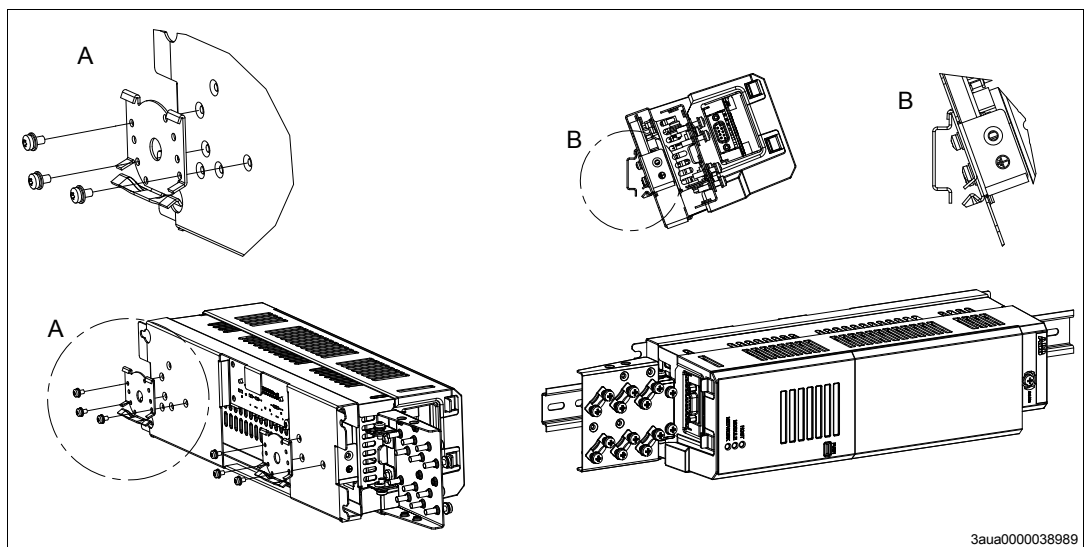

## Installing optional modules

### *Mechanical installation*

Optional modules such as a fieldbus adapters, an I/O extensions and the pulse encoder interfaces are inserted in the optional module slot on the control unit. See page 30 for the available slots.

1. Remove the control unit cover.
2. Remove the protective cover (if present) from the connector of the slot.
3. Insert the module carefully into its position on the control unit.
4. Fasten the screw.

**Note:** Correct installation of the screw is essential for fulfilling the EMC requirements and for proper operation of the module.

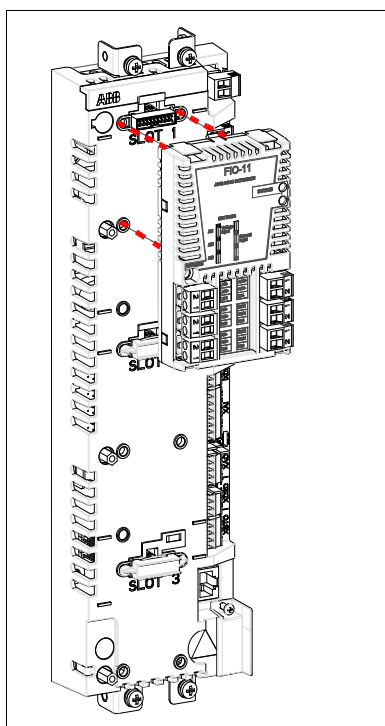

### *Wiring the modules*

See the appropriate optional module manual for specific installation and wiring instructions. See page 90 for routing the cables.

## Connecting the control cables to the terminals of the control unit

1. Route the cables to the control unit as shown below.

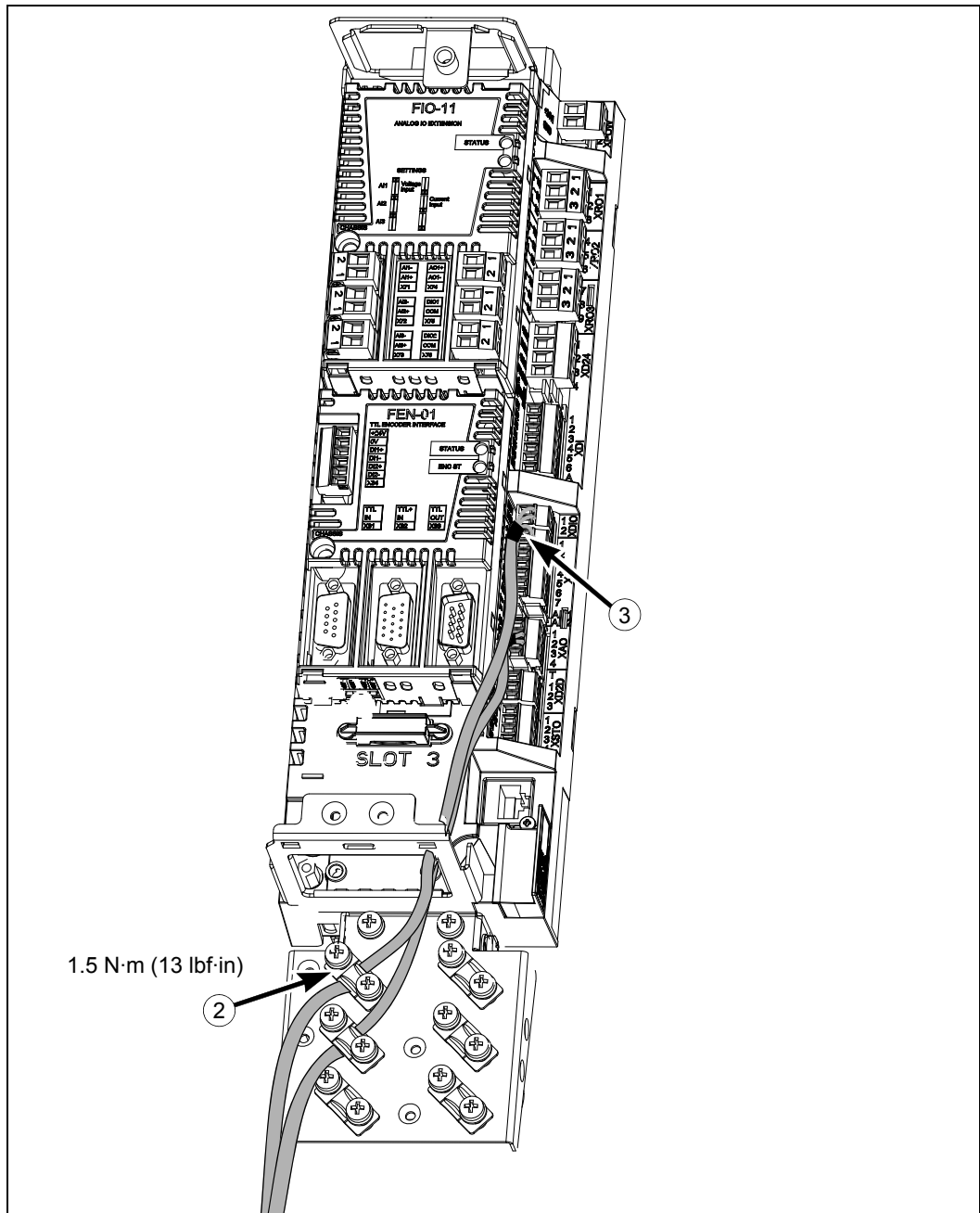

2. Ground the shields of the control cables at the clamp plate. The shields should be continuous as close to the terminals of the control unit as possible. Only remove the outer jacket of the cable at the cable clamp so that the clamp presses on the bare shield. The shield (especially in case of multiple shields) can also be terminated with a lug and fastened with a screw at the clamp plate. Leave the other end of the shield unconnected or ground it indirectly via a few nanofarads high-frequency capacitor eg, 3.3 nF / 630 V. The shield can also be grounded

directly at both ends if they are *in the same ground line* with no significant voltage drop between the end points. Tighten the screws to secure the connection.

3. Connect the conductors to the appropriate detachable terminals of the control unit. See section [Default I/O connection diagram](#), page 92. Use shrink tubing or insulating tape to contain any stray strands.

**Note:** Keep any signal wire pairs twisted as close to the terminals as possible. Twisting the wire with its return wire reduces disturbances caused by inductive coupling.

## Default I/O connection diagram

**Notes:**

[...] denotes default setting with ACS850 Standard Control Program (Factory macro). See *Firmware Manual* for other macros.

\*Total maximum current: 200 mA

The wiring shown is for demonstrative purposes only. Further information of the usage of the connectors and jumpers are given in the text; see also the chapter [Technical data](#).

**Wire sizes and tightening torques:**

**XPOW, XRO1, XRO2, XRO3, XD24:**  
0.5 ... 2.5 mm<sup>2</sup> (24...12 AWG). Torque: 0.5 N·m (5 lbf·in)

**XDI, XDIO, XAI, XAO, XD2D, XSTO:**  
0.5 ... 1.5 mm<sup>2</sup> (28...14 AWG). Torque: 0.3 N·m (3 lbf·in)

**Order of terminal headers and jumpers**

- XPOW (2-pole, 2.5 mm<sup>2</sup>)
- XRO1 (3-pole, 2.5 mm<sup>2</sup>)
- XRO2 (3-pole, 2.5 mm<sup>2</sup>)
- XRO3 (3-pole, 2.5 mm<sup>2</sup>)
- XD24 (4-pole, 2.5 mm<sup>2</sup>)
- DI/DIO grounding selection
- XDI (7-pole, 1.5 mm<sup>2</sup>)
- XDIO (2-pole, 1.5 mm<sup>2</sup>)
- XAI (7-pole, 1.5 mm<sup>2</sup>)
- AI1, AI2
- XAO (4-pole, 1.5 mm<sup>2</sup>)
- T
- XD2D (3-pole, 1.5 mm<sup>2</sup>)
- XSTO (orange) (4-pole, 1.5 mm<sup>2</sup>)

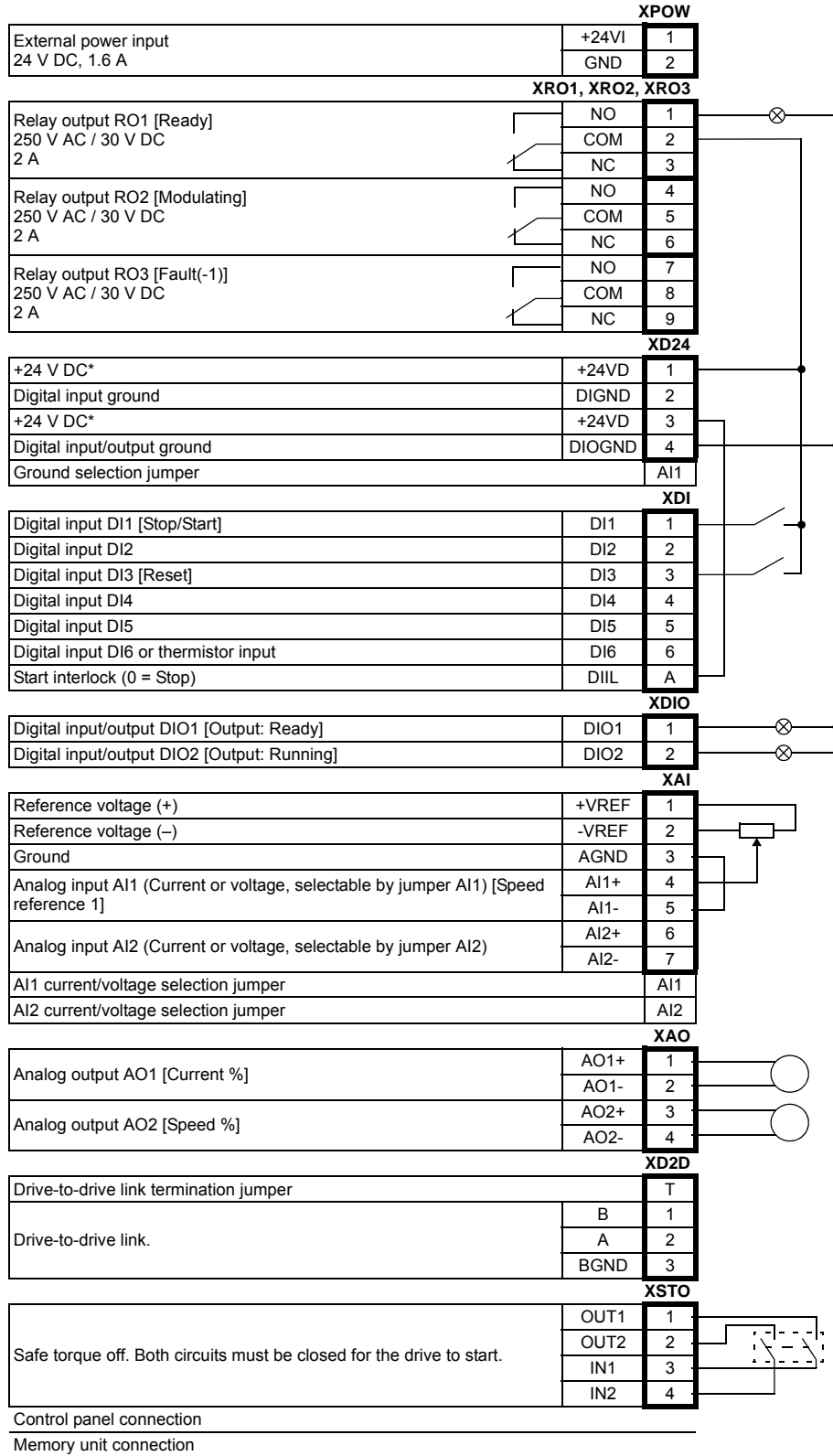

### Jumpers

DI/DIO grounding selector (located between XD24 and XD1) – Determines whether the DIGND (ground for digital inputs DI1...DI5) floats, or if it is connected to DIOGND (ground for DI6, DIO1 and DIO2). See the JCU isolation and grounding diagram on page 121.

If DIGND floats, the common of digital inputs DI1...DI5 should be connected to XD24:2. The common can be either GND or  $V_{CC}$  as DI1...DI5 are of the NPN/PNP type.

DIGND floats

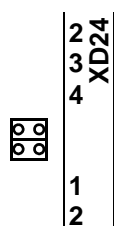

DIGND tied to DIOGND

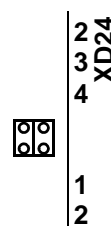

AI1 – Determines whether analog input AI1 is used as a current or voltage input.

Current

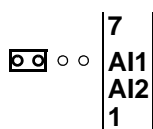

Voltage

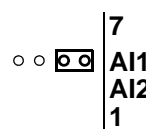

AI2 – Determines whether analog input AI2 is used as a current or voltage input.

Current

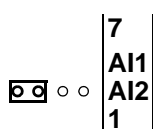

Voltage

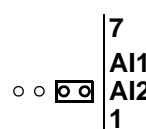

T – Drive-to-drive link termination. Must be set to the ON position when the drive is the last unit on the link.

Termination ON



Termination OFF



**External power supply for the JCU Control Unit (XPOW)**

External +24 V (minimum 1.6 A) power supply for the control unit can be connected to terminal block XPOW. Using an external supply is recommended if

- the application requires fast start after connecting the drive to the main supply
- fieldbus communication is required when the input power supply is disconnected.

**DI6 (XDI:6) as a thermistor input**

1...3 PTC sensors can be connected to this input for motor temperature measurement.

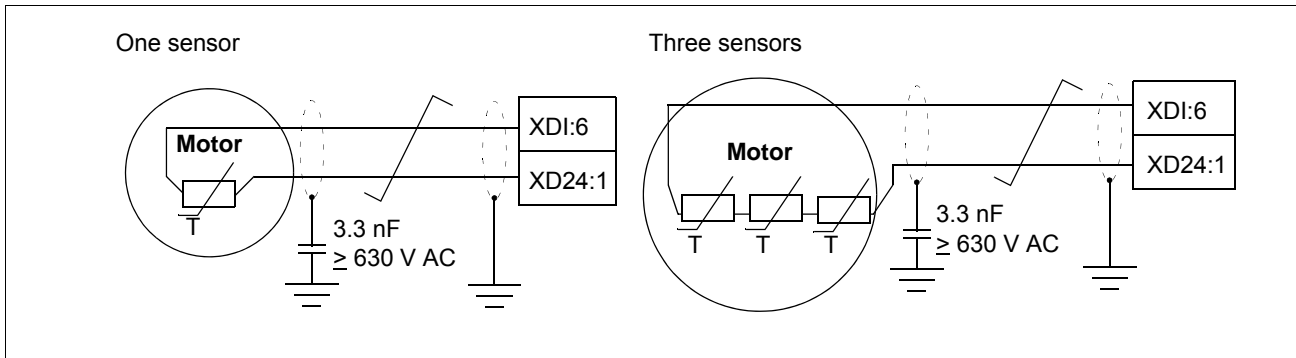

**Notes:**

- Do not connect both ends of the cable shields directly to ground. If a capacitor cannot be used at one end, leave that end of the shield unconnected.
- The connection of temperature sensors involves parameter adjustment. See the *Firmware manual* of the drive.
- PTC (as well as KTY84) sensors can alternatively be connected to a FEN-xx encoder interface. See the *User's manual* of the interface for wiring information.
- Pt100 sensors are not to be connected to the thermistor input. Instead, an analog input and an analog current output (located either on the JCU or on an I/O extension module) are used as shown below. The analog input must be set to voltage.

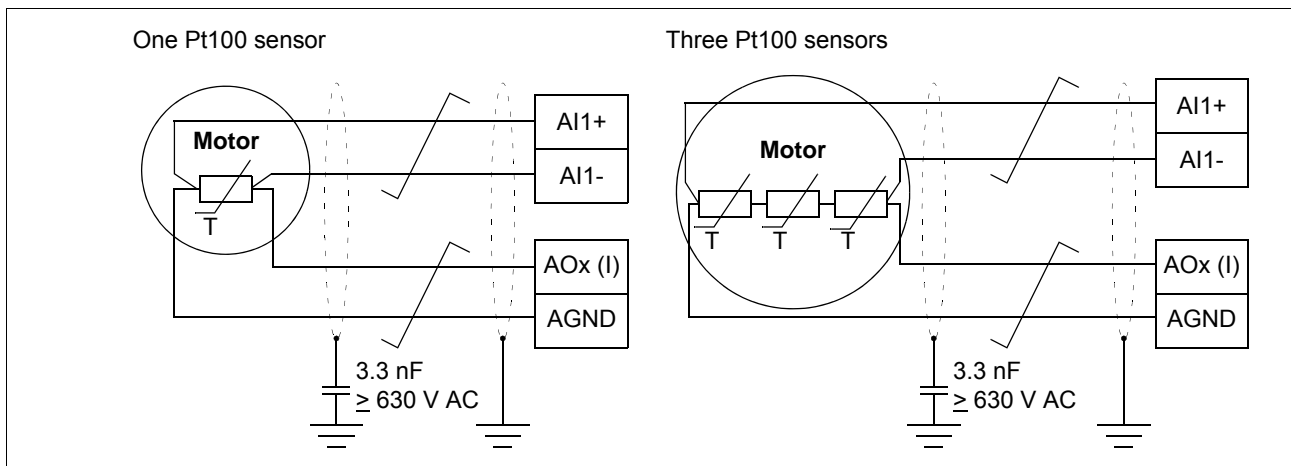



**WARNING!** As the inputs pictured above are not insulated according to IEC 60664, the connection of the motor temperature sensor requires double or reinforced insulation between motor live parts and the sensor. If the assembly does not fulfil the requirement,

- the I/O board terminals must be protected against contact and must not be connected to other equipment

or

- the temperature sensor must be isolated from the I/O terminals.

*Drive-to-drive link (XD2D)*

The drive-to-drive link is a daisy-chained RS-485 transmission line that allows basic master/follower communication with one master drive and multiple followers.

Termination activation jumper T (see section *Jumpers* above) next to this terminal block must be set to the ON position on the drives at the ends of the drive-to-drive link. On intermediate drives, the jumper must be set to the OFF position.

Shielded twisted-pair cable (~100 ohm, for example PROFIBUS-compatible cable) must be used for the wiring. For best immunity, high quality cable is recommended. The cable should be kept as short as possible; the maximum length of the link is 50 meters (164 ft). Unnecessary loops and running the cable near power cables (such as motor cables) must be avoided. The cable shields must be grounded to the control cable clamp plate on the drive as shown on page 90.

The following diagram shows the wiring of the drive-to-drive link.

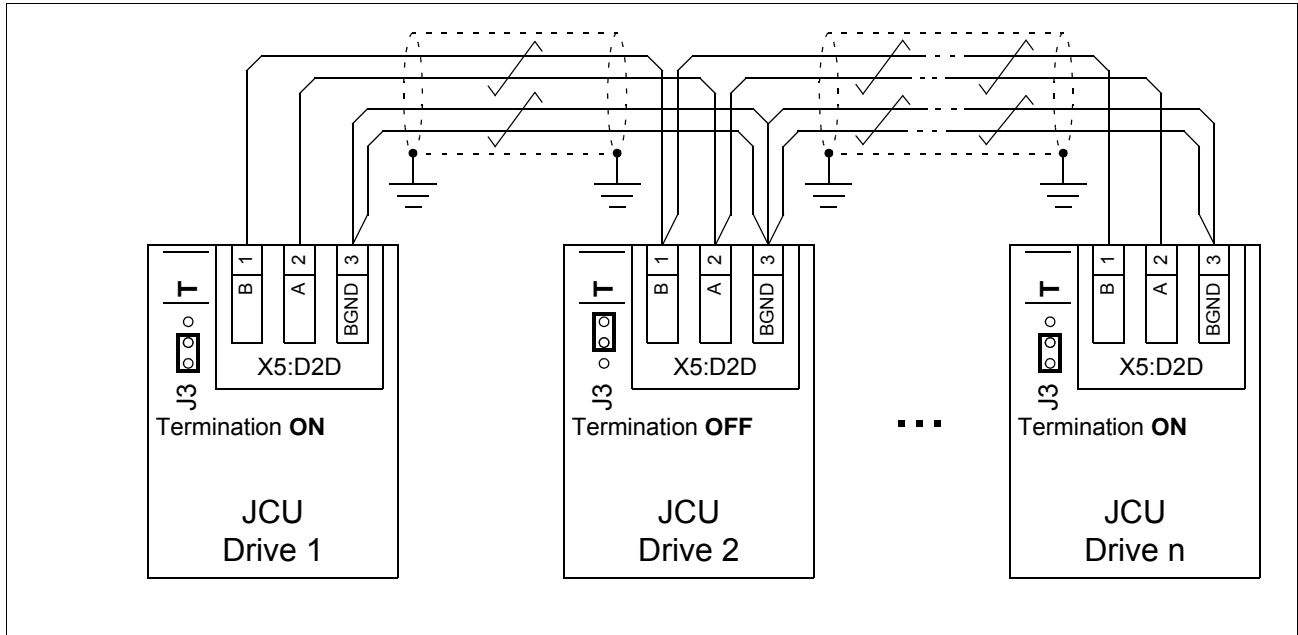

### Safe torque off (XSTO)

For the drive to start, both connections (OUT1 to IN1, and OUT2 to IN2) must be closed. By default, the terminal block has jumpers to close the circuit. Remove the jumpers before connecting an external Safe torque off circuitry to the drive. See page 61.

## Control cable connection procedure of units with internal control unit (option +P905)

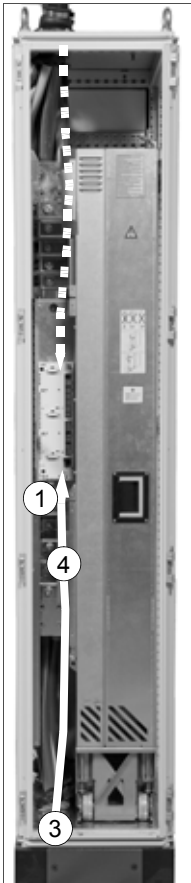

1. Fasten the clamp plate to the control unit with two screws from front, see [Fastening the control cable clamp plate](#) on page 85.
2. Fasten the optional modules if not fastened already.
3. Lead the control cables inside the drive cabinet.
4. Route the control cables along the control cable cable duct from bottom or top to the control unit.
5. Ground the outer control cable shields 360 degrees at the cabinet lead-through plate (recommendation).
6. Ground the control cables at the clamp plate as described in bullet 2 under [Connecting the control cables to the terminals of the control unit](#) on page 92.
7. Connect the conductors to the appropriate detachable terminals of the control unit (see page 92). Use shrink tubing or insulating tape to contain any stray strands. Tighten the screws to secure the connection.
 

**Note:** Keep any signal wire pairs twisted as close to the terminals as possible. Twisting the wire with its return wire reduces disturbances caused by inductive coupling.

## Connecting a PC

Connect the PC to the drive control unit as follows:.

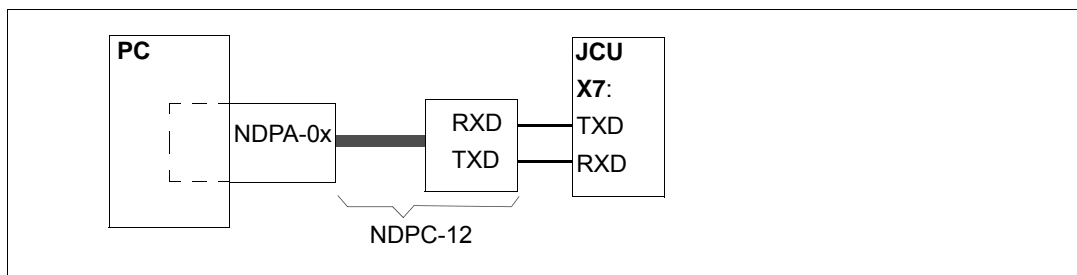



# Installation checklist

---

## What this chapter contains

This chapter contains a list for checking the mechanical and electrical installation of the drive.

## Installation checklist

Go through the checklist below together with another person.



**WARNING!** Follow the safety instructions, page 12. Ignoring the instructions can cause physical injury or death, or damage to the equipment

---

<input checked="" type="checkbox"/>	<b>Check that ...</b>
<b>Cabinet construction</b>	
<input type="checkbox"/>	The drive module is fastened properly to the cabinet. (See chapters <i>Planning the cabinet installation</i> and <i>Installation</i> .)
<input type="checkbox"/>	Mechanical joints are tightened and not broken.
<input type="checkbox"/>	Parts are clean and painted surfaces not scratched. The cabinet frame and parts which are in metal to metal contact with the frame (for example seams, component fixing points on assembly plates, back of control unit mounting plate) are <b>not</b> finished with non-conducting paint or material.
<input type="checkbox"/>	Degree of protection (IPxx)
<b>Drive option modules and other components</b>	
<input type="checkbox"/>	Type and number of option modules and other equipment is correct. Option modules and other equipment are not damaged.
<input type="checkbox"/>	Option modules and terminals are labelled correctly.
<input type="checkbox"/>	The placement of option modules and other equipment inside the cabinet and on the cabinet door is correct.
<input type="checkbox"/>	The mounting of option modules and other equipment is correct.
<b>Internal cabling of the cabinet assembly</b>	
<input type="checkbox"/>	Main circuit: <ul style="list-style-type: none"> <li>• AC supply input cabling is ok.</li> <li>• AC output cabling is ok.</li> <li>• Supply for brake resistor (if used) is ok.</li> </ul>
<input type="checkbox"/>	Cable types, cross-sections, colours and optional markings are correct.
<input type="checkbox"/>	Cabling is not susceptible to interference. Check the twisting of cables and cable routes.

<input checked="" type="checkbox"/>	<b>Check that ...</b>
<input type="checkbox"/>	<p>Connection of cables to devices, terminal blocks and drive module circuit boards:</p> <ul style="list-style-type: none"> <li>• Cables are connected to terminals tight enough by pulling the cable.</li> <li>• Cable termination on terminals chaining is done correctly.</li> <li>• Bare conductors are not too far outside the terminal causing an insufficient clearance or loss of shielding against contact.</li> <li>• JCU Control Unit is wired properly to the drive module.</li> <li>• Control panel cable is connected properly.</li> </ul>
<input type="checkbox"/>	Cables are not lying against sharp edges or bare live parts. Bending radius of fiber optic cables at least 3.5 cm (1.38 in.).
<input type="checkbox"/>	The type, markings, insulation plates and cross connections of terminal blocks are correct.
<b>Grounding and protection</b>	
<input type="checkbox"/>	The grounding colours, cross-section and grounding points of modules and other equipment match the circuit diagrams. No long routes for pigtails.
<input type="checkbox"/>	Connections of PE cables and busbars are tight enough. Pull the cable to test that it does not loosen. No long routes for pigtails.
<input type="checkbox"/>	Doors equipped with electrical equipment are grounded. No long grounding routes. From EMC standpoint best result is achieved with a flat copper braid.
<input type="checkbox"/>	Fans that can be touched are shrouded.
<input type="checkbox"/>	Live parts inside the doors are protected against direct contact to at least IP2x.
<b>Labels</b>	
<input type="checkbox"/>	The type designation labels and warning and instruction stickers are made according to the local regulations and placed correctly.
<b>Switches and doors</b>	
<input type="checkbox"/>	Mechanical switches, main disconnecting switch and cabinet doors function properly.
<b>Installation of the cabinet</b>	
<input type="checkbox"/>	The drive cabinet has been fixed to floor and also from top to the wall or roof.
<input type="checkbox"/>	The ambient operating conditions meet the specifications given in chapter <i>Technical data</i> .
<input type="checkbox"/>	The cooling air will flow freely in and out of the drive cabinet, and air recirculation inside the cabinet will not be possible (air baffle plates are on place).
<input type="checkbox"/>	<u>If the drive has been stored over one year:</u> The electrolytic DC capacitors in the DC link of the drive have been reformed. See page <a href="#">114</a> .
<input type="checkbox"/>	There is an adequately sized protective ground conductor between the drive and the switchboard.
<input type="checkbox"/>	There is an adequately sized protective ground conductor between the motor and the drive.
<input type="checkbox"/>	All protective ground conductors have been connected to the appropriate terminals and the terminals have been tightened. (Pull the conductors to check.)
<input type="checkbox"/>	The enclosures of the equipment in the cabinet have proper galvanic connection to the cabinet protective earth (ground) busbar; The connection surfaces at the fastening points are bare (unpainted) and the connections are tight, or separate grounding conductors have been installed.

<input checked="" type="checkbox"/>	<b>Check that ...</b>
<input type="checkbox"/>	The supply voltage matches the nominal input voltage of the drive. Check the type designation label.
<input type="checkbox"/>	The input power cable has been connected to the appropriate terminals, the phase order is right, and the terminals have been tightened. (Pull the conductors to check.)
<input type="checkbox"/>	Appropriate AC fuses and main disconnect have been installed.
<input type="checkbox"/>	The motor cable has been connected to the appropriate terminals, the phase order is right, and the terminals have been tightened. (Pull the conductors to check.)
<input type="checkbox"/>	The brake resistor (if present) has been connected to the appropriate terminals, and the terminals have been tightened. (Pull the conductors to check.)
<input type="checkbox"/>	The motor cable (and brake resistor cable, if present) has been routed away from other cables.
<input type="checkbox"/>	The brake resistor cable has been routed away from other cables.
<input type="checkbox"/>	No power factor compensation capacitors have been connected to the motor cable.
<input type="checkbox"/>	The control cables (if any) have been connected to the appropriate terminals, and the terminals have been tightened. (Pull the conductors to check.)
<input type="checkbox"/>	<u>If a drive bypass connection will be used:</u> The direct-on-line contactor of the motor and the drive output contactor are either mechanically or electrically interlocked, ie, cannot be closed simultaneously.
<input type="checkbox"/>	There are no tools, foreign objects or dust from drilling inside the drive.
<input type="checkbox"/>	All shrouds and cover of the motor connection box are in place. Cabinet doors have been closed.
<input type="checkbox"/>	The motor and the driven equipment are ready for start.



# Start-up

---

## What this chapter contains

This chapter refers to the start-up instructions of the cabinet-installed drive.

## Start-up procedure

1. Ensure that the installation of the drive has been checked according to the checklist in chapter [Installation checklist](#), and that the motor and driven equipment are ready for start.
2. Perform the start-up tasks instructed by the cabinet-installer of the drive module.
3. Switch the power on and set-up the drive control program according to the start-up instructions given in the drive *Firmware Manual*.



# Fault tracing

---

## What this chapter contains

This chapter describes the fault tracing possibilities of the drive.

## LEDs

This table describes LEDs of the drive module.

Where	LED	When the LED is lit
JINT board	V204 (green)	+5 V voltage of the board is OK.
	V309 (red)	Not in use.
	V310 (green)	IGBT control signal transmission to the gate driver control boards is enabled.
BFPS board	V79 (green)	+5 V voltage of the board is OK.

## Warning and fault messages

See the *Firmware Manual* for the descriptions, causes and remedies of the control program warning and fault messages.



# Maintenance

---

## What this chapter contains

This chapter contains preventive maintenance instructions of the drive module.

## Applicability

The drive module replacement described in this chapter applies to the Rittal TS 8 example installation of chapter [Installation](#). The other maintenance instructions are general.

## Maintenance intervals

If installed in an appropriate environment, the drive requires very little maintenance. This table lists the routine maintenance intervals recommended by ABB.

Interval	Maintenance	Instruction
Every year	Checking main cooling fan and circuit board cooling fan, tightness of terminals, dustiness, corrosion, temperature and quality of supply voltage.	Maintenance if needed. See sections <a href="#">Cabinet</a> and <a href="#">Heatsink</a> on page 109.
Every year when stored	Capacitor reforming	See <a href="#">Reforming the capacitors</a> .
Every 3 years	Checking the condition of fiber optic cables	See the fault logger. If PPCC LINK faults have recurred, change the fiber optic cables.
Every 3 years	Circuit board compartment cooling fan	See <a href="#">Fans</a> .
<b>Every 9 years.</b> <b>Every 6 years</b> if ambient temperature in continuous operation is over 40 °C (104 °F).	Main cooling fan change	See <a href="#">Fans</a> .
Every 6 years <b>Every 3 years</b> if the ambient temperature is 40 °C (104 °F) or cyclic heavy load or continuous nominal load.	Change of DC circuit electrolytic capacitors and discharging resistors	Contact ABB.
Every 9 years	JINT board and flat cable change, BFPS board and JGDR board change	Contact ABB.

Every 9 years	Control panel battery replacement.	The battery is housed on the rear of the control panel. Replace with a new CR 2032 battery.
---------------	------------------------------------	---

Consult your local ABB Service representative for more details on the maintenance. On the Internet, go to ABB website.

## Cabinet

### Cleaning the interior of the cabinet



**WARNING!** Follow the safety instructions, page [12](#). Ignoring the instructions can cause physical injury or death, or damage to the equipment.



**WARNING!** Use a vacuum cleaner with antistatic hose and nozzle. Using a normal vacuum cleaner creates static discharges which can damage circuit boards.

1. Ensure that the drive is disconnected from the power line and all other precautions described under [Safety in installation and maintenance](#) on page [12](#) have been taken into consideration.
2. When necessary, clean the interior of the cabinet with a soft brush and a vacuum cleaner.

## Heatsink

The module heatsink fins pick up dust from the cooling air. The drive runs into overtemperature warnings and faults if the heatsink is not clean.

### Cleaning the interior of the heatsink



**WARNING!** Follow the safety instructions, page 12. Ignoring the instructions can cause physical injury or death, or damage to the equipment.



**WARNING!** Use a vacuum cleaner with antistatic hose and nozzle. Using a normal vacuum cleaner creates static discharges which can damage circuit boards.

1. Ensure that the drive is disconnected from the power line and all other precautions described under *Safety in installation and maintenance* on page 12 have been taken into consideration.
2. Undo the fastening screws of the handle plate of the drive module.
3. Remove the handle plate.
4. Vacuum the interior of the heatsink from the opening.
5. Blow compressed air upwards from the opening and, at the same time, vacuum from the top of the drive module.



## Fans

The actual lifespan depends on the running time of the fan, ambient temperature and dust concentration. See the *Firmware Manual* for the actual signal which indicates the running time of the cooling fan. For resetting the running time signal after a fan replacement, please contact ABB.

Replacement fans are available from ABB. Do not use other than ABB specified spare parts.

### Replacing the circuit board compartment cooling fan



**WARNING!** Follow the safety instructions, page 12. Ignoring the instructions can cause physical injury or death, or damage to the equipment.

1. Remove the drive module out of the cabinet as described in section [Replacing the drive module](#) on page 112.
2. Undo the fastening screw of the fan enclosure.
3. Unplug the power supply cable of the fan.
4. Remove the fan from the enclosure by undoing the four fastening screws.
5. Install the new fan in reverse order to the above.

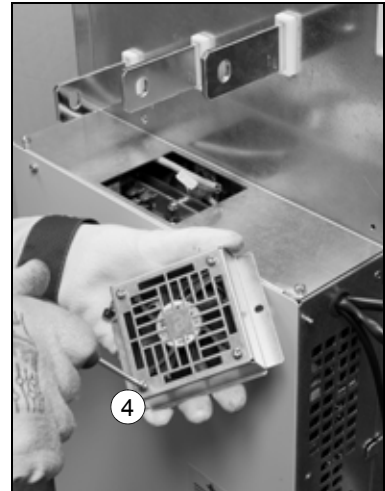

## Replacing the main cooling fans



**WARNING!** Follow the safety instructions, page 12. Ignoring the instructions can cause physical injury or death, or damage to the equipment.

1. Remove the drive module out of the cabinet as described in section *Replacing the drive module* on page 112.
2. Open the support legs of the pedestal.
3. Undo the two screws that fasten the fan assembly plate.
4. Tilt the fan assembly plate down.
5. Disconnect the power supply wires of the fans.
6. Remove the fan assembly from the drive module.
7. Undo the fastening screws of the fan(s) and remove the fan(s) from the assembly plate.
8. Install the new fan(s) in reverse order to the above.

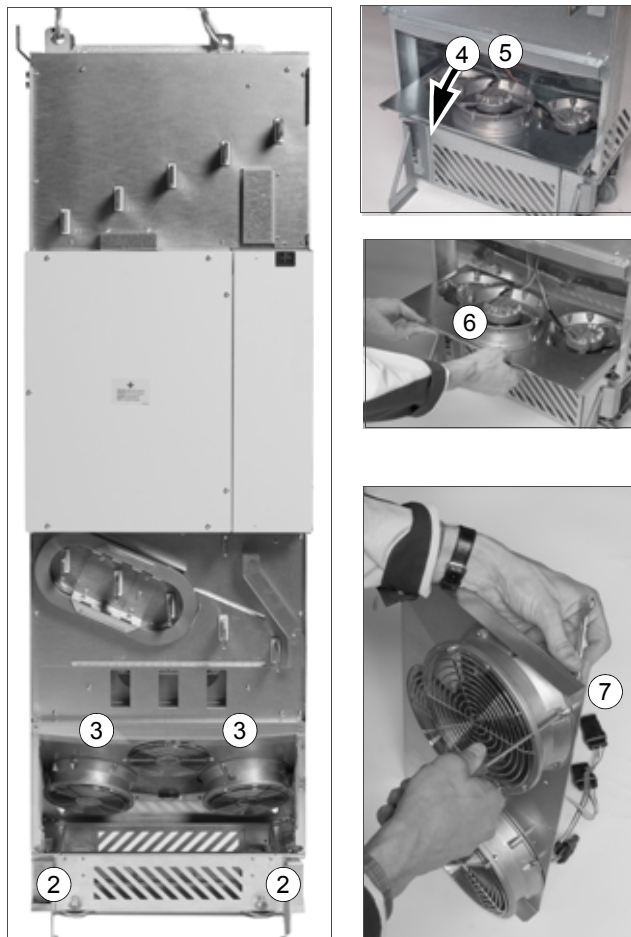

## Replacing the drive module



**WARNING!** Follow the safety instructions, page 12. Ignoring the instructions can cause physical injury or death, or damage to the equipment.

Handle the drive module carefully. Make sure that the module does not fall down when moving it on the floor and during installation and maintenance work: Open the support legs by pressing each leg a little down and turning it aside (1, 2). When ever possible secure the module also with chains.

Do not tilt the drive module (A). It is **heavy** (over 200 kg [440 lb]) and its **center of gravity is high**. The module will overturn from a sideways tilt of 5 degrees. Do not leave the module unattended on a sloping floor.

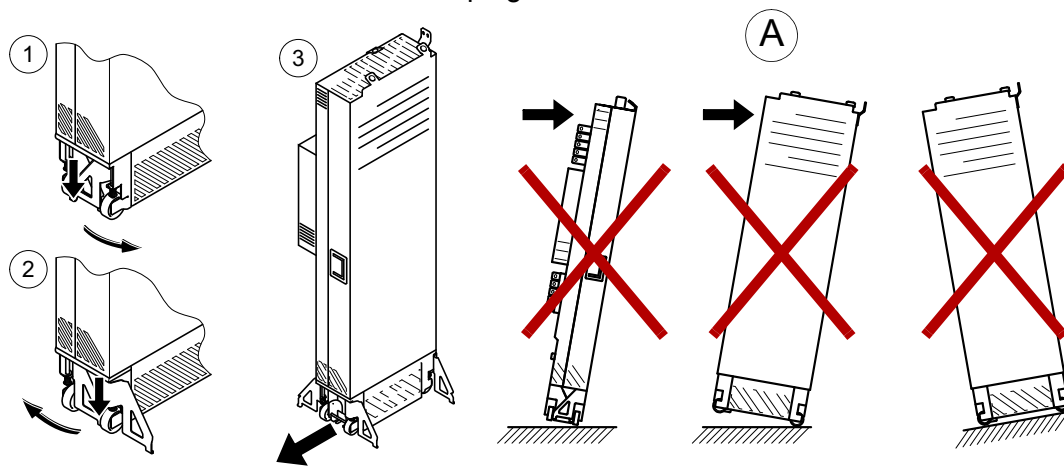

1. Ensure that the drive is disconnected from the power line and all other precautions described under *Safety in installation and maintenance* on page 12 have been taken into consideration.
2. Remove the left-hand side upper and lower front covers of the drive module by undoing the fastening screws. M4×8 combi screws, 2 N·m.
3. Disconnect the drive module busbars from the input cabling panel. Combi screw M12, 70 N·m (52 lbf·ft).
4. Disconnect the drive module busbars from the output cabling panel. Combi screw M12, 70 N·m (52 lbf·ft).
5. Undo the screws that fasten the drive module to the cabinet at the top and behind the front support legs.
6. Fasten the extraction ramp to the cabinet base with two screws.
7. Disconnect the power supply cable and the fibre optic cables from the external control unit and coil them on the top of the drive module. If you have an internal control unit (+P905), detach the control unit from the drive module by undoing the fastening screws below the optional modules and turn the control unit and the cables aside. (Alternatively remove the clamp plate, and disconnect the cables from the control unit.)

- 8. Pull the drive module carefully out of the cabinet preferably with help from another person.
- 9. Install the new module in reverse order to the above.

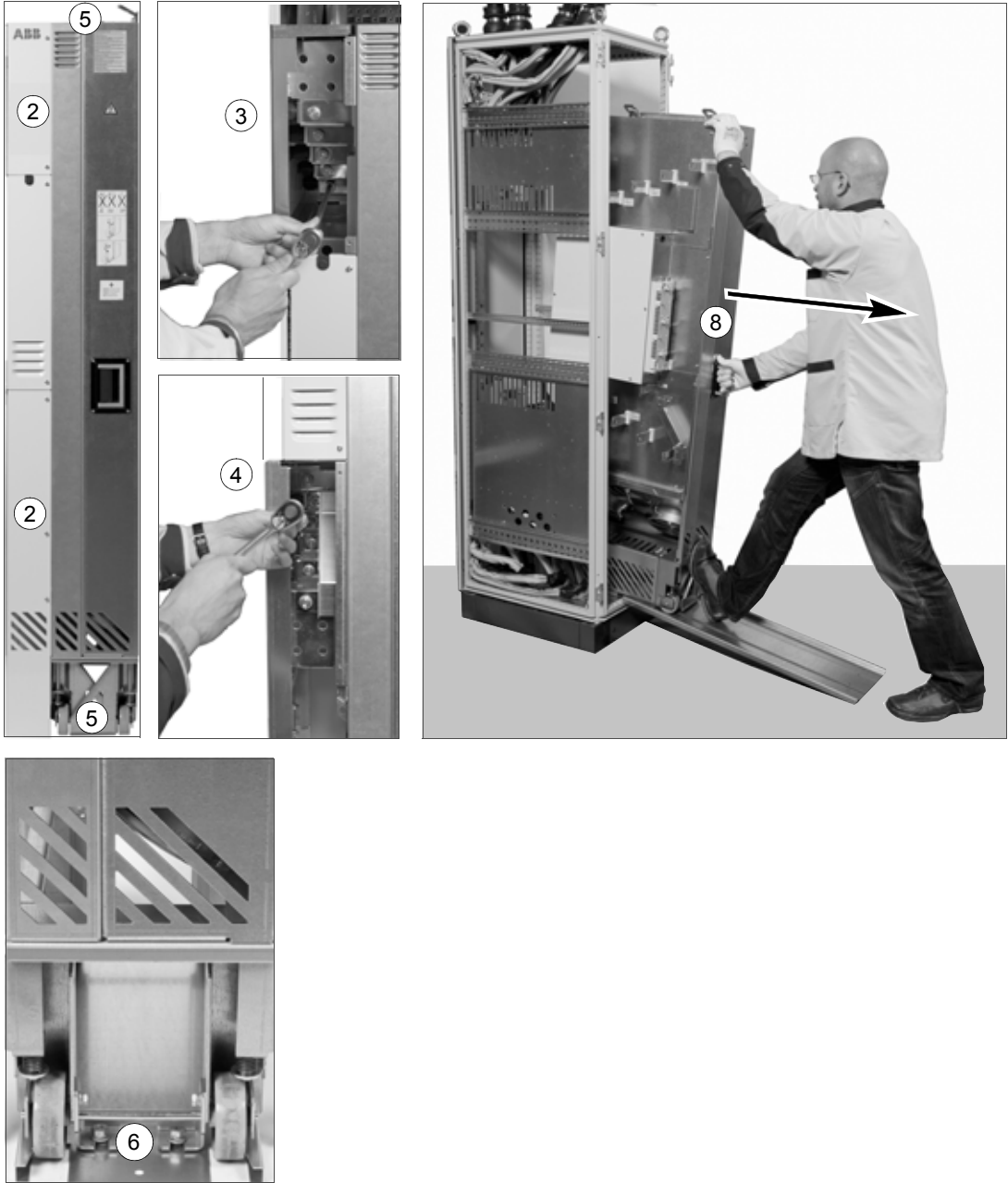

## Capacitors

The drive intermediate circuit employs several electrolytic capacitors. Their lifespan depends on the operating time of the drive, loading and ambient temperature. The lifespan of the capacitor can be prolonged by lowering the ambient temperature.

It is not possible to predict a capacitor failure. The capacitor failure is usually followed by damage to the unit and an input cable fuse failure, or a fault trip. Contact ABB if a capacitor failure is suspected. Replacements are available from ABB. Do not use other than ABB specified spare parts.

### Reforming the capacitors

The capacitors must be reformed if the drive module has been stored for a year or more. See page [31](#) for information on finding out the manufacturing date. For the reforming instructions, see *Converter modules with electrolytic DC capacitors in the DC link, capacitor reforming instructions* (3BFE64059629 [English]).

## Memory unit

When a drive module is replaced, the parameter settings can be retained by transferring the memory unit from the defective drive module to the new module. The memory unit is located in the JCU Control Unit, see page [29](#).



**WARNING!** Do not remove or insert a memory unit when the drive module is powered.

---

After power-up, the drive will scan the memory unit. If a different application program or different parameter settings are detected, they are copied to the drive. This may take several minutes.

# Technical data

## What this chapter contains

This chapter contains the technical specifications of the drive, for example, the ratings, sizes and technical requirements, provisions for fulfilling the requirements for CE and other markings.

## Ratings

The ratings of the drive modules with 400 V, 460 V and 500 V (50 Hz and 60 Hz) supply are given below.

Drive type ACS850-04...	Frame size	Input rating	Output ratings									
			Nominal use				Light-overload use			Heavy-duty use		
			$I_{1N}$	$I_{max}$	$I_{2N}$	$P_N$		$I_{Ld}$	$P_{Ld}$		$I_{Hd}$	$P_{Hd}$
A	A	A	kW	hp	A	kW	hp	A	kW	hp		
$U_N = 400\text{ V}$												
-710A-5	G2	690	850	710	400	-	700	400	-	566	315	-
-807A-5	G2	790	1020	807	450	-	785	450	-	625	355	-
-875A-5	G2	860	1100	875	500	-	850	480	-	680	400	-
$U_N = 500\text{ V}$												
-710A-5	G2	690	850	630	450	-	640	450	-	550	400	-
-807A-5	G2	790	1020	700	500	-	685	500	-	600	430	-
-875A-5	G2	860	1100	780	560	-	720	520	-	650	450	-

PDM 00581898

$I_{1N}$	Nominal input current (rms) at 40 °C (104 °F)
$I_{max}$	Maximum output current. Available for 10 seconds at start, otherwise as long as allowed by drive temperature.
$I_{2N}$	Continuous rms output current. No overload capability at at 40 °C (104 °F)
$P_N$	Typical motor power in no-overload use.
$I_{Ld}$	Continuous rms output current. 10% overload is allowed for 1 minute every 5 minutes.
$P_{Ld}$	Typical motor power for light-overload use.
$I_{Hd}$	Continuous rms output current. 50% overload is allowed for 1 minute every 5 minutes.
$P_{Hd}$	Typical motor power for heavy-duty use.
<b>Note:</b> To achieve the rated motor power given in the table, the rated current of the drive must be higher than or equal to the rated motor current.	
The DriveSize dimensioning tool available from ABB is recommended for selecting the drive, motor and gear combination for the required motion profile.	

## Derating

The continuous output currents stated above must be derated if any of the following conditions apply:

- ambient temperature exceeds +40 °C (+104°F)
- drive is installed higher than 1000 m above sea level.

**Note:** The final derating factor is a multiplication of all applicable derating factors.

*Ambient temperature derating*

In the temperature range +40...55 °C (+104...131 °F), the rated output current is derated by 1% for every added 1 °C (1.8 °F) as follows:

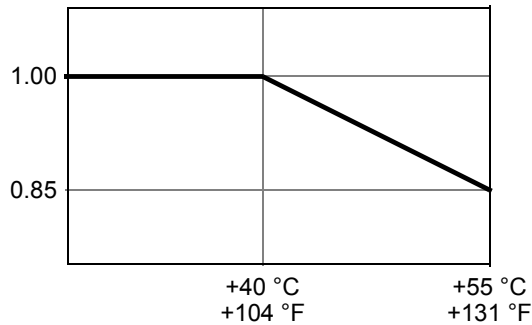
*Altitude derating*

At altitudes from 1000 to 4000 m (3300 to 13123 ft) above sea level, the derating is 1% for every 100 m (328 ft). For a more accurate derating, use the DriveSize PC tool.

**Fuses (IEC)**

<b>Ultrarapid (aR) fuses</b>							
Drive type ACS800- 04...	Input current  A	Fuse					
		A	A <sup>2</sup> s	V	Manufacturer	Type DIN 43620 	Size
-710A-5	690	1600	4150000	690	Bussmann	170M8557D	DIN3
-807A-5	790	1600	4150000	690	Bussmann	170M8557D	DIN3
-875A-5	860	1600	4150000	690	Bussmann	170M8557D	DIN3

**Note 1:** See also [Implementing thermal overload and short-circuit protection](#) on page 59.

**Note 2:** In multicable installations, install only one fuse per phase (not one fuse per conductor).

**Note 3:** Larger fuses than the recommended ones must not be used.

**Note 4:** Fuses from other manufacturers can be used if they meet the ratings and the melting curve of the fuse does not exceed the melting curve of the fuse mentioned in the table.

PDM 00581898

## Dimensions, weights and free space requirements

Drive type ACS850-04	H1 mm	H2	W1 mm	W2 mm	D1 mm	D2 mm	Weight 1 kg	Weight 2 kg
-710A-5	1662	1710	305	329	508	518	200	227
-807A-5	1662	1710	305	329	508	518	200	227
-875A-5	1662	1710	305	329	508	518	202	229

Drive type ACS850-04	H1 in.	H2	W1 in.	W2 in.	D1 in.	D2 in.	Weight 1 lb	Weight 2 lb
-710A-5	65.44	67.33	12.01	12.96	20.00	20.39	440	500
-807A-5	65.44	67.33	12.01	12.96	20.00	20.39	440	500
-875A-5	65.44	67.33	12.01	12.96	20.00	20.39	445	505

H1	Height of the unit with pedestal. External control unit and control panel.
H2	Height of the unit without pedestal. External control unit and control panel.
W1	Width of the basic unit. External control unit and control panels.
W2:	Width of the unit with optional cabling panels (+H318). External control unit and control panel.
D1	Depth of the basic unit. External control unit and control panel.
D2	Depth of the unit with optional cabling panels (+H318). External control unit and control panel.
Weight 1	Weight of the basic unit with pedestal. The pedestal weighs 8 kg (18 lb).
Weight 2	Weight of the unit with pedestal and optional cabling panels (+H318). The pedestal weighs 8 kg (18 lb). The cabling panels weigh 27 kg (60 lb).

**Note:** The dimensions include the lifting lugs but not the cabinet fastening bracket at the top of the module.

For requirements of free space around the drive module, see page [43](#).

## Losses, cooling data and noise

Drive type ACS850-04...	Frame size	Air flow		Heat dissipation W	Noise dB(A)
		m <sup>3</sup> /h	ft <sup>3</sup> /min		
-710A-5	G2	1200	707	8800	72
-807A-5	G2	1200	707	9900	72
-875A-5	G2	1420	848	10600	71

## Terminal and lead-through data for the power cables

The maximum accepted cable size is 4 × (3 × 240) mm<sup>2</sup> or 4 × (3 × 500 AWG).  
Screw size for connecting busbars to the drive module input and output busbars:  
M12, tightening torque 50...75 N·m.

### Units with optional common mode filter(+E208)

The additional busbars are included in the delivery of units with optional common mode filter (+E208). The output busbars of the drive module can be enhanced with the additional busbars in units without optional cabling panels (no +H381). Then, the maximum accepted cable size is  $4 \times (3 \times 240) \text{ mm}^2$  or  $4 \times (3 \times 500 \text{ AWG})$ . Screw size for connecting busbars to the drive module input and output busbars: M12, tightening torque 50...75 N·m.

### Units with optional cabling panels (+H381)

The maximum accepted cable size is  $4 \times (3 \times 240) \text{ mm}^2$  or  $4 \times (3 \times 500 \text{ AWG})$ . The cabling panels are connected to the drive module busbars with M12 serpress nuts, tightening torque 30 N·m ( 20 lbf·ft).

The input cabling panel is equipped with five cable lead-throughs for cables of diameter from 20 mm to 65 mm.

Input, motor and brake resistor cable terminal sizes and tightening torques are given below.

U1, V1, W1, U2, V2, W2, UDC+, UDC-, R+, R-		Grounding busbar	
Screw	Tightening torque N·m	Screw	Tightening torque N·m
M12	50...75	M10	30...44

U1, V1, W1, U2, V2, W2, UDC+, UDC-, R+, R-		Grounding busbar	
Screw	Tightening torque lbf·ft	Screw	Tightening torque lbf·ft
1/2	37...55	3/8	22...32

Two-hole 1/2 inch diameter cable lugs can be used.

## Terminal data for the control cables

See page [92](#).

## Electrical power network specification

<b>Voltage (<math>U_1</math>)</b>	380...500 VAC 3-phase $\pm 10\%$
<b>Rated conditional short-circuit current (IEC 60439-1)</b>	65 kA when protected by fuses given in the fuse tables
<b>Frequency</b>	48 to 63 Hz, maximum rate of change 17%/s
<b>Imbalance</b>	Max. $\pm 3\%$ of nominal phase to phase input voltage
<b>Fundamental power factor (<math>\cos \phi_1</math>)</b>	0.98 (at nominal load)

## Motor connection data

<b>Motor types</b>	Asynchronous AC induction motors, permanent magnet synchronous motors
<b>Voltage (<math>U_2</math>)</b>	0 to $U_1$ , 3-phase symmetrical, $U_{\max}$ at the field weakening point
<b>Frequency</b>	DTC mode: 0 to $3.2 \cdot f_r$ . Maximum frequency 500 Hz (120 Hz with $du/dt$ or sine filter). Low motor noise mode is recommended with high frequencies (see also <i>Firmware manual</i> ).

$$f_f = \frac{U_N}{U_m} \cdot f_m$$

$f_f$ : frequency at field weakening point;  $U_N$ : electrical power system voltage;  $U_m$ : rated motor voltage;  $f_m$ : rated motor frequency

<b>Frequency resolution</b>	0.01 Hz
<b>Current</b>	See section <a href="#">Ratings</a> .
<b>Field weakening point</b>	0...500 Hz
<b>Switching frequency</b>	3 kHz (typically)
<b>Maximum recommended motor cable length</b>	

DTC control	Scalar control
300 m (984 ft)	300 m (984 ft)

**Note:** Motor cable longer than 100 m (328 ft) is allowed but then the EMC Directive requirements of Category C3 may not be fulfilled.

## Brake resistor connection data

See page [139](#).

## DC connection data

Drive module type	$I_{DC}$ (A)	Capacitance (mF)
ACS850-04-710A-5	909	21
ACS850-04-807A-5	1033	21
ACS850-04-875A-5	1120	21

## Control unit (JCU-11) connection data

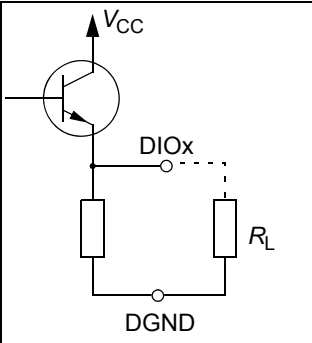
<b>Power supply</b>	24 V ( $\pm 10\%$ ) DC, 1.6 A Supplied from the power unit of the drive, or from an external power supply through connector XPOW (pitch 5 mm, wire size 2.5 mm <sup>2</sup> ).
<b>Relay outputs RO1...RO3 (XRO1 ... XRO3)</b>	Connector pitch 5 mm, wire size 2.5 mm <sup>2</sup> 250 V AC / 30 V DC, 2 A Protected by varistors  <b>Note:</b> The relay outputs of the drive do not fulfill the Protective Extra Low Voltage (PELV) requirements at installation sites above 4000 meters (13123 feet) if used with a voltage greater than 48 V. At installation sites between 2000 meters (6562 feet) and 4000 meters (13123 feet), PELV requirements are not fulfilled if one or two relay outputs are used with a voltage greater than 48 V and the remaining relay output(s) are used with a voltage lower than 48 V.
<b>+24 V output (XD24)</b>	Connector pitch 5 mm, wire size 2.5 mm <sup>2</sup>
<b>Digital inputs DI1...DI6 (XDI:1 ... XDI:6)</b>	Connector pitch 3.5 mm, wire size 1.5 mm <sup>2</sup> 24 V logic levels: "0" < 5 V, "1" > 15 V $R_{in}$ : 2.0 kohm Filtering: 0.25 ms min.  DI6 (XDI:6) can alternatively be used as an input for 1...3 PTC thermistors. <b>Note:</b> The input has no safety insulation (see page 95). $I_{max}$ : 15 mA
<b>Start interlock input DIIL (XDI:A)</b>	Wire size 1.5 mm <sup>2</sup> 24 V logic levels: "0" < 5 V, "1" > 15 V $R_{in}$ : 2.0 kohm
<b>Digital inputs/outputs DIO1 and DIO2 (XDIO:1 and XDIO:2)</b>	Connector pitch 3.5 mm, wire size 1.5 mm <sup>2</sup> <u>As inputs:</u> 24 V logic levels: "0" < 5 V, "1" > 15 V $R_{in}$ : 2.0 kohm Filtering: 0.25 ms min.
Input/output mode selection by parameters.  DIO1 can be configured as a frequency input (0...16 kHz) for 24 V level square wave signal (sinusoidal or other wave form cannot be used). DIO2 can be configured as a 24 V level square wave frequency output. See <i>Firmware Manual</i> , parameter group 12.	<u>As outputs:</u> Total output current limited by auxiliary voltage outputs to 200 mA Output type: Open emitter
	
<b>Reference voltage for analog inputs +VREF and -VREF (XAI:1 and XAI:2)</b>	Connector pitch 3.5 mm, wire size 1.5 mm <sup>2</sup> 10 V $\pm 1\%$ and -10 V $\pm 1\%$ , $R_{load} > 1$ kohm

**Analog inputs AI1 and AI2 (XAI:4 ... XAI:7).**

Current/voltage input mode selection by jumpers. See page 93.

**Analog outputs AO1 and AO2 (XAO)**

**Drive to drive link (XD2D)**

**Safe torque off connection (XSTO)**

**Control panel / PC connection**

**Isolation and grounding diagram**

Connector pitch 3.5 mm, wire size 1.5 mm<sup>2</sup>

Current input: -20...20 mA,  $R_{in}$ : 100 ohm

Voltage input: -10...10 V,  $R_{in}$ : 200 kohm

Differential inputs, common mode  $\pm 20$  V

Sampling interval per channel: 0.25 ms

Filtering: 0.25 ms min.

Resolution: 11 bit + sign bit

Inaccuracy: 1% of full scale range

Connector pitch 3.5 mm, wire size 1.5 mm<sup>2</sup>

0...20 mA,  $R_{load} < 500$  ohm

Frequency range: 0...800 Hz

Resolution: 11 bit + sign bit

Inaccuracy: 2% of full scale range

Connector pitch 3.5 mm, wire size 1.5 mm<sup>2</sup>

Physical layer: RS-485

Termination by jumper

Connector pitch 3.5 mm, wire size 1.5 mm<sup>2</sup>

For the drive to start, both connections (OUT1 to IN1, and OUT2 to IN2) must be closed

Connector: RJ-45

Cable length < 3 m

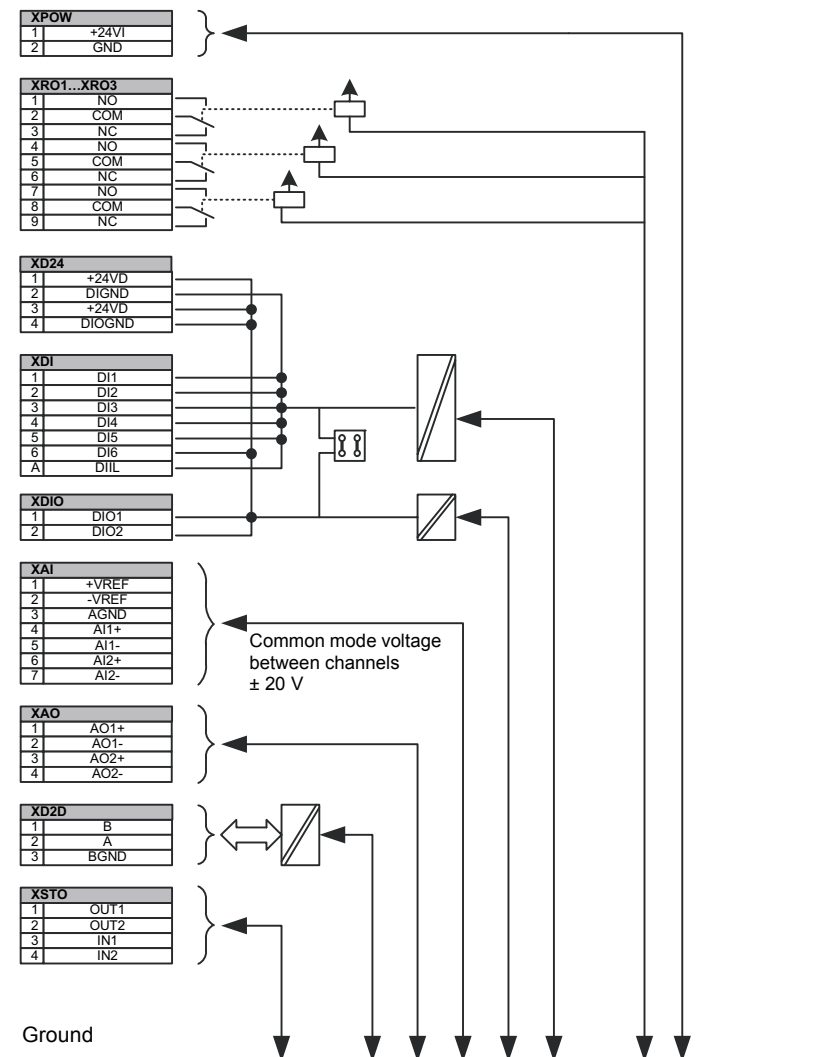

## Efficiency

Approximately 98% at nominal power level

## Degree of protection

Without optional cabling panels IP00 ( (UL type open). IP20 (UL type open) with optional cabling panels (+H381).

## Ambient conditions

Environmental limits for the drive are given below. The drive is to be used in a heated, indoor, controlled environment.

	<b>Operation</b> installed for stationary use	<b>Storage</b> in the protective package	<b>Transportation</b> in the protective package
<b>Installation site altitude</b>	0 to 4000 m (13123 ft) above sea level (above 1000 m [3281 ft]), see section <i>Derating</i> ]	-	-
<b>Air temperature</b>	-15 to +55 °C (5 to 131 °F). No frost allowed. See section <i>Derating</i> .	-40 to +70 °C (-40 to +158 °F)	-40 to +70 °C (-40 to +158 °F)
<b>Relative humidity</b>	5 to 95%	Max. 95%	Max. 95%
	No condensation allowed. Maximum allowed relative humidity is 60% in the presence of corrosive gases.		
<b>Contamination levels</b> (IEC 60721-3-3, IEC 60721-3-2, IEC 60721-3-1)	No conductive dust allowed.		
	<b>Boards with coating:</b> Chemical gases: Class 3C2 Solid particles: Class 3S2	<b>Boards with coating:</b> Chemical gases: Class 1C2 Solid particles: Class 1S3	<b>Boards with coating:</b> Chemical gases: Class 2C2 Solid particles: Class 2S2
<b>Atmospheric pressure</b>	70 to 106 kPa 0.7 to 1.05 atmospheres	70 to 106 kPa 0.7 to 1.05 atmospheres	60 to 106 kPa 0.6 to 1.05 atmospheres
<b>Vibration</b> (IEC 60068-2-6. Test Fc)	Max. 0.1 mm (0.004 in.) (10 to 57 Hz), max. 10 m/s <sup>2</sup> (33 ft/s <sup>2</sup> ) (57 to 150 Hz) sinusoidal	Max. 1 mm (0.04 in.) (5 to 13.2 Hz), max. 7 m/s <sup>2</sup> (23 ft/s <sup>2</sup> ) (13.2 to 100 Hz) sinusoidal	Max. 3.5 mm (0.14 in.) (2 to 9 Hz), max. 15 m/s <sup>2</sup> (49 ft/s <sup>2</sup> ) (9 to 200 Hz) sinusoidal
<b>Shock</b> (IEC 60068-2-29)	Not allowed	Max. 100 m/s <sup>2</sup> (330 ft./s <sup>2</sup> ), 11 ms	Max. 100 m/s <sup>2</sup> (330 ft./s <sup>2</sup> ), 11 ms
<b>Free fall</b>	Not allowed	100 mm (4 in.) for weight over 100 kg (220 lb)	100 mm (4 in.) for weight over 100 kg (220 lb)

## Materials

---

<b>Drive enclosure</b>	<ul style="list-style-type: none"> <li>• PC/ABS 2.5 mm, colour NCS 1502-Y (RAL 9002 / PMS 420 C)</li> <li>• hot-dip zinc coated steel sheet 1.5 to 2.5 mm, thickness of coating 100 micrometers, colour NCS 1502-Y</li> </ul>
<b>Package</b>	Plywood and cardboard, bands PP.
<b>Disposal</b>	<p>The drive contains raw materials that should be recycled to preserve energy and natural resources. The package materials are environmentally compatible and recyclable. All metal parts can be recycled. The plastic parts can either be recycled or burned under controlled circumstances, according to local regulations. Most recyclable parts are marked with recycling marks.</p> <p>If recycling is not feasible, all parts excluding electrolytic capacitors and printed circuit boards can be landfilled. The DC capacitors (C1-1 to C1-x) contain electrolyte and the printed circuit boards contain lead, both of which are classified as hazardous waste within the EU. They must be removed and handled according to local regulations.</p> <p>For further information on environmental aspects and more detailed recycling instructions, please contact your local ABB distributor.</p>

## Applicable standards

---

	The drive complies with the following standards. The compliance with the European Low Voltage Directive is verified according to standards EN 61800-5-1 and EN 60204-1.
<b>EN 61800-5-1:2003</b>	<i>Adjustable speed electrical power drive systems. Part 5-1: Safety requirements – electrical, thermal and energy</i>
<b>EN 60204-1:2006</b>	<i>Safety of machinery. Electrical equipment of machines. Part 1: General requirements.</i> Provisions for compliance: The final assembler of the machine is responsible for installing - emergency-stop device - supply disconnecting device - drive module into a cabinet.
<b>EN 60529:1992 (IEC 60529)</b>	<i>Degrees of protection provided by enclosures (IP code)</i>
<b>IEC 60664-1:2007</b>	<i>Insulation coordination for equipment within low-voltage systems. Part 1: Principles, requirements and tests.</i>
<b>EN 61800-3:2004</b>	<i>Adjustable speed electrical power drive systems. Part 3: EMC requirements and specific test methods</i>
<b>EN 61800-5-2:2007</b>	<i>Adjustable speed electrical power drive systems. Part 5-2: Safety requirements – Functional</i>
<b>UL 508C (2002)</b>	<i>UL Standard for Safety, Power Conversion Equipment, second edition</i>
<b>CSA C22.2 No. 14-05</b>	<i>Industrial control equipment</i>

## CE marking

A CE mark is attached to the drive to verify that the unit follows the provisions of the European Low Voltage and EMC Directives.

### Compliance with the European Low Voltage Directive

The compliance with the European Low Voltage Directive has been verified according to standards EN 61800-5-1 and EN 60204-1.

### Compliance with the European EMC Directive

The EMC Directive defines the requirements for immunity and emissions of electrical equipment used within the European Union. The EMC product standard (EN 61800-3:2004) covers requirements stated for drives. See section [Compliance with the EN 61800-3:2004](#) below.

## Compliance with the European Machinery Directive

The drive complies with the European Union Machinery Directive requirements for an equipment intended to be incorporated into machinery.

## Compliance with the EN 61800-3:2004

### Definitions

EMC stands for **Electromagnetic Compatibility**. It is the ability of electrical/electronic equipment to operate without problems within an electromagnetic environment. Likewise, the equipment must not disturb or interfere with any other product or system within its locality.

*First environment* includes establishments connected to a low-voltage network which supplies buildings used for domestic purposes.

*Second environment* includes establishments connected to a network not supplying domestic premises.

*Drive of category C3*: drive of rated voltage less than 1000 V and intended for use in the second environment and not intended for use in the first environment.

*Drive of category C4*: drive of rated voltage equal to or above 1000 V, or rated current equal to or above 400 A, or intended for use in complex systems in the second environment.

### Category C3

The drive complies with the standard with the following provisions:

1. The motor and control cables are selected as specified in the *Hardware Manual*.
2. The drive is installed according to the instructions given in the *Hardware Manual*.
3. Maximum cable length is 100 metres.

**WARNING!** A drive of category C3 is not intended to be used on a low-voltage public network which supplies domestic premises. Radio frequency interference is expected if the drive is used on such a network.

## Category C4

If the provisions under *Category C3* cannot be met, the requirements of the standard can be met as follows:

1. It is ensured that no excessive emission is propagated to neighbouring low-voltage networks. In some cases, the inherent suppression in transformers and cables is sufficient. If in doubt, the supply transformer with static screening between the primary and secondary windings can be used.

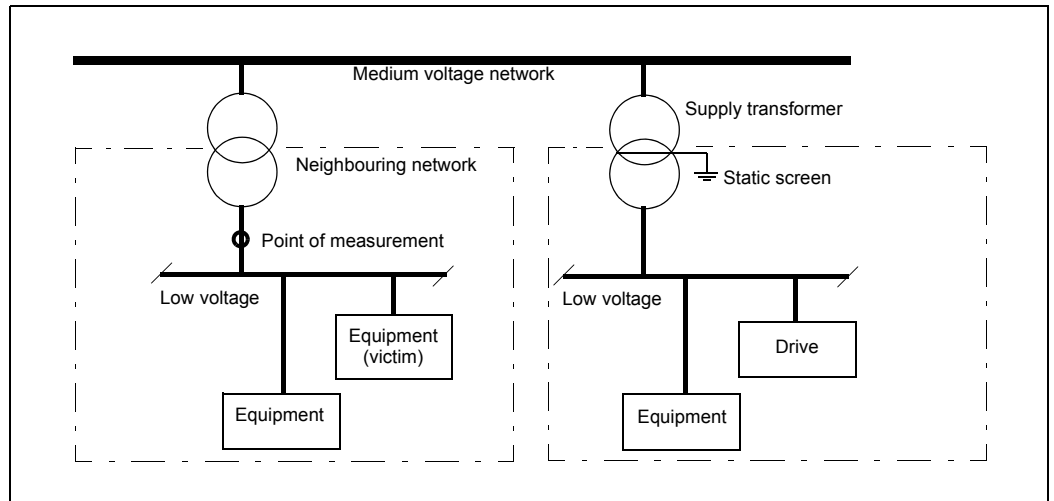

2. An EMC plan for preventing disturbances is drawn up for the installation. A template is available from the local ABB representative.
3. The motor and control cables are selected as specified in the *Hardware Manual*.
4. The drive is installed according to the instructions given in the *Hardware Manual*.

**WARNING!** A drive of category C4 is not intended to be used on a low-voltage public network which supplies domestic premises. Radio frequency interference is expected if the drive is used on such a network.



# Dimension drawings

---

## What this chapter contains

This chapter contains dimension drawings of the drive modules with optional parts for Rittal TS 8 cabinet assembly.

# Drive module dimensions

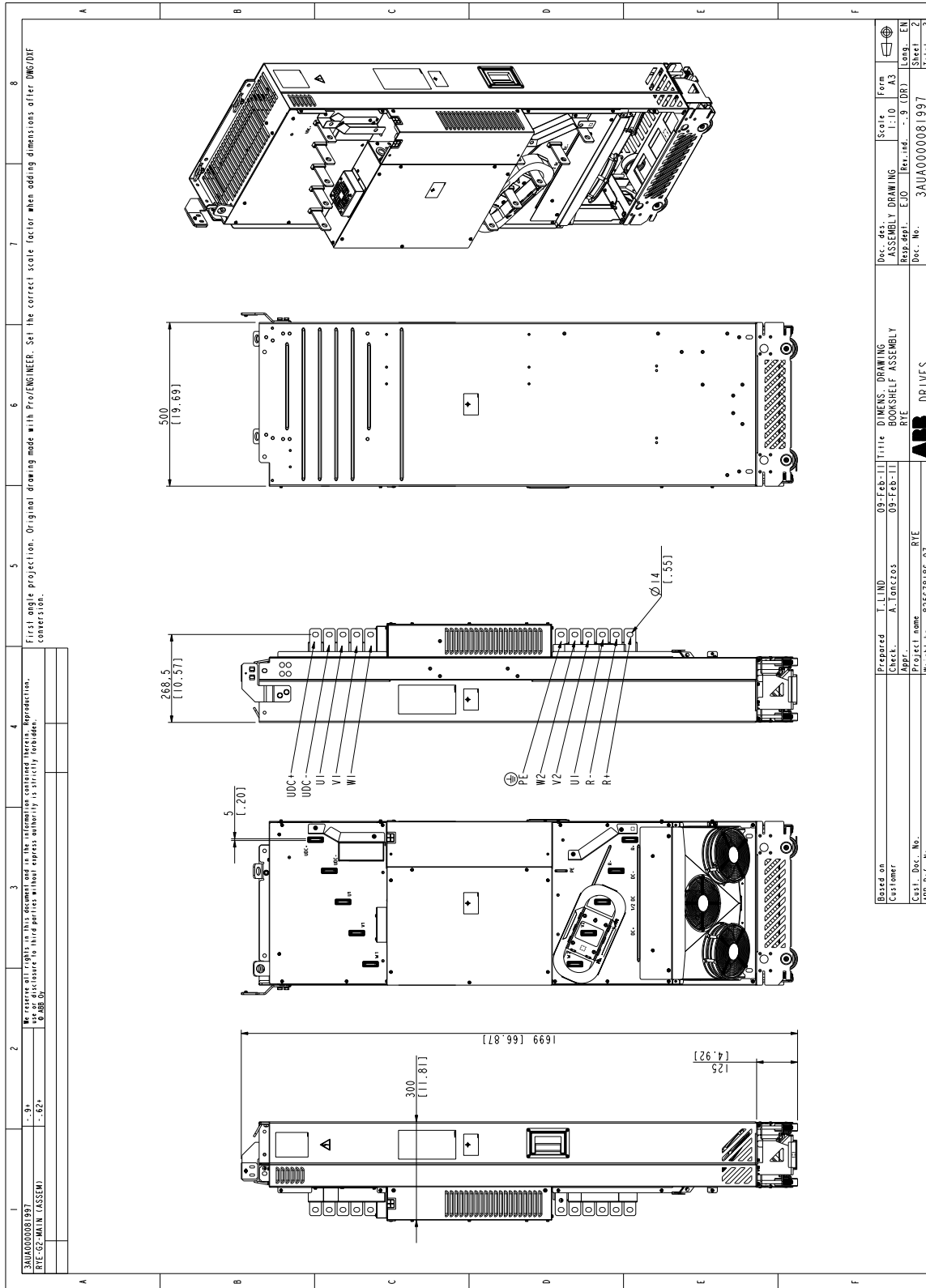

Prepared by	T. Lind	08-Feb-11	08-Feb-11	08-Feb-11	08-Feb-11	08-Feb-11	08-Feb-11	08-Feb-11	08-Feb-11
Customer	A. Toledo								
Check	A. Toledo								
Appr.									
Project name	RYE								
Weight kg	825678.86.07								
ABB Ref. No.									
Doc. desc.	ASSEMBLY DRAWING								
Resp. dept.	EJ0								
Doc. No.	3AUJ0000081997								
Scale	1:10								
Form	A3								
Sheet	2								
Total	3								

# Drive module dimensions with optional cabling panels (+H381)

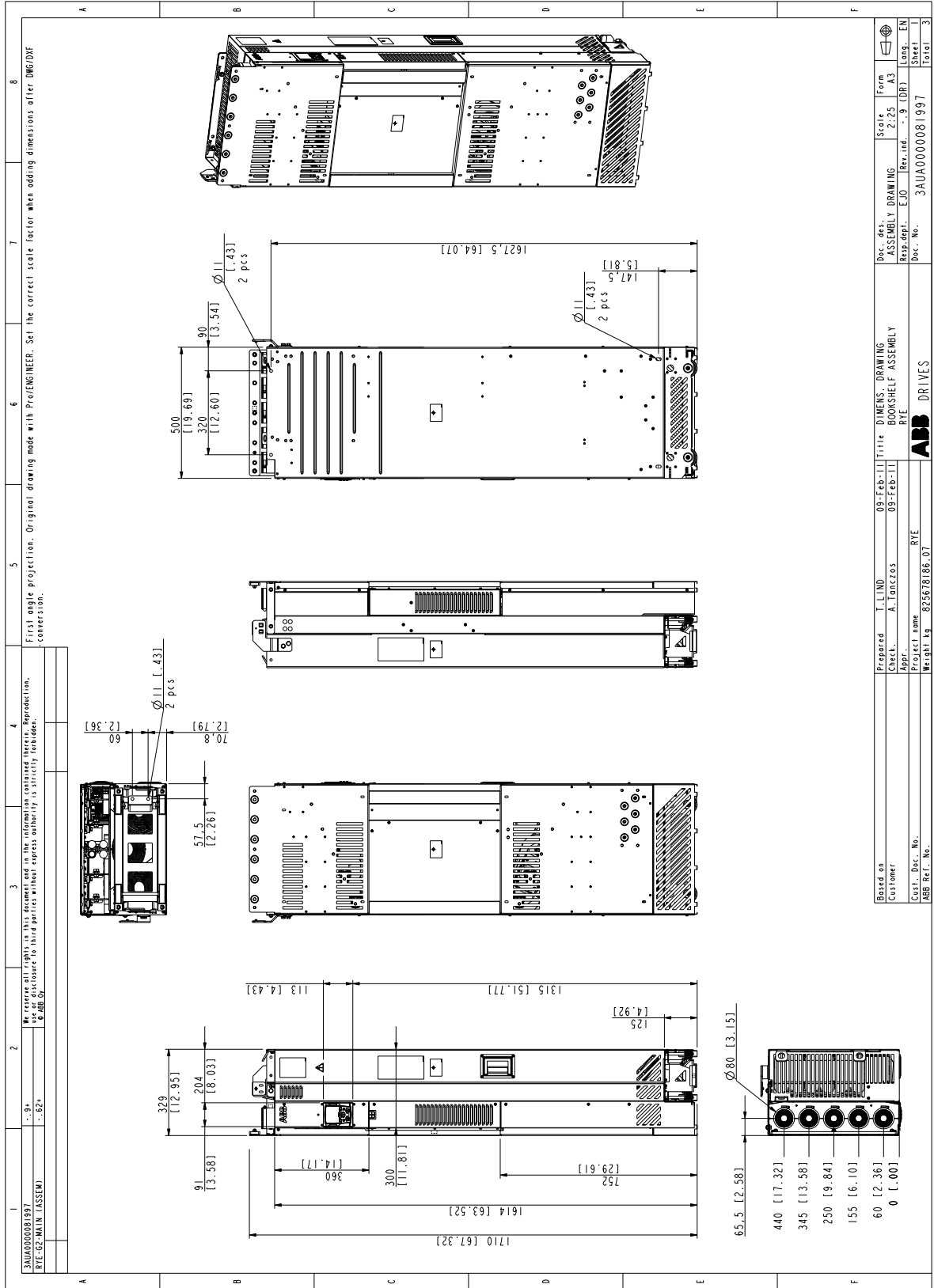

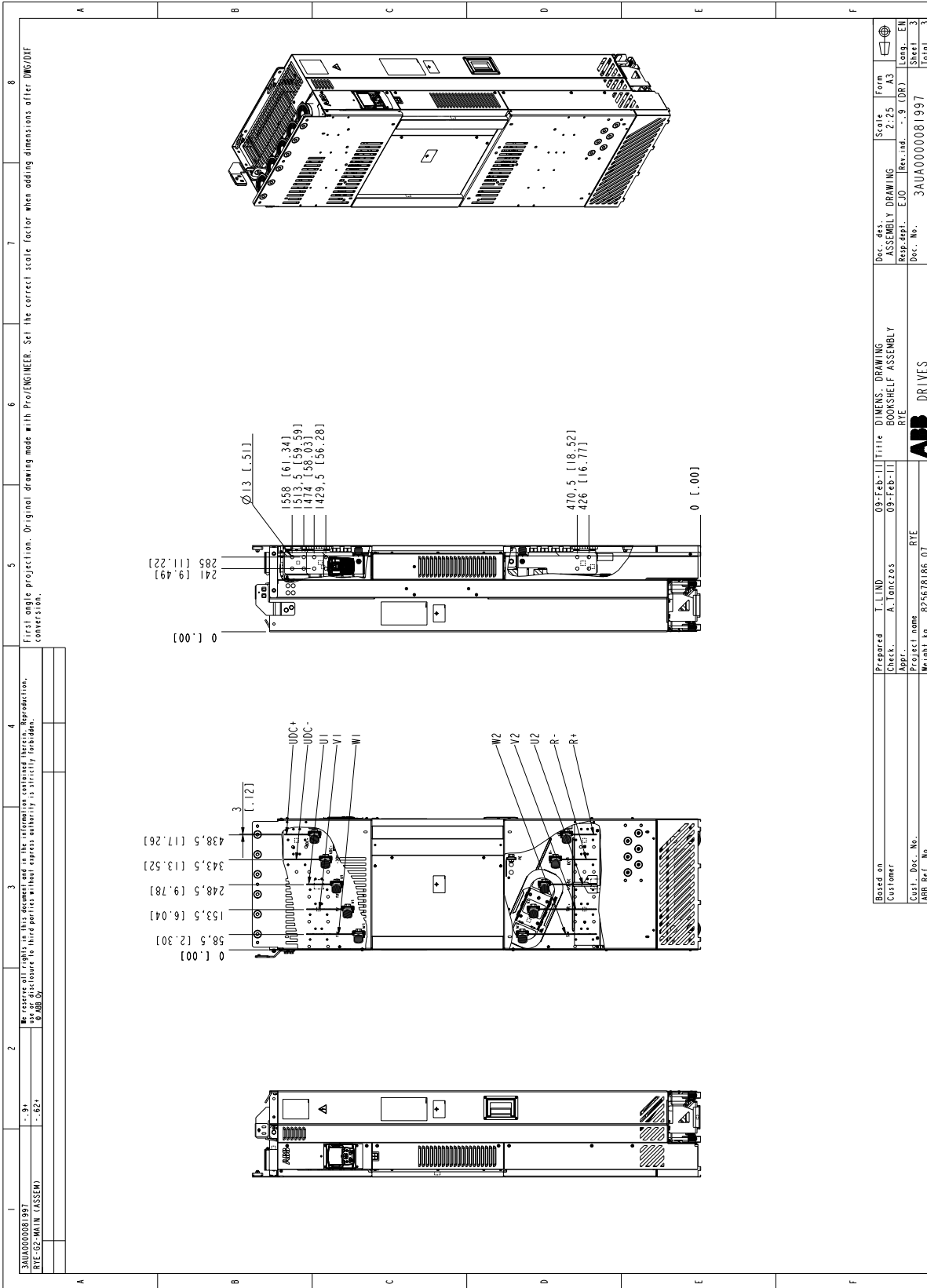

Doc. No.	3AU0000081997	Doc. Title	DRIVES
Rev. No.	3	Rev. No.	3
Scale	2:1	Scale	2:1
Form	AS	Form	AS
ASSEMBLY DRAWING		ASSEMBLY DRAWING	
Prep. by	EJO	Prep. by	EJO
Checked		Checked	
Drawn		Drawn	
Project name	RYE	Project name	RYE
Weight kg	8235618.866.07	Weight kg	8235618.866.07
Customer	A. Tomiczok	Customer	A. Tomiczok
Based on	I. Lind	Based on	I. Lind
Prepared		Prepared	
Title	BOARDSHELF ASSEMBLY	Title	BOARDSHELF ASSEMBLY
DATE	09-FEB-11	DATE	09-FEB-11
DIMENS: DRAWING		DIMENS: DRAWING	

# Cabling panels (option +H381) installed into a Rittal TS 8 cabinet

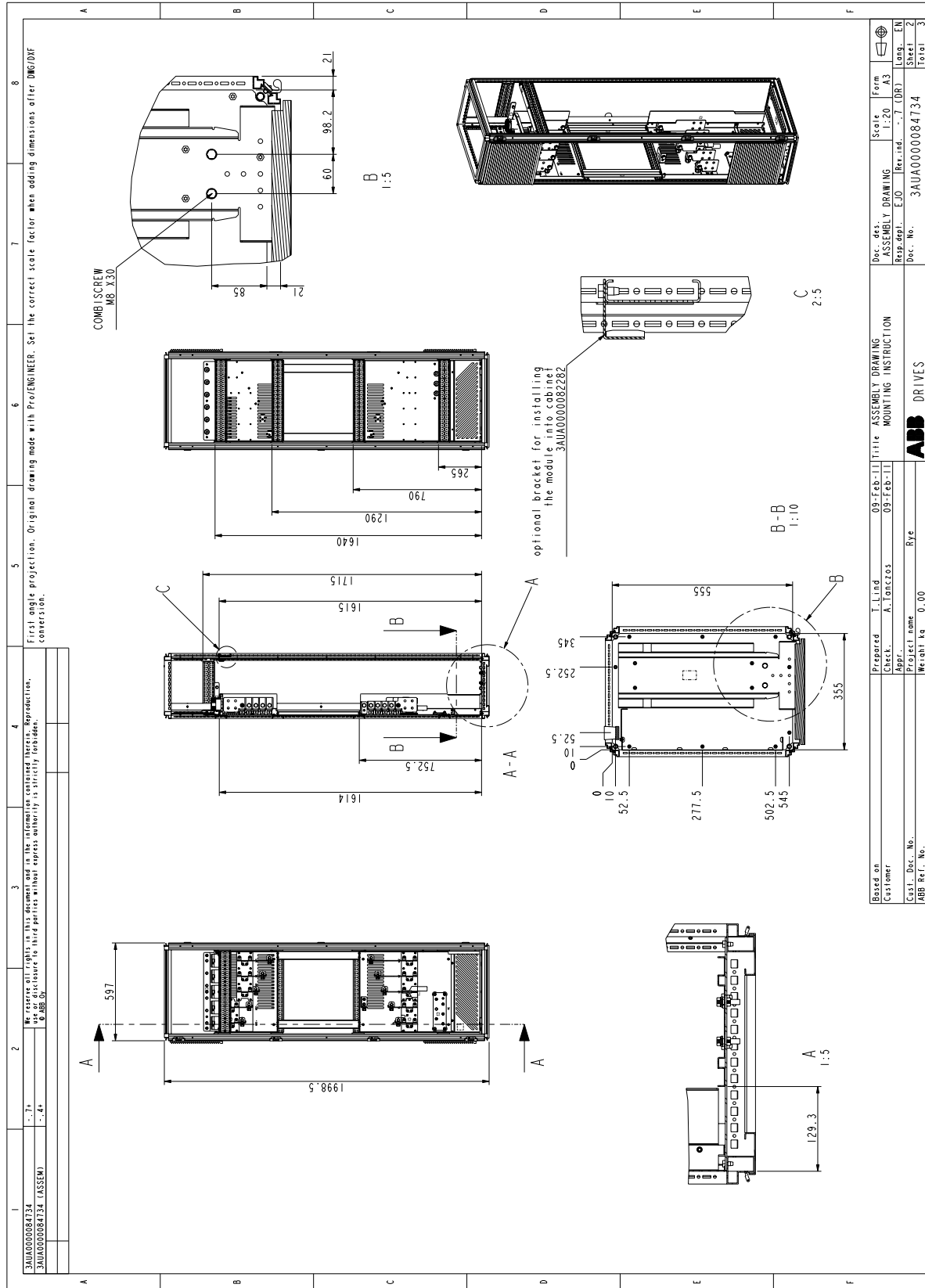



# Example circuit diagrams

---

## What this chapter contains

This chapter shows an example circuit diagram for a cabinet-installed drive module.

## Example circuit diagram

This diagram is an example for the main wiring of a drive cabinet. Note that the diagram includes components which are not included in a basic delivery (\* plus code options, \*\* other options, \*\*\* to be acquired by the customer).

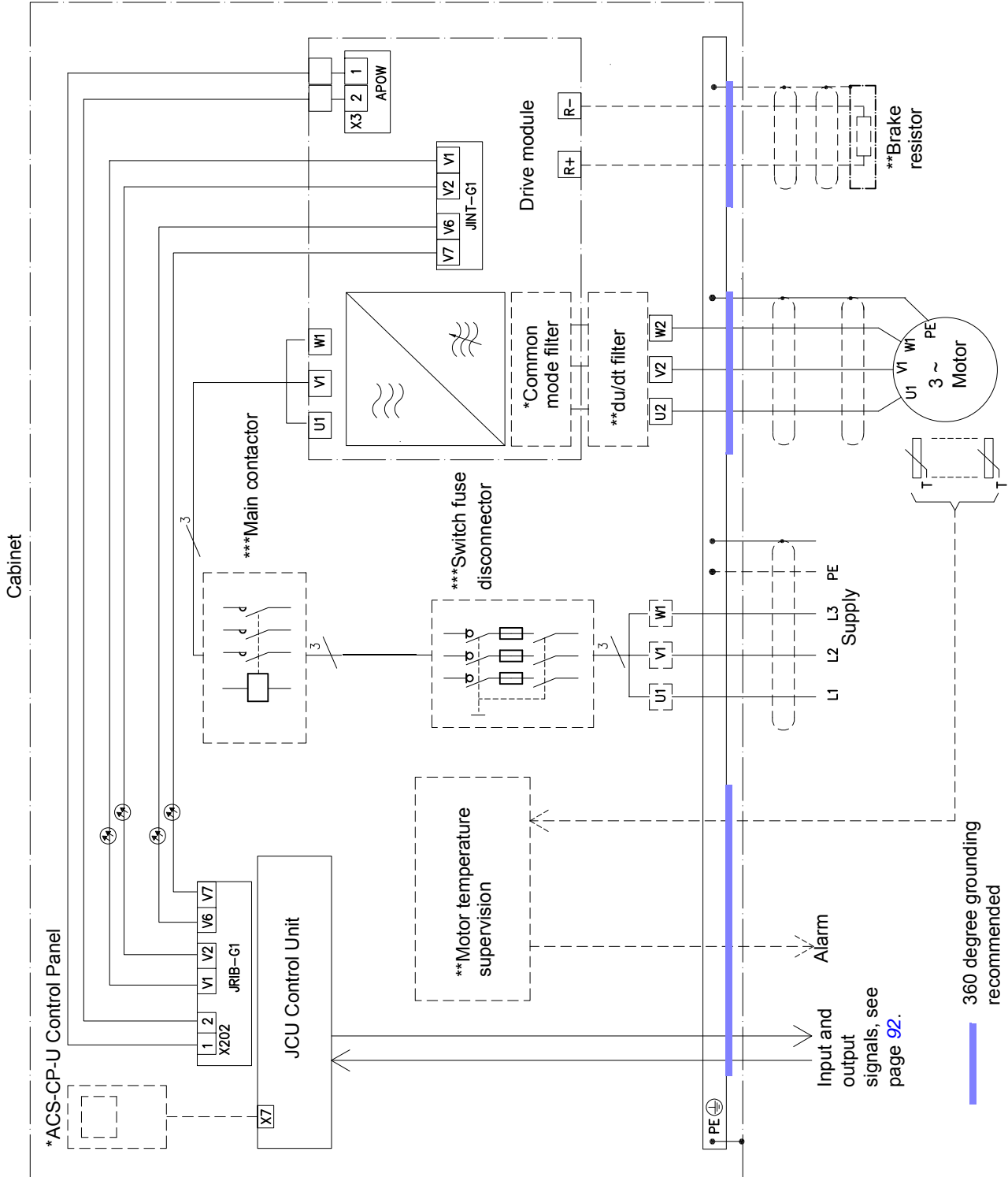

# Resistor braking

---

## What this chapter contains

This chapter describes how to select, protect and wire brake resistors.

## Availability of brake choppers and resistors

Brake choppers are optionally available as built-in units, indicated in the type description by +D150.

Resistors are available as add-on kits.

## When is resistor braking needed

Typically, a drive system is equipped with brake choppers and resistors if:

- high capacity braking is needed and the drive cannot be equipped with a regenerative supply unit
- a backup for the regenerative supply unit is needed.

## Operation principle

The energy generated by the motor during a fast deceleration of the drive typically causes the voltage to rise in the drive module intermediate DC circuit. The chopper connects the brake resistor to the intermediate DC circuit whenever the voltage in the circuit exceeds its maximum limit. Energy consumption by the resistor losses lowers the voltage until the resistor can be disconnected.

## Hardware description

The resistors available from ABB as add-on kits are built in an IP20 metal frame. 4×SAFUR resistors are connected in parallel.

## Planning the braking system

### Selecting the brake circuit components

1. Calculate the maximum power ( $P_{\max}$ ) generated by the motor during braking.

2. Select a suitable drive and brake resistor combination for the application according to the rating table on page 139. Take also account of other factors in the drive selection. The braking power must be greater than or equal to the maximum power generated by the motor during braking:

$$P_{br} \geq P_{max}$$

3. Check the resistor selection. The energy generated by the motor during a 400-second period must not exceed the resistor heat dissipation capacity  $E_R$ .

**Note:** If the  $E_R$  value is not sufficient, it is possible to use a four-resistor assembly in which two standard resistors are connected in parallel, two in series. The  $E_R$  value of the four-resistor assembly is four times the value specified for the standard resistor.

A resistor other than the standard resistor can be used provided that:

- its resistance is not lower than the resistance of the standard resistor



**WARNING!** Never use a brake resistor with a resistance below the value specified for the particular drive / brake chopper / resistor combination. The drive and the chopper are not able to handle the overcurrent caused by the low resistance.

- the resistance does not restrict the braking capacity needed, ie,

$$P_{max} < \frac{U_{DC}^2}{R}$$

where

$P_{max}$	Maximum power generated by the motor during braking
$U_{DC}$	Voltage over the resistor during braking eg, 1.35 · 1.2 · 415 V DC when supply voltage is 380 to 415 VAC 1.35 · 1.2 · 500 V DC when supply voltage is 440 to 500 VAC
$R$	Resistor resistance (ohm)

- the heat dissipation capacity ( $E_R$ ) is sufficient for the application, see step 3 above.

### Placing the brake resistors

All resistors must be installed outside the drive module in a place where they will cool and the maximum allowed cable length (10 m [33 ft]) is not exceeded.

Arrange the cooling of the resistor in a way that:

- no danger of overheating is caused to the resistor or nearby materials
- the temperature of the room the resistor is located in does not exceed the allowed maximum.

Supply the resistor with cooling air/water according to the resistor manufacturer's instructions.



**WARNING!** The materials near the brake resistor must be non-flammable. The surface temperature of the resistor is high. Air flowing from the resistor is of hundreds of degrees Celsius. If the exhaust vents are connected to a ventilation system, ensure that the material withstands high temperatures. Protect the resistor against contact.

## Protecting the system in fault situations

### *Thermal overload protection*

The brake chopper protects itself and the resistor cables against thermal overload when the cables are dimensioned according to the nominal current of the drive. The drive control program includes a resistor and resistor cable thermal protection function which can be tuned by the user. See the *Firmware Manual*.

A main contactor is not required for protecting against resistor overheating when the resistor is dimensioned according to the instructions and the internal brake chopper is in use. The drive will disable power flow through the input bridge if the chopper remains conductive in a fault situation but the charging resistor may fail. **Note:** If an external brake chopper (outside the drive module) is used, a main contactor is always required.

A thermal switch (standard in ABB resistors) is required for safety reasons. The cable must be shielded and not longer than the resistor cable.

Thermal switch  
(standard in ABB resistors)

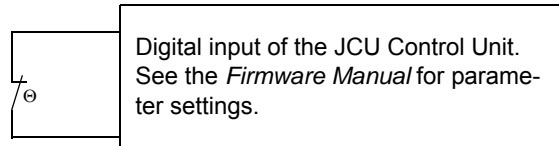

### *Short-circuit protection*

The input fuses will also protect the resistor cable when it is dimensioned according to the input cable.

## Selecting and routing the brake circuit cables

Use the cable type used for drive input cabling (refer to chapter *Technical data*) to ensure that the input fuses will also protect the resistor cable. Alternatively, two-conductor shielded cable with the same cross-sectional area can be used.

### *Minimizing electromagnetic interference*

Follow these rules in order to minimise electromagnetic interference caused by the rapid current changes in the resistor cables:

- Shield the braking power line completely, either by using shielded cable or a metallic enclosure. Unshielded single-core cable can only be used if it is routed inside a cabinet that efficiently suppresses the radiated RFI emissions.
- Install the cables away from other cable routes.

- Avoid long parallel runs with other cables. The minimum parallel cabling separation distance should be 0.3 meters.
- Cross the other cables at right angles.
- Keep the cable as short as possible in order to minimise the EMC emissions and stress on chopper IGBTs. The longer the cable the higher the EMC emissions, inductive load and voltage peaks over the IGBT semiconductors of the brake chopper.

#### *Maximum cable length*

The maximum length of the resistor cable(s) is 10 m (33 ft).

#### **EMC compliance of the complete installation**

**Note:** ABB has not verified that the EMC requirements are fulfilled with external user-defined brake resistors and cabling. The EMC compliance of the complete installation must be considered by the customer.

### **Mechanical installation**

See the resistor manufacturer's instructions.

### **Electrical installation**

See the power cable connection diagram of the drive, page [75](#).

### **Brake circuit commissioning**

- Enable the brake chopper function. Please note that a brake resistor must be connected when the chopper is enabled.
- Switch off the overvoltage control of the drive.
- Adjust any other relevant parameters in group 48.

For more information, see the *Firmware Manual*.



**WARNING!** If the drive is equipped with a brake chopper but the chopper is not enabled by parameter setting, the brake resistor must be disconnected because the protection against resistor overheating is then not in use.

---

## Technical data

### Ratings

The ratings for selecting the brake system components are given below at an ambient temperature of 40 °C (104 °F). **Check that the braking energy transmitted to the specified resistor(s) in 400 seconds does not exceed  $E_R$ .** See page 135.

Drive type	Frame size	Brake resistors			
		Type	$R$ (ohm)	$E_R$ (kJ)	$P_{Rcont}$ (kW)
380...500 V					
ACS850-04-710A-5	G2	4 × SAFUR125F500	1.00	14400	36
ACS850-04-807A-5	G2	4 × SAFUR125F500	1.00	14400	36
ACS850-04-875A-5	G2	4 × SAFUR125F500	1.00	14400	36

3AXD0000600931

$R$  Resistance value for the resistor assembly. **Note:** This is also the minimum allowed resistance for the brake resistor.

$E_R$  Short energy pulse that the resistor assembly withstands every 400 seconds. This energy will heat the resistor element from 40 °C (104 °F) to the maximum allowable temperature.

$P_{Rcont}$  Continuous power (heat) dissipation of the resistor when placed correctly. Energy  $E_R$  dissipates in 400 seconds.

### Brake resistor connection data

Voltage over the resistor during braking is 1.35 · 1.2 · 415 V DC when the supply voltage is 380 to 415 VAC and 1.35 · 1.2 · 500 V DC when the supply voltage is 440 to 500 V AC.

### SAFUR resistors

Degree of protection: IP20. The resistors are not UL listed.

### Maximum resistor cable length

10 m (33 ft)

## Dimensions and weights

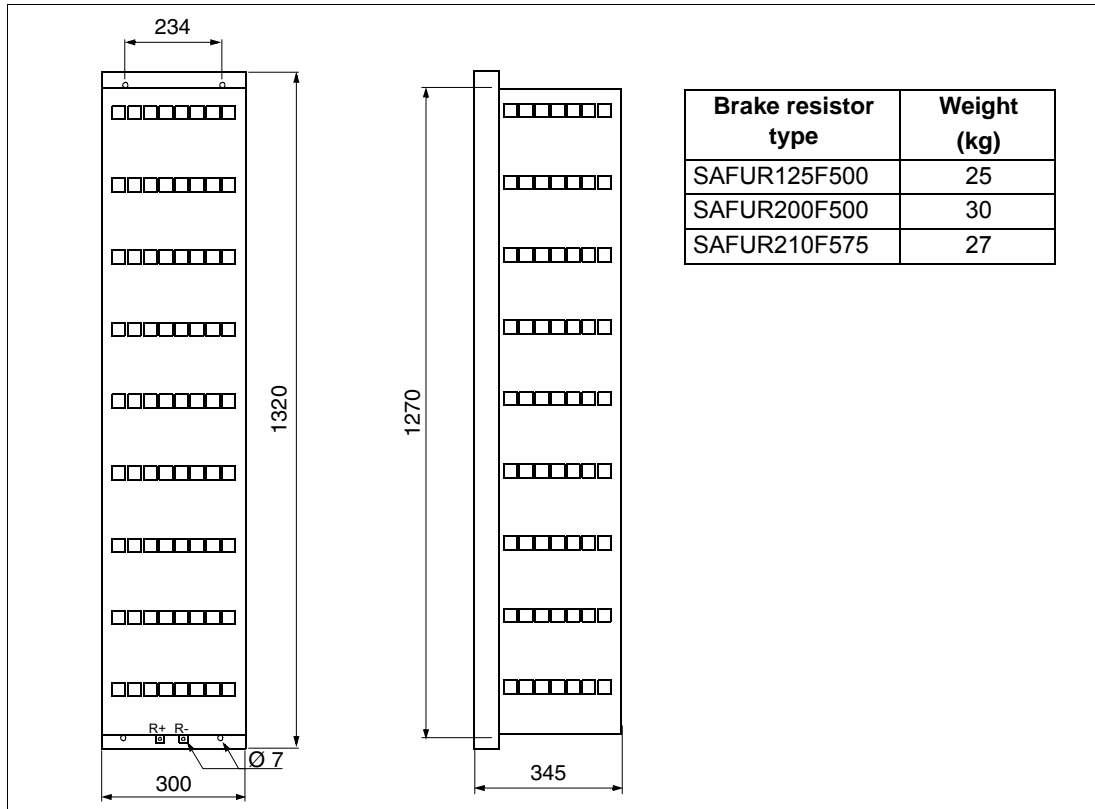

# du/dt filters

---

## What this chapter contains

This chapter describes how to select  $du/dt$  filters for the drive.

## du/dt filters

### When is du/dt filter needed?

See section [Checking the compatibility of the motor and drive](#), page 48.

### Selection table

$du/dt$  filter types for the drive module types are given below.

Drive type	du/dt filter type
ACS850-710A-5	FOCH0610-70
ACS850-807A-5	*
ACS850-875A-5	*

3AXD00000600931

\* Contact ABB for the filter type.

### Description, installation and technical data of the FOCH filters

See *FOCH du/dt Filters Hardware Manual* (3AFE68577519 [English]).



# Further information

---

## Product and service inquiries

Address any inquiries about the product to your local ABB representative, quoting the type designation and serial number of the unit in question. A listing of ABB sales, support and service contacts can be found by navigating to ABB website and selecting *Sales, Support and Service network*.

## Product training

For information on ABB product training, navigate to ABB website and select *Training courses*.

## Providing feedback on ABB Drives manuals

Your comments on our manuals are welcome. Go to ABB website and select *Document Library – Manuals feedback form (LV AC drives)*.

## Document library on the Internet

You can find manuals and other product documents in PDF format on the Internet. Go to ABB website and select *Document Library*. You can browse the library or enter selection criteria, for example a document code, in the search field.